

Isolated Secondary-Side LED Lighting Dimmable Current Controller

General Description

The RT8457A is an isolated secondary LED current controller designed specifically for lighting fixtures such as E27, GU10, T5 and T8 that require power line isolation for safety and reliability, and that require high conversion efficiency as well as high LED current accuracy.

The RT8457A contains 1) a constant current regulating amplifier with 170mV threshold used to program the LED string current with a simple resistor to within 5% LED current accuracy; 2) an over-voltage comparator to protect the output when LED string is open or broken; and 3) an opto-coupler driver to control the primary-side of the transformer to complete the system loop.

Precise dimming is achieved by controlling the LED current at the secondary-side via analog dimming. Applying a voltage greater than 1.1V at the ACTL pin will set the LED current sense threshold between the LED and GND pins at the highest level (around 170mV). The maximum LED current is adjustable by the sense resistor between the LED and GND pins. Lowering the ACTL pin voltage will reduce the LED current sense threshold.

The RT8457A is available in the SOP-8 package.

Features

- Secondary-Side LED Current Regulation
- High Accuracy 170mV LED Current Threshold Control
- 0.5mA Operating Current
- Adjustable LED Current
- Precision Secondary-Side LED Current Dimming
- Precision Analog Dimming at Secondary-Side
- Output Over-Voltage Protection
- SOP-8 Package
- RoHS Compliant and Halogen Free

Applications

- Isolated LED Lighting Fixtures
- E27/GU10/T5/T8 LED Lamp

Marking Information

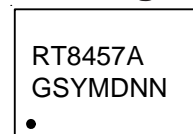

RT8457AGS : Product Number
YMDNN : Date Code

Simplified Application Circuit

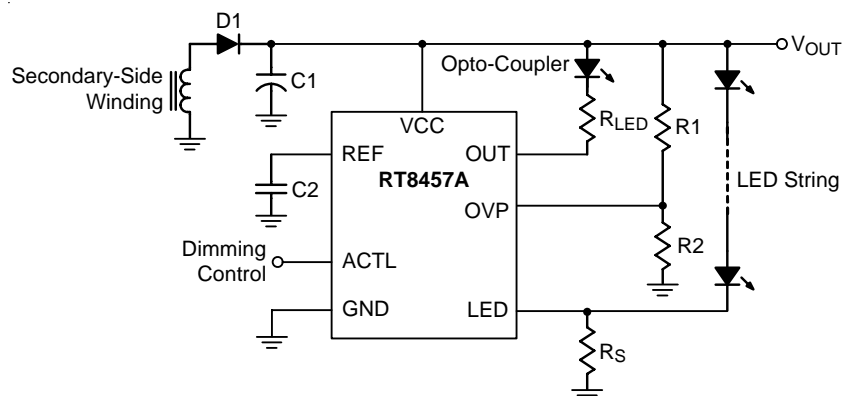

Ordering Information

RT8457A□□

- Package Type
S : SOP-8
- Lead Plating System
G : Green (Halogen Free and Pb Free)

Note :

Richtek products are :

- ▶ RoHS compliant and compatible with the current requirements of IPC/JEDEC J-STD-020.
- ▶ Suitable for use in SnPb or Pb-free soldering processes.

Pin Configurations

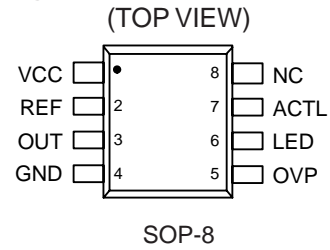

Functional Pin Description

Pin No.	Pin Name	Pin Function
1	VCC	Supply Voltage Input. A 0.1μF bypass capacitor should be connected between VCC and GND.
2	REF	Internal Reference Voltage. A 0.1μF bypass capacitor is required between this pin and GND.
3	OUT	Open-Collector Output. Connect this pin to an opto-coupler with a current limiting resistor.
4	GND	Ground.
5	OVP	Over-Voltage Protection Sense Input with 1V Threshold.
6	LED	LED Current Sense Input. The sense threshold is 170mV when ACTL pin voltage is higher than 1.1V. The threshold can be adjusted by the ACTL pin.
7	ACTL	Analog Dimming Control Input. The LED current sense threshold is at the maximum when the ACTL pin voltage is higher than 1.1V. Must place a 100kΩ from the ACTL pin to GND to avoid the noise interference.
8	NC	No Internal Connection.

Function Block Diagram

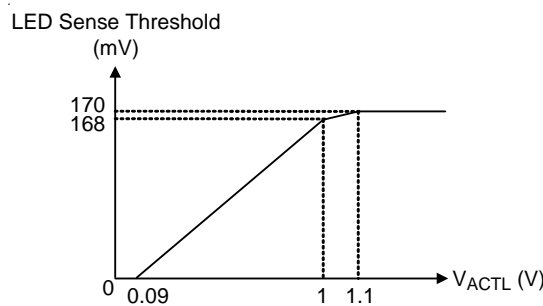
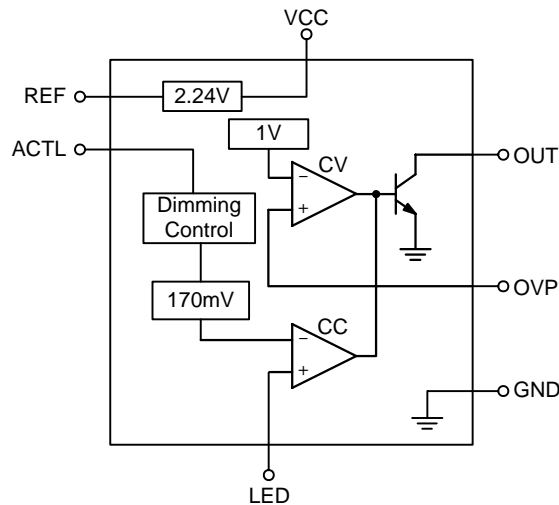

Operation

The available input voltage range is from 2.8V to 38V for the RT8457A. An internal 2.24V reference voltage is generated from VCC input power for internal bias voltage. The RT8457A can be used to monitor the transformer secondary-side output voltage by the CV control loop and regulate the LED string current by the CC control loop at the same time.

The transformer secondary-side output voltage can be monitored by the OVP pin voltage. The sensed OVP pin voltage is compared with the 1V internal reference. When the OVP pin voltage is higher than 1V, the OUT pin will sink more current to allow the external opto-coupler and controller at primary-side to control the output voltage.

The LED string current can be regulated by the LED pin voltage through the current sense resistor connected between the LED and GND pins. The sensed LED pin voltage is compared with the 170mV internal reference. When the LED pin voltage is greater than 170mV, the OUT pin will sink more current to adjust the LED current through an external opto-coupler and controller at primary-side.

The RT8457A is equipped with ACTL pin for LED dimming control function. By adjusting the ACTL pin voltage from 0.09V to 1.1V, the LED current sense threshold for CC loop regulation is linearly changed from 0mV to 170mV.

If ACTL is floating, the LED current sense threshold is 170mV.

Absolute Maximum Ratings (Note 1)

• Supply Input Voltage, VCC	-----	-0.3V to 45V
• ACTL	-----	-0.3V to 8V
• LED	-----	-0.3V to 5V
• OVP	-----	-0.3V to 5V
• OUT	-----	-0.3V to 50V
• Power Dissipation, P _D @ T _A = 25°C		
SOP-8	-----	0.53W
• Package Thermal Resistance (Note 2)		
SOP-8, θ _{JA}	-----	188°C/W
• Lead Temperature (Soldering, 10 sec.)	-----	260°C
• Junction Temperature	-----	150°C
• Storage Temperature Range	-----	-65°C to 150°C
• ESD Susceptibility (Note 3)		
HBM (Human Body Model)	-----	2kV
MM (Machine Model)	-----	200V

Recommended Operating Conditions (Note 4)

• Supply Input Voltage, VCC	-----	2.8V to 38V
• Junction Temperature Range	-----	-40°C to 125°C
• Ambient Temperature Range	-----	-40°C to 85°C

Electrical Characteristics

(V_{CC} = 12V, T_A = 25°C, unless otherwise specified)

Parameter	Symbol	Test Conditions	Min	Typ	Max	Unit
Supply Voltage						
Under-Voltage Lockout Threshold Rising	V _{UVLO}		2.2	2.4	2.6	V
Quiescent Current	I _Q	V _{LED} = 0V, V _{OVP} = 0V	--	500	750	μA
Internal Reference Voltage						
Reference Voltage	V _{REF}		2.16	2.24	2.32	V
OVP & LED Current Regulation						
OVP Voltage	V _{OVP}	I _{REF} = 0A	0.92	1	1.08	V
OVP Input Bias Current	I _{OVP}	V _{OVP} = 0.9V to 1.1V	--	--	100	nA
LED Current Sense Threshold Voltage	V _{LED}	V _{OVP} = 0V, V _{ACTL} = 1V	157.7	166	174.3	mV
		V _{OVP} = 0V, V _{ACTL} = 1.05V	160.6	169	177.5	
		V _{OVP} = 0V, V _{ACTL} = 1.15V	161.5	170	178.5	
		V _{OVP} = 0V, V _{ACTL} = 1.2V	161.5	170	178.5	
LED Dimming						
Analog Dimming ACTL Input Current	I _{ACTL}	0V ≤ V _{ACTL} ≤ 2.2V	--	--	3	μA
LED Current Off Threshold at ACTL	V _{ACTL_OFF}		0.06	0.09	0.12	V

Parameter	Symbol	Test Conditions	Min	Typ	Max	Unit
ACTL Threshold for Max LED Current			1	1.1	1.2	V
OUT Sink Current	I _{OUTH}	V _{OUT} = 1.5V	--	6	--	mA
OUT On-Voltage	V _{OUTL}	I _{OUT} = 2mA	--	--	0.5	V

Note 1. Stresses beyond those listed “Absolute Maximum Ratings” may cause permanent damage to the device. These are stress ratings only, and functional operation of the device at these or any other conditions beyond those indicated in the operational sections of the specifications is not implied. Exposure to absolute maximum rating conditions may affect device reliability.

Note 2. θ_{JA} is measured at $T_A = 25^\circ\text{C}$ on a high effective thermal conductivity four-layer test board per JEDEC 51-7.

Note 3. Devices are ESD sensitive. Handling precaution is recommended.

Note 4. The device is not guaranteed to function outside its operating conditions.

Typical Application Circuit

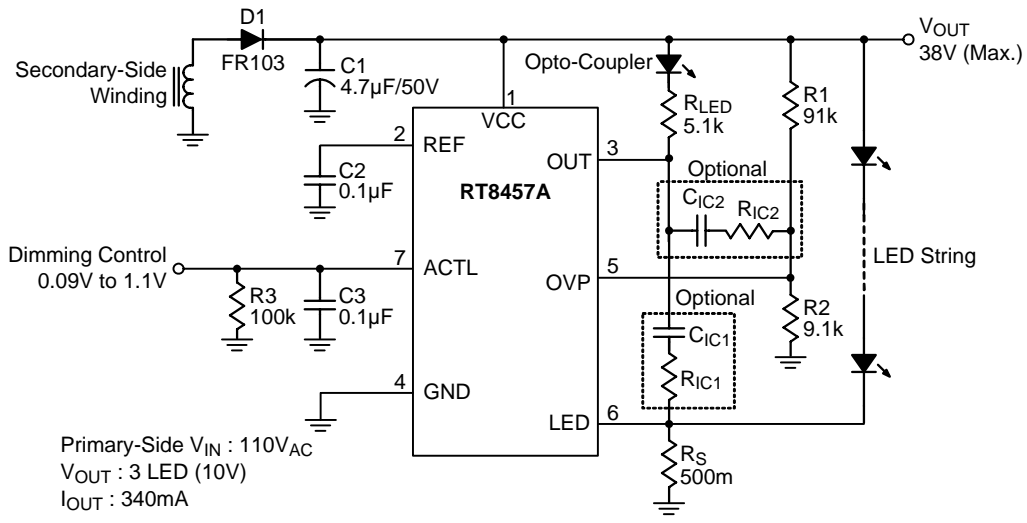

Typical Operating Characteristics

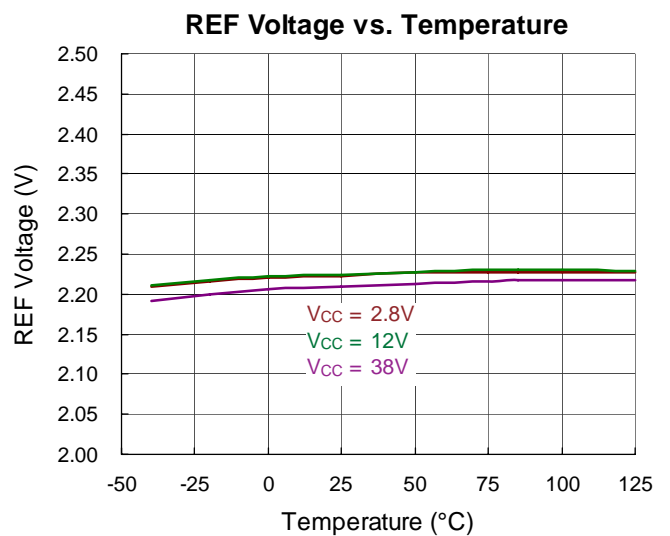
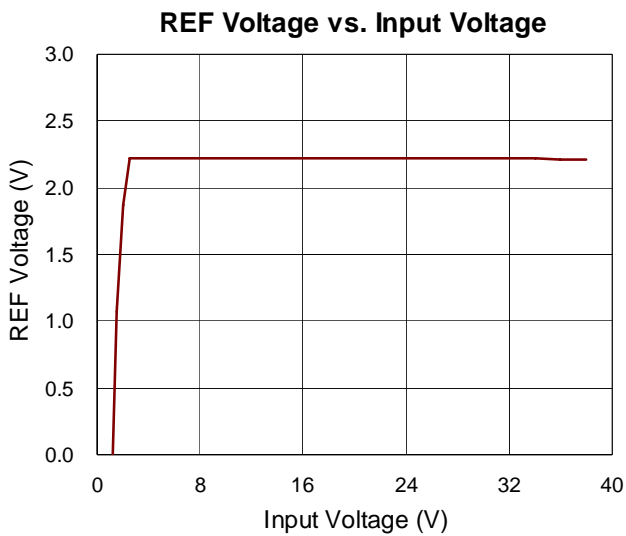
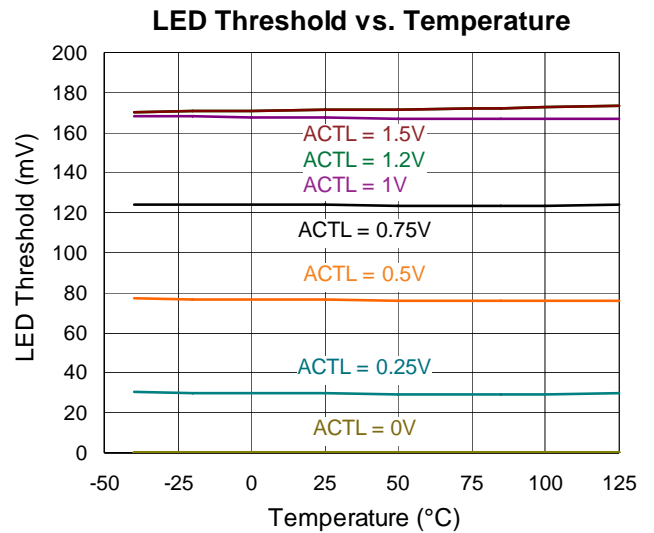
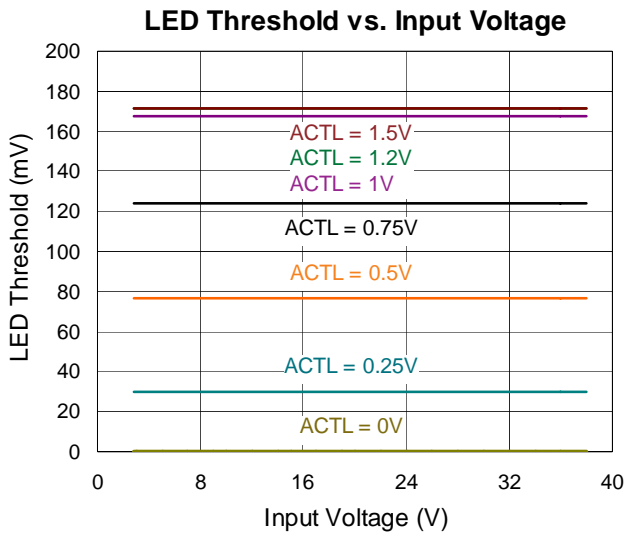
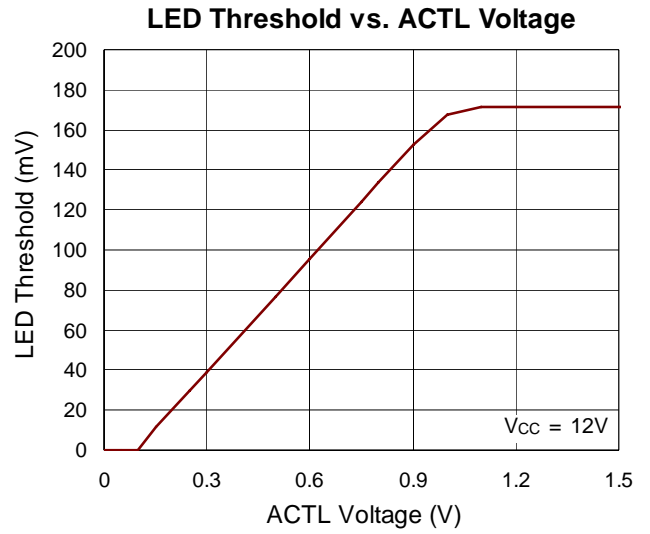
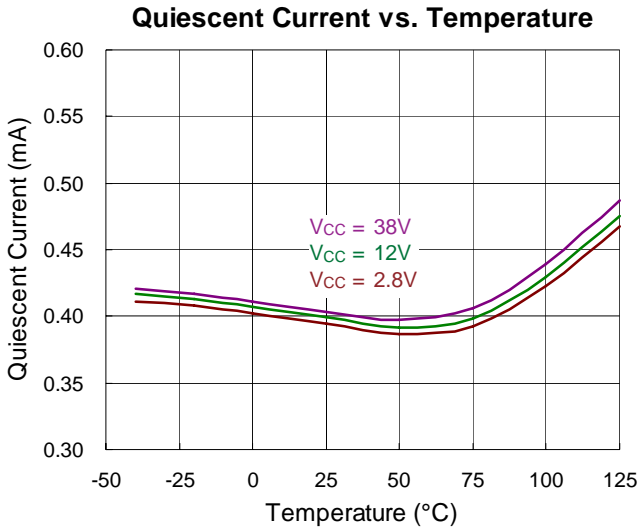

OVP Threshold vs. Input Voltage

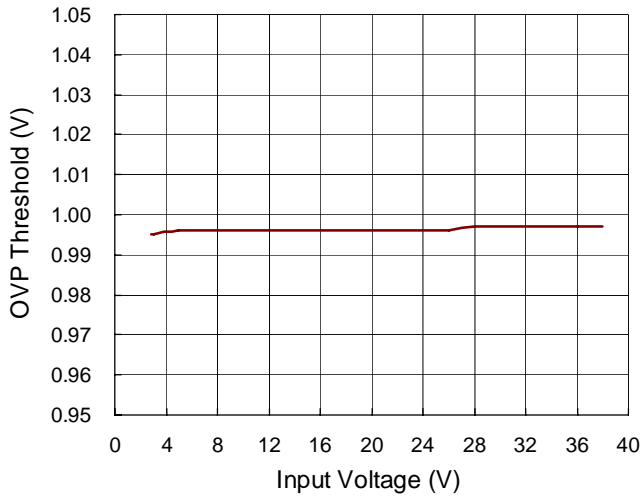

OVP Threshold vs. Temperature

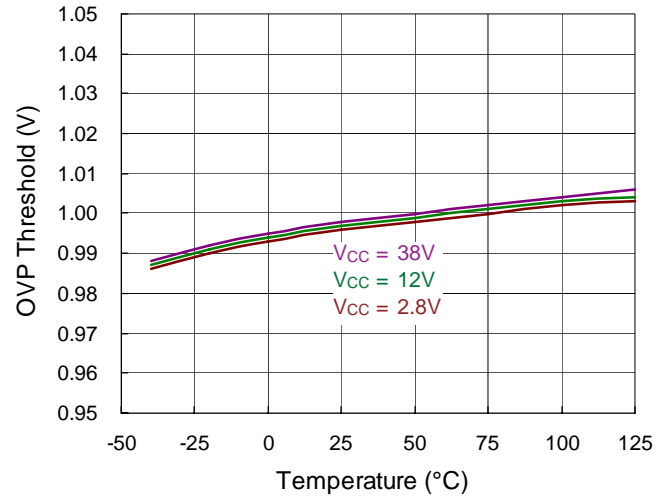

OUT Maximum Sink Current vs. Temperature

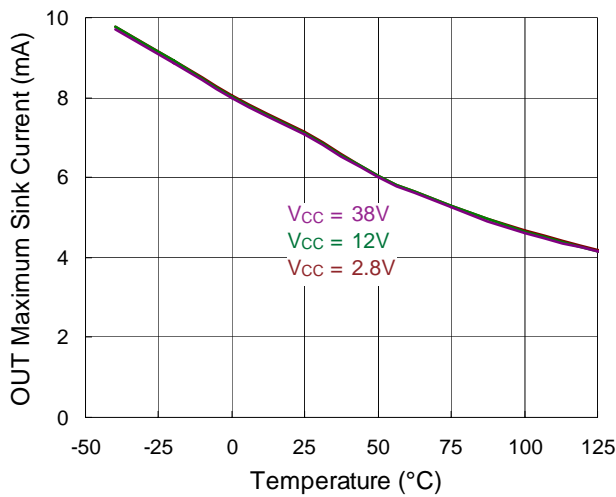

Application Information

Output Voltage Setting

The voltage control loop is controlled via the first trans-conductance operational amplifier. An opto-coupler is directly connected to the output and an external resistor bridge is connected between the output positive line and the ground reference. The relationship between R2 and R1 is shown below :

$$V_{OUT} = V_{OVP} \times \frac{(R1 + R2)}{R2}$$

where V_{OUT} is the desired maximum output voltage. To avoid discharge of the load, the resistor bridge, R1 and R2, should be highly resistive. For this type of application, a total value of 100kΩ (or more) would be appropriate for the resistors, R1 and R2.

Output Current Setting

The current control loop is controlled via the second trans-conductance operational amplifier. An opto-coupler and sense resistor, R_S , are placed in series on the output negative line. The sense voltage threshold is achieved externally via a resistor bridge tied to the reference voltage, V_{REF} . The output current that flows through the LEDs is set by an external resistor, R_S , which is connected between the LED and GND terminal. The relationship between output current, I_{OUT} , and R_S is shown in below equation :

$$I_{OUT} = \frac{170mV}{R_S}$$

where I_{OUT} is the desired maximum output current and the sense voltage threshold for the current control loop. Note that the sense resistor, R_S , should be chosen after taking into account its maximum power dissipation (P_{LIMIT}) during full load operation.

Analog Dimming Control

The ACTL terminal is driven by an external voltage, V_{ACTL} , to adjust the output current to an average value set by R_S . The voltage range for V_{ACTL} to adjust the output current is from 0.09V to 1.1V. When V_{ACTL} is larger than 0.09V, the output current value will just be set by the external resistor (R_S).

$$I_{OUTavg} = (170mV / R_S) \times \frac{(V_{ACTL} - 0.09)}{1.01}$$

Compensation

Both the voltage control trans-conductance amplifier and the current control trans-conductance amplifier are fully compensated. The output and negative inputs are directly accessible for external compensation components, as shown in the Typical Application Circuit.

The typical component values for the compensation network of voltage control loop is $C_{IC2} = 2.2nF$ and $R_{IC2} = 22k\Omega$. The typical component value for the compensation network of current control loop is $C_{IC1} = 2.2nF$, $R_{IC1} = 22k\Omega$ and $R_{IC2} = 1k\Omega$. However, in many applications, the current control loop can be stable without compensation network.

When the voltage control loop is used as the voltage limit protection or the current control loop is used as the current limit protection, no compensation network is needed for the protecting control loop.

A resistor, R_{LED} , must be connected in series with the opto-coupler since it is part of the compensation network. Although the value of R_{LED} is not critical, it's recommended to be in the range from 0.33kΩ to $(V_{OUT} - V_{OPTO} - 1) / I_{OUTH}$ Ω, where I_{OUTH} is recommended to be less than 10mA.

Thermal Considerations

For continuous operation, do not exceed absolute maximum junction temperature. The maximum power dissipation depends on the thermal resistance of the IC package, PCB layout, rate of surrounding airflow, and difference between junction and ambient temperature. The maximum power dissipation can be calculated by the following formula :

$$P_{D(MAX)} = (T_{J(MAX)} - T_A) / \theta_{JA}$$

where $T_{J(MAX)}$ is the maximum junction temperature, T_A is the ambient temperature, and θ_{JA} is the junction to ambient thermal resistance.

For recommended operating condition specifications, the maximum junction temperature is 125°C. The junction to ambient thermal resistance, θ_{JA} , is layout dependent. For SOP-8 package, the thermal resistance, θ_{JA} , is 188°C/W

on a standard JEDEC 51-7 four-layer thermal test board. The maximum power dissipation at $T_A = 25^\circ\text{C}$ can be calculated by the following formula :

$$P_{D(\text{MAX})} = (125^\circ\text{C} - 25^\circ\text{C}) / (188^\circ\text{C}/\text{W}) = 0.53\text{W for SOP-8 package}$$

The maximum power dissipation depends on the operating ambient temperature for fixed $T_{J(\text{MAX})}$ and thermal resistance, θ_{JA} . The derating curve in Figure 1 allows the designer to see the effect of rising ambient temperature on the maximum power dissipation.

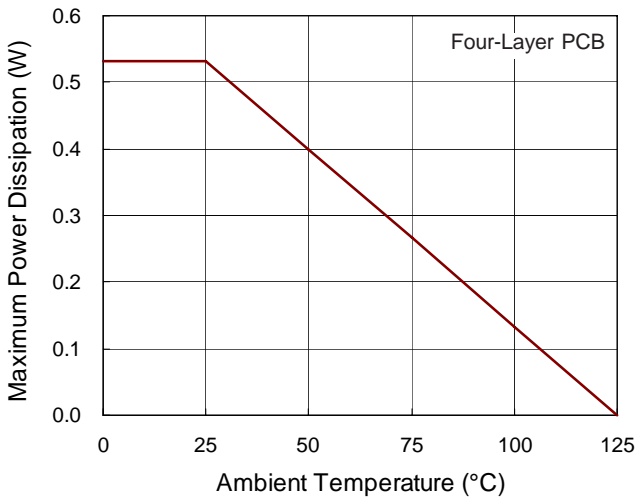

Figure 1. Derating Curve of Maximum Power Dissipation

Layout Considerations

For best performance of the RT8457A, the following PCB layout guidelines must be strictly followed.

- ▶ The hold-up capacitor, C1, must be placed as close to the VCC pin as possible.
- ▶ GND should be connected to a strong ground plane.
- ▶ R_S should be connected in a short trace between the RT8457A GND pin and LED pin.
- ▶ Keep the input/output traces as wide and short as possible.

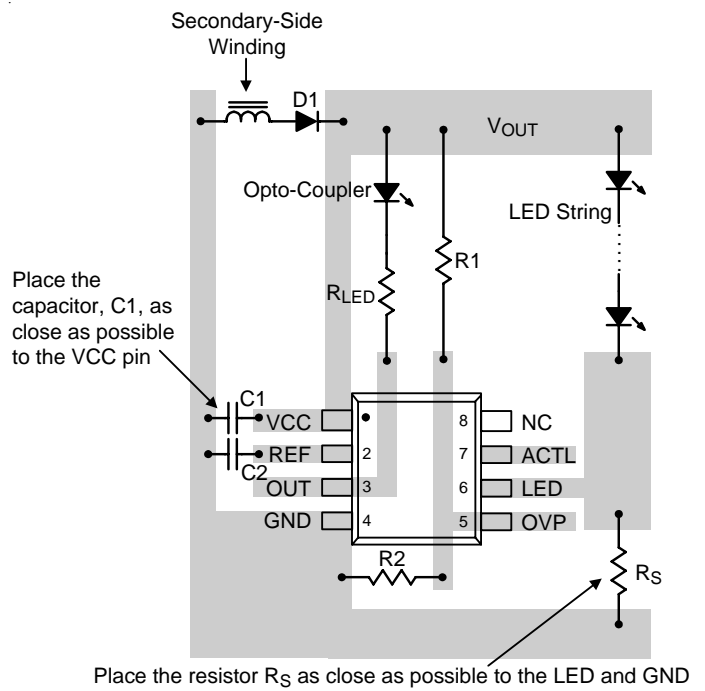
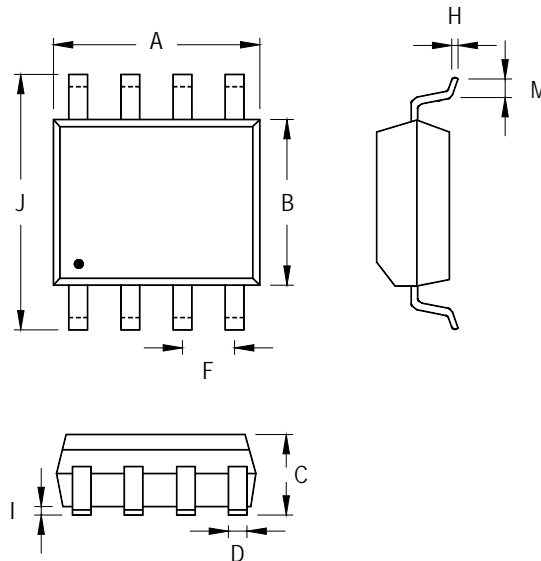

Figure 2. PCB Layout Guide

Outline Dimension



Symbol	Dimensions In Millimeters		Dimensions In Inches	
	Min	Max	Min	Max
A	4.801	5.004	0.189	0.197
B	3.810	3.988	0.150	0.157
C	1.346	1.753	0.053	0.069
D	0.330	0.508	0.013	0.020
F	1.194	1.346	0.047	0.053
H	0.170	0.254	0.007	0.010
I	0.050	0.254	0.002	0.010
J	5.791	6.200	0.228	0.244
M	0.400	1.270	0.016	0.050

8-Lead SOP Plastic Package

Richtek Technology Corporation

14F, No. 8, Tai Yuen 1st Street, Chupei City
 Hsinchu, Taiwan, R.O.C.
 Tel: (8863)5526789

Richtek products are sold by description only. Richtek reserves the right to change the circuitry and/or specifications without notice at any time. Customers should obtain the latest relevant information and data sheets before placing orders and should verify that such information is current and complete. Richtek cannot assume responsibility for use of any circuitry other than circuitry entirely embodied in a Richtek product. Information furnished by Richtek is believed to be accurate and reliable. However, no responsibility is assumed by Richtek or its subsidiaries for its use; nor for any infringements of patents or other rights of third parties which may result from its use. No license is granted by implication or otherwise under any patent or patent rights of Richtek or its subsidiaries.