



IEC Inlet Filters FN 9280

SCHAFFNER
energy efficiency and reliability

Ultra Compact and Versatile Filtered Power Entry Module



- Single stage filter
- Ultra compact design
- Rated currents up to 10A
- dual-fuse holder
- Fuses Ø5x20mm
- 2-pole rocker switch
- Good attenuation performance
- Faston or spring cage terminals

Approvals



RoHS

(CQC except HI-types)

Technical specifications

Mechanical life:	50,000 cycles
High potential test voltage:	P → PE 2000VAC for 2 sec (standard types) P → PE 2500VAC for 2 sec (B types) P → N 760VAC for 2 sec
MTBF @ 40°C/230V (Mil-HB-217F):	> 1,000,000 hours
Temperature range (operation and storage):	-25°C to +85°C (25/85/21)
Design corresponding to:	UL 1283, CSA 22.2 No. 8 1986, EN60939, EN60950, EN60601-1, UL544, EN60320
Flammability corresponding to:	UL 94V-2 or better
Maximum continuous operating voltage:	250VAC, 50/60Hz
Rated currents:	1 to 10 A* @ 40°C max.
Operating frequency:	50 to 400Hz
Switch ratings:	
USA (UL) and Canada (C-UL):	10A, 125VAC; 10A, 250VAC; 1/3HP
Europe (ENEC):	10A (4A), 250VAC**
Electrical specifications:	Inrush current 82A 6,000 on-off operations according to UL 1054 10,000 on-off operations according to ENEC
Leakage current:	Standard: <500uA at 250VAC/50 Hz Medical: <5uA at 250VAC/50 Hz
Protection category:	IP40 according to IEC 60529 (front side)
Fuse holder:	2fuses (Ø5 x 20mm) max. 250V
Terminals:	IP20 spring cage safe against finger touch
Spring cage wire range:	0.2 – 1.5 mm ² / 24 – 16 AWG single or flexible wire
Rocker switch:	2-pole, dark not illuminated, Marking I - 0

* 10A version is 8A UL approved

** Value in () relates to the inductive current charge: $\cos \gamma = 0.65$

The FN 9280 power entry module combines an IEC inlet, a mains filter and a dual fuse holder with a 2-pole rocker switch in an ultra compact housing. Choosing FN 9280/90 product line brings you the rapid availability of a standard filter associated with the necessary safety acceptances and a high attenuation performance. For higher attenuation performance the FN 9290 family with a dual stage filter and identical panel cut-out can be used. Standard IEC connector filters are a practical solution to pass EMI system approval in a short time. A wide selection of amperage ratings, mounting possibilities and also filters for medical applications are designed to offer you the best solution.

Features and benefits

- Good conducted attenuation performance, based on chokes with high saturation resistance and excellent thermal behavior
- Deep-drawn iron-sheet housing for best possible shielding against magnetic fields
- Rear/front flange mounting or snap-in versions
- Dual fuse holder
- 2-pole rocker switch
- Faston or spring cage terminals for more flexible assembly
- Medical version (B Type) according IEC / EN60601-1
- Spare fuse holder

Typical electrical schematic

FN 9280 Standard types (B types without Cy)

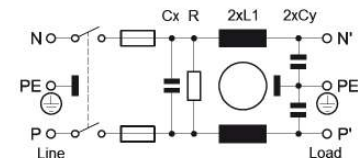

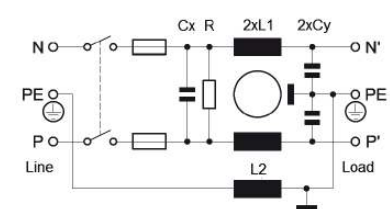

FN 9280 E types (B types without Cy)



Typical applications

- Portable electrical and electronic equipment
- Consumer goods
- EDP and office equipment
- Single-phase power supplies, switch-mode power supplies
- Test and measurement equipment
- Medical electrical devices (MD) and *In-Vitro*-Diagnostics (IVD) equipment

Filter selection table

Filter*	Rated current @ 40°C [A]	Leakage current** @ 250V ~/50Hz [uA]	Inductance		Capacitance		Resistance [kOhm]	Output connections		Weight [g]
			L1 [mH]	L2	Cx [nF]	R				
FN 9280-1-..	1	311	10.9	0	220	2.2	1000	-06	-100	101
FN 9280-2-..	2	311	4.4	0	220	2.2	1000	-06	-100	102
FN 9280-4-..	4	311	1.7	0	220	2.2	1000	-06	-100	105
FN 9280-6-..	6	311	0.78	0	220	2.2	1000	-06	-100	104
FN 9280-10-..	10	311	0.32	0	220	2.2	1000	-06	-100	106
FN 9280B-1-..	1	2	10.9	0	220	0	1000	-06	-100	101
FN 9280B-2-..	2	2	4.4	0	220	0	1000	-06	-100	102
FN 9280B-4-..	4	2	1.7	0	220	0	1000	-06	-100	105
FN 9280B-6-..	6	2	0.78	0	220	0	1000	-06	-100	104
FN 9280B-10-..	10	2	0.32	0	220	0	1000	-06	-100	106
FN 9289-1-..	1	311	10.9	0	220	2.2	1000	-06	-100	101
FN 9289-2-..	2	311	4.4	0	220	2.2	1000	-06	-100	102
FN 9289-4-..	4	311	1.7	0	220	2.2	1000	-06	-100	105
FN 9289-6-..	6	311	0.78	0	220	2.2	1000	-06	-100	104
FN 9289-10-..	10	311	0.32	0	220	2.2	1000	-06	-100	106
FN 9289B-1-..	1	2	10.9	0	220	0	1000	-06	-100	101
FN 9289B-2-..	2	2	4.4	0	220	0	1000	-06	-100	102
FN 9289B-4-..	4	2	1.7	0	220	0	1000	-06	-100	105
FN 9289B-6-..	6	2	0.78	0	220	0	1000	-06	-100	104
FN 9289B-10-..	10	2	0.32	0	220	0	1000	-06	-100	106
FN 9280E-1-..	1	311	10.9	0.4	220	2.2	1000	-06	-100	135
FN 9280E-2-..	2	311	4.4	0.4	220	2.2	1000	-06	-100	136
FN 9280E-4-..	4	311	1.66	0.4	220	2.2	1000	-06	-100	137
FN 9280E-6-..	6	311	0.78	0.4	220	2.2	1000	-06	-100	138
FN 9280E-10-..	10	311	0.32	0.4	220	2.2	1000	-06	-100	139
FN 9280BE-1-..	1	2	10.9	0.4	220	0	1000	-06	-100	135
FN 9280BE-2-..	2	2	4.4	0.4	220	0	1000	-06	-100	136
FN 9280BE-4-..	4	2	1.66	0.4	220	0	1000	-06	-100	137
FN 9280BE-6-..	6	2	0.78	0.4	220	0	1000	-06	-100	138
FN 9280BE-10-..	10	2	0.32	0.4	220	0	1000	-06	-100	139
FN 9289E-1-..	1	311	10.9	0.4	220	2.2	1000	-06	-100	135
FN 9289E-2-..	2	311	4.4	0.4	220	2.2	1000	-06	-100	136
FN 9289E-4-..	4	311	1.66	0.4	220	2.2	1000	-06	-100	137
FN 9289E-6-..	6	311	0.78	0.4	220	2.2	1000	-06	-100	138
FN 9289E-10-..	10	311	0.32	0.4	220	2.2	1000	-06	-100	139
FN 9289BE-1-..	1	2	10.9	0.4	220	0	1000	-06	-100	135
FN 9289BE-2-..	2	2	4.4	0.4	220	0	1000	-06	-100	136
FN 9289BE-4-..	4	2	1.66	0.4	220	0	1000	-06	-100	137
FN 9289BE-6-..	6	2	0.78	0.4	220	0	1000	-06	-100	138
FN 9289BE-10-..	10	2	0.32	0.4	220	0	1000	-06	-100	139

* To compile a complete part number, please replace the -.. with the required output connection style (e.g. FN 9289-1-06, FN 9282-4-100)

** Maximum leakage current under normal conditions according to IEC 60939-1 Ed. 3 at 250V AC.

Product selector

FN 92www-xx-yy-zz

Blank:	Snap in range 1.0 to 2.5 mm
Optional: 30:	Snap in range >2.5 to 3.5 mm
06:	Fast-On 6.3 x 0.8 mm (spade/soldering)
100:	Spring cage
1 to 10:	Rated current [A]
Blank:	Standard version
B:	Medical version (without Y2-capacitor)
Optional: E:	Earth line choke
BE:	Medical version (without YZ-capacitor) with earth line choke
0:	Flange version vertical/horizontal/front/rear mounting set
9:	Snap-in version, snapper on horizontal side (top / bottom)
Optional: 1:	Rear Flange mounting (top / bottom)
2:	Front Flange mounting (top / bottom)
3:	Rear Flange mounting (left / right)
4:	Front Flange mounting (left / right)
8:	Snap-in version, snapper on vertical side (left / right)
8:	Single stage filter
9:	Dual stage filter

All FN 9280/FN 9290 are equipped with a dual fuse holder with a spare fuse holder.

Note: All FN 9280/FN 9280B/FN 9289/FN 9289B/FN 9290/FN 9290B/FN 9299/FN 9299B are stock types from our distribution partners.

Order Examples:

FN 9280B-6-100: Medical version of single stage, dual fuse EMC/EMI filter, flange set for vertical/horizontal/front/rear mounting, 6A, spring cage terminals, from stock available.

FN 9298-6-06-30: Dual stage, dual fuse EMC/EMI filter, snap-in version, snappers for snap-in panel thickness range >2.5 to 3.5 mm, snapper on vertical side, 6A, fast-on terminals, non-stock order type

Typical filter attenuation

FN 9280 Series | Per CISPR 17; A = 50Ω/50Ω sym; B = 50Ω/50Ω asym

1A types

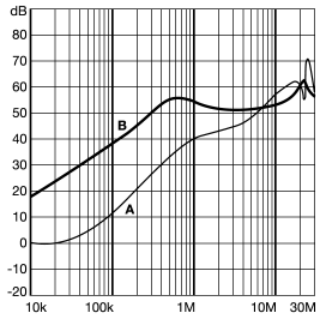

2A types

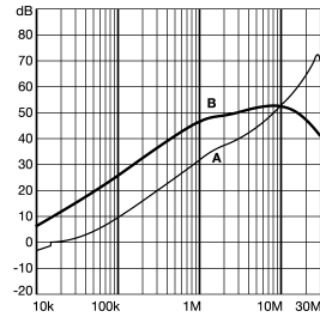

4 – 6A types

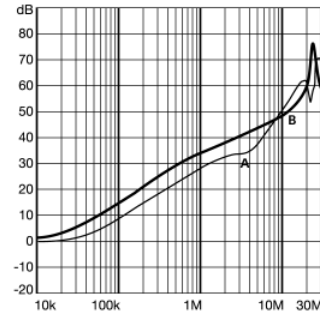

10A types

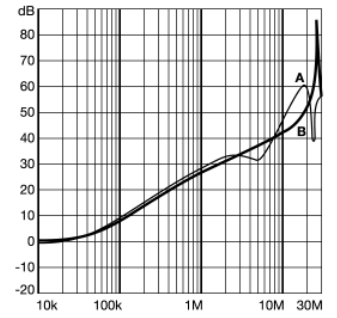

FN 9280B Series | Per CISPR 17; A = 50Ω/50Ω sym; B = 50Ω/50Ω asym

1A types

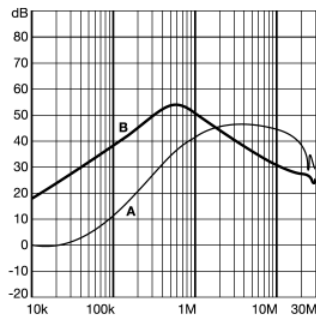

2A types

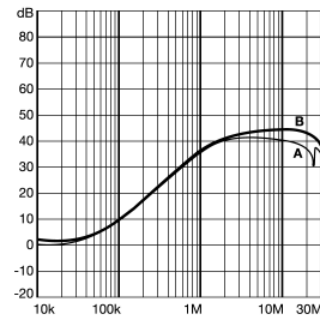

4 – 6A types

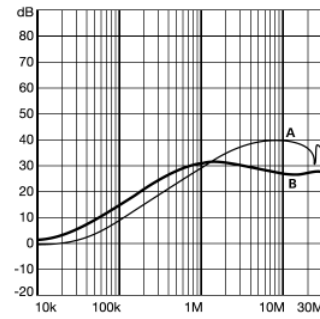

10A types

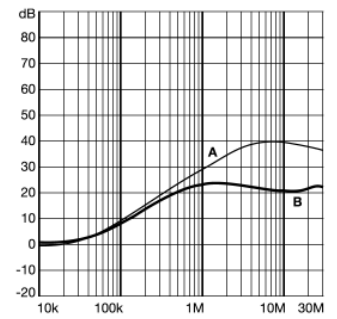

FN 9280E Series | Per CISPR 17; A = 50Ω/50Ω sym; B = 50Ω/50Ω asym

1A types

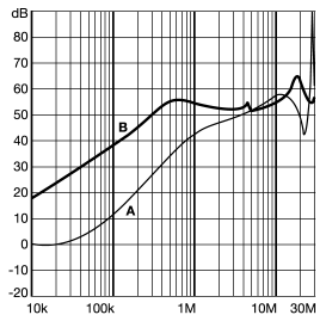

2A types

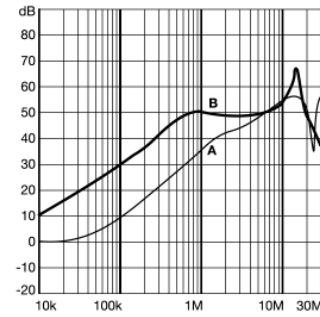

4 – 6A types

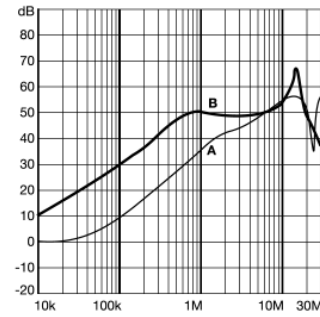

10A types

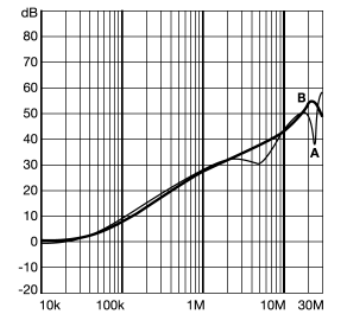

FN 9280BE Series | Per CISPR 17; A = 50Ω/50Ω sym; B = 50Ω/50Ω asym

1A types

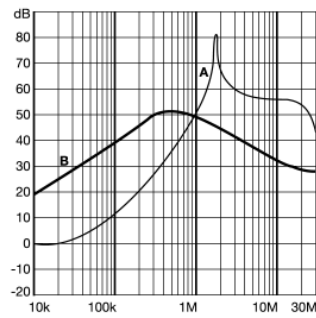

2A types

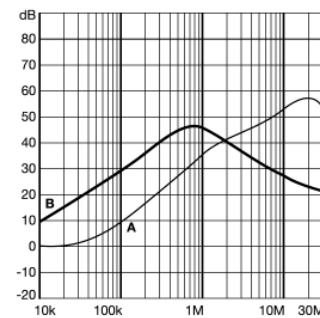

4 – 6A types

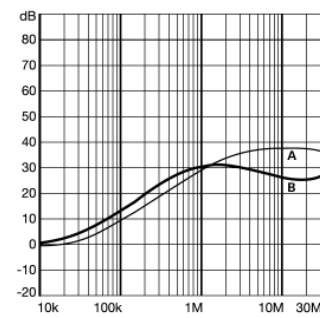

10A types

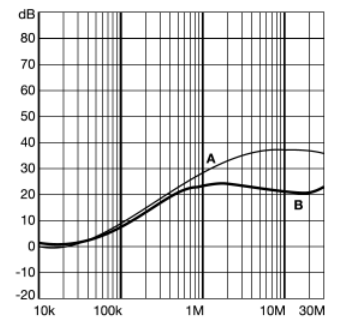

Mechanical Data:

FN 9280-x-06 / FN 9280B-x-06:

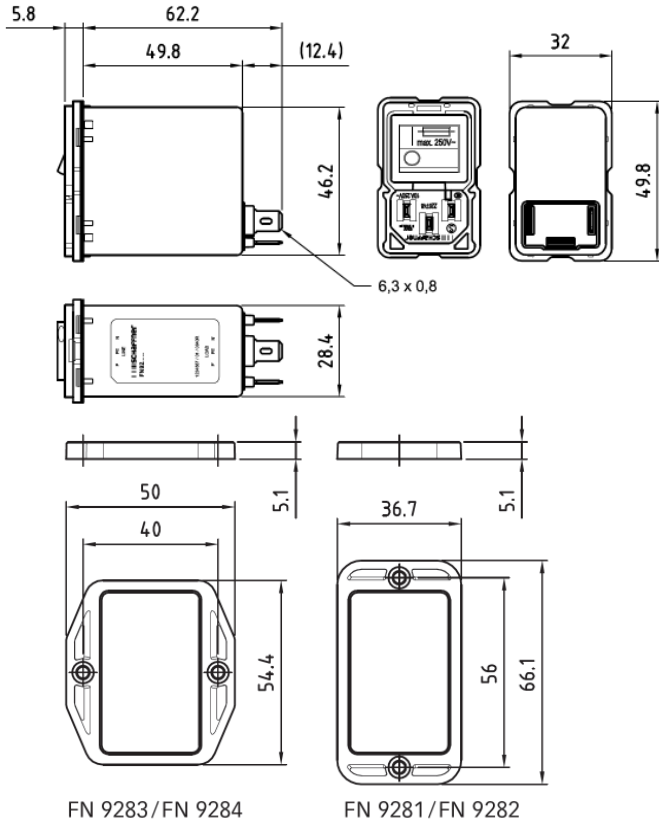

FN 9280-X-100 / FN 9280B-X-100:

Dimension (mm)

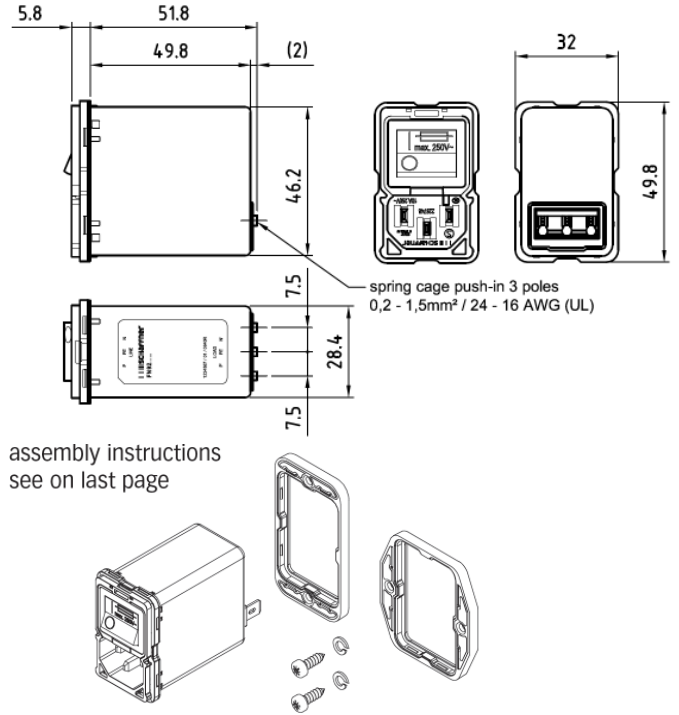

FN 9289-x-06 / FN 9289B-x-06:

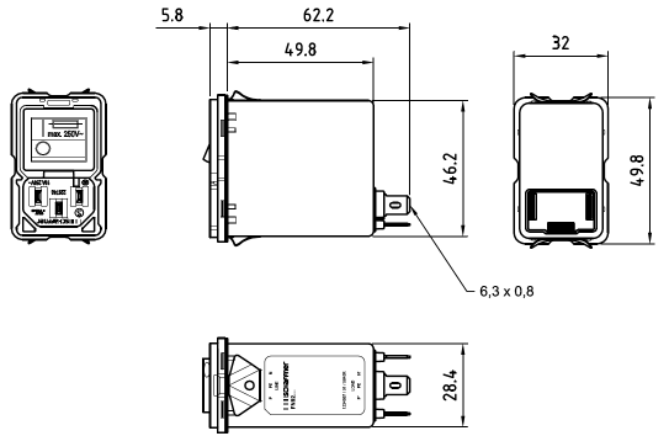

FN 9289-x-100 / FN 9289B-x-100:

Dimension (mm)

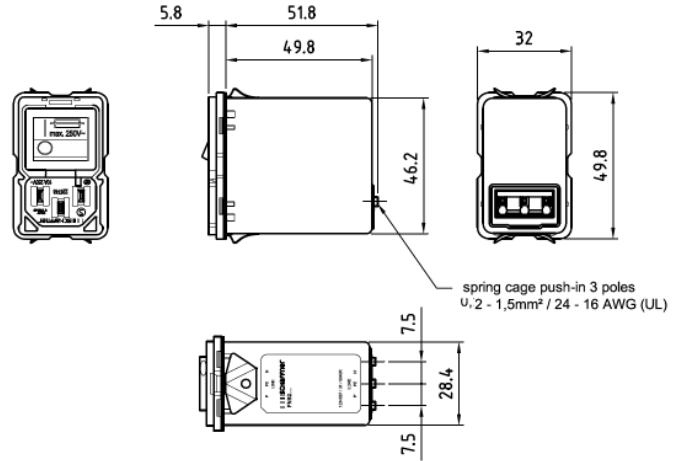

Panel cutout:

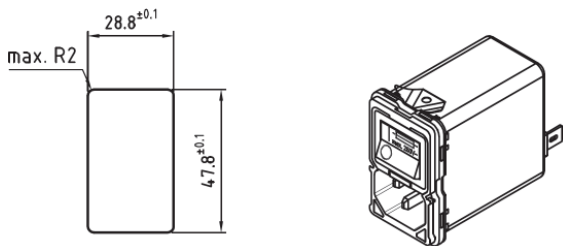

Panel cutout:

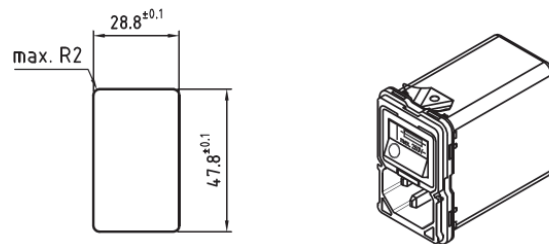

Assembly Instructions:

REAR MOUNTING

FRONT MOUNTING

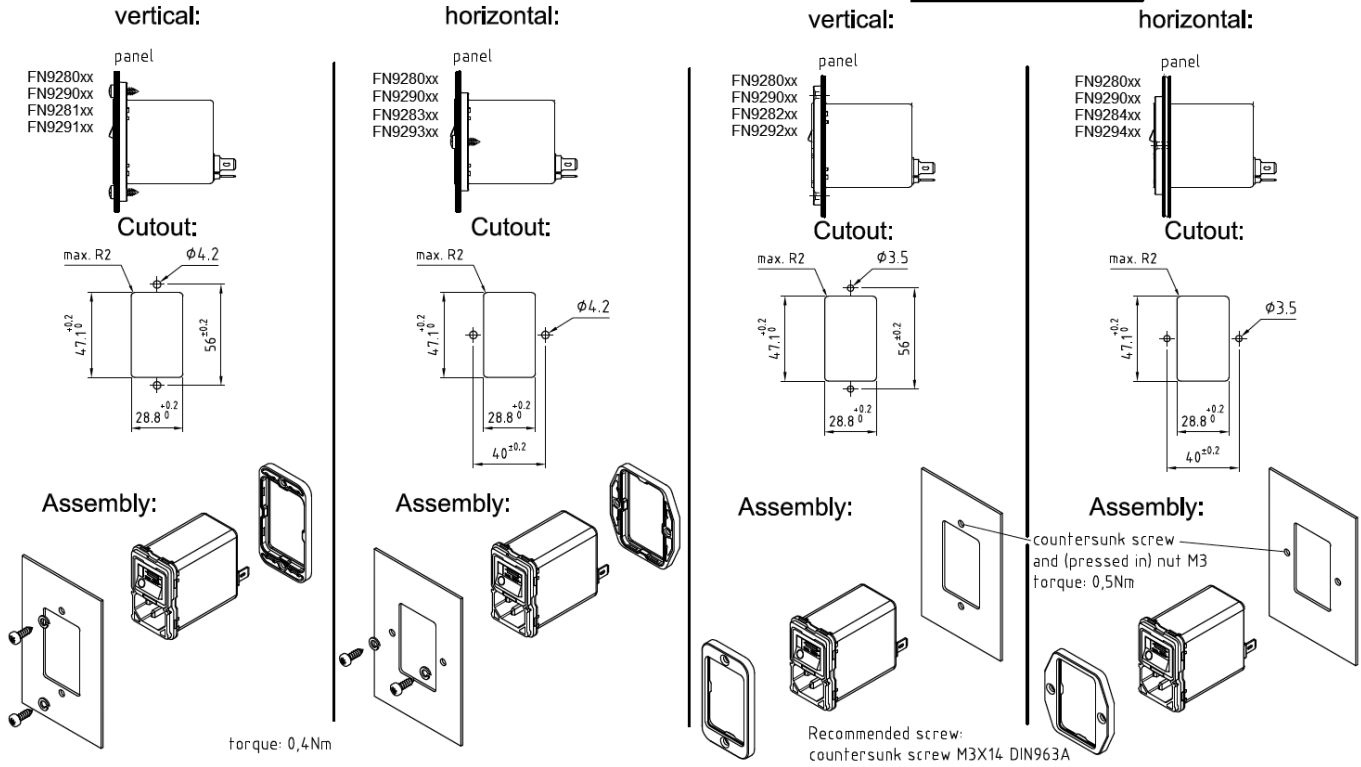

Terminal -100

clamping range, solid wire / flex wire	0,20 mm ² – 1,5 mm ² , AWG24 – AWG16
operating force of slider	max. 40N
recommended stripped length	8mm

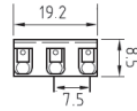

Push the knob above the terminal to insert the wire.

Removal of the combined switch / fuse holder unit

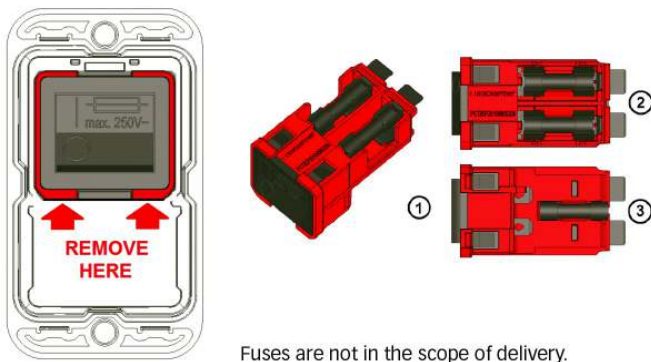

An additional fuse mark on the switch indicates the fuses holders behind the switch. The red frame shows the outline of the removable unit.

With a simple tool like a Swiss Army knife or a screwdriver No 1 or smaller the unit (1) can be removed from the filter. On the topside (2) behind the switch there are two fuse holders for each live connection. On the bottom side (3) is a clip to carry an additional spare fuse.

**Headquarters, global innovation
and development center**

Schaffner Group

Nordstrasse 11
4542 Luterbach
Switzerland
T +41 32 681 66 26
F +41 32 681 66 30
info@schaffner.com
www.schaffner.com

To find your local partner within
Schaffner's global network, please go
to www.schaffner.com

© 2012 Schaffner Group
Specifications are subject to change
without notice. The latest version of the
data sheets can be obtained from the
website. All trademarks recognized.

Schaffner is an ISO-registered
company.

Its products are designed and
manufactured under the strict quality
and environmental requirements of
the ISO 9001 and ISO 14001
standards.

This document has been carefully
checked. However, Schaffner does not
assume any liability for errors or
inaccuracies.

Sales and application centers

China

Schaffner EMC Ltd. Shanghai
T20-3, No 565 Chuangye Road
Pudong New Area
201201 Shanghai
T +86 21 3813 9500
F F +86 21 3813 9501 / 02
cschina@schaffner.com
<http://www.schaffner.com.cn/>

Finland

Schaffner Oy
Sauvonrinne 19 H
08500 Lohja
T +358 19 35 72 71
finlandsales@schaffner.com

France

Schaffner EMC S.A.S.
112, Quai de Bezons
Boîte postale 133
95103 Argenteuil
T +33 1 34 34 30 60
F +33 1 39 47 02 28
francesales@schaffner.com

Germany

Schaffner Deutschland GmbH
Westring 18
33142 Büren
T +49 2951 60 01 0
F +49 2951 60 01 23
buerensales@schaffner.com

Italy

Schaffner EMC S.r.l.
Via Galileo Galilei 47
20092 Cinisello Balsamo (MI)
T +39 02 66 04 30 45/47
F +39 02 61 23 943
italysales@schaffner.com

Japan

Schaffner EMC K.K.
1-32-12, Kamiyama, Setagaya-ku
7F Mitsui-seimei Sangenjaya Bldg.
154-0011 Tokyo
T +81 3 5712 3650
F +81 3 5712 3651
japansales@schaffner.com
<http://www.schaffner.jp>

Singapore

Schaffner EMC Pte Ltd.
Blk 3015A Ubi Road 1
05-09 Kampong Ubi Industrial Estate
408705 Singapore
T +65 6377 3283
F +65 6377 3281
singaporesales@schaffner.com

Spain

Schaffner EMC España
Calle Caléndula 93, Miniparc III, Edificio E
El Soto de la Moraleja Alcobendas
28109 Madrid
T +34 618 176 133
spainsales@schaffner.com

Sweden

Schaffner EMC AB
Turebergstorg 1, 6
19147 Sollentuna
T +46 8 5792 1121 / 22
F +46 8 92 96 90
swedensales@schaffner.com

Switzerland

Schaffner EMV AG
Nordstrasse 11
4542 Luterbach
T +41 32 6816 626
F +41 32 6816 641
sales@schaffner.ch

Taiwan R.O.C.

Schaffner EMV Ltd.
6 Floor, No. 413
Rui Guang Road
114 Neihu District Taipei City
T +886 2 87525050
F +886 2 87518086
taiwansales@schaffner.com

Thailand

Schaffner EMC Co. Ltd.
Northern Region Industrial Estate
67 Moo 4 Tambon Ban Klang Amphur Muangng
P.O. Box 14
51000 Lamphun
T +66 53 58 11 04
F +66 53 58 10 19
thailandsales@schaffner.com

UK

Schaffner Ltd.
5 Ashville Way
Molly Millars Lane Wokingham
RG41 2PL Berkshire
T +44 118 9770070
F +44 118 9792969
uksales@schaffner.com
<http://www.schaffner.uk.com>

USA

Schaffner EMC Inc.
52 Mayfield Avenue
08837 Edison
T 1-800-367-5566
T 732-225-9533
F 732-225-4789
usasales@schaffner.com
<http://www.schaffner.com/us>