

Global Connector Technology Ltd. - USB3065: Micro USB Receptacle, Type B, 5 Pin, Surface Mount, Horizontal, Bottom Mount (Standard), Optional Plastic Locating Peg

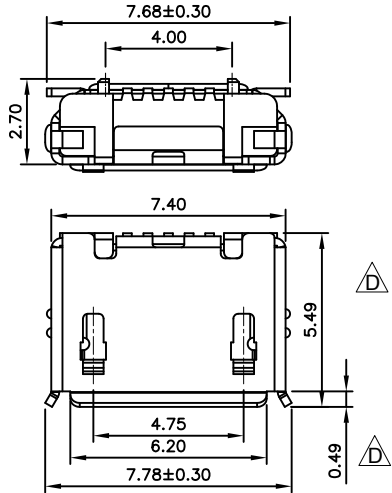

Designed to comply with physical, electrical and environmental requirements of Micro USB Standard (USB2.0).

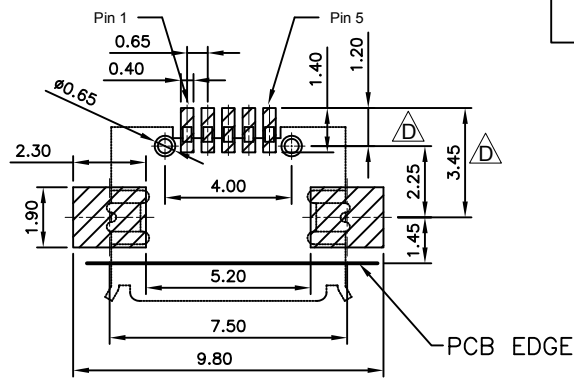
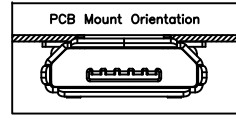

RECOMMENDED P.C.B LAYOUT
GENERAL TOLERANCE: ±0.05
AS VIEWED FROM COMPONENT SIDE
Solder Area
Component Outline

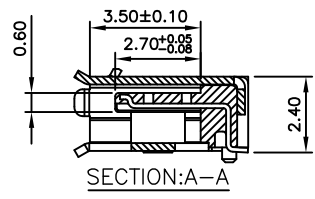
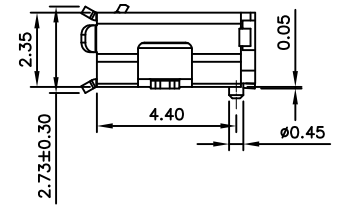
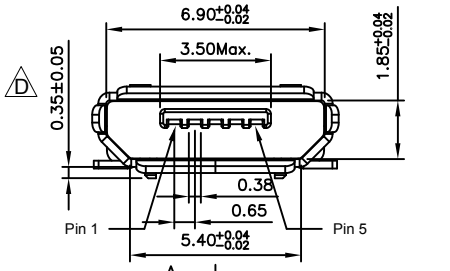
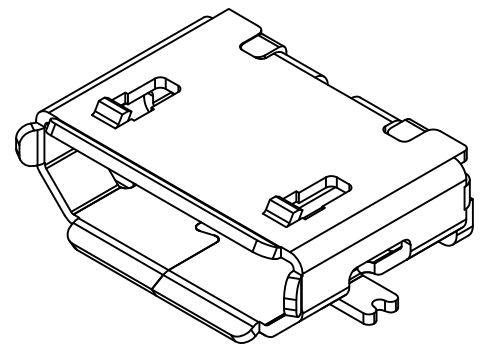

Specifications 规格:

Materials 材料:

Plastic Housing 塑胶外壳: LCP, UL94V-0, Black, LCP, UL94V-0 黑色
Contact Terminal 接触端子: Copper Alloy 铜合金
Metallic Shell 金属外壳: Stainless Steel 不锈钢 SUS 304 T = 0.25mm

Plating 电镀:

Underplating 底层电镀: 50µ" Nickel, 50µ" 镍
Finish 表面处理: Contact Area 接触面积: 30µ" Gold plating, 30µ" 镀金
Solder Tails 焊接末端: Gold Flash 镀金
Metallic Shell 金属外壳: Matte Tin 雾锡

Electrical 电气规格:

Voltage Rating 电压额定值: 100 V AC
Current Rating 电流额定值: Signal (Pins 2, 3, 4) 信号: 1.0A
Power (Pins 1, 5) 电源: 1.8A
Operating Temperature 工作温度: -30°C to +85°C
Contact Resistance 接触电阻值: 30mΩ Max.
Insulating Resistance 绝缘电阻值: 1000MΩ Min.
Dielectric Withstand Voltage 耐电压: 500V AC/Minute

Mechanical 机械性规格:

Mating Force 插入力: 35N Max.
Unmating Force 拔出力: 10N Min.
Durability 耐久性: 10,000 Cycles

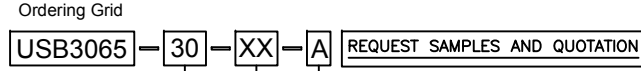
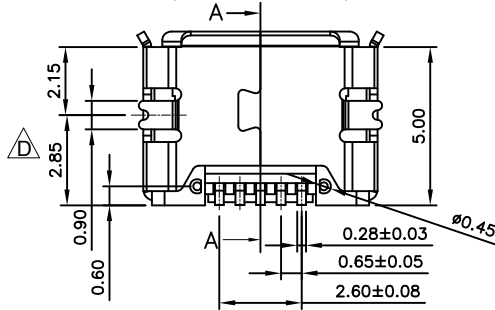

Contact Plating
30 = 30µ" Gold
Packing Options
A = Tape & Reel
(1.5K per Reel)
Optional Plastic Locating Peg
00 = Without Peg (Standard)
01 = With Peg

By	SA	CM	AJO	ASE	AJO
DETAIL	DRAWING RELEASE	DRAWING UPDATE	SPECIFICATION CHANGES	PCN: USB3065-001	PACKING CHANGE
REV	A	B	C	D	E
DATE	04/04/11	26/10/11	06/07/12	07/08/12	17/09/12



Tolerances (Except as noted)	Part Number:-	Date:-
Dimensions in mm	USB3065	04 APR 11
XX ± 0.2 X.X* ± 2°	Description:-	
X.XX ± 0.10 X.XX* ± 1°	µ USB RECEPTACLE, TYPE B, HORIZONTAL, SMT, BOTTOM MOUNT, OPTIONAL LOCATING PEG	
X.XXX ± 0.05 X.XXX* ± 0.5°		
Third Angle Projection	THIS DRAWING IS CONFIDENTIAL AND MUST NOT BE COPIED OR DISCLOSED WITHOUT WRITTEN CONSENT	



Scale	Revision	Material	Drawn by	Sheet No.
NTS	E	See Note	SA	E & OE 1/2

Global Connector Technology Ltd. - USB3065: Micro USB Receptacle, Type B, 5 Pin, Surface Mount, Horizontal, Bottom Mount (Standard), Optional Plastic Locating Peg

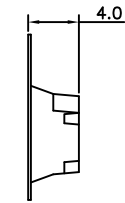
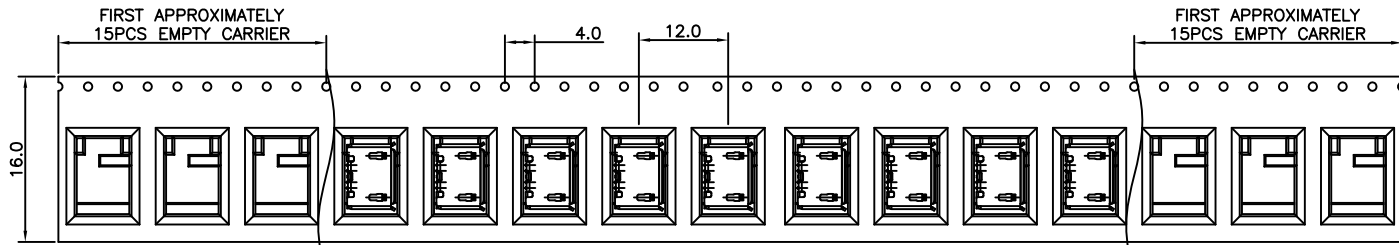

Products P/N	PCS/Reel	Reels/Carton	PCS/Carton
USB3065-30-XX-A	1500	4	6000

- Notes注意:
1. Peeling off force of top tape: 0.1-1.3N
 2. Part Conforms to EIA-481-C Standards 产品符合EIA-481-C标准
 3. All dimensions in millimeters 所有尺寸均是毫米
 4. 10 sprocket hole pitch cumulative tolerance±0.2mm

I/O Direction
卷盤繞逆時針方向轉動

Cover Tape
蓋帶

Peel of Angle
剝皮角度

Carrier Tape
載帶

Reel 卷筒

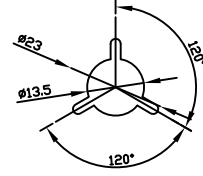

Detail F

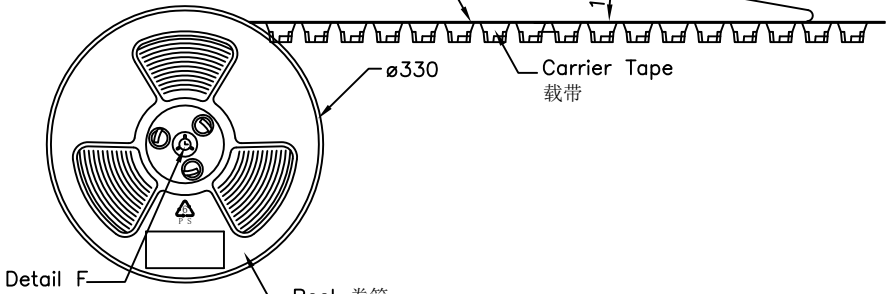

1500 pieces/reel
1500 件/卷



4 Reels
4 卷轴

Waterproof bag
防水袋

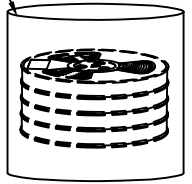

700x600x0.08

Cardboard
纸板

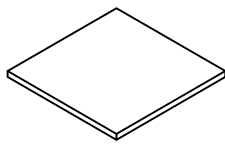
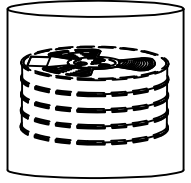
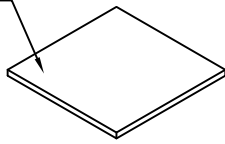

Triangle Liner
三角形班轮

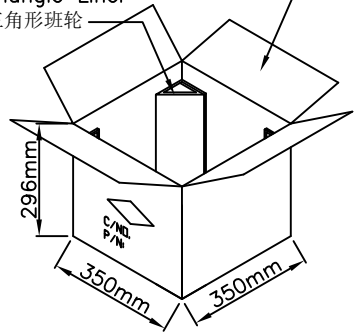

Carton
纸箱

By	SA	CM	AJO	ASE	AJO
DETAIL	DRAWING RELEASE	DRAWING UPDATE	SPECIFICATION CHANGES	PCN: USB3065-001	PACKING CHANGE
REV DATE	A 04/04/11	B 26/10/11	C 06/07/12	D 07/08/12	E 17/09/12



Tolerances (Except as noted)	Part Number:- USB3065	Date:- 04 APR 11
Dimensions in mm	Description:- μ USB RECEPTACLE, TYPE B, HORIZONTAL, SMT, BOTTOM MOUNT, OPTIONAL LOCATING PEG	
THIS DRAWING IS CONFIDENTIAL AND MUST NOT BE COPIED OR DISCLOSED WITHOUT WRITTEN CONSENT		

GCT
www.gct.co

Scale NTS	Revision E	Material See Note	Drawn by SA	Sheet No. 2/2
--------------	---------------	----------------------	----------------	------------------