

## ***User's Guide for the TPS92641EVM***

This user's guide describes the characteristics, operation, and use of the TPS92641 evaluation module (EVM). This EVM contains Texas Instruments' TPS92641 IC configured as a WLED power solution providing a single-channel regulated current output to drive 10 LEDs connected in series running at 1 A. This EVM accepts logic level PWM dimming or analogy dimming control input. A high-efficiency single-inductor synchronous step-down (buck) converter topology is used. The current output is ideal for driving a WLED light bar in architecture lighting applications. This user's guide includes the EVM specifications, a schematic diagram, PCB layout artworks, recommended test setup and bill of materials to help the end user to implement the device in their specific application.

### **Contents**

1	Applications .....	2
2	TPS92641EVM Electrical Performance Specifications .....	2
3	Schematic and Bill of Materials .....	3
4	Connector Descriptions .....	5
	4.1 Input Connections .....	5
	4.2 Output Connections .....	6
	4.3 Test Point Connections .....	6
5	Test Requirements and Setup .....	7
	5.1 Hardware Requirements .....	7
	5.2 Hardware Setup .....	7
6	Typical Waveforms .....	8
7	TPS92641EVM Assembly Drawings and PCB Layout .....	10

### **List of Figures**

1	TPS92641EVM Schematic .....	3
2	TPS92641EVM Connector Descriptions .....	5
3	Test Connection Diagram of the TPS92641EVM .....	7
4	Waveforms of Power-up Transient of TPS92641EVM with $V_{IN} = 48 V_{DC}$ .....	8
5	Waveforms of Steady State Operation of TPS92641EVM with $V_{IN} = 48 V_{DC}$ .....	9
6	Waveforms of UDIM Operation of the TPS92641EVM with $V_{IN} = 48 V_{DC}$ .....	9
7	TPS92641EVM PCB Top View with Component Legend .....	10
8	TPS92641EVM PCB Top View .....	10
9	TPS92641EVM PCB Bottom View .....	11

### **List of Tables**

1	TPS92641EVM Electrical and Performance Specifications .....	2
2	Bill of Materials .....	4
3	Hardware Requirements for EVM Evaluation .....	7

## 1 Applications

LED driver and constant current regulator  
 Architectural LED lighting drivers  
 Automotive LED drivers  
 General LED illumination

## 2 TPS92641EVM Electrical Performance Specifications

Table 1 provides a summary of the TPS92641EVM performance specifications. All specifications are given for an ambient temperature of 25°C.

**Table 1. TPS92641EVM Electrical and Performance Specifications**

Parameter		Notes and Conditions <sup>(1)</sup>	Min	Typ	Max	Unit
<b>Input Characteristics</b>						
V <sub>IN</sub>	Input voltage		43	48	53	V
UDIM	UDIM logic high (PWM dimming)	F <sub>UDIM</sub> = 200 Hz	1.3		5.5	V
I <sub>Q</sub>	Input quiescent current	Device enable, V <sub>IN</sub> = 48 V, V <sub>UDIM</sub> = 1 V, no switching			3	mA
<b>Output Characteristics</b>						
V <sub>OUT</sub>	Output voltage	LED+ (TP5) to GND (TP4) <sup>(2)</sup>	32		33	V
I <sub>LED</sub>	LED current	R5 = 10 kΩ, R6 = 19.6 kΩ, R10 = 0.2 Ω	970	1000	1030	mA
<b>Systems Characteristics</b>						
F <sub>SW</sub>	Switching frequency	R1 = 32.4 kΩ, C6 = 1 nF, R7 = 340 kΩ, R8 = 22.6 kΩ	450		500	kHz

<sup>(1)</sup> Estimate the input current by solving the power balance equation,  $\text{eff} = P_{\text{OUT}} / P_{\text{IN}} = (V_{\text{OUT}} \times I_{\text{LED}}) / (V_{\text{IN}} \times I_{\text{IN}})$ , for I<sub>IN</sub> and estimating the efficiency to be a conservative 85%. For example, for V<sub>OUT</sub> = 32.5 V, V<sub>IN</sub> = 48 V and I<sub>LED</sub> = 1 A, then I<sub>IN</sub> = (32.5 V × 1 A) / (48 V × 0.85) = 0.797 A.

<sup>(2)</sup> This voltage is load dependent, the nominal forward voltage drop, V<sub>F</sub> of the LED used is 3.25 V per LED running at 1 A.

3 Schematic and Bill of Materials

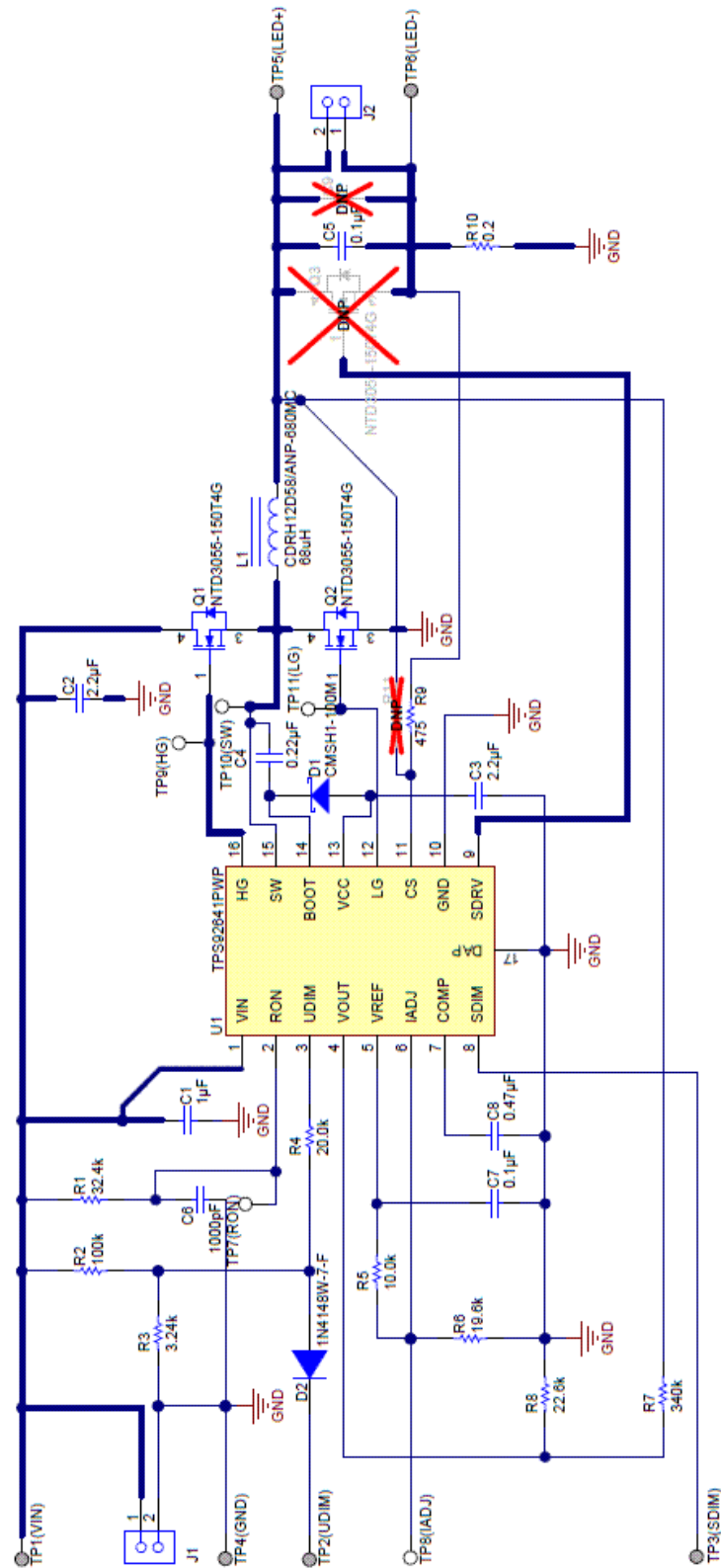

Figure 1. TPS92641EVM Schematic

**Table 2. Bill of Materials**

Designator	Value	Description	Size	Part Number	MFR
U1	TPS92641	Synchronous Buck Controller for Precision LED Drivers	16L TSSOP EXP PAD	TPS92641PWP	Texas Instruments
C1	1 $\mu$ F	Capacitor, Ceramic, 1 $\mu$ F, 100V, +/-10%, X7R	1210	GRM32ER72A105KA01L	MuRata
C2	2.2 $\mu$ F	Capacitor, Ceramic, 2.2 $\mu$ F, 100V, +/-10%, X7R	1210	GRM32ER72A225KA35L	MuRata
C3	2.2 $\mu$ F	Capacitor, Ceramic, 2.2 $\mu$ F, 16V, +/-10%, X5R	0603	GRM188R61C225KE15D	MuRata
C4	0.22 $\mu$ F	Capacitor, Ceramic, 0.22 $\mu$ F, 25V, +/-10%, X7R	0603	GRM188R71E224KA88D	MuRata
C5	0.1 $\mu$ F	Capacitor, Ceramic, 0.1 $\mu$ F, 50V, +/-10%, X7R	0603	GRM188R71E104KA93D	MuRata
C6	1000pF	Capacitor, Ceramic, 1000pF, 50V, +/-10%, X7R	0603	GRM188R71E102KA01D	MuRata
C7	0.1 $\mu$ F	Capacitor, Ceramic, 0.1 $\mu$ F, 25V, +/-10%, X7R	0603	GRM188R71E104KA01D	MuRata
C8	0.47 $\mu$ F	Capacitor, Ceramic, 0.47 $\mu$ F, 25V, +/-10%, X7R	0603	GRM188R71E474KA02D	MuRata
C9	1 $\mu$ F	Capacitor, Ceramic, 1 $\mu$ F, 50V, +/-10%, X7R (Not Populated)	1210	GRM32RR71H105KA01L	MuRata
D1	100V, 1A	Diode, Schottky, 100V, 1A	SMA	CMSH1-100M	Central Semi.
D2	100V, 0.15A	Diode, Ultrafast, 100V, 0.15A	SOD-123	1N4148W-7-F	Diode Inc.
L1	68 $\mu$ H	Inductor, Shielded Drum Core, Ferrite, 68 $\mu$ H	12 x 12 x 5.5mm	CDRH12D58/ANP-680NC	Sumida
Q1, Q2	60V, 9A	MOSFET, N-CH, 60V, 9A	DPAK	NTD3055-150T4G	ON Semi.
Q3	60V, 9A	MOSFET, N-CH, 60V, 9A ( Not Populated)	DPAK	NTD3055-150T4G	ON Semi
R1	32.4k $\Omega$	Resistor, 32.4k $\Omega$ , 1%, 0.1W	0603	CRCW060332K4FKEA	Vishay-Dale
R2	100k $\Omega$	Resistor, 100k $\Omega$ , 1%, 0.1W	0603	CRCW0603100KFKEA	Vishay-Dale
R3	3.24k $\Omega$	Resistor, 3.24k $\Omega$ , 1%, 0.1W	0603	CRCW060332K24FKEA	Vishay-Dale
R4	20k $\Omega$	Resistor, 20k $\Omega$ , 1%, 0.1W	0603	CRCW060320K0FKEA	Vishay-Dale
R5	10k $\Omega$	Resistor, 10k $\Omega$ , 1%, 0.1W	0603	CRCW060310K0FKEA	Vishay-Dale
R6	19.6k $\Omega$	Resistor, 19.6k $\Omega$ , 1%, 0.1W	0603	CRCW060319K6FKEA	Vishay-Dale
R7	340k $\Omega$	Resistor, 340k $\Omega$ , 1%, 0.1W	0603	CRCW0603340KFKEA	Vishay-Dale
R8	22.6k $\Omega$	Resistor, 22.6k $\Omega$ , 1%, 0.1W	0603	CRCW060322K6FKEA	Vishay-Dale
R9	475 $\Omega$	Resistor, 475 $\Omega$ , 1%, 0.1W	0603	CRCW0603475RFKEA	Vishay-Dale
R10	0.2 $\Omega$	Resistor, 0.2 $\Omega$ , 1%, 2W	2512	CSRN2512FKR200	Stackpole Electronics Inc.
R11	1.21M $\Omega$	Resistor, 1.21M $\Omega$ , 1%, 0.1W ( Not Populated)	0603	CRCW06031M21FKEA	Vishay-Dale
J1, J2		Conn Terminal Block, 2 Positions	5.08 Pitch	1715721	Phoenix Contact
TP1, TP2, TP3, TP4, TP5, TP6		Terminal, Turret, TH, Double		1502-2	Keystone
TP7, TP8, TP9, TP10, TP11		Test Point, TH, Miniature, White		5002	Keystone
H5, H6, H7, H8		Nylon Standoff	Hex, 0.5"L	1902C	Keystone
H1, H2, H3, H4		Nylon Screw	M3	NY PMS 440 0025 PH	B&F Fastener Supply

## 4 Connector Descriptions

The connector descriptions for this EVM are illustrated in [Figure 2](#).

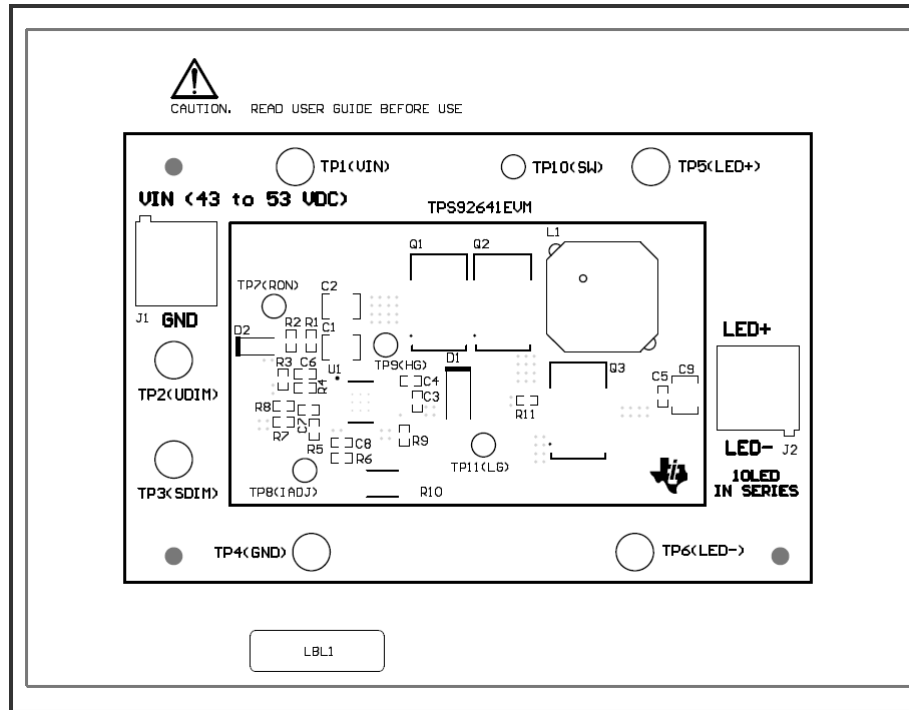

**Figure 2. TPS92641EVM Connector Descriptions**

### 4.1 Input Connections

The Input terminals of the TPS92641EVM are described in [Section 4.1.1](#) to [Section 4.1.5](#).

#### 4.1.1 VIN (J1)

The VIN terminal of J1 connector is the positive input terminal of the supply voltage to the EVM.

#### 4.1.2 GND (J1)

The GND terminal of the J1 connector is the ground input terminal of the supply voltage to the EVM.

#### 4.1.3 UDIM (TP2)

The UDIM terminal is the input terminal of the standard PWM dimming control signal to the device. This is the default dimming scheme of the EVM and accepts logic level PWM control signal.

#### 4.1.4 SDIM (TP3)

The SDIM terminal is the input terminal of the high-speed shunt FET PWM dimming control signal to the device. In order to use this feature, install Q3. Please also note that standard PWM dimming (UDIM) cannot be used with Q3 installed. Again, this input accepts the logic level PWM control signal.

#### 4.1.5 IADJ (TP8)

The IADJ terminal is the input of analog dimming control voltage. With R5 removed and C9 installed, the LED current can be controlled by the DC voltage level at IADJ terminal directly. The range of this control voltage is up to about 2 V with this EVM. True Zero LED current dimming can be achieved by installing R11 in place to off-set the zero LED current point.

## 4.2 Output Connections

The output terminals of the TPS92641EVM are described in [Section 4.2.1](#) and [Section 4.2.2](#).

### 4.2.1 LED+ (J2)

The LED+ terminal of the J2 connector is the positive output terminal of the EVM to the anode of the LED string.

### 4.2.2 LED- (J2)

The LED- terminal of the J2 connector is the negative output terminal of the EVM to the cathode of the LED string.

## 4.3 Test Point Connections

The test point terminals of the TPS92641EVM are described in [Section 4.3.1](#) to [Section 4.3.8](#).

### 4.3.1 TP1 (VIN)

The TP1 test point connected to the positive terminal of the supply voltage.

### 4.3.2 TP4 (GND)

The TP4 test point connected to the ground terminal of the supply voltage.

### 4.3.3 TP5 (LED+)

The TP5 test point connected to the positive output terminal of the EVM to the anode of the LED string.

### 4.3.4 TP6 (LED-)

The TP6 test point connected to the negative output terminal of the EVM to the cathode of the LED string

### 4.3.5 TP7 (RON)

The TP7 test point connected to the timing control pin, RON of the device to monitor the timing waveform.

### 4.3.6 TP9 (HG)

The TP9 test point connected to the high gate driver output pin, HG of the device to monitor the high gate waveform.

### 4.3.7 TP10 (SW)

The TP10 test point connected to the switching node of the converter, SW pin of the device to monitor the switching node waveform.

### 4.3.8 TP11 (LG)

The TP11 test point connected to the low gate driver output pin, LG of the device to monitor the low gate waveform.

## 5 Test Requirements and Setup

### 5.1 Hardware Requirements

The basic hardware requirements for EVM evaluation are listed in [Table 3](#).

**Table 3. Hardware Requirements for EVM Evaluation**

Item	Description	Characteristics
<b>Input Power Source</b>		
DC power supply	Generic DC power supply	43 V <sub>DC</sub> – 53 VDC, 1.5 A
<b>Load</b>		
LED load module	Power LED string of 10 LEDs connected in series and capable of running at 1-A current	Nominal forward voltage of the string in the range of 32 V <sub>DC</sub> to 35 V <sub>DC</sub> at 1 A
<b>Equipment</b>		
Digital Multimeters	Agilent HP34401 6½ digit DMM or equivalent DMM	
Signal Generator	Agilent 33220A or equivalent signal generator	
Oscilloscopes	Tektronix TDS3034B or equivalent for monitoring waveforms	

### 5.2 Hardware Setup

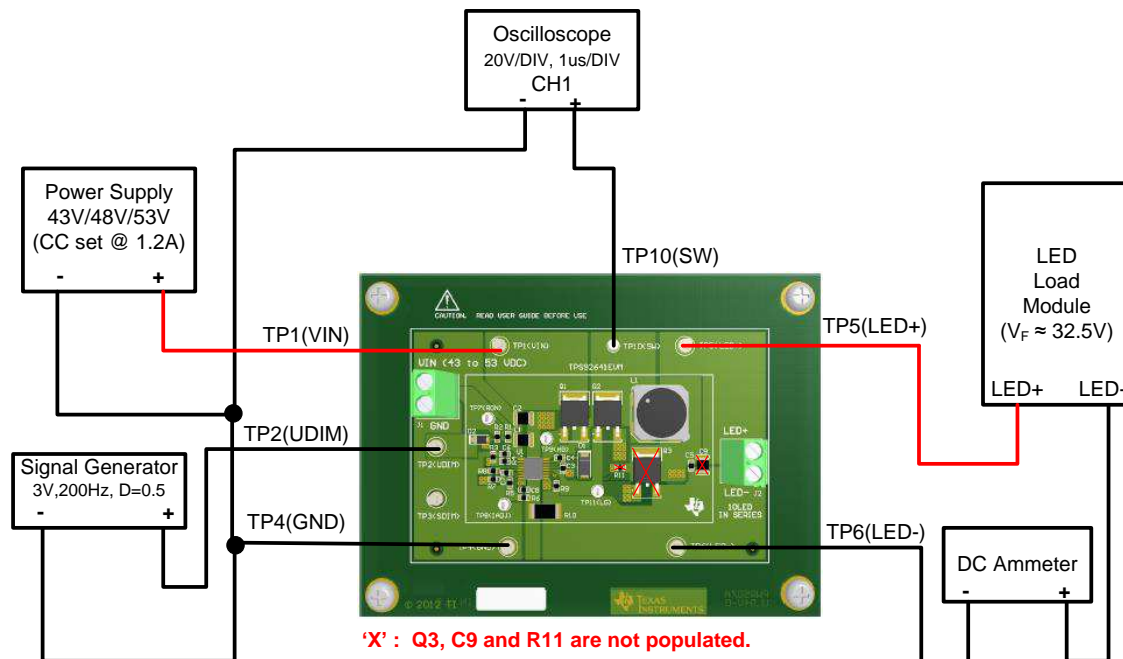

**Figure 3. Test Connection Diagram of the TPS92641EVM**

- CAUTION: LEDs are very bright; wearing safety glasses with dark lens is recommended.
- Setup the equipments and connect the test setup as shown in [Figure 3](#).
- Power-up the power supply and signal generator (Output OFF). Turn on the output of the power supply and measure LED current through the DC Ammeter and the input current from the power supply.
- Observe the waveform from the oscilloscope and record the switching frequency. Confirm the operation is stable with no jittering.
- Enable the output of the signal generator and measure LED current through the DC Ammeter and observe the switching waveform at the switching node.

## 6 Typical Waveforms

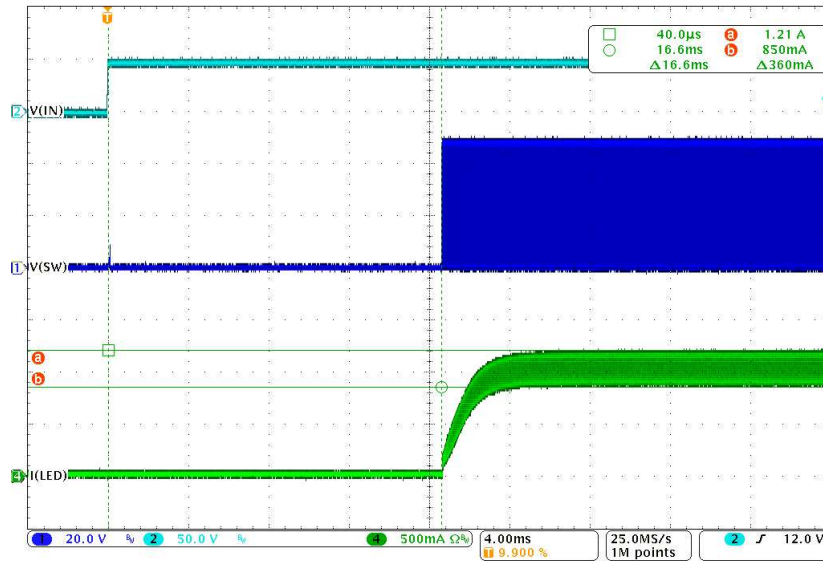

10 serial LEDs,  $T_A=25^\circ\text{C}$   
 $I_{LED}$ : 500 mA/DIV,  $V_{SW}$ : 20 V/DIV,  $V_{IN}$ : 50 V/DIV

Figure 4. Waveforms of Power-up Transient of TPS92641EVM with  $V_{IN} = 48 V_{DC}$

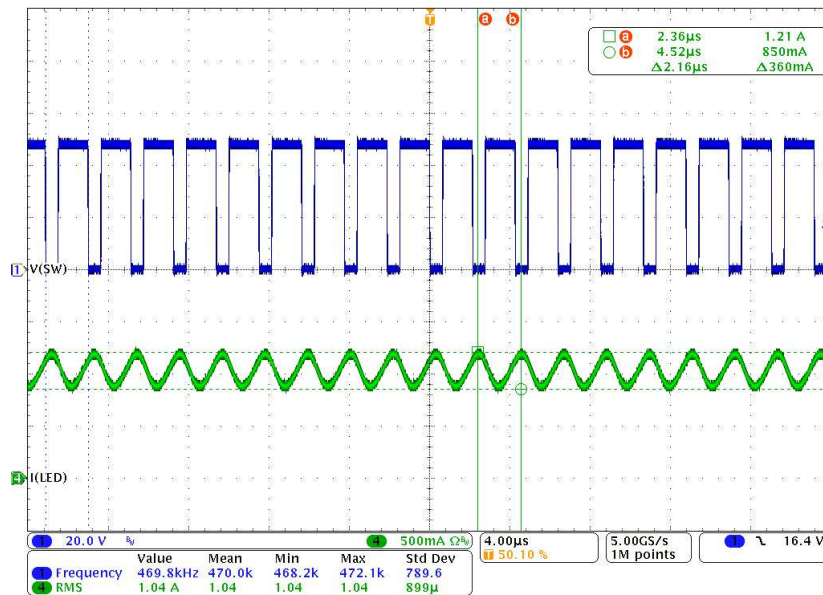

10 serial LEDs,  $T_A = 25^\circ\text{C}$   
 $I_{LED}$ : 500 mA/DIV,  $V_{SW}$ : 20 V/DIV

Figure 5. Waveforms of Steady State Operation of TPS92641EVM with  $V_{IN} = 48 V_{DC}$



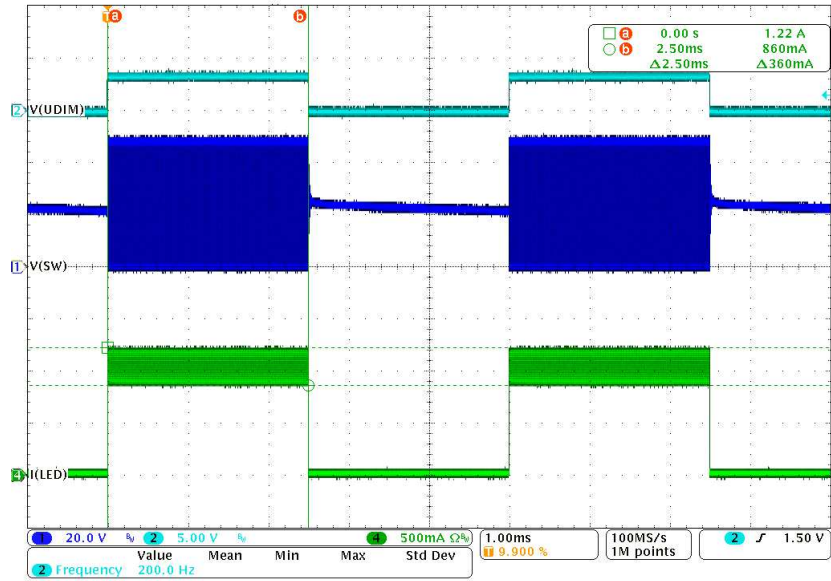

10 serial LEDs,  $T_A = 25^\circ\text{C}$   
 $I_{LED} = 500 \text{ mA/DIV}$ ,  $V_{UDIM} = 5 \text{ V/DIV}$ ,  $V_{SW} = 20 \text{ V/DIV}$

**Figure 6. Waveforms of UDIM Operation of the TPS92641EVM with  $V_{IN} = 48 \text{ V}_{DC}$**

7 TPS92641EVM Assembly Drawings and PCB Layout

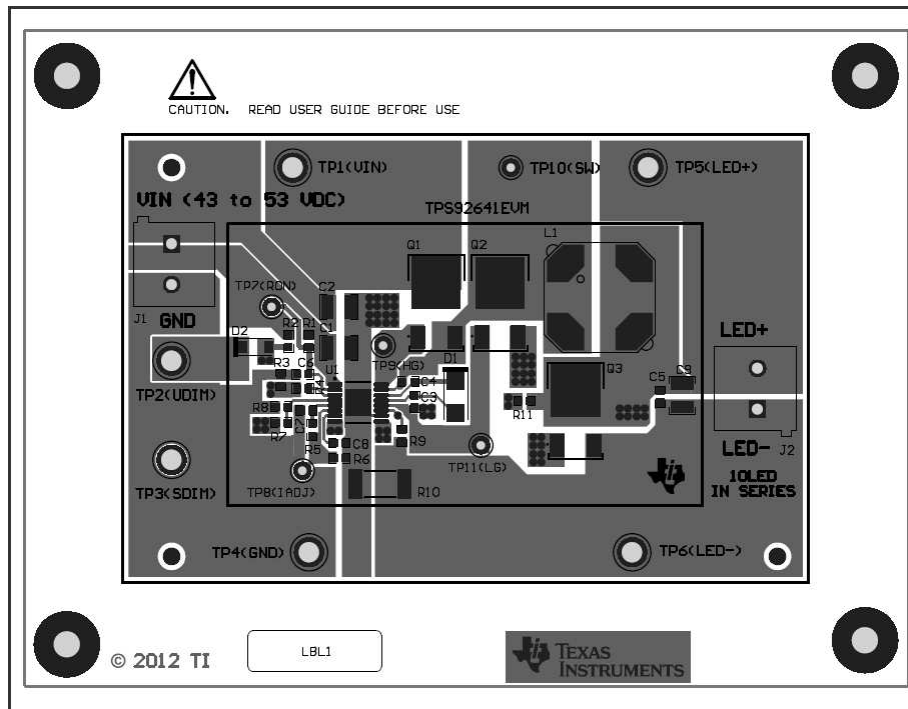

Figure 7. TPS92641EVM PCB Top View with Component Legend

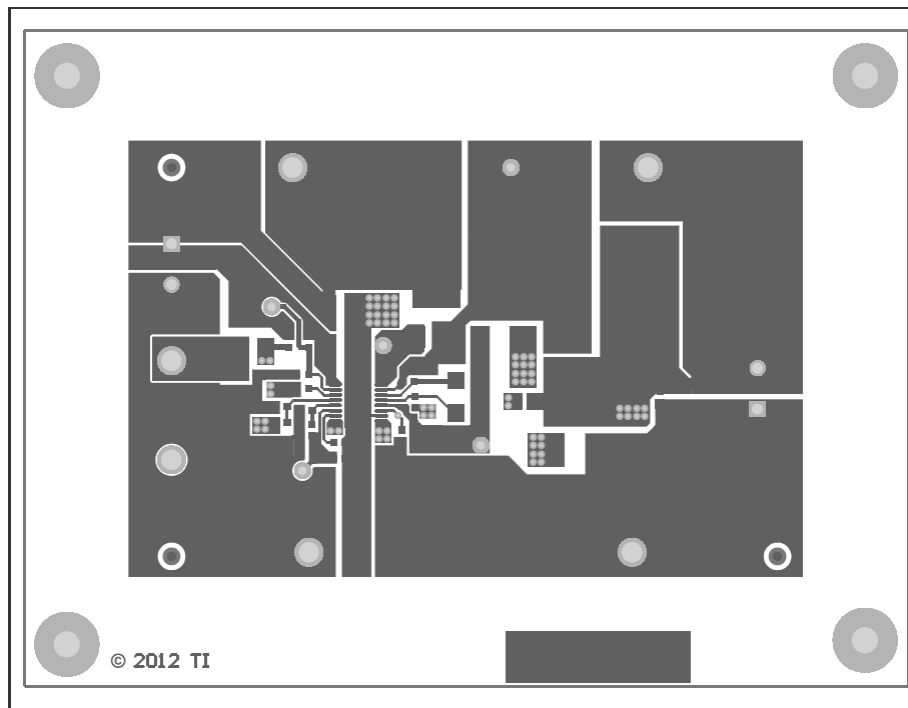
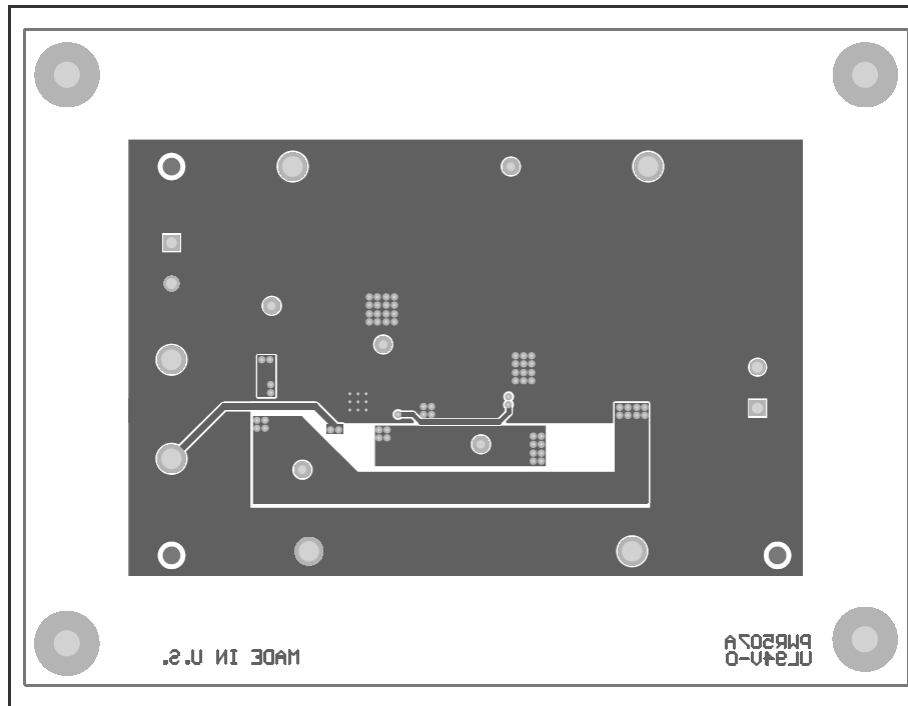

Figure 8. TPS92641EVM PCB Top View



**Figure 9. TPS92641EVM PCB Bottom View**

## EVALUATION BOARD/KIT/MODULE (EVM) ADDITIONAL TERMS

Texas Instruments (TI) provides the enclosed Evaluation Board/Kit/Module (EVM) under the following conditions:

The user assumes all responsibility and liability for proper and safe handling of the goods. Further, the user indemnifies TI from all claims arising from the handling or use of the goods.

Should this evaluation board/kit not meet the specifications indicated in the User's Guide, the board/kit may be returned within 30 days from the date of delivery for a full refund. THE FOREGOING LIMITED WARRANTY IS THE EXCLUSIVE WARRANTY MADE BY SELLER TO BUYER AND IS IN LIEU OF ALL OTHER WARRANTIES, EXPRESSED, IMPLIED, OR STATUTORY, INCLUDING ANY WARRANTY OF MERCHANTABILITY OR FITNESS FOR ANY PARTICULAR PURPOSE. EXCEPT TO THE EXTENT OF THE INDEMNITY SET FORTH ABOVE, NEITHER PARTY SHALL BE LIABLE TO THE OTHER FOR ANY INDIRECT, SPECIAL, INCIDENTAL, OR CONSEQUENTIAL DAMAGES.

Please read the User's Guide and, specifically, the Warnings and Restrictions notice in the User's Guide prior to handling the product. This notice contains important safety information about temperatures and voltages. For additional information on TI's environmental and/or safety programs, please visit [www.ti.com/esh](http://www.ti.com/esh) or contact TI.

No license is granted under any patent right or other intellectual property right of TI covering or relating to any machine, process, or combination in which such TI products or services might be or are used. TI currently deals with a variety of customers for products, and therefore our arrangement with the user is not exclusive. TI assumes no liability for applications assistance, customer product design, software performance, or infringement of patents or services described herein.

## REGULATORY COMPLIANCE INFORMATION

As noted in the EVM User's Guide and/or EVM itself, this EVM and/or accompanying hardware may or may not be subject to the Federal Communications Commission (FCC) and Industry Canada (IC) rules.

For EVMs **not** subject to the above rules, this evaluation board/kit/module is intended for use for ENGINEERING DEVELOPMENT, DEMONSTRATION OR EVALUATION PURPOSES ONLY and is not considered by TI to be a finished end product fit for general consumer use. It generates, uses, and can radiate radio frequency energy and has not been tested for compliance with the limits of computing devices pursuant to part 15 of FCC or ICES-003 rules, which are designed to provide reasonable protection against radio frequency interference. Operation of the equipment may cause interference with radio communications, in which case the user at his own expense will be required to take whatever measures may be required to correct this interference.

### General Statement for EVMs including a radio

*User Power/Frequency Use Obligations:* This radio is intended for development/professional use only in legally allocated frequency and power limits. Any use of radio frequencies and/or power availability of this EVM and its development application(s) must comply with local laws governing radio spectrum allocation and power limits for this evaluation module. It is the user's sole responsibility to only operate this radio in legally acceptable frequency space and within legally mandated power limitations. Any exceptions to this are strictly prohibited and unauthorized by Texas Instruments unless user has obtained appropriate experimental/development licenses from local regulatory authorities, which is responsibility of user including its acceptable authorization.

### For EVMs annotated as FCC – FEDERAL COMMUNICATIONS COMMISSION Part 15 Compliant

#### Caution

This device complies with part 15 of the FCC Rules. Operation is subject to the following two conditions: (1) This device may not cause harmful interference, and (2) this device must accept any interference received, including interference that may cause undesired operation.

Changes or modifications not expressly approved by the party responsible for compliance could void the user's authority to operate the equipment.

### FCC Interference Statement for Class A EVM devices

This equipment has been tested and found to comply with the limits for a Class A digital device, pursuant to part 15 of the FCC Rules. These limits are designed to provide reasonable protection against harmful interference when the equipment is operated in a commercial environment. This equipment generates, uses, and can radiate radio frequency energy and, if not installed and used in accordance with the instruction manual, may cause harmful interference to radio communications. Operation of this equipment in a residential area is likely to cause harmful interference in which case the user will be required to correct the interference at his own expense.

### **FCC Interference Statement for Class B EVM devices**

This equipment has been tested and found to comply with the limits for a Class B digital device, pursuant to part 15 of the FCC Rules. These limits are designed to provide reasonable protection against harmful interference in a residential installation. This equipment generates, uses and can radiate radio frequency energy and, if not installed and used in accordance with the instructions, may cause harmful interference to radio communications. However, there is no guarantee that interference will not occur in a particular installation. If this equipment does cause harmful interference to radio or television reception, which can be determined by turning the equipment off and on, the user is encouraged to try to correct the interference by one or more of the following measures:

- Reorient or relocate the receiving antenna.
- Increase the separation between the equipment and receiver.
- Connect the equipment into an outlet on a circuit different from that to which the receiver is connected.
- Consult the dealer or an experienced radio/TV technician for help.

### **For EVMs annotated as IC – INDUSTRY CANADA Compliant**

This Class A or B digital apparatus complies with Canadian ICES-003.

Changes or modifications not expressly approved by the party responsible for compliance could void the user's authority to operate the equipment.

### **Concerning EVMs including radio transmitters**

This device complies with Industry Canada licence-exempt RSS standard(s). Operation is subject to the following two conditions: (1) this device may not cause interference, and (2) this device must accept any interference, including interference that may cause undesired operation of the device.

### **Concerning EVMs including detachable antennas**

Under Industry Canada regulations, this radio transmitter may only operate using an antenna of a type and maximum (or lesser) gain approved for the transmitter by Industry Canada. To reduce potential radio interference to other users, the antenna type and its gain should be so chosen that the equivalent isotropically radiated power (e.i.r.p.) is not more than that necessary for successful communication.

This radio transmitter has been approved by Industry Canada to operate with the antenna types listed in the user guide with the maximum permissible gain and required antenna impedance for each antenna type indicated. Antenna types not included in this list, having a gain greater than the maximum gain indicated for that type, are strictly prohibited for use with this device.

Cet appareil numérique de la classe A ou B est conforme à la norme NMB-003 du Canada.

Les changements ou les modifications pas expressément approuvés par la partie responsable de la conformité ont pu vider l'autorité de l'utilisateur pour actionner l'équipement.

### **Concernant les EVMs avec appareils radio**

Le présent appareil est conforme aux CNR d'Industrie Canada applicables aux appareils radio exempts de licence. L'exploitation est autorisée aux deux conditions suivantes : (1) l'appareil ne doit pas produire de brouillage, et (2) l'utilisateur de l'appareil doit accepter tout brouillage radioélectrique subi, même si le brouillage est susceptible d'en compromettre le fonctionnement.

### **Concernant les EVMs avec antennes détachables**

Conformément à la réglementation d'Industrie Canada, le présent émetteur radio peut fonctionner avec une antenne d'un type et d'un gain maximal (ou inférieur) approuvé pour l'émetteur par Industrie Canada. Dans le but de réduire les risques de brouillage radioélectrique à l'intention des autres utilisateurs, il faut choisir le type d'antenne et son gain de sorte que la puissance isotrope rayonnée équivalente (p.i.r.e.) ne dépasse pas l'intensité nécessaire à l'établissement d'une communication satisfaisante.

Le présent émetteur radio a été approuvé par Industrie Canada pour fonctionner avec les types d'antenne énumérés dans le manuel d'usage et ayant un gain admissible maximal et l'impédance requise pour chaque type d'antenne. Les types d'antenne non inclus dans cette liste, ou dont le gain est supérieur au gain maximal indiqué, sont strictement interdits pour l'exploitation de l'émetteur.

## **【Important Notice for Users of this Product in Japan】**

### **This development kit is NOT certified as Confirming to Technical Regulations of Radio Law of Japan**

If you use this product in Japan, you are required by Radio Law of Japan to follow the instructions below with respect to this product:

1. Use this product in a shielded room or any other test facility as defined in the notification #173 issued by Ministry of Internal Affairs and Communications on March 28, 2006, based on Sub-section 1.1 of Article 6 of the Ministry's Rule for Enforcement of Radio Law of Japan,
2. Use this product only after you obtained the license of Test Radio Station as provided in Radio Law of Japan with respect to this product, or
3. Use of this product only after you obtained the Technical Regulations Conformity Certification as provided in Radio Law of Japan with respect to this product. Also, please do not transfer this product, unless you give the same notice above to the transferee. Please note that if you could not follow the instructions above, you will be subject to penalties of Radio Law of Japan.

**Texas Instruments Japan Limited**  
**(address) 24-1, Nishi-Shinjuku 6 chome, Shinjuku-ku, Tokyo, Japan**

<http://www.tij.co.jp>

#### **【ご使用にあたっての注】**

本開発キットは技術基準適合証明を受けておりません。

本製品のご使用に際しては、電波法遵守のため、以下のいずれかの措置を取っていただく必要がありますのでご注意ください。

1. 電波法施行規則第6条第1項第1号に基づく平成18年3月28日総務省告示第173号で定められた電波暗室等の試験設備でご使用いただく。
2. 実験局の免許を取得後ご使用いただく。
3. 技術基準適合証明を取得後ご使用いただく。

なお、本製品は、上記の「ご使用にあたっての注意」を譲渡先、移転先に通知しない限り、譲渡、移転できないものとします。

上記を遵守頂けない場合は、電波法の罰則が適用される可能性があることをご留意ください。

日本テキサス・インスツルメンツ株式会社  
東京都新宿区西新宿6丁目24番1号  
西新宿三井ビル

<http://www.tij.co.jp>

## EVALUATION BOARD/KIT/MODULE (EVM) WARNINGS, RESTRICTIONS AND DISCLAIMERS

**For Feasibility Evaluation Only, in Laboratory/Development Environments.** Unless otherwise indicated, this EVM is not a finished electrical equipment and not intended for consumer use. It is intended solely for use for preliminary feasibility evaluation in laboratory/development environments by technically qualified electronics experts who are familiar with the dangers and application risks associated with handling electrical mechanical components, systems and subsystems. It should not be used as all or part of a finished end product.

Your Sole Responsibility and Risk. You acknowledge, represent and agree that:

1. You have unique knowledge concerning Federal, State and local regulatory requirements (including but not limited to Food and Drug Administration regulations, if applicable) which relate to your products and which relate to your use (and/or that of your employees, affiliates, contractors or designees) of the EVM for evaluation, testing and other purposes.
2. You have full and exclusive responsibility to assure the safety and compliance of your products with all such laws and other applicable regulatory requirements, and also to assure the safety of any activities to be conducted by you and/or your employees, affiliates, contractors or designees, using the EVM. Further, you are responsible to assure that any interfaces (electronic and/or mechanical) between the EVM and any human body are designed with suitable isolation and means to safely limit accessible leakage currents to minimize the risk of electrical shock hazard.
3. You will employ reasonable safeguards to ensure that your use of the EVM will not result in any property damage, injury or death, even if the EVM should fail to perform as described or expected.
4. You will take care of proper disposal and recycling of the EVM's electronic components and packing materials.

**Certain Instructions.** It is important to operate this EVM within TI's recommended specifications and environmental considerations per the user guidelines. Exceeding the specified EVM ratings (including but not limited to input and output voltage, current, power, and environmental ranges) may cause property damage, personal injury or death. If there are questions concerning these ratings please contact a TI field representative prior to connecting interface electronics including input power and intended loads. Any loads applied outside of the specified output range may result in unintended and/or inaccurate operation and/or possible permanent damage to the EVM and/or interface electronics. Please consult the EVM User's Guide prior to connecting any load to the EVM output. If there is uncertainty as to the load specification, please contact a TI field representative. During normal operation, some circuit components may have case temperatures greater than 60°C as long as the input and output are maintained at a normal ambient operating temperature. These components include but are not limited to linear regulators, switching transistors, pass transistors, and current sense resistors which can be identified using the EVM schematic located in the EVM User's Guide. When placing measurement probes near these devices during normal operation, please be aware that these devices may be very warm to the touch. As with all electronic evaluation tools, only qualified personnel knowledgeable in electronic measurement and diagnostics normally found in development environments should use these EVMs.

**Agreement to Defend, Indemnify and Hold Harmless.** You agree to defend, indemnify and hold TI, its licensors and their representatives harmless from and against any and all claims, damages, losses, expenses, costs and liabilities (collectively, "Claims") arising out of or in connection with any use of the EVM that is not in accordance with the terms of the agreement. This obligation shall apply whether Claims arise under law of tort or contract or any other legal theory, and even if the EVM fails to perform as described or expected.

**Safety-Critical or Life-Critical Applications.** If you intend to evaluate the components for possible use in safety critical applications (such as life support) where a failure of the TI product would reasonably be expected to cause severe personal injury or death, such as devices which are classified as FDA Class III or similar classification, then you must specifically notify TI of such intent and enter into a separate Assurance and Indemnity Agreement.

Mailing Address: Texas Instruments, Post Office Box 655303, Dallas, Texas 75265  
Copyright © 2012, Texas Instruments Incorporated

## EVALUATION BOARD/KIT/MODULE (EVM) ADDITIONAL TERMS

Texas Instruments (TI) provides the enclosed Evaluation Board/Kit/Module (EVM) under the following conditions:

The user assumes all responsibility and liability for proper and safe handling of the goods. Further, the user indemnifies TI from all claims arising from the handling or use of the goods.

Should this evaluation board/kit not meet the specifications indicated in the User's Guide, the board/kit may be returned within 30 days from the date of delivery for a full refund. THE FOREGOING LIMITED WARRANTY IS THE EXCLUSIVE WARRANTY MADE BY SELLER TO BUYER AND IS IN LIEU OF ALL OTHER WARRANTIES, EXPRESSED, IMPLIED, OR STATUTORY, INCLUDING ANY WARRANTY OF MERCHANTABILITY OR FITNESS FOR ANY PARTICULAR PURPOSE. EXCEPT TO THE EXTENT OF THE INDEMNITY SET FORTH ABOVE, NEITHER PARTY SHALL BE LIABLE TO THE OTHER FOR ANY INDIRECT, SPECIAL, INCIDENTAL, OR CONSEQUENTIAL DAMAGES.

Please read the User's Guide and, specifically, the Warnings and Restrictions notice in the User's Guide prior to handling the product. This notice contains important safety information about temperatures and voltages. For additional information on TI's environmental and/or safety programs, please visit [www.ti.com/esh](http://www.ti.com/esh) or contact TI.

No license is granted under any patent right or other intellectual property right of TI covering or relating to any machine, process, or combination in which such TI products or services might be or are used. TI currently deals with a variety of customers for products, and therefore our arrangement with the user is not exclusive. TI assumes no liability for applications assistance, customer product design, software performance, or infringement of patents or services described herein.

## REGULATORY COMPLIANCE INFORMATION

As noted in the EVM User's Guide and/or EVM itself, this EVM and/or accompanying hardware may or may not be subject to the Federal Communications Commission (FCC) and Industry Canada (IC) rules.

For EVMs **not** subject to the above rules, this evaluation board/kit/module is intended for use for ENGINEERING DEVELOPMENT, DEMONSTRATION OR EVALUATION PURPOSES ONLY and is not considered by TI to be a finished end product fit for general consumer use. It generates, uses, and can radiate radio frequency energy and has not been tested for compliance with the limits of computing devices pursuant to part 15 of FCC or ICES-003 rules, which are designed to provide reasonable protection against radio frequency interference. Operation of the equipment may cause interference with radio communications, in which case the user at his own expense will be required to take whatever measures may be required to correct this interference.

### General Statement for EVMs including a radio

*User Power/Frequency Use Obligations:* This radio is intended for development/professional use only in legally allocated frequency and power limits. Any use of radio frequencies and/or power availability of this EVM and its development application(s) must comply with local laws governing radio spectrum allocation and power limits for this evaluation module. It is the user's sole responsibility to only operate this radio in legally acceptable frequency space and within legally mandated power limitations. Any exceptions to this are strictly prohibited and unauthorized by Texas Instruments unless user has obtained appropriate experimental/development licenses from local regulatory authorities, which is responsibility of user including its acceptable authorization.

### For EVMs annotated as FCC – FEDERAL COMMUNICATIONS COMMISSION Part 15 Compliant

#### Caution

This device complies with part 15 of the FCC Rules. Operation is subject to the following two conditions: (1) This device may not cause harmful interference, and (2) this device must accept any interference received, including interference that may cause undesired operation.

Changes or modifications not expressly approved by the party responsible for compliance could void the user's authority to operate the equipment.

### FCC Interference Statement for Class A EVM devices

This equipment has been tested and found to comply with the limits for a Class A digital device, pursuant to part 15 of the FCC Rules. These limits are designed to provide reasonable protection against harmful interference when the equipment is operated in a commercial environment. This equipment generates, uses, and can radiate radio frequency energy and, if not installed and used in accordance with the instruction manual, may cause harmful interference to radio communications. Operation of this equipment in a residential area is likely to cause harmful interference in which case the user will be required to correct the interference at his own expense.



### **FCC Interference Statement for Class B EVM devices**

This equipment has been tested and found to comply with the limits for a Class B digital device, pursuant to part 15 of the FCC Rules. These limits are designed to provide reasonable protection against harmful interference in a residential installation. This equipment generates, uses and can radiate radio frequency energy and, if not installed and used in accordance with the instructions, may cause harmful interference to radio communications. However, there is no guarantee that interference will not occur in a particular installation. If this equipment does cause harmful interference to radio or television reception, which can be determined by turning the equipment off and on, the user is encouraged to try to correct the interference by one or more of the following measures:

- Reorient or relocate the receiving antenna.
- Increase the separation between the equipment and receiver.
- Connect the equipment into an outlet on a circuit different from that to which the receiver is connected.
- Consult the dealer or an experienced radio/TV technician for help.

### **For EVMs annotated as IC – INDUSTRY CANADA Compliant**

This Class A or B digital apparatus complies with Canadian ICES-003.

Changes or modifications not expressly approved by the party responsible for compliance could void the user's authority to operate the equipment.

### **Concerning EVMs including radio transmitters**

This device complies with Industry Canada licence-exempt RSS standard(s). Operation is subject to the following two conditions: (1) this device may not cause interference, and (2) this device must accept any interference, including interference that may cause undesired operation of the device.

### **Concerning EVMs including detachable antennas**

Under Industry Canada regulations, this radio transmitter may only operate using an antenna of a type and maximum (or lesser) gain approved for the transmitter by Industry Canada. To reduce potential radio interference to other users, the antenna type and its gain should be so chosen that the equivalent isotropically radiated power (e.i.r.p.) is not more than that necessary for successful communication.

This radio transmitter has been approved by Industry Canada to operate with the antenna types listed in the user guide with the maximum permissible gain and required antenna impedance for each antenna type indicated. Antenna types not included in this list, having a gain greater than the maximum gain indicated for that type, are strictly prohibited for use with this device.

Cet appareil numérique de la classe A ou B est conforme à la norme NMB-003 du Canada.

Les changements ou les modifications pas expressément approuvés par la partie responsable de la conformité ont pu vider l'autorité de l'utilisateur pour actionner l'équipement.

### **Concernant les EVMs avec appareils radio**

Le présent appareil est conforme aux CNR d'Industrie Canada applicables aux appareils radio exempts de licence. L'exploitation est autorisée aux deux conditions suivantes : (1) l'appareil ne doit pas produire de brouillage, et (2) l'utilisateur de l'appareil doit accepter tout brouillage radioélectrique subi, même si le brouillage est susceptible d'en compromettre le fonctionnement.

### **Concernant les EVMs avec antennes détachables**

Conformément à la réglementation d'Industrie Canada, le présent émetteur radio peut fonctionner avec une antenne d'un type et d'un gain maximal (ou inférieur) approuvé pour l'émetteur par Industrie Canada. Dans le but de réduire les risques de brouillage radioélectrique à l'intention des autres utilisateurs, il faut choisir le type d'antenne et son gain de sorte que la puissance isotrope rayonnée équivalente (p.i.r.e.) ne dépasse pas l'intensité nécessaire à l'établissement d'une communication satisfaisante.

Le présent émetteur radio a été approuvé par Industrie Canada pour fonctionner avec les types d'antenne énumérés dans le manuel d'usage et ayant un gain admissible maximal et l'impédance requise pour chaque type d'antenne. Les types d'antenne non inclus dans cette liste, ou dont le gain est supérieur au gain maximal indiqué, sont strictement interdits pour l'exploitation de l'émetteur.

## **【Important Notice for Users of this Product in Japan】**

**This development kit is NOT certified as Confirming to Technical Regulations of Radio Law of Japan**

If you use this product in Japan, you are required by Radio Law of Japan to follow the instructions below with respect to this product:

1. Use this product in a shielded room or any other test facility as defined in the notification #173 issued by Ministry of Internal Affairs and Communications on March 28, 2006, based on Sub-section 1.1 of Article 6 of the Ministry's Rule for Enforcement of Radio Law of Japan,
2. Use this product only after you obtained the license of Test Radio Station as provided in Radio Law of Japan with respect to this product, or
3. Use of this product only after you obtained the Technical Regulations Conformity Certification as provided in Radio Law of Japan with respect to this product. Also, please do not transfer this product, unless you give the same notice above to the transferee. Please note that if you could not follow the instructions above, you will be subject to penalties of Radio Law of Japan.

**Texas Instruments Japan Limited**  
**(address) 24-1, Nishi-Shinjuku 6 chome, Shinjuku-ku, Tokyo, Japan**

<http://www.tij.co.jp>

### **【ご使用にあたっての注】**

本開発キットは技術基準適合証明を受けておりません。

本製品のご使用に際しては、電波法遵守のため、以下のいずれかの措置を取っていただく必要がありますのでご注意ください。

1. 電波法施行規則第6条第1項第1号に基づく平成18年3月28日総務省告示第173号で定められた電波暗室等の試験設備でご使用いただく。
2. 実験局の免許を取得後ご使用いただく。
3. 技術基準適合証明を取得後ご使用いただく。

なお、本製品は、上記の「ご使用にあたっての注意」を譲渡先、移転先に通知しない限り、譲渡、移転できないものとします。

上記を遵守頂けない場合は、電波法の罰則が適用される可能性があることをご留意ください。

日本テキサス・インスツルメンツ株式会社  
東京都新宿区西新宿6丁目24番1号  
西新宿三井ビル

<http://www.tij.co.jp>

## **EVALUATION BOARD/KIT/MODULE (EVM) WARNINGS, RESTRICTIONS AND DISCLAIMERS**

**For Feasibility Evaluation Only, in Laboratory/Development Environments.** Unless otherwise indicated, this EVM is not a finished electrical equipment and not intended for consumer use. It is intended solely for use for preliminary feasibility evaluation in laboratory/development environments by technically qualified electronics experts who are familiar with the dangers and application risks associated with handling electrical mechanical components, systems and subsystems. It should not be used as all or part of a finished end product.

Your Sole Responsibility and Risk. You acknowledge, represent and agree that:

1. You have unique knowledge concerning Federal, State and local regulatory requirements (including but not limited to Food and Drug Administration regulations, if applicable) which relate to your products and which relate to your use (and/or that of your employees, affiliates, contractors or designees) of the EVM for evaluation, testing and other purposes.
2. You have full and exclusive responsibility to assure the safety and compliance of your products with all such laws and other applicable regulatory requirements, and also to assure the safety of any activities to be conducted by you and/or your employees, affiliates, contractors or designees, using the EVM. Further, you are responsible to assure that any interfaces (electronic and/or mechanical) between the EVM and any human body are designed with suitable isolation and means to safely limit accessible leakage currents to minimize the risk of electrical shock hazard.
3. You will employ reasonable safeguards to ensure that your use of the EVM will not result in any property damage, injury or death, even if the EVM should fail to perform as described or expected.
4. You will take care of proper disposal and recycling of the EVM's electronic components and packing materials.

**Certain Instructions.** It is important to operate this EVM within TI's recommended specifications and environmental considerations per the user guidelines. Exceeding the specified EVM ratings (including but not limited to input and output voltage, current, power, and environmental ranges) may cause property damage, personal injury or death. If there are questions concerning these ratings please contact a TI field representative prior to connecting interface electronics including input power and intended loads. Any loads applied outside of the specified output range may result in unintended and/or inaccurate operation and/or possible permanent damage to the EVM and/or interface electronics. Please consult the EVM User's Guide prior to connecting any load to the EVM output. If there is uncertainty as to the load specification, please contact a TI field representative. During normal operation, some circuit components may have case temperatures greater than 60°C as long as the input and output are maintained at a normal ambient operating temperature. These components include but are not limited to linear regulators, switching transistors, pass transistors, and current sense resistors which can be identified using the EVM schematic located in the EVM User's Guide. When placing measurement probes near these devices during normal operation, please be aware that these devices may be very warm to the touch. As with all electronic evaluation tools, only qualified personnel knowledgeable in electronic measurement and diagnostics normally found in development environments should use these EVMs.

**Agreement to Defend, Indemnify and Hold Harmless.** You agree to defend, indemnify and hold TI, its licensors and their representatives harmless from and against any and all claims, damages, losses, expenses, costs and liabilities (collectively, "Claims") arising out of or in connection with any use of the EVM that is not in accordance with the terms of the agreement. This obligation shall apply whether Claims arise under law of tort or contract or any other legal theory, and even if the EVM fails to perform as described or expected.

**Safety-Critical or Life-Critical Applications.** If you intend to evaluate the components for possible use in safety critical applications (such as life support) where a failure of the TI product would reasonably be expected to cause severe personal injury or death, such as devices which are classified as FDA Class III or similar classification, then you must specifically notify TI of such intent and enter into a separate Assurance and Indemnity Agreement.

Mailing Address: Texas Instruments, Post Office Box 655303, Dallas, Texas 75265  
Copyright © 2012, Texas Instruments Incorporated

## IMPORTANT NOTICE

Texas Instruments Incorporated and its subsidiaries (TI) reserve the right to make corrections, enhancements, improvements and other changes to its semiconductor products and services per JESD46, latest issue, and to discontinue any product or service per JESD48, latest issue. Buyers should obtain the latest relevant information before placing orders and should verify that such information is current and complete. All semiconductor products (also referred to herein as "components") are sold subject to TI's terms and conditions of sale supplied at the time of order acknowledgment.

TI warrants performance of its components to the specifications applicable at the time of sale, in accordance with the warranty in TI's terms and conditions of sale of semiconductor products. Testing and other quality control techniques are used to the extent TI deems necessary to support this warranty. Except where mandated by applicable law, testing of all parameters of each component is not necessarily performed.

TI assumes no liability for applications assistance or the design of Buyers' products. Buyers are responsible for their products and applications using TI components. To minimize the risks associated with Buyers' products and applications, Buyers should provide adequate design and operating safeguards.

TI does not warrant or represent that any license, either express or implied, is granted under any patent right, copyright, mask work right, or other intellectual property right relating to any combination, machine, or process in which TI components or services are used. Information published by TI regarding third-party products or services does not constitute a license to use such products or services or a warranty or endorsement thereof. Use of such information may require a license from a third party under the patents or other intellectual property of the third party, or a license from TI under the patents or other intellectual property of TI.

Reproduction of significant portions of TI information in TI data books or data sheets is permissible only if reproduction is without alteration and is accompanied by all associated warranties, conditions, limitations, and notices. TI is not responsible or liable for such altered documentation. Information of third parties may be subject to additional restrictions.

Resale of TI components or services with statements different from or beyond the parameters stated by TI for that component or service voids all express and any implied warranties for the associated TI component or service and is an unfair and deceptive business practice. TI is not responsible or liable for any such statements.

Buyer acknowledges and agrees that it is solely responsible for compliance with all legal, regulatory and safety-related requirements concerning its products, and any use of TI components in its applications, notwithstanding any applications-related information or support that may be provided by TI. Buyer represents and agrees that it has all the necessary expertise to create and implement safeguards which anticipate dangerous consequences of failures, monitor failures and their consequences, lessen the likelihood of failures that might cause harm and take appropriate remedial actions. Buyer will fully indemnify TI and its representatives against any damages arising out of the use of any TI components in safety-critical applications.

In some cases, TI components may be promoted specifically to facilitate safety-related applications. With such components, TI's goal is to help enable customers to design and create their own end-product solutions that meet applicable functional safety standards and requirements. Nonetheless, such components are subject to these terms.

No TI components are authorized for use in FDA Class III (or similar life-critical medical equipment) unless authorized officers of the parties have executed a special agreement specifically governing such use.

Only those TI components which TI has specifically designated as military grade or "enhanced plastic" are designed and intended for use in military/aerospace applications or environments. Buyer acknowledges and agrees that any military or aerospace use of TI components which have **not** been so designated is solely at the Buyer's risk, and that Buyer is solely responsible for compliance with all legal and regulatory requirements in connection with such use.

TI has specifically designated certain components as meeting ISO/TS16949 requirements, mainly for automotive use. In any case of use of non-designated products, TI will not be responsible for any failure to meet ISO/TS16949.

### Products

Audio	<a href="http://www.ti.com/audio">www.ti.com/audio</a>
Amplifiers	<a href="http://amplifier.ti.com">amplifier.ti.com</a>
Data Converters	<a href="http://dataconverter.ti.com">dataconverter.ti.com</a>
DLP® Products	<a href="http://www.dlp.com">www.dlp.com</a>
DSP	<a href="http://dsp.ti.com">dsp.ti.com</a>
Clocks and Timers	<a href="http://www.ti.com/clocks">www.ti.com/clocks</a>
Interface	<a href="http://interface.ti.com">interface.ti.com</a>
Logic	<a href="http://logic.ti.com">logic.ti.com</a>
Power Mgmt	<a href="http://power.ti.com">power.ti.com</a>
Microcontrollers	<a href="http://microcontroller.ti.com">microcontroller.ti.com</a>
RFID	<a href="http://www.ti-rfid.com">www.ti-rfid.com</a>
OMAP Applications Processors	<a href="http://www.ti.com/omap">www.ti.com/omap</a>
Wireless Connectivity	<a href="http://www.ti.com/wirelessconnectivity">www.ti.com/wirelessconnectivity</a>

### Applications

Automotive and Transportation	<a href="http://www.ti.com/automotive">www.ti.com/automotive</a>
Communications and Telecom	<a href="http://www.ti.com/communications">www.ti.com/communications</a>
Computers and Peripherals	<a href="http://www.ti.com/computers">www.ti.com/computers</a>
Consumer Electronics	<a href="http://www.ti.com/consumer-apps">www.ti.com/consumer-apps</a>
Energy and Lighting	<a href="http://www.ti.com/energy">www.ti.com/energy</a>
Industrial	<a href="http://www.ti.com/industrial">www.ti.com/industrial</a>
Medical	<a href="http://www.ti.com/medical">www.ti.com/medical</a>
Security	<a href="http://www.ti.com/security">www.ti.com/security</a>
Space, Avionics and Defense	<a href="http://www.ti.com/space-avionics-defense">www.ti.com/space-avionics-defense</a>
Video and Imaging	<a href="http://www.ti.com/video">www.ti.com/video</a>

### TI E2E Community

[e2e.ti.com](http://e2e.ti.com)