

# HEAVY DUTY ENCLOSURES

## 7710 Series Hinged Wall Mount Enclosures

UNIVERSAL ENCLOSURES

HAND HELD CASES

HEAVY DUTY ENCLOSURES

DIN RAIL BOXES

INTERFACE SUPPORTS

CONTROL STATIONS

DIECAST & METAL BOXES

DESKTOP & INSTRUMENT CASES

POTTING BOXES

19" ENCLOSURES

19" CABINETS

DEVELOPMENT BOARDS

CUSTOM SIZED ENCLOSURES

CUSTOM SERVICES

Wall mounted enclosures with a transparent and hinged polycarbonate cover. Designed to house electronic applications.

- Moulded in high quality PC/ABS
- Suitable for high temperatures
- Protects controls and components indoors or outdoors
- With two detachable hinges for quick access
- Fastening pillars and guide grooves for vertical and horizontal PCB mounting
- Hinges can be left or right mounted
- DIN rail mountable
- EPDM gasket for IP65 seal pre-installed
- Available in five sizes

### SPECIFICATION

Materials	Box: Polycarbonate ABS UL94-V0 Lid: Polycarbonate UL94-V0
Operating Temperature	Heat resistant up to 120°C
Ingress protection class	IP65
Standard colours	Light grey, similar to RAL 7038, Transparent lid
Standard unit includes	Box, lid, hinges, catch, fixing screws and neoprene gasket



PART NO.	LENGTH	WIDTH	HEIGHT
CHD771001	161mm	166mm	93mm
CHD771002	161mm	166mm	121mm
CHD771003	185mm	213mm	104.5mm
CHD771004	217mm	256mm	132.5mm
CHD771005	281mm	296mm	158mm

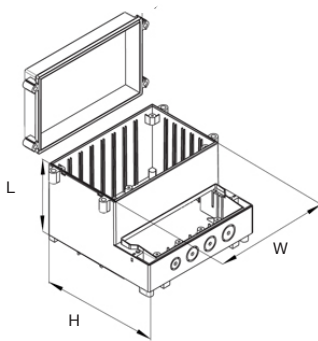

## Wall Mounting Kit

PART NO.	DESCRIPTION
CHD7700MK	Mounting Brackets