

New – Pyroelectric Infrared Detectors and Thermopile Sensors in SMD

Excelitas' newest SMD pyroelectric infrared detectors and SMD thermopiles are taking infrared sensing innovation to a whole new level, enabling automated, high-volume production for major sensing applications from intrusion alarm systems, to energy-saving, motion-activated light switches, and even the latest high-tech consumer devices.

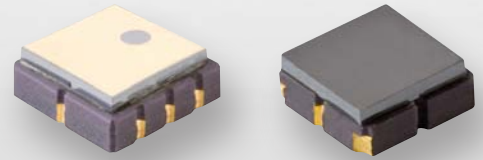

Enabling Automated, High-Volume Production for Cutting-edge IR Sensing Applications

Excelitas Technologies is pleased to introduce its newest surface-mount design (SMD) Pyroelectric Infrared Detectors and Thermopile Sensors. To meet your design needs, our new SMD designs are available in both digital and analog models.

New SMD Pyroelectric Detectors. DigiPyro® is the one and only truly digital Family of Pyroelectric IR Detectors. With a legacy of continuing innovations in infrared sensing technology, and a focus on smaller and smarter digital solutions, Excelitas is now introducing a brand new SMD package to its dual-element DigiPyro® range. The new PYD 5790 is a dual-element pyro in a ceramic-type SMD package that is 5x5 mm² with a height of only 1.8 mm, the smallest of its kind on the market. As a basis for comparison, dual-element DigiPyro® models in TO-type housings are 4.2 mm in height. Excelitas is also offering its traditional, analog dual-element pyroelectric model in an SMD housing, the PYD 5190.

New SMD Thermopile Detectors. DigiPile™ is the revolutionary, digital Family of Thermopile Sensors, designed specifically for non-contact temperature measurement. Joining DigiPile™ models in TO-46 and TO-5 metal housings, Excelitas is introducing the TPIS 1S 1253, its newest DigiPile™ in a ceramic-type SMD package. It is 5x5 mm² with a height of only 1.8 mm, the smallest of its kind on the market. Excelitas is also offering its traditional, analog thermopile detector in an SMD housing, the TPiD 1S 0122. The TPiD 1S 0122 thermopile is equipped with a 100 kΩ thermistor that can serve as a temperature reference for thermopile temperature compensation to further improve accuracy. Excelitas' SMD Thermopile detectors deliver excellent thermal shock performance.

Advantages

- Surface-mount devices (SMD) well-suited for high-volume production of components on PCBs.
- Allows for automated pick-and-place and solder reflow
- Very small size and compact design of new SMD components, as compared to traditional TO-type metal housings
- SMD housings available for both pyroelectric infrared detectors and thermopiles

Applications

- Motion and Presence Detection — For Secure Homes
- Motion Sensing — Automatic Light Switching
- Presence Detection — for Display Control in Smart Consumer Electronic Devices
- Energy-Conserving Home Appliances — e.g. microwaves, IH cooktops
- Energy-conserving HVAC
- Thermometry
- Non-contact Temperature Sensing
- Gesture Recognition

Pyroelectric Detectors and Sensors in SMD



DigiPyro® – PYD 5790

Digital Pyroelectric Infrared Sensor, DigiPyro® Dual-element, In SMD

Parameter	Symbol	DigiPyro® PYD 5790	Unit	Remarks
Responsivity, min.	R _{min}	7.5	kV/W	f = 1 Hz
Responsivity, typ.	R	10	kV/W	f = 1 Hz
Match, max.	M _{max}	10	%	
Noise, max.	N _{max}	150	μV _{pp}	0.4 - 10 Hz, 20 °C
Noise, typ.	N _{typ}	60	μV _{pp}	0.4 - 10 Hz, 20 °C
Field of View, vertical	FoV	79° + 33°		unobstructed
Field of View, horizontal	FoV	133°		unobstructed
Operating Voltage	V _{DD}	2.7 - 3.6	V	
Supply Current	I _{DD}	10	μA	V _{DD} =3,3V
Supply Current	I _{DDmax}	15	μA	V _{DD} =3,3V
Digital Data				
Serial Interface Update Time	t _{REP min}	2	ms	speed / interrupt
ADC Resolution		14	Bits	
Output Data Format		2 x 14	Bits	MSB first
ADC Sensitivity		6-7	μV/count	
ADC Output Offset		6500 - 9800	counts	
ADC Output Offset, typ.		8192	counts	
Temperature Reference				
Gain (temperature)		80	Counts / K	-20 °C to +80 °C
Linearity		-5 - +5	%	-20 °C to +80 °C
Filter				
Digital Filter Cut Off		10	Hz	

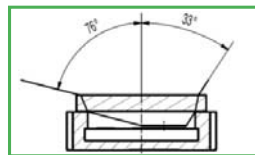
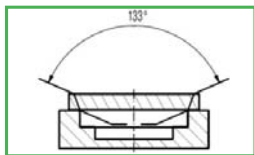
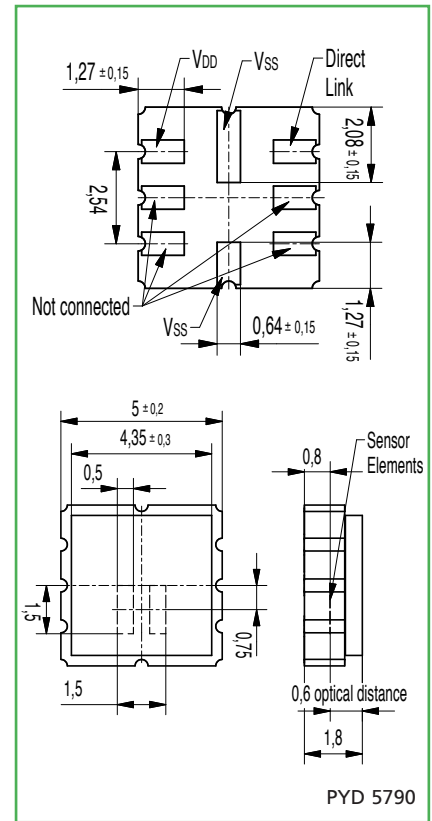

Fig 2 Field of View: Horizontal

Fig 3 Field of View: Vertical

Pyroelectric Infrared Detector – PYD 5190

Pyroelectric Infrared Detector, Analog Dual-element, In SMD

Parameter	Symbol	PYD 5190	Unit	Remarks
Responsivity, min.	R _{min}	6.5	kV/W	f = 1 Hz
Responsivity, typ.	R	8.5	kV/W	f = 1 Hz
Match, max.	M _{max}	10	%	
Noise, Max.	N _{max}	150	μV _{pp}	0.4 - 10 Hz, 20 °C
Noise, Typ.	N _{typ}	60	μV _{pp}	0.4 - 10 Hz, 20 °C
Source Voltage		0.2 - 2.5	V	47 kΩ / 20 °C / 5 V
Field of View, vertical	FoV	76° + 33°		unobstructed
Field of View, horizontal	FoV	133°		unobstructed
Operating voltage		2.0 - 12 V	V	47 kΩ / 20 °C

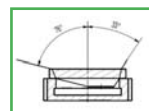
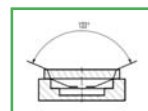
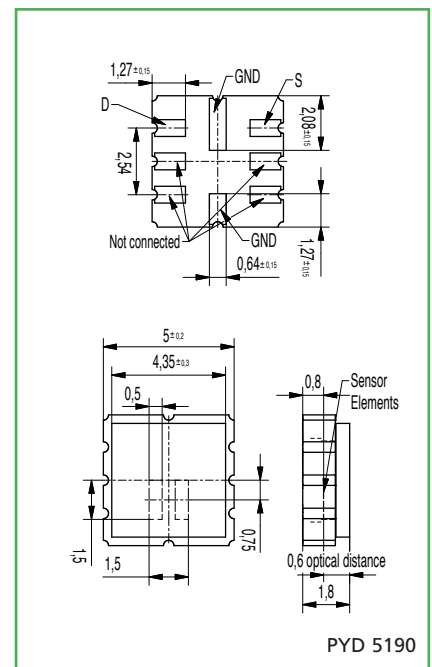

Fig 4 Field of View: Horizontal

Fig 5 Field of View: Vertical



Thermopile Detectors and Sensors in SMD



DigiPile™ – TPiS 1S 1253 Digital Thermopile Sensor, DigiPile™ in SMD

Parameter	Symbol	Min	Typ	Max	Unit	Remarks / Conditions
Operating Conditions						
Operating Voltage	V _{DD}	2.4	3.3	3.6	V	
Supply Current	I _{DD}	-	11	15	μA	V _{DD} = 3.3 V
Operating Temperature	T _O	-20		70	°C	The electrical parameters may vary from specified values in accordance with their temperature dependence.
Storage Temperature	T _S	-40		100	°C	Avoid storage in humid environment.
Thermopile Characteristics						
Sensitive Area	A		0.26		mm ²	Absorber area = 0.51 x 0.51 mm ²
Sensitivity	Δcounts / ΔT		200		counts/K	T _{obj} = 313K = 60°C, T _{amb} = 298K = 25°C
Noise			8		counts	T _{obj} = 313K (=60°C), T _{amb} = 298K (=25°C)
Time Constant	t		45		ms	
Ambient Temperature Sensor Characteristics						
Sensitivity of T _{amb}			90		counts/K	Linear for T _{amb} from 0°C to 90°C
Count @ T _{amb} = 25°C			7800		counts	
Optical Characteristics						
Field of View			~120		Degree	At 50% intensity points
Optical Axis			0	+/- 10	Degree	
Electrical Characteristics						
ADC Resolution T _{obj}			17		Bits	Max Count = 2 ¹⁷
ADC Resolution T _{amb}			14		Bits	Max Count = 2 ¹⁴
ADC Sensitivity of T _{obj}		0.7	0.8	0.9	μV/count	
ADC Offset T _{obj}			64500		counts	

Table 3

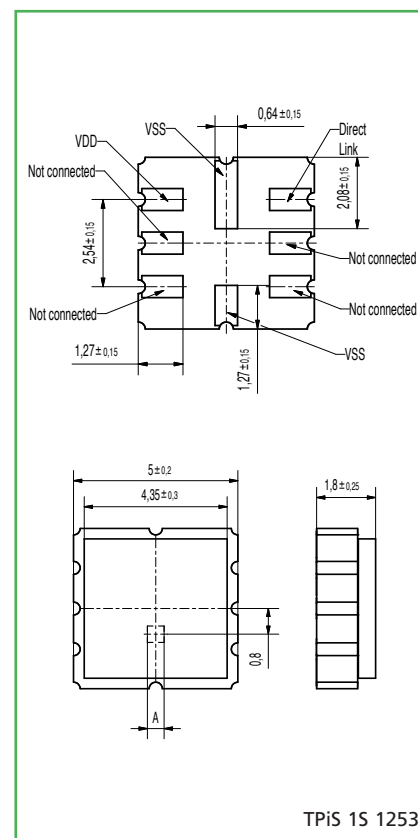

TPiS 1S 1253

Figure 7

Thermopile Detector – TPiD 1S 0122 Thermopile Detector, Analog, in SMD

Parameter	Symbol	TPiD 1S 0122	Unit	Remarks
Sensitive Area	A	0.2	mm ²	Absorber area
Thermopile Resistance	R _{TP}	85 - 135	kΩ	25 °C
Responsivity	R _{TP}	77	V/W	500 K / 1 Hz / without IR filter
Sensitivity (T _{det} 25 °C / T _{obj} 100 °C)	S ₁₀₀	150	μV/K	0.4 - 10 Hz, 20 °C
Time Constant	t	15	ms	0.4 - 10 Hz, 20 °C
Noise voltage	V _N	42	nV/√Hz	25 °C
Specific Detectivity	D*	0.8	10 ⁸ cm ² /Hz/W	25 °C
Temp. Coefficient of Resistance	TC _{RTP}	0.03	%/K	
Temp. Coefficient of Responsivity	TC _R	-0.05	%/K	
Field of View	FoV	115	Degrees	At 50% intensity points
Thermistor Resistance	R ₂₅	100	kΩ	47 kΩ / 20 °C
Thermistor BETA-value	β	4097	K	Defined at 25 °C / 100°C

Table 4

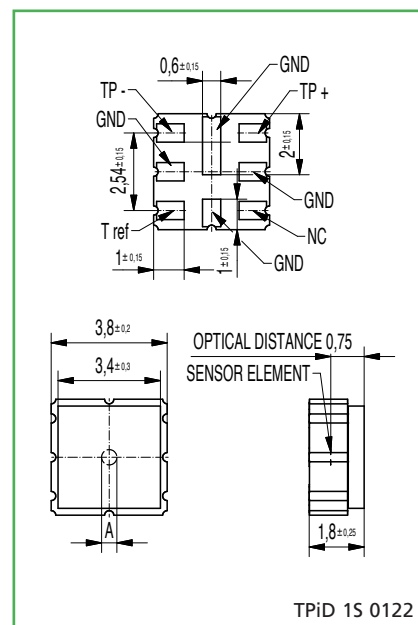

TPiD 1S 0122

Figure 8

New – Pyroelectric Infrared Detectors and Thermopile Sensors in SMD



About the DigiPyro® Family

DigiPyro® is the industry's one and only truly Digital Pyroelectric Infrared Detector Family.

Excelitas offers a complete range of DigiPyro® Pyroelectric Infrared Detectors in TO Metal Housings and now in very small SMD housings to facilitate high-volume, SMT-compatible production.

Traditional DigiPyro® detectors in TO-housings include Dual-element models, PYD 1788 and 1798; Four-element, PYQ 2898 and PYQ 5848; as well as “Smart” DigiPyro® models, PYD 1096 and PYQ 1098, with total motion electronics integration.

More additions to the innovative range of DigiPyro® detectors will be coming soon.

About the DigiPile™ Family

The DigiPile™ is a thermopile detector with digital output and highly-reliable digital design functionality.

The move from analog to digital has offered OEM designers a range of advantages including reduced PCB space requirements, improved EMI resistance, and the need for fewer additional components. Specifically the need for additional low-noise amplifiers is eliminated when using DigiPile™ thermopile detectors from Excelitas.

Excelitas offers a range of traditional TO metal housings for its DigiPile™ Family of digital thermopile detectors and detector options with built-in lens.

Excelitas now offers the DigiPile™ in very small SMD housings to facilitate high-volume, SMT-compatible production.

About Excelitas Technologies

Excelitas Technologies is a global technology leader focused on delivering innovative, customized solutions to meet the detection, lighting, and advanced electronic systems needs of OEM customers.

From safety and security applications to industrial, consumer, medical, analytical instrumentation, clinical diagnostics, and aerospace and defense applications, Excelitas Technologies is committed to enabling our customers' success in their end-markets.

Excelitas Technologies has approximately 3,000 employees in North America, Europe and Asia, serving customers across the world.

Excelitas Technologies
22001 Dumberry Road
Vaudreuil-Dorion, Quebec
Canada J7V 8P7
Telephone: (+1) 450.424.3300
Toll Free: (+1) 800.775.6786
Fax: (+1) 450.424.3345
detection.na@excelitas.com

**Excelitas Technologies
GmbH & Co. KG**
Wenzel-Jaksch-Str. 31
D-65199 Wiesbaden
Germany
Telephone: (+49) 611 492 430
Fax: (+49) 611 492 165
detection.europe@excelitas.com

Excelitas Technologies
47 Ayer Rajah Crescent #06-12
Singapore 139947
Telephone: (+65) 6775-2022
Fax: (+65) 6775-1008
detection.asia@excelitas.com

For a complete listing of our global offices, visit www.excelitas.com/Locations

© 2012 Excelitas Technologies Corp. All rights reserved. The Excelitas logo and design are registered trademarks of Excelitas Technologies Corp. All other trademarks not owned by Excelitas Technologies or its subsidiaries that are depicted herein are the property of their respective owners. Excelitas reserves the right to change this document at any time without notice and disclaims liability for editorial, pictorial or typographical errors.

EXCELITAS
TECHNOLOGIES