

Top View of Assembly

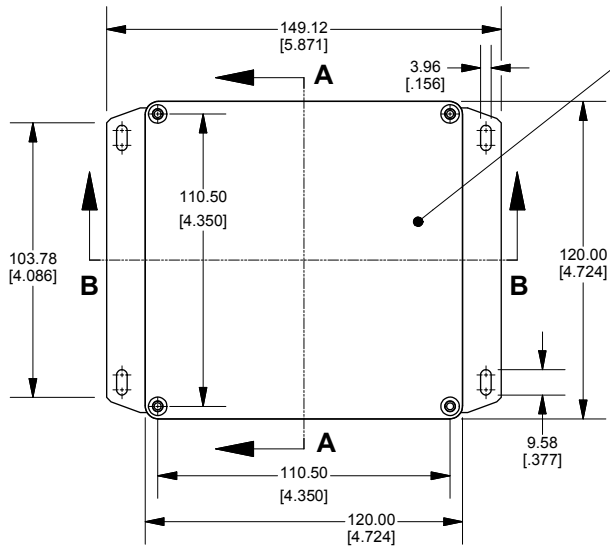

SECTION A-A End View of Assembly

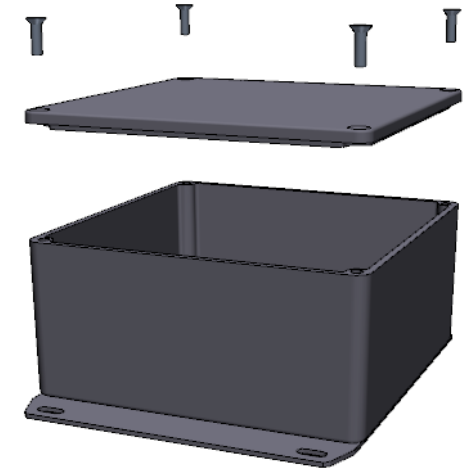
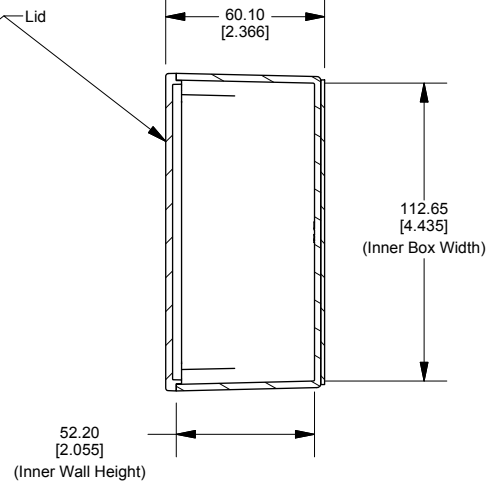

Top View Looking Inside Box

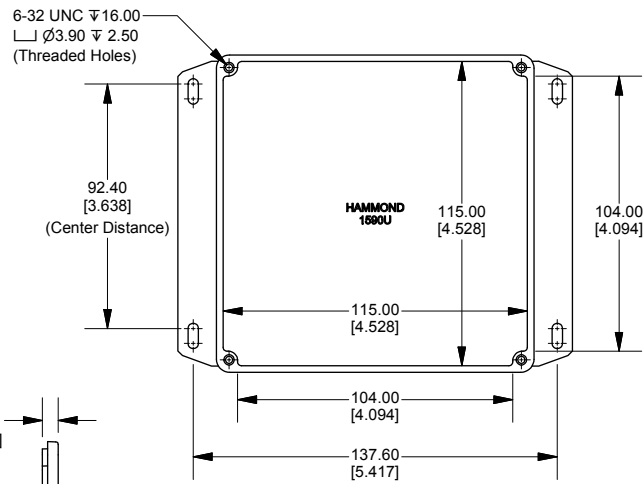

SECTION B-B Side View of Assembly

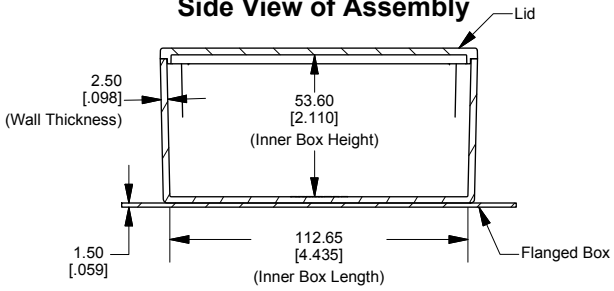

Lid

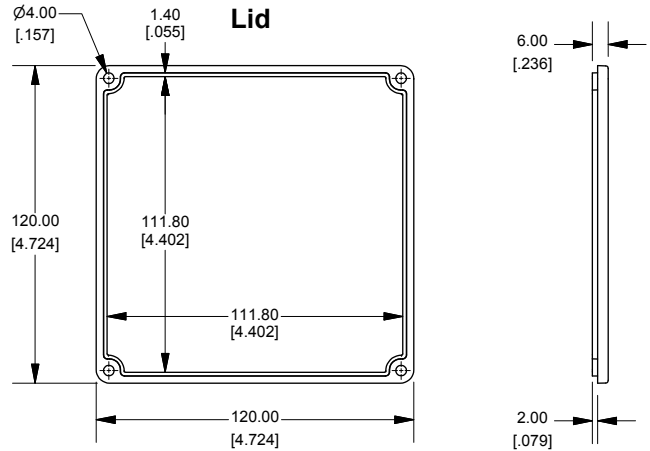

Enclosures can be Factory Modified (Milling, Drilling, Printing etc.)
 Contact Factory mjm@hammondmfg.com for quotes
 Solid models of this enclosure available in STEP or IGES.

NOTE	
Purchased assembly includes box, lid and 4 cover screws.	
Box and lid are made from Diecast Aluminum Alloy.	
Silicone Gasket supplied with liquid resistant enclosure.	
Bottom Flange is Welded.	

PART NUMBERS	
1590UF Enclosure	
Natural Finish Enclosure	1590UF
Black Textured Enclosure	1590UFBK
1590UF Liquid Resistant Enclosure (Silicone Gasket)	
Natural Finish Enclosure	1590WUF
Black Textured Enclosure	1590WUFBK
ACCESSORIES	
Recommended Torque: 75 ozf.in / 55 cN.m	
Liquid Resistant Cover Screws	
Stainless Steel Cover Screws (Pkg 100) [6-32 x 1/2" With O-Ring]	1590WMS100
Black Stainless Steel Cover Screws (Pkg 100) [6-32 x 1/2" With O-Ring]	1590WMS100BK
Standard Cover Screws	
Plated Cover Screws (Pkg 100) [6-32 x 1/2"]	1590MS100
Black Cover Screws (Pkg 100) [6-32 x 1/2"]	1590MS100BK

**HAMMOND
MANUFACTURING™**

1590UF

www.hammondmfg.com

Dimensions:
mm
[inches]