

Dimensions in mm

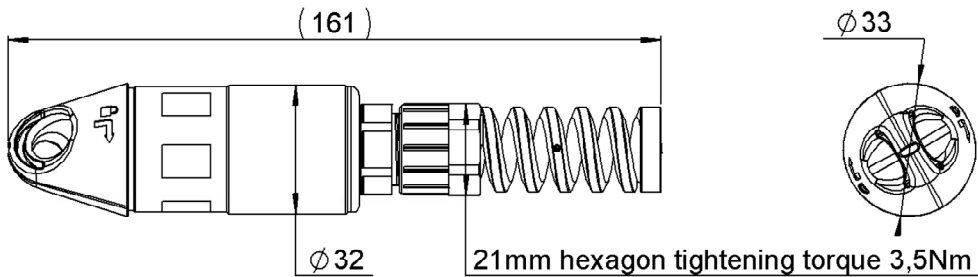
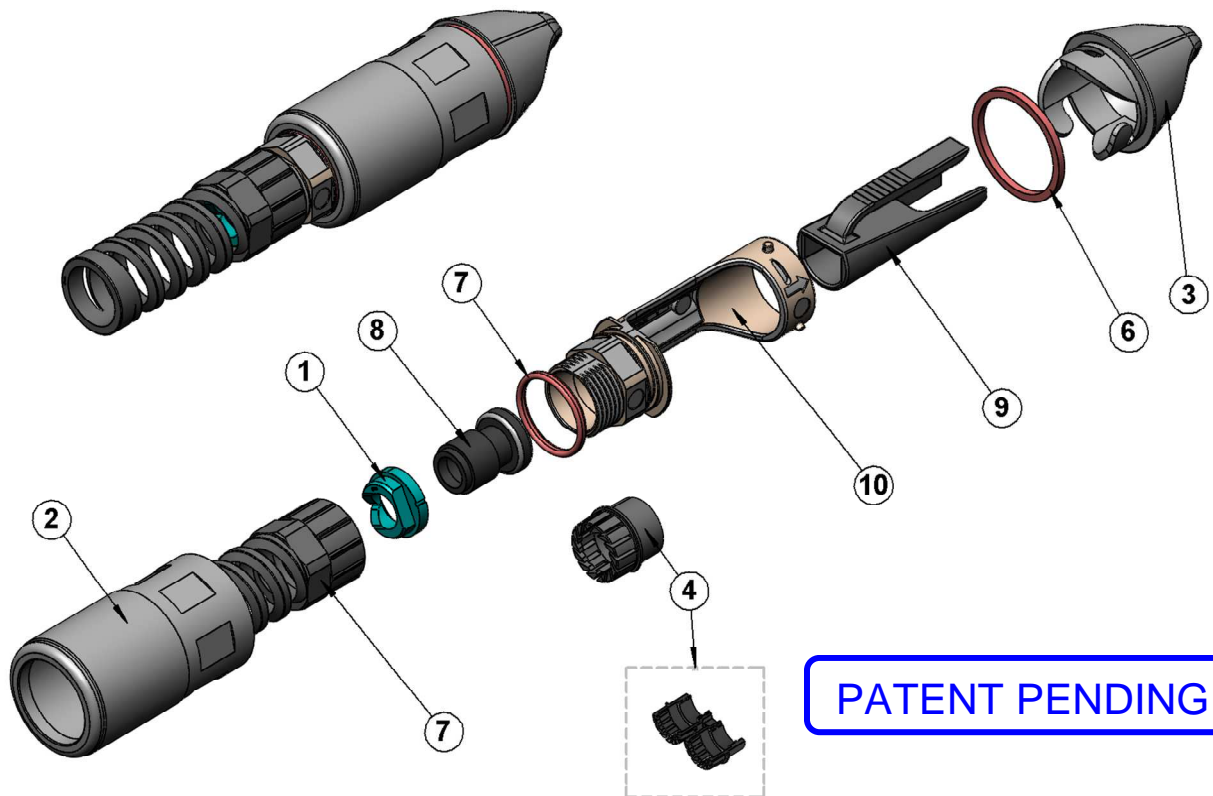

DESCRIPTION

REP	COMPONENT	MATERIALS	PLATING
1	TIGHTENING CONE	PA6.6	NA
2	COUPLING NUT	ALUMINIUM	NONE
3	PLUG PROTECTION CAP	PBT GF	NA
4	CLAMP NUT ELASTIC SHELL	PA6.6	NA
5	NUT TAIL OF PIG	PA6.6 GF	NA
6	SEALING CAP GASKET	SILICONE	NA
7	O-RING BODY GASKET	SILICONE	NA
8	CLAMP GASKET	NITRILE (NBR)	NA
9	UNLOCKING CLIP	PA6	NA
10	SHORT BODY	ZAMAK 5	NICKEL OVER COPPER

CREATION N°Project : EPC0812 Name : MR Date : 20/04/2011 Appr. : BD					RADIALL® 101, rue P. Hoffmann 93116 ROSNY/BOIS FRANCE Tel : (33) 0149353535 Fax : (33) 0148546363
	1112 A	Update	MR	BD	
	1040 A	Creation	MR	BD	
	Issue	Revisions	Name	Appr.	

Dimensions in mm

GENERAL CHARACTERISTICS (R2CT kit plug assembled on cable)

Mechanical Endurance Tensile load Vibration	200 mating cycles 200N at 3,5N.m tightening torque See validation plan
Environmental Protection Operating temperature	IP67 when mated with receptacle -40°C to +85°C

➤ RoHS compliant

➤ Types of cable assemblies to use :

Cable range diameter from 6.5mm to 7.1mm

VALIDATION PLAN

	Test	Sanction
MECHANICAL Visual and mechanical inspection Vibrations Bumps	All dimensions Sinusoidal vibrations according to IEC 60512-6-4 A IEC 60068-2-29 A	Compliant No electrical discontinuity No visual damage alter test No electrical discontinuity
ENVIRONMENTAL Sealing Salt Mist	IP65 according to IEC 60529 96H static (IEC 60068-2-11)	IP65 certification No damage or corrosion alter test

Packaging specification

- Unitary in plastic bag (180mm*130mm) with assembly note

CREATION N°Project : EPC0812 Name : MR Date : 20/04/2011 Appr. : BD				
	1112 A	Update	MR	BD
	1040 A	Creation	MR	BD
	Issue	Revisions	Name	Appr.

RADIALL®
 101, rue P. Hoffmann
 93116 ROSNY/BOIS
 FRANCE
 Tel : (33) 0149353535
 Fax : (33) 0148546363