

DWG. NO.

1321A00044

ISSUE F

REV.

C: REDRAWN-REV
NOTE 2
JC 12/7/88

D: REDRAWN TO CAD,
CHANGE NOTE 2
FROM ZINC II W/ YEL
CHROMATE FILM.
JTW MAY 11/98

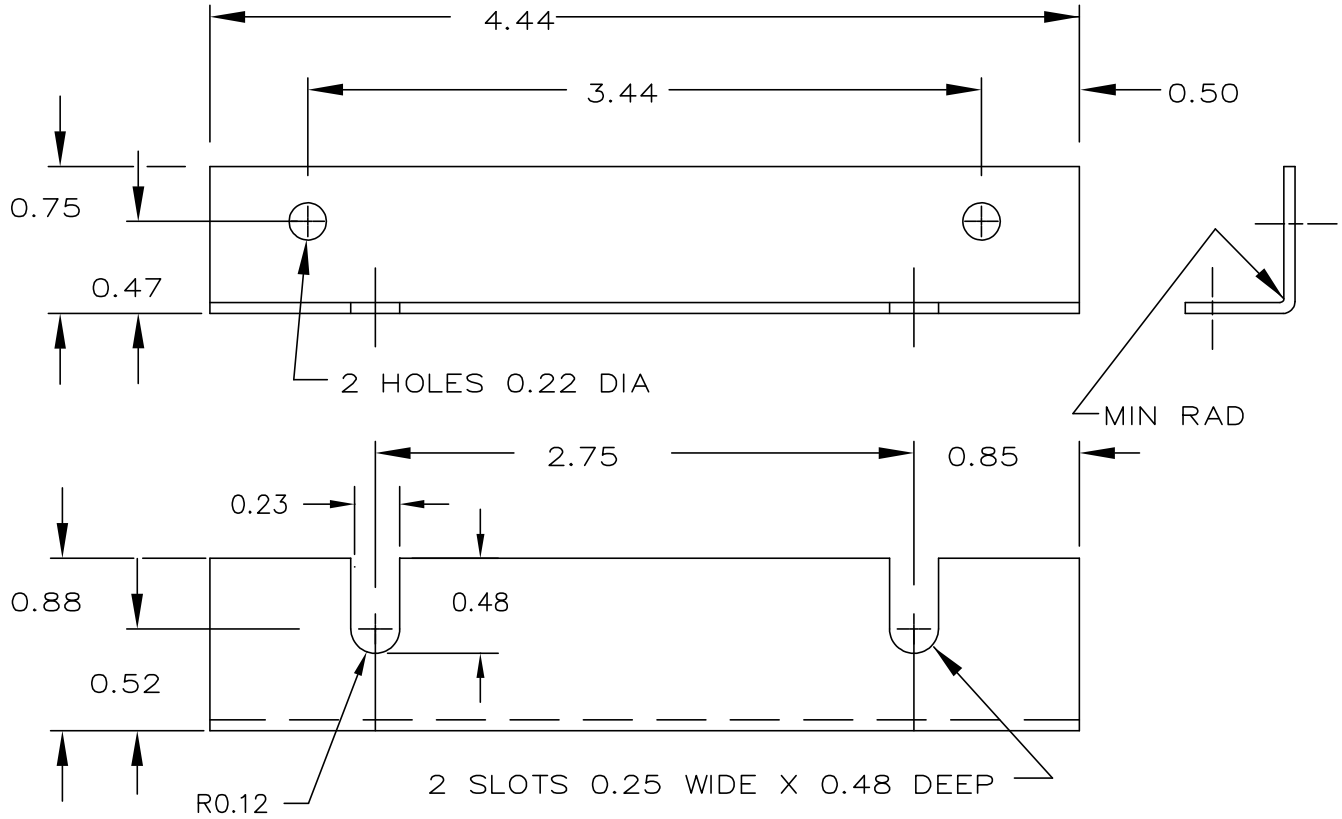

NOTES:

1. MATERIAL: 16 GA GALVANIZED STEEL ASTM A653
2. BREAK ALL SHARP CORNERS.

E: SEE ECO #1110450 JSW 5/1/02
F: SEE ECO #1112852 1/24/05 JSW
G: CHANGED 0.25 TO 0.23. 5/24/06 JTR
R



Instrument Transformers, Inc.
P.O. BOX 7180, Clearwater, FL, 33758

MATERIAL	TOLERANCE	DRAWN	DATE	TITLE	BRACKET - MODEL 7SH
NOTED	2 PL DEC.±0.01 3 PL DEC.±	JC	12/7/88		
SCALE FULL	SHEET 1 OF 1	PAGON	12/7/88	DWG. NO.	1321A00044
					ISSUE G