

### Top View of Assembly

### SECTION A-A End View of Assembly

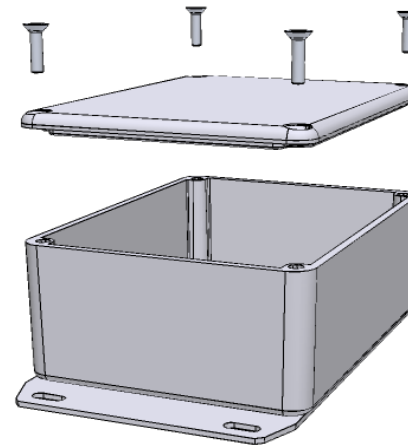
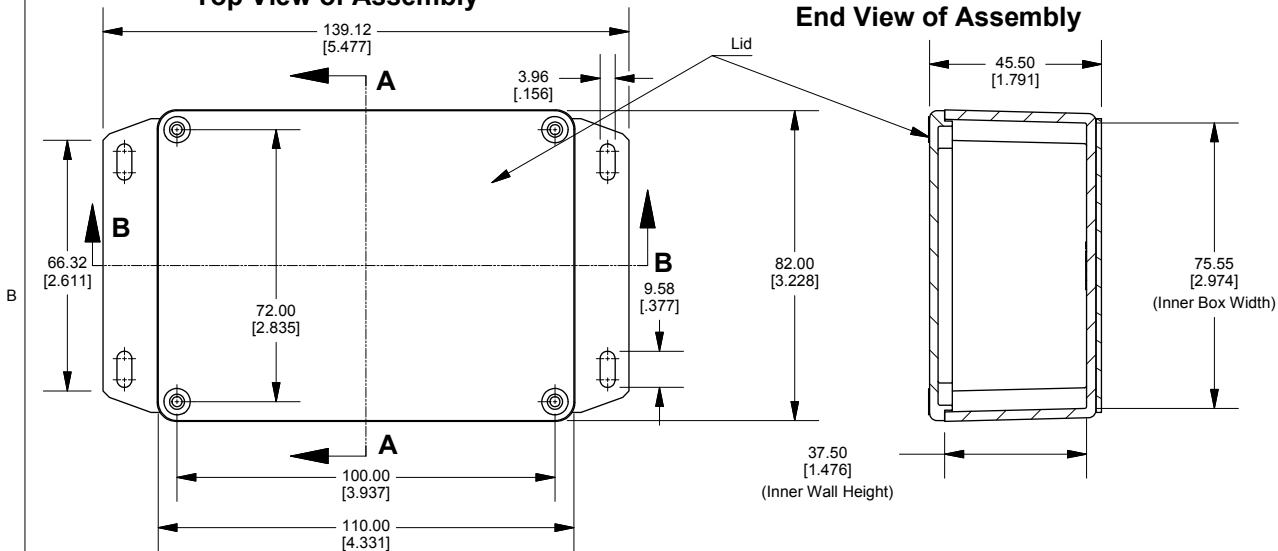

### SECTION B-B Side View of Assembly

### Top View Looking Inside Box

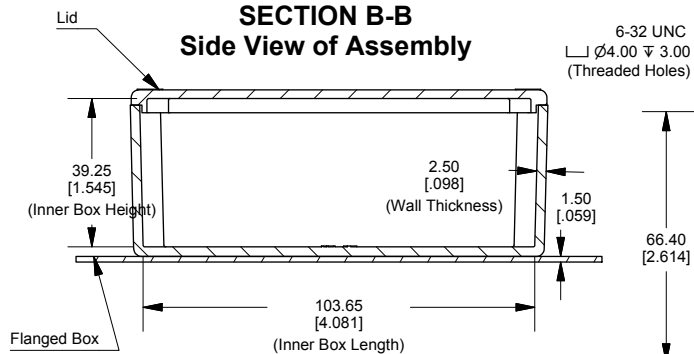

Enclosures can be Factory Modified ( Milling, Drilling, Printing etc.)  
 Contact Factory [mjm@hammondmfg.com](mailto:mjm@hammondmfg.com) for quotes  
 Solid models of this enclosure available in STEP or IGES.

#### NOTE

Purchased assembly includes box, lid and 4 cover screws.  
 Box and lid are made from Diecast Aluminum Alloy.  
 Silicone Gasket supplied with liquid resistant enclosure.  
 Bottom Flange is Welded.

#### PART NUMBERS

1590SF Enclosure	
Natural Finish Enclosure	1590SF
Black Textured Enclosure	1590SFBK
1590SF Liquid Resistant Enclosure (Silicone Gasket)	
Natural Finish Enclosure	1590WSF
Black Textured Enclosure	1590WSFBK

#### ACCESSORIES

Recommended Torque: 75 ozf.in / 55 cN.m

#### Liquid Resistant Cover Screws

Stainless Steel Cover Screws (Pkg 100) [6-32 x 1/2" With O-Ring]	1590WMS100
Black Stainless Steel Cover Screws (Pkg 100) [6-32 x 1/2" With O-Ring]	1590WMS100BK

#### Standard Cover Screws

Plated Cover Screws (Pkg 100) [6-32 x 1/2"]	1590MS100
Black Cover Screws (Pkg 100) [6-32 x 1/2"]	1590MS100BK

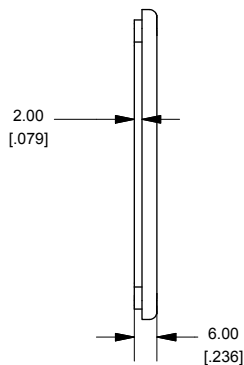
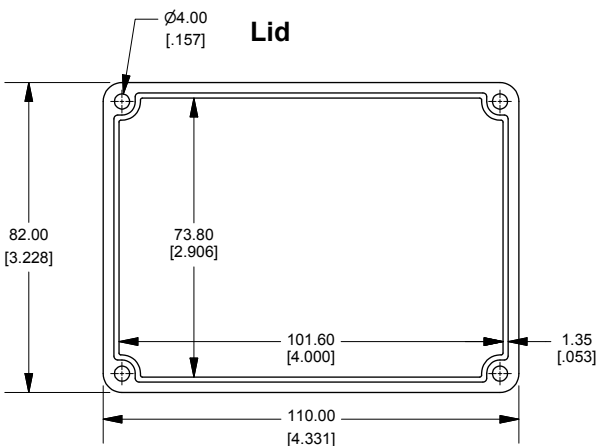

Dimensions:  
mm  
[inches]

**HAMMOND  
MANUFACTURING™**

**1590SF**

[www.hammondmfg.com](http://www.hammondmfg.com)