

ASSEMBLY

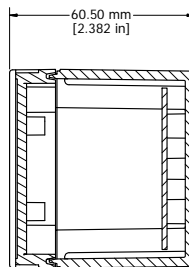

SECTION A-A

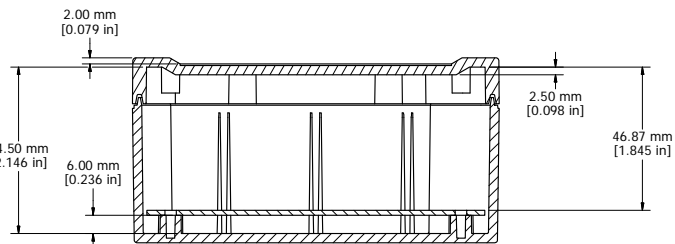
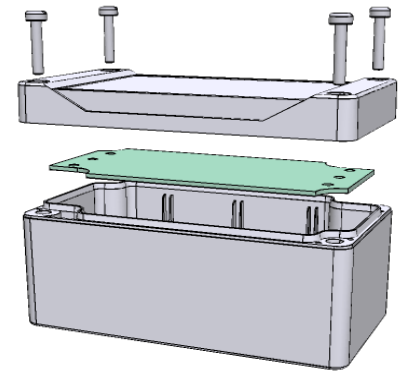

SECTION B-B

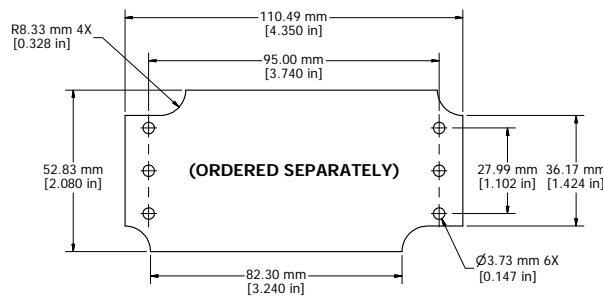

STEEL INNER PANEL

Polycarbonate Version Only
UL US LISTED
 File #E65324
 NEMA 4, 4X

Enclosures can be Factory Modified (Milling, Drilling, Printing etc.)
 Solid models of this enclosure available in STEP or IGES.
 Contact Factory mjm@hammondmfg.com

NOTE	
Purchased assembly includes box, styled lid, 4 cover screws, and preformed silicone gasket.	
General Purpose ABS version is not UL approved. (Matl UL94 - HB)	
Polycarbonate version is UL 508 approved. (Matl UL94 - V0 / 5VA @ 3mm)	
Recommended Cover screw torque -- 2.5 lbf-in (30 cN-m)	

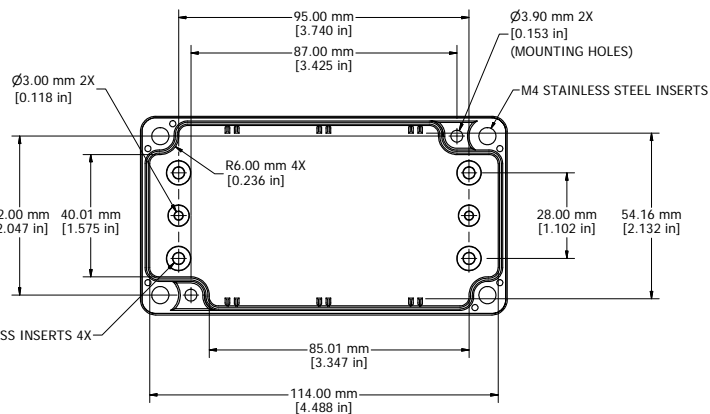

BOX - INSIDE

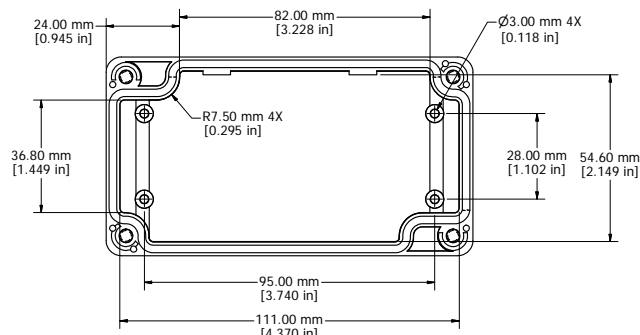

LID - INSIDE

1555D	
1555D Regular Enclosure	
General Purpose ABS RAL-7035	1555DGY
Polycarbonate RAL-7035	1555D2GY
ACCESSORIES	
Steel Inner Panels	1554CPL
Steel Panel / P.C. Board Machine Screw [M3 x 8mm Plated]	1591MM100
Steel Panel / P.C. Board Self Tapping Screw [#6 X 1/4" (6.4mm) Plated]	1598ATS100
Cover Screws (Pkg 4) [M4 X 20mm Stainless Steel]	SC1554

HAMMOND MANUFACTURING™
1555D
www.hammondmfg.com