

KAM

INSTRUCTION MANUAL

XY Laser Series

Pan & Tilt colour lasers

M A N U A L V E R S I O N 2 . 0
1 7 - 0 7 - 1 3

For the latest instruction manual updates and information on the entire Kam range visit:

www.kam.co.uk

Kam products are manufactured by: **Lamba plc**, Unit 1, Southfields Road, Dunstable, Bedfordshire, United Kingdom LU6 3EJ

Telephone: (+44) (0)1582 690600 • Fax: (+44) (0)1582 690400 • Email: mail@lambapl.com • Web: www.lambapl.com

If this product is ever no longer functional please take it to a recycling plant for environmentally friendly disposal.

Due to continuous product development, specifications and appearance are subject to change.

© Copyright Lamba plc 2013. E&OE.

Thank you for purchasing this Kam product, we are sure that it will serve you for many years to come.

To optimise the performance of this product, please read these operating instructions carefully to familiarise yourself with the basic operations of this unit. Please retain them for future reference. This unit has been tested at the factory before being shipped to you.

To prevent or reduce the risk of electrical shock or fire, do not expose the unit to rain or moisture. To prevent a fire hazard, do not expose the unit to any naked flame sources. Unplug this apparatus during lightning storms or if it is unlikely to be used for long periods of time.

When installing the unit, please ensure you leave enough space around the unit for ventilation. Slots and openings in the unit are provided for ventilation to ensure reliable operation of the product and to protect it from overheating. To prevent fire hazard, the openings should never be blocked or covered.

If the unit is powered by the mains, always handle the power cable by the plug. Never pull out the plug by pulling on the cable. Never touch the power cable when your hands are wet as this could cause an electric shock. Do not tie a knot in the cable. The power cable should be placed such that it is not likely to be stepped on. A damaged power cable can cause a fire or give you an electrical shock. Check the power cord periodically, if you ever find that it is damaged, replace it before using the unit again. Contact your retailer for a replacement.

The voltage of the available power supply differs according to country or region. Be sure that the power supply voltage of the area where this unit is to be used meets the required written on the unit.

The lightning flash symbol inside a triangle is to alert the user to the presence high voltage within the unit's enclosure that may be of sufficient power to constitute a risk of electrical shock to persons.

Caution: to prevent the risk of electric shock, do not attempt to open the unit. No user-serviceable parts inside. Refer all servicing to qualified service personnel.

The exclamation mark inside a triangle is intended to alert the user to the presence of important operating and maintenance instructions in the literature accompanying the appliance.

Select the installation location of your unit carefully. Avoid placing it in direct sunlight or locations subject to vibration and excessive dust. Do not use the unit where there are extremes in temperature (below 41°F / 5°C or exceeding 95°F / 35°C).

Unpacking and safety Please unpack your new product carefully. Your new product should reach you in perfect condition. Please check that no damage has occurred during transit. If any damage is found, do not operate your unit. Please contact the retailer you purchased it from immediately. If there is any damage to the mains cable do not use the device. Always disconnect the unit from the mains supply when carrying out any cleaning of the unit.

Manufacturer declarations



In compliance with the following requirements: **RoHS Directive (2002/95/EU)** and **WEEE Directive (2002/96/EU)**.
If this product is ever no longer functional please take it to a recycling plant for environmentally friendly disposal.

CE declaration of conformity

R&TTE Directive (1999/5/EU), EMC Directive (2004/108/EU), Low Voltage Directive (2006/95/EU).

The declarations are available on application from certification@lambapl.com

Before putting the devices into operation, please observe the respective country-specific regulations.

This manual contains important laser system safety and operation information. Read and understand all instructions prior to powering on the laser unit the first time to avoid eye injury and to avoid breaking the law. Keep this manual in a safe place for future reference. Lasers can be hazardous and have unique safety considerations. Permanent eye injury and blindness is possible if lasers are used incorrectly. Pay close attention to each safety REMARK and WARNING statement in this manual.

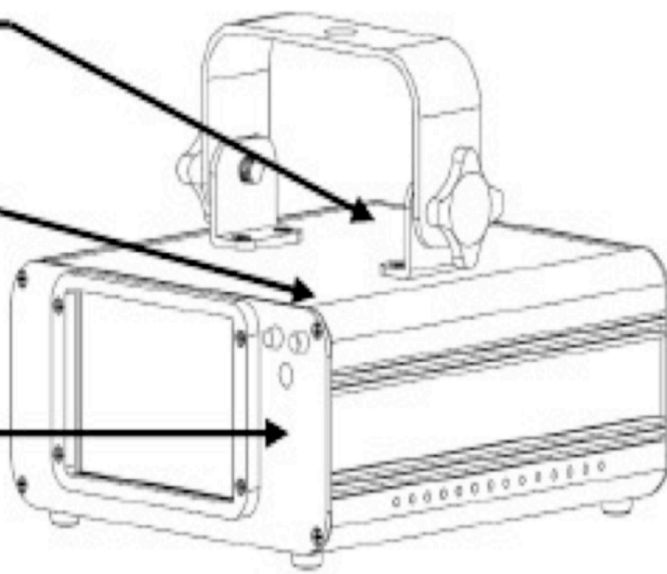

Caution – class 3b laser radiation,
When open, avoid exposure to beam

**CAUTION - CLASS 3B
LASER LIGHT WHEN OPEN
AVOID EXPOSURE TO BEAM**

Laser radiation avoid exposure
To beam class 3b laser product.

**LASER LIGHT
AVOID EXPOSURE TO BEAM
CLASS 3B LASER PRODUCT**

The label indicates the laser beam output aperture



**LASER
APERTURE**

For many years there have been serious safety issues with projecting laser beams directly into the audience (audience scanning). This is where a laser beam or image is projected into the crowd where people can reach and touch the image and also look directly into the laser image. One of the most dangerous situations, when using a laser, is hot spotting or use of single laser beams. A single point laser beam can be highly dangerous as this can damage eyesight or cause blindness. Hot spotting is where a laser image is projected, for example a circle / tunnel effect, with high intensity lines superimposed on it. The laser image should be the same intensity the whole way round the image. Here at Kam we put you and your customers' safety at the top of our agenda. After months of development we have installed the XY laser with unique safety circuitry which allows us to introduce an industry first! A laser that can scan the audience, providing certain guidelines are followed.

Our safety circuitry actually monitors the lasers functions by constantly checking the status of the lasers motors, diodes and programming. It performs this check approximately every 0.3 of a second. If any issues are found with any of the components of the laser, the unit will automatically shut itself down. This will prevent any possible chance of single laser beam pointing in case of failure of the scanner motors.

Please Note: When using any laser it is always best to act on the safe side! **Never take risks! Never** modify any laser unit. Beware of unwanted reflections.

The XY laser has a scanning projected scanning angle of 120 degrees by 90 degrees. This means that you can audience scan providing you adhere to some simple Laser Safety Rules.

What does the term audience scanning mean?

It is when a laser lighting effect is directed into the audience, normally to create tunnels or sheets of light that look like 3D objects that the crowd can touch or look towards.

What are the legal rules of audience scanning?

In the UK and Europe there is no law that specifically states that it is illegal to audience scan. But if a Laser Lighting effect can scan a laser effects into the audience, you need to be certain that the MPE is not being exceeded. If the MPE is exceeded there is a risk of members of the public sustaining eye injuries caused by the laser - which could lead to all sorts of adverse consequences. It is strongly recommend that you adhere to all Laser audience scan safety advice.

What is MPE?

Maximum Permissible Exposure. This is maximum amount of laser light that the eye can sustain before damage could start occurring.

What effects are more suited to audience scanning?

Effects that include stationary or slow moving beams **should be avoided at all times**. If you can see the beam moving through the path it is taking, it is almost certainly too dangerous to project into the audience. You should also avoid projecting effects that contain hot spots or dwell points in them. Dwell is where extra points are put into certain parts of the effect to help define a sharp corner etc. The energy present on these types of effect is not evenly dispersed and the hot spots can be hazardous. Smooth flowing effects, such as circular tunnels, are safer because they maintain a constant speed. Additionally, if you keep the whole effect panning over the audience, it helps to reduce the amount of time the laser beam is in any one person's eyes. The XY Laser is designed not to create such hot spot beams that can cause any issue and the integral laser safety cut out circuit will switch the laser off if any of the scanning motors fail or stop working correctly.

Does scanning an effect at a faster speed make things safer?

Generally yes, because the beam scans past the eye quicker therefore reducing the dose of laser energy into the eye. From this it follows that larger and faster moving images are safer.

What is the best way to operate the Laser?

Make sure the laser projects into a public area at least 3m above the ground level, preferably angled into the distance (to reduce the amount of close audience scanning) and **not** directly down into the audience. Always aim for the least audience scanning – particular at close quarters. Scanning at a distance will reduce to a minimum the possibility of the MPE being exceeded.

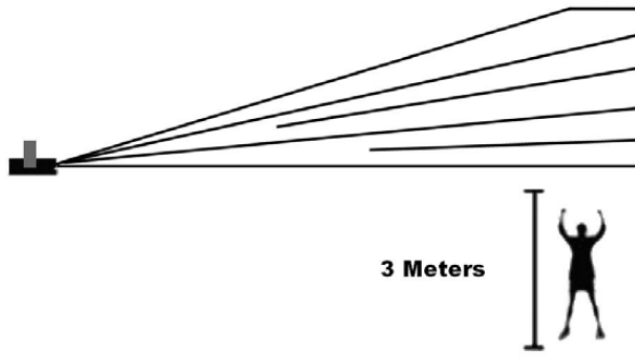

Avoid direct eye contact with laser beam



For your own safety and full laser safety regulation, we do strongly recommend you to take this optional switch!



CONTROL & FUNCTION

This can be used as an emergency fail safe
And should be connected to the safety interlock plug

Contents

1. XY laser unit x1
2. Safety keys x2
3. Interlock connecting plug x1
4. Remote control x1
5. Mains power lead x 1
6. User manual x1

The unit is supplied with a power plug appropriate to its voltage and destination.
Should any other connections be required they must be carried out with the following configuration.

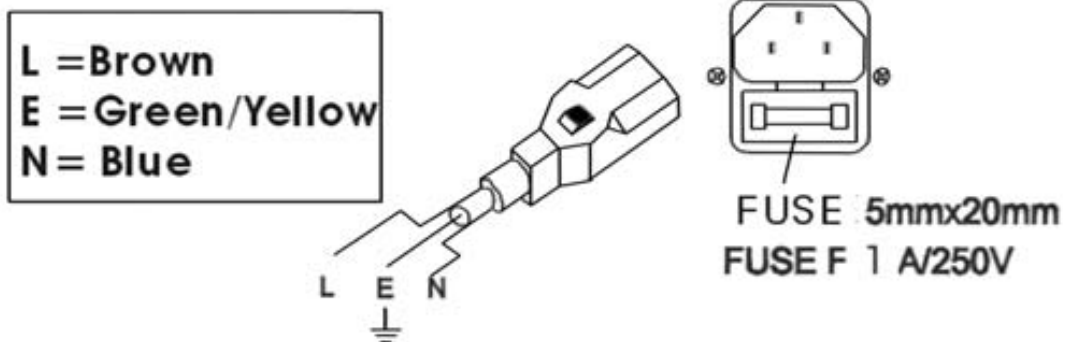

Cable (EU)	Cable (US)	Pin	International
Brown	Black	Live	L
Light Blue	White	Neutral	N
Yellow/Green	Green	Earth	

DMX-512 connection between fixtures

The fixture is equipped with 3-pin XLR sockets for DMX input and output. The sockets are wired in parallel. Only use a shielded twisted-pair cable designed for 3-pin XLR-plugs and connectors in order to connect the controller with the fixture or one fixture with another.

Occupation of the XLR-connection

DMX - output
XLR mounting-sockets (rear view):



- 1 - Shield
- 2 - Signal (-)
- 3 - Signal (+)

DMX-input
XLR mounting-plugs (rear view):

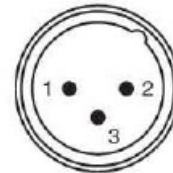

Building a serial DMX-chain

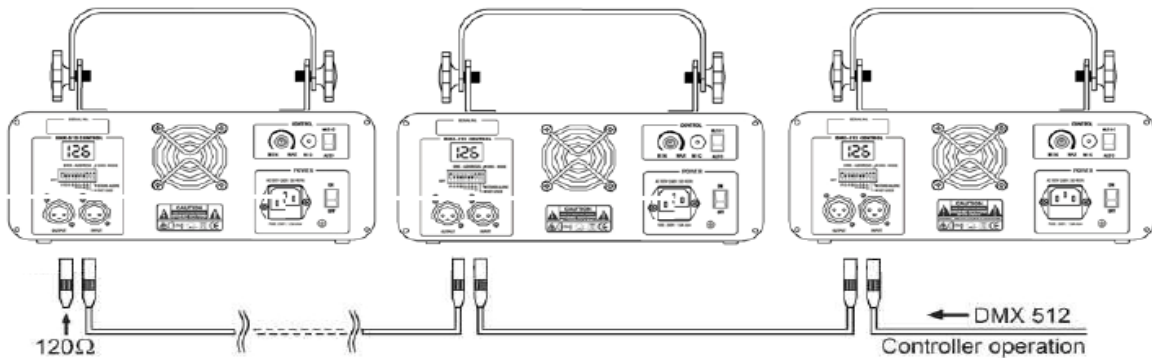

Functions

Operational Mode

When laser is powered on, LED monitor on rear panel shows the current operating mode Auto, sound adjustment, DMX, slave, Ren, test. With help of LED control panel, it is very easy to set and change the operation of the laser. After a setting is saved, the new mode information will be shown on the LED monitor at next power on.

FUNC	Mode/Function Option, to choose the operating mode laser
ENTER	Confirmation, to confirm all the setting or change of LED control panel
UP	Up/ Down, to change operation mode, parameter or DMX address
DOWN	

Operation

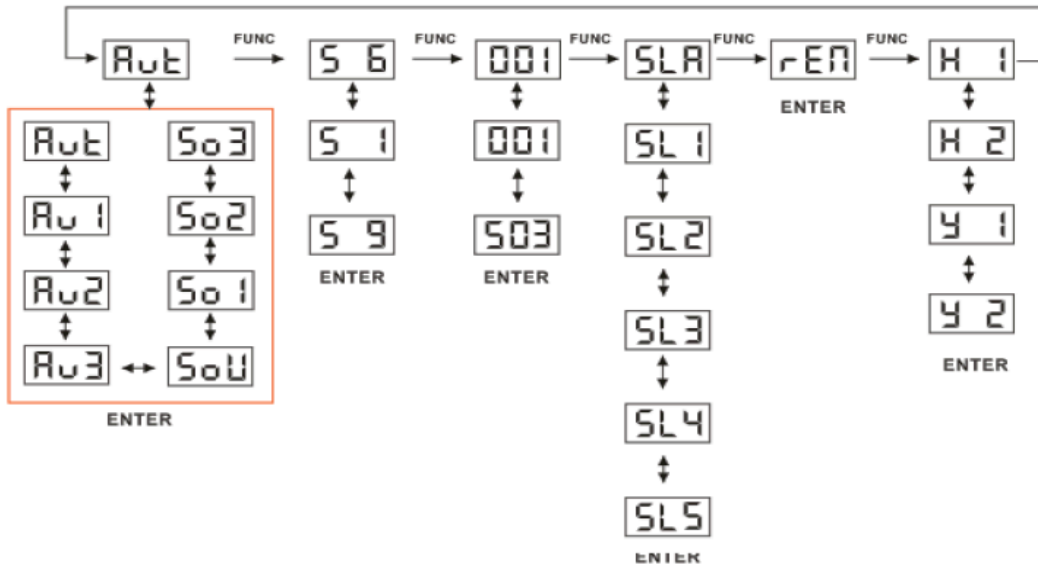

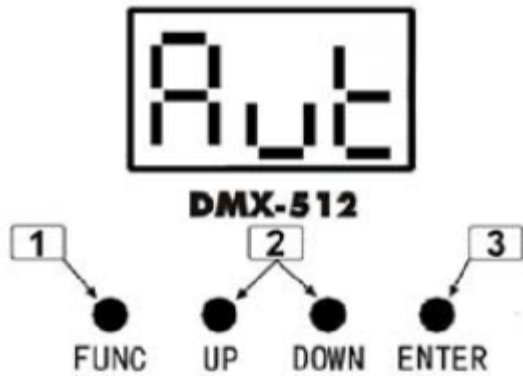

Auto mode

Press the menu button until AuT is displayed

In this mode all 3 colours of the laser will be displayed, press menu to confirm selection

While the auto mode is flashing

Use the up and down buttons to scroll through the auto menu

Aut1 =single colour 1

Aut = single colour 2

Au3 = single colour 3

Sou=3 colours in sound mode

Sou1= single colour 1sound activated

Sou2= single colour 1sound activated

Sou3= single colour 1sound activated

Pressing enter will select the desired mode

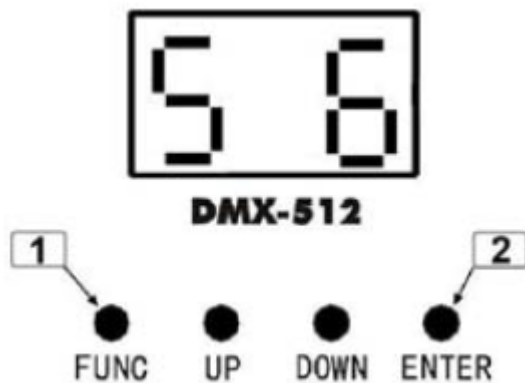

Adjusting the sound sensitivity

Press the menu button until the S menu is displayed

Use the up and down buttons to adjust the sensitivity

0= no sound sensitivity

9= maximum sensitivity

Press the enter button to confirm your selection

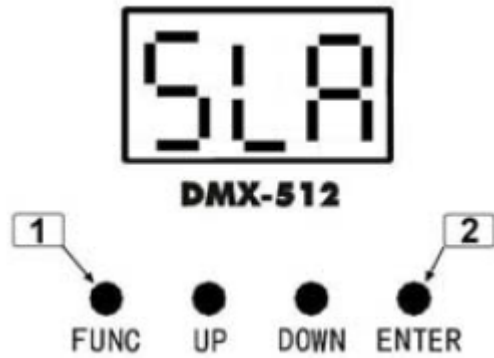

Connecting laser with DMX

Master slave mode (use without an external DMX controller)

Choose 1 unit to be the master unit . using the menu button select the desired mode eg. Auto or sound activated

Connect a 3 pin XLR cable from the DMX output of the master unit to the DMX input of the slave unit (continue this to connect all units in the chain)

using the menu button Select all other units to slave mode SLA press enter to confirm

Now all lasers will copy the master unit exactly

Note you Kam XY laser has 6 different slave modes SLA –SLA5 choosing a different slave mode will add a 2 second delay to the slave units giving a far more versatile laser show

Example

1. set the first unit to as master, and to the mode required auto / sound
2. set 2nd SLAVE unit to SLA 1
3. set the 3rd SLAVE unit to SLA 2

This will give slave (2) a 2 second delay before it mimics the movement from the master unit, and then SLA (3) will react 2 seconds after the SLA (2) unit giving a staggered lighting display effect

Connecting a DMX controller

Each XY laser uses 10 DMX channels each DMX channel controls a function on the unit

When connecting a DMX controller, connect a 3pin XLR lead from the DMX output of your controller to the DMX input of the laser unit

To control the laser with a DMX controller the unit will need to have a DMX address assigned to it

Press the menu button until the DMX address value is displayed 001 – 512

Press the up/down buttons until 001 is displayed

Press the enter button to confirm your selection

Note if the DMX address display is flashing this means that a DMX signal is NOT being received by the unit

If the display is not flashing a DMX signal is present

If more than one XY laser is to be controlled at the same time, there are 2 ways to do this

1. if all XY lasers are to be controlled the same, set all units with the same DMX address example 001
2. if individual control of each XY laser is required then each unit will need its own DMX address, example set unit 1 to 001 set unit 2 to 011 set unit 3 to 21 and so on adding 10 DMX channels to each unit
3. make sure that all units are at least 10 channels apart and that no channels cross over

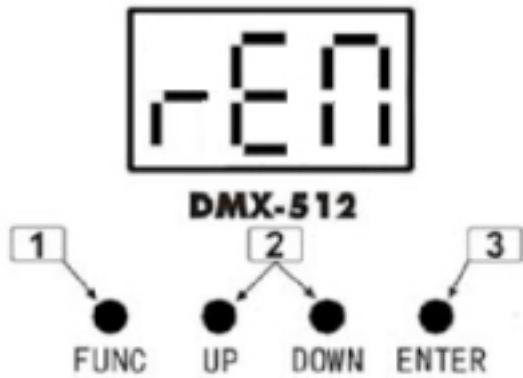

REN (remote control) mode

Press the menu button until rEN is displayed

Press enter to confirm selection

The unit is now in remote control function and will operate from the controls on the supplied infrared remote control.

Using the remote in Master/Slave mode

Set the first unit to REN mode and all other units in SLA. The remote will control all units in the DMX chain.

Remote control



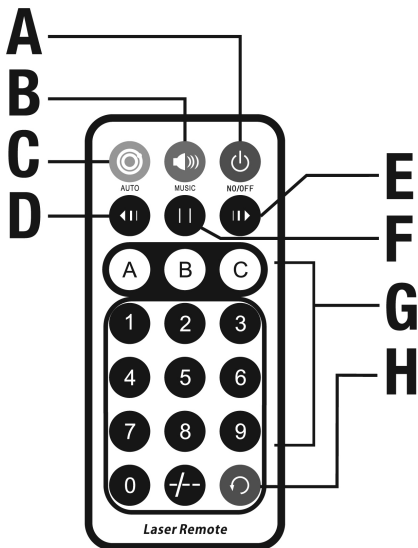

The unit can be operated by the supplied remote control. Make sure the unit is powered up and working, if no lasers are showing, press the red power button on the remote (A). Use this button to place the unit in standby mode when it is not needed. To completely turn the unit off, remove the power supply. The remote control's Auto button (C) sets the unit to Auto mode (see above). The Music button (B) sets the unit to Sound-to-Light mode. The two outer buttons in the second row of the remote (D and E) control the colour that the unit displays. The middle button of the second row (F) pauses the effect. (G) ABC do not have a function on this unit, 1-9 selects pre programmed patterns. (H) returns patterns to the beginning.





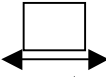







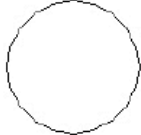

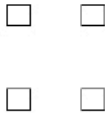
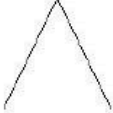



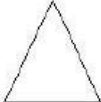

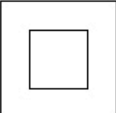

Test mode (tst)

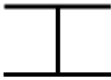
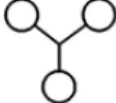
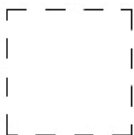
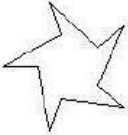
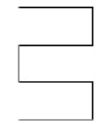
When the laser is in test mode this will only display a test image

This is for service purposes only

Channel	Value	Function
Channel 1	000-027	Blackout
	028-055	Auto show with all colours
	056-083	Auto show single colour 1
	084-111	Auto show single colour 2
	112-139	Auto show single colour 3
	140-167	Sound activated mode all colours
	168-195	Sound activated single colour 1
	196-223	Sound activated single colour 2
	224-251	Sound activated single colour 3
	252-255	DMX mode
Channel 2	000-255	Pattern select see chart
Channel 3 colour	000-049	Original 3 colours
	050-074	Colour 1
	075-099	Colour 2
	100-124	Colour 3
	125-149	Alternating colour 1 & 2
	150-174	Alternating colour 2 & 3
	175-199	Alternating colour 1 & 3
	200-224	Alternating colour 1 & 2 & 3
	225-255	Colour rolling
Channel 4 colour speed	000-004	stop
Channel 5 zooming 	005-255	Speed slow to fast
	000-127	100%-5% size
	128-169	Zooming in
	170-209	Zooming out
	210-255	Zooming in and out
Channel 6 Y axis 	000-127	128 positions on X
	128-191	Clockwise movement
	192-255	Anti clockwise movement
Channel 7 X axis 	000-127	128 positions on Y
	128-191	Clockwise movement
	192-255	Anti clockwise movement
Channel 8 Y axis rotation 	000-127	0-359 degrees rotation
	128-191	Clockwise rotation
	192-255	Anti Clockwise rotation
Channel 9 Xaxis rotation 	000-127	0-359 degrees rotation
	128-191	Clockwise rotation
	192-255	Anti Clockwise rotation
Channel 10 axis rotaion 	000-127	0-359 degrees rotation
	128-191	Clockwise rotation
	192-255	Anti Clockwise rotation

Pattern list in channel 2

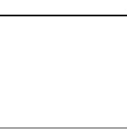
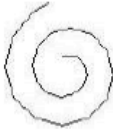
DMX	PATTERNS	DMX	PATTERNS	DMX	PATTERNS	DMX	PATTERNS
000-007		064-071		128-135		192-199	
008-015		072-079		136-143		200-207	
016-023		080-087		144-151		208-215	
024-031		088-095		152-159		216-223	
032-039		096-103		160-167		224-131	
040-047		104-111		168-175		232-239	
048-055		112-119		176-183		240-247	

Specifications

Mains input: **AC100V-240V / 50Hz-60Hz**

Fuse: **250v / 1A / slow blow / 20mm glass**

Power consumption: **15w**

Sound-to-Light/music control: **via internal mic**

Scanning system: **3K stepper motor**

Scanning angle: **Pan >120 degrees / Tilt >90 degrees**

Laser classification: **Class 3b**

Laser safety standard: **en60825-1 2007**

Operating temperature: **10-40 degrees C**

DMX connection: **3 pin XLR**

DMX channels: **10**

Dimensions (see diagram below): **180 x 80 x 195mm (WxHxD)** not including bracket

Weight: **2Kg**

Laser power

RGY 100mW red + 40mW green = 140mW yellow

RBP 100mW red + 120mW blue = 220mW pink

GBC 40mW green + 120mW blue = 160mW cyan

Specifications subject to change without prior notice.

