

bq500212A bqTESLA Wireless Power TX EVM

The bqTESLA™ wireless power transmitter evaluation module from Texas Instruments is a high-performance, easy-to-use development module for the design of wireless power solutions. The single-channel transmitter enables designers to speed the development of their end-applications. The bq500212A EVM evaluation module (EVM) provides all the basic functions of a Qi-compliant, wireless charger pad. The EVM is intended to be used with bq51013BEVM-764 or any other Qi-compliant receiver. The EVM supports both the WPC 1.0 and WPC 1.1 receivers. The transmitter EVM is a 5-V input design which powers a standard WPC low-power 5-W receiver.

Contents

1	Applications	2
2	bq500212AEVM-550 Electrical Performance Specifications	2
3	Modifications	2
4	Connector and Test Point Descriptions	3
	4.1 Input/Output Connections	3
	4.2 Test Point Descriptions	4
5	Schematic and Bill of Materials	6
6	Test Setup	11
	6.1 Equipment	11
	6.2 Equipment Setup	12
7	bq500212AEVM-550 Assembly Drawings and Layout	14
8	Reference	17
9	FCC and IC Regulatory Compliance	18

List of Figures

1	bq500212AEVM-550 Schematic, Page 1 of 3	6
2	bq500212AEVM-550 Schematic, Page 2 of 3	7
3	bq500212AEVM-550 Schematic, Page 3 of 3	8
4	Equipment Setup	12
5	Efficiency versus Power, bq500212AEVM-550 Transmitter and HPA764 Receiver.....	13
6	Assembly Top.....	15
7	Top Silk	15
8	Top Layer.....	16
9	Layer 2.....	16
10	Layer 3.....	17
11	Bottom Layer.....	17

List of Tables

1	bq500212AEVM-550 Electrical Performance Specifications	2
2	Bill of Materials	8

1 Applications

The bq500212AEVM-550 evaluation module demonstrates the transmitter portion of the bqTESLA™ wireless power system. This transmitter EVM is a complete transmitter-side solution that powers a bqTESLA™ receiver. The EVM requires a single 5-V power supply capable of up to 2 A to operate and combines the transmitter electronics, input power socket, LED indicators, and the transmitting coil on the single printed-circuit board (PCB). The open design allows easy access to key points of the electrical schematic.

This EVM has the following features:

- WPC 1.1 Foreign Object Detection (FOD) and WPC 1.0 Parasitic Metal Object Detection (PMOD)
- Dynamic Power Limiting™ (DPL) allows operation from a 5-V supply with limited current capability (for example, a USB port)
- 5-V input power which is really available
- Transmitter-coil mounting pad providing the correct receiver interface
- Compact power section design using the CSD97376 NexFET power stage
- Standard WPC A11-type transmitter coil with no magnet
- LED indicates power transfer or power fault state

2 bq500212AEVM-550 Electrical Performance Specifications

[Table 1](#) provides a summary of the EVM performance specifications. All specifications are given for an ambient temperature of 25°C.

Table 1. bq500212AEVM-550 Electrical Performance Specifications

Parameter		Notes and Conditions	Min	Typ	Max	Unit
Input Characteristics						
V_{IN}	Input voltage		4.50	5.0	5.50	V
I_{IN}	Input current	$V_{IN} = \text{Nom}$, $I_{OUT} = \text{Max}$		1.50	2.0	A
	Input no-load current	$V_{IN} = \text{Nom}$, $I_{OUT} = 0 \text{ A}$		200		mA
	Input stand-by current	$V_{IN} = \text{Nom}$		20		mA
Output Characteristics – Receiver bq51013BEVM-764						
V_{OUT}	Output voltage	$V_{IN} = \text{Nom}$, $I_{OUT} = \text{Nom}$	4.5	5	5.1	V
	Output ripple	$V_{IN} = \text{Nom}$, $I_{OUT} = \text{Max}$			200	mV _{PP}
I_{OUT}	$V_{IN} = \text{Min to Max}$	$V_{IN} = \text{Min to Max}$	0		1	A
	Output overcurrent	$V_{IN} = \text{Nom}$	1		1.1	A
Systems Characteristics						
F_S	Switching frequency	Switching frequency varies with load	110		205	kHz
η_{pk}	Peak efficiency	$V_{IN} = \text{Nom}$, P Out RX = 2.5 W		72		%
η	Full-load efficiency	$V_{IN} = \text{Nom}$, $I_{OUT} = \text{Max}$		70		%

3 Modifications

See the datasheet ([SLUSBD6](#)) when changing components.

Use LED Mode – Resistor R23 to change the behavior of the status LED, D5, D7 and D9. The standard value is 42.2 kΩ for control option 1, see the datasheet for additional settings.

NTC – Connector JP1 provides the option for connecting a negative temperature coefficient (NTC) sensor for thermal protection, see the datasheet for additional settings.

L1 and L3 – Common Mode Choke for additional input power filtering or output TX Coil.

L1 – DLW5BTN101SQ2L – 6 A, 9 mΩ, muRata

L3 – DLW5BTN102SQ2L – 2 A, 24 mΩ, muRata

4 Connector and Test Point Descriptions

4.1 Input/Output Connections

The connection points are described in [Section 4.1.1](#) through [Section 4.1.8](#).

4.1.1 J1 – V_{IN}

Input power 5 V ±100 mV, return at J2.

4.1.2 J2 – GND

Return for input power, input at J1.

4.1.3 J3 –JTAG

Factory use only.

4.1.4 J4 – Serial Interface

Factory use only.

4.1.5 J5 - Micro USB

Input power connector.

4.1.6 JP1 – NTC

The connection point for the external temperature sensor. See the datasheet for more information.

4.1.7 JP2 – LED Mode

External connection for LED MODE resistor, if R23 is removed.

4.1.8 JP3 – FOD / PMOD Enable (Not Used)

If LOSS_THR resistor (Pin 43 to Gnd) is used, JP3 can be used to Enable or Disable FOD / PMOD. See the datasheet ([SLUSBD6](#)) for additional details.

4.2 Test Point Descriptions

The test points are described in [Section 4.2.1](#) through [Section 4.2.20](#).

4.2.1 TP1 – Coil Monitor L / C

Coil signal at junction between coil and capacitors.

4.2.2 TP2 – DPWM Signal

Digital output signal from bq500212A to H-Bridge drive for U3.

4.2.3 TP3 – DPWM Signal

Digital output signal from bq500212A to H-Bridge drive for U2.

4.2.4 TP4 – Analog GND

Low-noise GND

4.2.5 TP5 – Not Used

Not used.

4.2.6 TP6 – Not Used

Not used.

4.2.7 TP7 – Not Used

Not used.

4.2.8 TP8 – Not Used

Not used.

4.2.9 TP9 – 3.3-VDC

Voltage for low-power circuits, switched ON/OFF using U5 EN.

4.2.10 TP10 - Filtered 3.3 V

3.3-V output with additional filtering for A-to-D converters.

4.2.11 TP11 – Not Used

Not used.

4.2.12 TP12 – Not Used

Not used.

4.2.13 TP13 – Demodulation Comm + Output

Primary communications channel, input to bq500212A, U1 from demodulation circuit.

4.2.14 TP14 – Snooze

Output from bq500212A, U1 starts Snooze timer circuit.

4.2.15 TP15 – Not Used

Not used.

4.2.16 TP16 – Not Used

Not used.

4.2.17 TP17 – Not Used

Not used.

4.2.18 TP18 – Spare Pin

Unused output from bq500212A.

4.2.19 TP19 – I_Sense

Input current-sense voltage, scale 1 V = 1 A.

4.2.20 TP20 -- Sleep

Output from bq212A, U1 starts Sleep timer circuit.

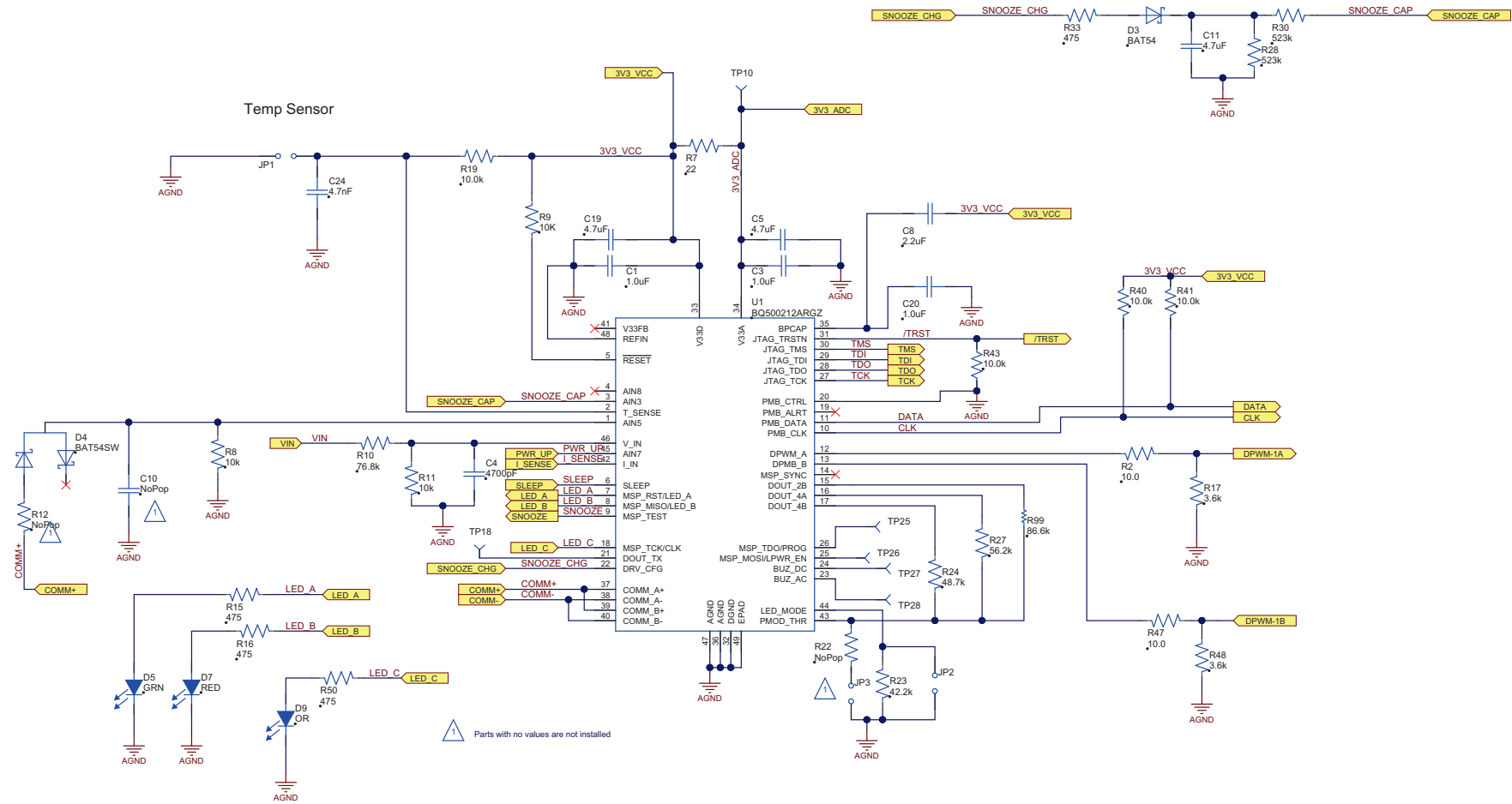

Figure 2. bq500212AEVM-550 Schematic, Page 2 of 3

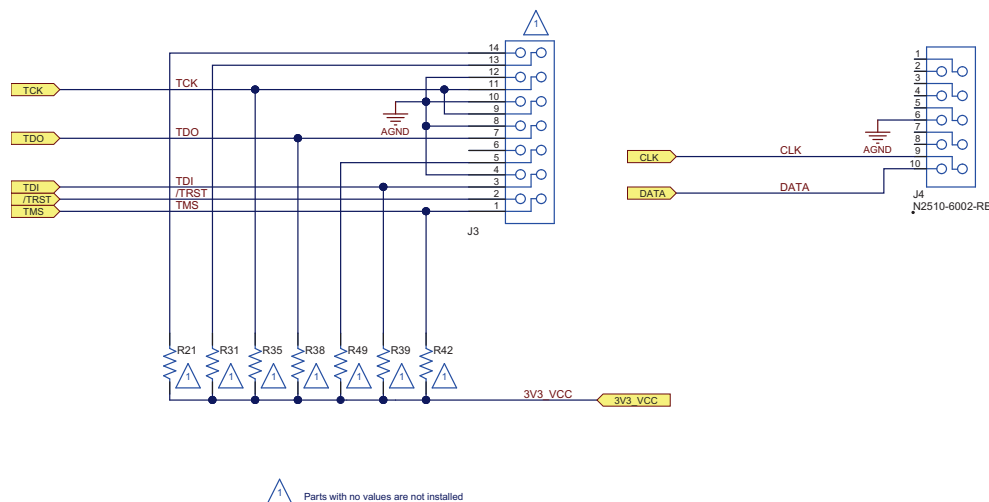

Figure 3. bq500212AEVM-550 Schematic, Page 3 of 3

Table 2 contains the BOM for this EVM.

Table 2. Bill of Materials

Designator	Qty	Description	Manufacturer	Part Number	Alternate Manufacturer	Alternate PartNumber
C1, C3, C20, C34	4	Capacitor, Ceramic, 1UF 16V 10% X7R 0603	TDK	C1608X7R1C105K080AC		
C2, C17	2	CAP, CERM, 4.7uF, 10V, +/-10%, X5R, 0805	AVX	0805ZD475KAT2A		
C4	1	Capacitor, Ceramic, 4700PF 50V 5% NP0 0603	TDK	C1608C0G1H472J080AA	Digi-Key	445-7400-2-ND
C5	1	Capacitor, Ceramic, 4.7uF, 10V, X7R, 20%	TDK	CGB3B1X5R1A475M055AC		
C6, C15, C16, C31	4	Capacitor, Ceramic, 0.1UF 50V 10% X7R 0603	TDK	C1608X7R1H104K080AA	TDK	C1608X7R1H104K080AA
C7	1	Capacitor, Ceramic, 22UF 25V 10% X5R 1210	Murata	GRM32ER61E226KE15L	Digi-Key	490-3889-1
C8	1	Capacitor, Ceramic, 2.2UF 10V 10% X7R 0603	TDK	C1608X7R1A225K080AC	Digi-Key	445-5958-1
C9, C13	2	CAP, CERM, 1uF, 16V, +/-10%, X5R, 0603	Kemet	C0603C105K4PACTU		
C11, C25	2	Capacitor, Ceramic, 4.7UF 10V 20% X5R 0603	TDK	CGB3B1X5R1A475M055AC		
C12	1	Capacitor, Ceramic Chip, 2.2UF 16V 10% X7R 1206	TDK	C3216X7R1C225K/1.60	Digi-Key	445-1384-1
C14	1	Capacitor, Ceramic, 33PF 50V 5% NP0 0603	TDK	C1608C0G1H330J080AA	Digi-Key	445-1275-1
C18	1	Capacitor, Ceramic, 4700pF, 50V, X7R, 10%	TDK	C1608C0G1H472J080AA	Digi-Key	445-7400-2-ND
C19, C26	2	Capacitor, Ceramic, 4.7UF 10V 20% X5R 0603	TDK	CGB3B1X5R1A475M055AC		
C21	1	Capacitor, Ceramic, 0.01uF, 50V, X7R, 10%	TDK	C1608X7R1H103K080AA	Digi-Key	445-1311-1
C22	1	Capacitor, Ceramic, 4.7UF 10V 20% X5R 060	TDK	CGB3B1X5R1A475M055AC		
C23, C33	2	CAP, CERM, 10uF, 10V, +/-10%, X5R, 1210	Kemet	C1210C106K8PACTU		
C24	1	Capacitor, Ceramic, 4.7nF, 50V, X7R, 10%	TDK	CGA3E2X7R1H472K080AD	Digi-Key	445-8828-1
C27, C28, C29	3	CAP, CERM, 0.1uF, 100V, +10%, X7R, 1206	TDK	C3216X7R2A104K		

Table 2. Bill of Materials (continued)

Designator	Qty	Description	Manufacturer	Part Number	Alternate Manufacturer	Alternate PartNumber
C30	1	CAP CER 0.1UF 50V 10% NP0 1210	TDK Corporation	C3225C0G1H104K250AA		
C32	1	Capacitor, Ceramic Chip, 100UF 6.3V 20% X5R 1206	TDK	C3216X5R0J107M160AB	TDK	445-6008-1
D1	1	Diode, LED 2X1.2MM 470NM BL WTR CLR SMD	Kingbright Corp	APT2012QBC/D	Digi-Key	754-1437-1-ND
D2, D3, D8	3	Diode, Schottky, 200-mA, 30-V	Vishay-Liteon	BAT54		
D4	1	Diode, Dual Schottky, 200mA, 30V	On Semi	BAT54SWT1G		
D5	1	Diode, LED 2X1.2MM 568NM GN WTR CLR SMD	Kingbright Corp	APT2012SGC	Digi-Key	754-1131-1
D7	1	Diode, LED 2X1.2MM 640NM RD WTR CLR SMD	Kingbright Corp	APT2012SRCPRV	Digi-Key	754-1132-1-ND
D9	1	Diode, LED 2X1.2MM 601NM OR WTR CLR SMD	Kingbright Corp	APT2012SECK	Digi-Key	754-1130-1
L2	1	TX Coil	Würth Elektronik	760-308-111		
Q4, Q7	2	MOSFET, Nch, 50V, 0.22A, 3.5 Ohm	Fairchild	BSS138		
Q8	1	Transistor, Digital NPN, 50 V, 100 mA	Rohm	DTC114EUA		
R1, R3, R37	3	Resistor, Chip, 1.0 OHM 1/10W 5% 0603 SMD	Yageo, Yageo, Yareo	RC0603JR-071RL	Digi-Key	311-1.0GRCT
R2, R47	2	Resistor, Chip, 10 OHM 1/10W 5% 0603 SMD	Yageo	RC0603JR-0710RL	Digi-Key	311-10GR
R4, R46, R55	3	Resistor, Chip, 1.00K OHM 1/10W 1% 0603 SMD	Std, Yageo, Yageo	RC0603FR-071KL	[NoValue], Digi-Key, Digi-Key	[NoValue], 311-1.00KH, 311-1.00KH
R5, R8, R9, R11, R18, R19, R40, R41, R43, R52	10	RES 10.0K OHM 1/10W 1% 0603 SMD	Yageo	RC0603FR-0710KL		
R6	1	Resistor, Chip, 100K OHM 1/10W 1% 0603 SMD	Yageo	RC0603FR-07100KL	Digi-Key	311-100KHRTR
R7	1	Resistor, Chip, 22 OHM 1/8W 5% 0805 SMD	Yageo	RC0805JR-0722RL	Digi-Key	311-22ARCT
R10	1	Resistor, Chip, 76.8K OHM 1/10W 1% 0603 SMD	Yageo	RC0603FR-0776K8L	Digi-Key	311-76.8KHRCT
R13, R20, R34, R44	4	RES, 0 ohm, 5%, 0.25W, 1206	Vishay-Dale	CRCW1206000Z0EA		
R14	1	Resistor, Chip, 12.1K OHM 1/10W 1% 0603 SMD	Yageo	RC0603FR-0712K1L	Digi-Key	311-12.1KHRCT
R15, R16, R33	3	Resistor, Chip, 475 OHM 1/10W 1% 0603 SMD	Yageo	RC0603FR-07475RL	Digi-Key	311-475HRCT, 311-475HRCT, 311-475HRC
R17	1	Resistor, Chip, 3.60K OHM 1/10W 1% 0603 SMD	Yageo	RC0603FR-073K6L	Digi-Key	311-3.60KHR
R22	1	Resistor, Chip, 56.2K OHM 1/10W 1% 0603 SMD	Yageo	RC0603FR-0756K2L	Digi-Key	311-56.2KHRCT
R23	1	Resistor, Chip, 42.2K OHM 1/10W 1% 0603 SMD	Yageo	RC0603FR-0742K2L	Yageo	311-42.2KHRCT
R25, R28, R30, R54	4	Resistor, Chip, 523K OHM 1/10W 1% 0603 SMD	Yageo	RC0603FR-07523KL	Digi-Key	311-523KHRCT
R26, R29	2	Resistor, Chip, 10 OHM 1/10W 5% 0603 SMD	Yageo	RC0603JR-0710RL	Digi-Key	311-10GR, 311-10GRCT
R32	1	Resistor, Chip, 0.02 OHM 1/2W 1% 0805 SMD	Panasonic Electronic Components	ERJ-6BWF020V		
R36	1	Resistor, Chip, 1.0 OHM 1/10W 5% 0603 SMD	Yareo	RC0603JR-071RL	Digi-Key	311-1.0GRCT
R45	1	RES, 1.0Meg ohm, 5%, 0.1W, 0603	Vishay-Dale	CRCW06031M00JNEA		
R48	1	Resistor, Chip, 3.60K OHM 1/10W 1% 0603 SMD	Yageo	RC0603FR-073K6L	Digi-Key	311-3.60KHRCT
R50	1	Resistor, Chip, 475 OHM 1/10W 1% 0603 SMD	Yageo	RC0603FR-07475RL	Digi-Key	311-475HRCT
R51	1	Resistor, Chip, 1.00M OHM 1/10W 1% 0603 SMD	Yageo	RC0603FR-071ML	Digi-Key	311-1.00MHRCT
R53	1	Resistor, Chip, 2.00M OHM 1/10W 1% 0603 SMD	Yageo	RC0603FR-072ML	Digi-Key	311-2.00MHRCT
R99	1	RES, 86.6k ohm, 1%, 0.1W, 0603	Yageo America	RC0603FR-0786K6L		
U1	1	IC, Qi Compliant Wireless Power Transmitter Manager	TI	BQ500212ARGZ	None	
U2, U3	2	IC, Synchronous Buck NexFETPower Stage	TI	CSD97376CQ4M	None	

Table 2. Bill of Materials (continued)

Designator	Qty	Description	Manufacturer	Part Number	Alternate Manufacturer	Alternate PartNumber
U5	1	IC REG LDO 3.3V 200mA SOT-23-5	TI	TLV70033DDC	Digi-Key	
U7	1	IC, Current Monitor, High or Low Side Measurement, Bi-Directional Zero-Drift Series	TI	INA199A1DCKR	None	
C10	0	Capacitor, Ceramic, 50V, C0G, 5%	TDK	C1608C0G1H330J080AA		
L1, L3	0	Inductor, Toroid, yyA, zzmilliohm	muRata	DLW5BSNxxxSQ2		
R12, R21, R31, R35, R38, R39, R42, R49	0	Resistor, Chip, 1/16W, 1%	N/A	Open		
R24	0	Resistor, Chip, 1/16W, 1%	Yageo	RC0603FR-0748K7L	DigiKey	311-48.7KHRCT-ND
R27	0	Resistor, Chip, 56.2K OHM 1/10W 1%	Yageo	RC0603FR-0756K2L		

6 Test Setup

6.1 Equipment

6.1.1 bqTESLA™ Receiver

Use the bq51013BEVM-764 or a Qi-compliant receiver to work with this EVM.

6.1.2 Voltage Source

The input voltage source must provide a regulated DC voltage of 5 V and deliver at least 2-A continuous load current; current limit must be set to 3 A.

CAUTION

To help assure safety integrity of the system and minimize risk of electrical shock hazard, always use a power supply providing suitable isolation and supplemental insulation (double insulated). Compliance to IEC 61010-1, Safety Requirements for Electrical Equipment for Measurement, Control and Laboratory Use, Part 1, General Requirements, or its equivalent is strongly suggested, including any required regional regulatory compliance certification approvals. Always select a power source that is suitably rated for use with this EVM as referenced in this user manual.

External Power Supply Requirements:

Nom Voltage: 5.0 VDC

Max Current: 3.0 A

Efficiency Level V

External Power Supply Regulatory Compliance Certifications: Recommend selection and use of an external a power supply which meets TI's required minimum electrical ratings in addition to complying with applicable regional product regulatory/safety certification requirements such as (by example) UL, CSA, VDE, CCC, PSE, and so forth.

6.1.3 Meters

Monitor the output voltage at the bq51013BEVM-764 test point TP7 with a voltmeter. Monitor the input current into the load with an appropriate ammeter. You can also monitor the transmitter input current and voltage, but the meter must use the averaging function for reducing error, due to communications packets.

6.1.4 Loads

A single load is required at 5 V with a maximum current of 1 A. The load can be resistive or electronic.

6.1.5 Oscilloscope

Use a dual-channel oscilloscope with appropriate probes to observe the COMM_DRV signal at bq51013BEVM-764 TP3 and other signals.

6.1.6 Recommended Wire Gauge

For proper operation, use 22-AWG wire when connecting the EVM to the input supply and the bq51013BEVM-764 to the load.

6.2 Equipment Setup

- With the power supply OFF, connect the supply to the bqTESLA™ transmitter.
- Connect the V_{IN} positive power source to J1, and connect the negative terminal of the V_{IN} source to J2.
- Do not place the bqTESLA™ receiver on the transmitter. Connect a load to J3 with a return to J4, monitor current through the load with the ammeter, and monitor the current to the load at TP7. All voltmeters must be Kelvin connected (at the pin) to the point of interest.

6.2.1 Equipment Setup Diagram

The diagram in Figure 4 shows the test setup.

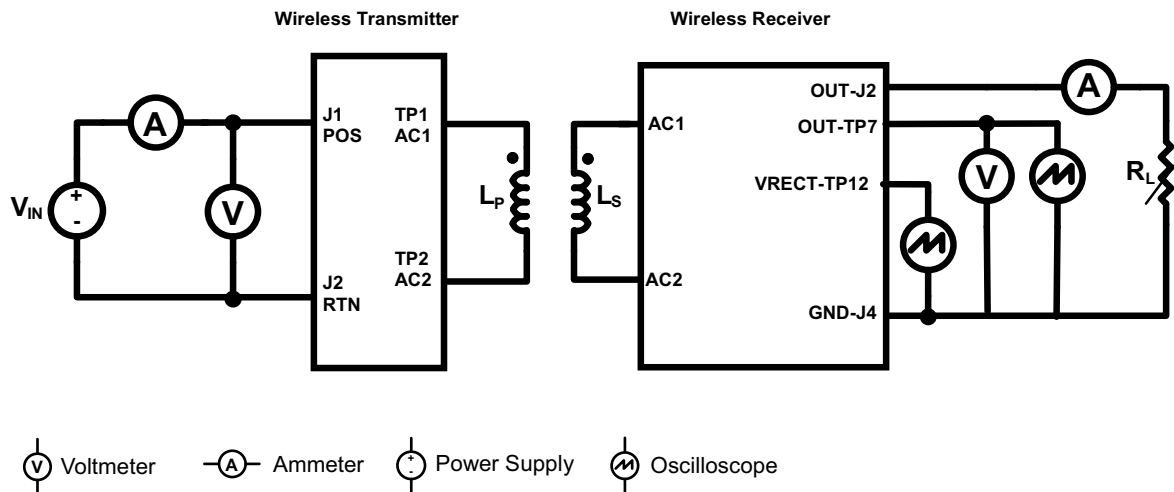

Figure 4. Equipment Setup

6.2.2 EVM Procedures

This section guides the user through a few general test procedures to exercise the functionality of the presented hardware. Some key notes follow.

6.2.2.1 Start-Up No Receiver

Turn on V_{IN} , and observe that the blue power LED, D1, illuminates. Status LEDs D7, D9 and D5 are OFF until the power transfer starts.

Apply the scope probe to the test point, TP1, and observe single-pulse bursts approximately every 500 ms. This is a Digital Ping to begin communications with a receiver placed on the TX coil.

6.2.2.2 Apply Receivers

Place the bq51013BEVM-764 EVM on the top of the transmitting coil. Align the centers of the receiving and transmitting coils across each other. In the next few seconds, observe that the status LED, D5, flashes green, indicating that communication between the transmitter and the receiver is established and that power transfer has started.

- The status LED, D5, flashes a green light during power transfer.
- Typical output voltage is 5 V, and the output current range is 0 mA to 1 A.
- Observe a continuous sine-wave on the test point TP1 when power transfer is active; the frequency is between 110 kHz and 205 kHz.
- Make tests and measurements applicable to a normal 5-V power supply.

6.2.2.3 Efficiency

To measure system efficiency, measure the output voltage, the output current, input voltage, and input current and calculate efficiency as the ratio of the output power to the input power. Connect voltage meters at the input and output of TX and RX (see Figure 4). Average the input current; the comm pulses modulate the input current, distorting the reading. See Figure 5 for efficiency. Figure 5 shows efficiency with standard EVM (C30-COG but C29, C28, and C27 - X7R). Also shown is efficiency with C30, C29, C28, and C27 all capacitors COG type.

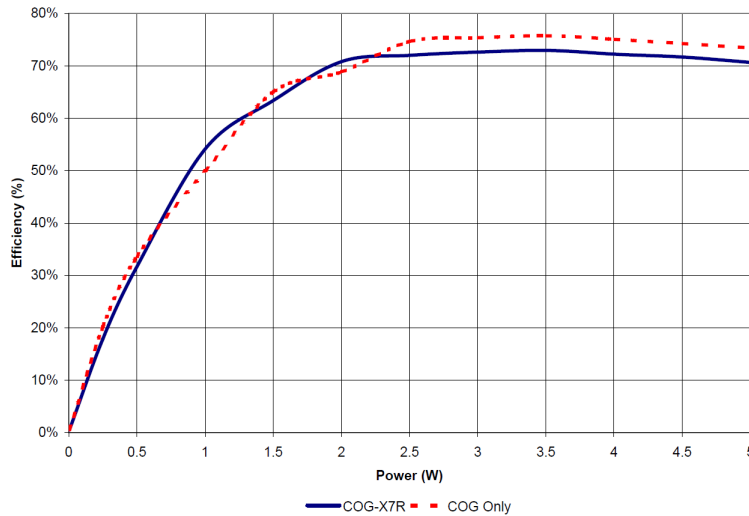

Figure 5. Efficiency versus Power, bq500212A EVM-550 Transmitter and HPA764 Receiver

6.2.2.4 Efficiency Improvements

Efficiency improvements can be made with component changes. The EVM uses an integrated power stage device that combines both the driver and two MOSFETs into one package, CSD97376. Similar devices with lower $R_{DS(on)}$ MOSFETs are available. The CSD97374 reduces $R_{DS(on)}$ by about 50% and improves efficiency by 2% to 4%. This device is pin-to-pin compatible and is a drop in replacement.

To reduce cost, the EVM uses a mix on COG and X7R capacitors for the resonant capacitors, C28, C29, C30 and C27. X7R is lower cost but has higher ESR which results in higher loss. If all COG capacitors are used, efficiency increases by 2% to 4%.

Note that changing the efficiency of the unit and reducing loss (or increasing loss) changes the FOD performance and may require re-calibration. This would require FOD_CAL resistor, R99 to change along with FOD_Threshold resistor, R24. FOD Calibration procedure would need to be repeated.

6.2.2.5 Dynamic Power Limiting

Dynamic Power Limiting (DPL) allows operation from a 5-V supply with limited current capability. Input voltage is monitored at Pin 46 through a voltage divider network. When input voltage decreases to 4.2 V, the operating point is adjusted to reduce load and increase input voltage to 4.5 V.

6.2.2.6 Thermal Protection, NTC

Thermal protection is provided by an NTC resistor connected to JP1. At 1 V on the sense side (U1-2), the thermal fault is set, and the unit is shut down. The status LED, D5, illuminates red. The typical resistor value for fault is 850 Ω . The system tries to restart in 5 minutes.

6.2.2.7 Foreign Object Detection

The bq500212A EVM incorporated Foreign Object Detection (FOD) call in WPC 1.1. Power loss is calculated by comparing the power sent to the receiver (RX) with the power the RX reported receiving, less known power loss. The transmitter determines the power sent to the RX by measuring input power and calculating internal losses. The RX measures the power it received and also calculates losses. The RX sends this information to the driver (TX) in a digital word, message packet. Unaccounted for power loss is presumed to be a foreign object on the charging pad. Should this lost power exceed the threshold set by R24, a FOD fault is set and power transfer is stopped.

Three key measurements for the TX FOD calculation:

- **Input Power** – Product of input voltage and current. Input voltage is measured at Pin 46 through R10 and R11. Input current is measured using sense resistor R32 and current sense amp U7. Both measurements need to be very accurate.
- **Power Loss in Transmitter** – This is an internal calculation based on the operating point of the transmitter. The calculation is adjusted using FOD_Cal resistor, R99. This calculation changes with external component changes in the power path such as MOSFETs, resonant capacitors, and TX coil. Recalculation of R99 and R24 will be required.
- **Receiver Reported Power** – The receiver calculates and reports power it receives in the message packet “Received Power Packet (0X04)”.

The FOD threshold on the EVM is set to 350 mW, R24 is set to 48.7 kΩ. Increasing R24 increases the threshold and reduces the sensitivity to foreign objects.

This loss threshold is determined after making a measurement of transmitter performance using a FOD Calibration Receiver similar to unit manufactured by Avid® Technology. Contact Texas Instruments for the Foreign Object Detection Calibration Procedure for bq500212A.

6.2.2.8 WPC Certification

The bq500212AEVM-550 was tested and certified to WPC version 1.1.1, July 2013.

7 bq500212AEVM-550 Assembly Drawings and Layout

Figure 6 through Figure 11 show the design of the bq500212AEVM PCB. The EVM has been designed using a 4-layer, 2-oz, copper-clad circuit board 13.2 cm × 7.24 cm with all components in a 4.0-cm × 5.0-cm active area on the top side and all active traces to the top and bottom layers to allow the user to easily view, probe, and evaluate the bq500212A control IC in a practical application. Moving components to both sides of the PCB or using additional internal layers offers additional size reduction for space-constrained systems. Gerber files are available for download from the EVM product folder.

A 4-layer PCB design is recommended to provide a good low-noise ground plane for all circuits. A 2-layer PCB presents a high risk of poor performance. Grounding between the bq500212A GND pin 47, 36, and 32 and filter capacitor returns C19, C1, C5, and C3 should be a good low-impedance path.

Coil Grounding – A ground plane area under the coil is recommended to reduce noise coupling into the receiver. The ground plane for the EVM is slightly larger than the coil footprint and grounded at one point back to the circuit area.

Note: The clear plastic cover thickness (0.93 in or 2.4 mm) is the z-gap thickness for the transmitter.

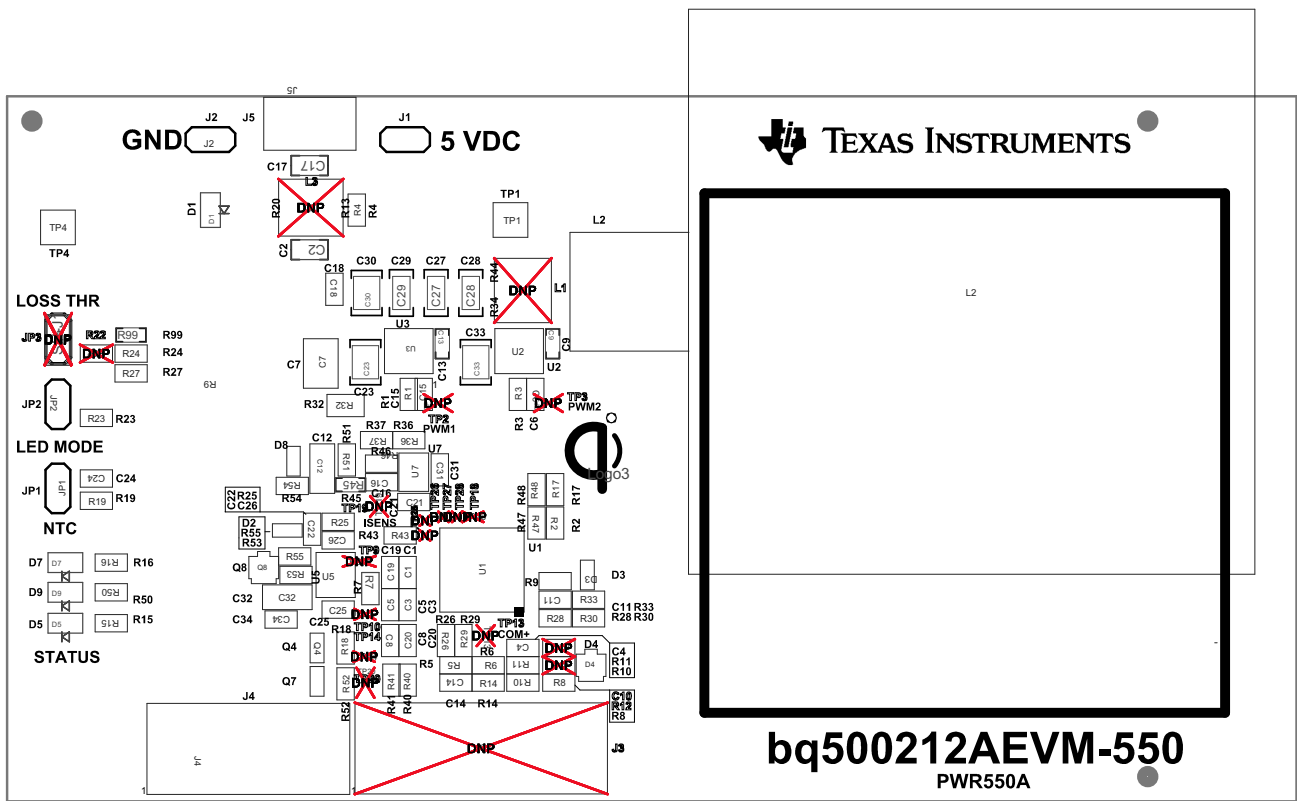

Figure 6. Assembly Top

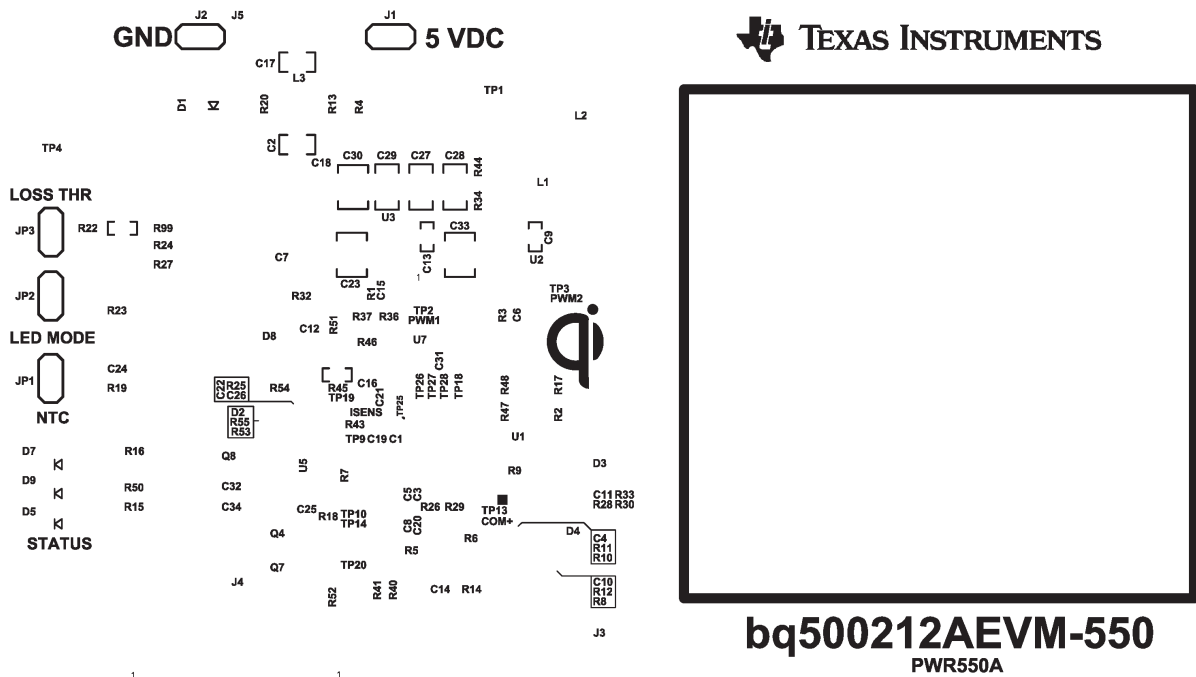

Figure 7. Top Silk

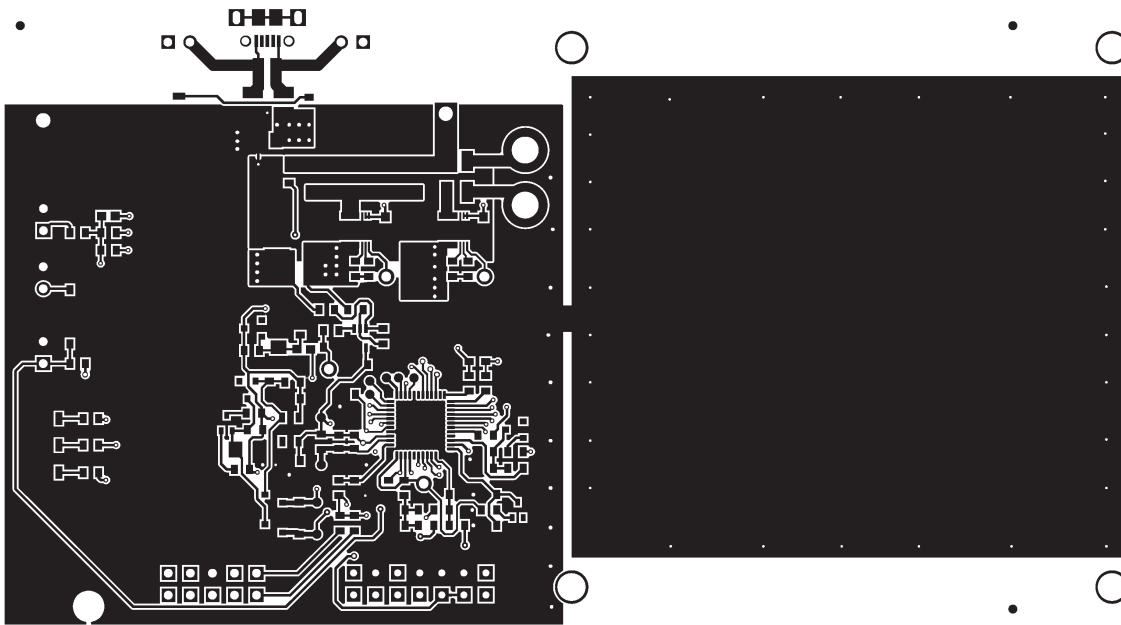

Figure 8. Top Layer

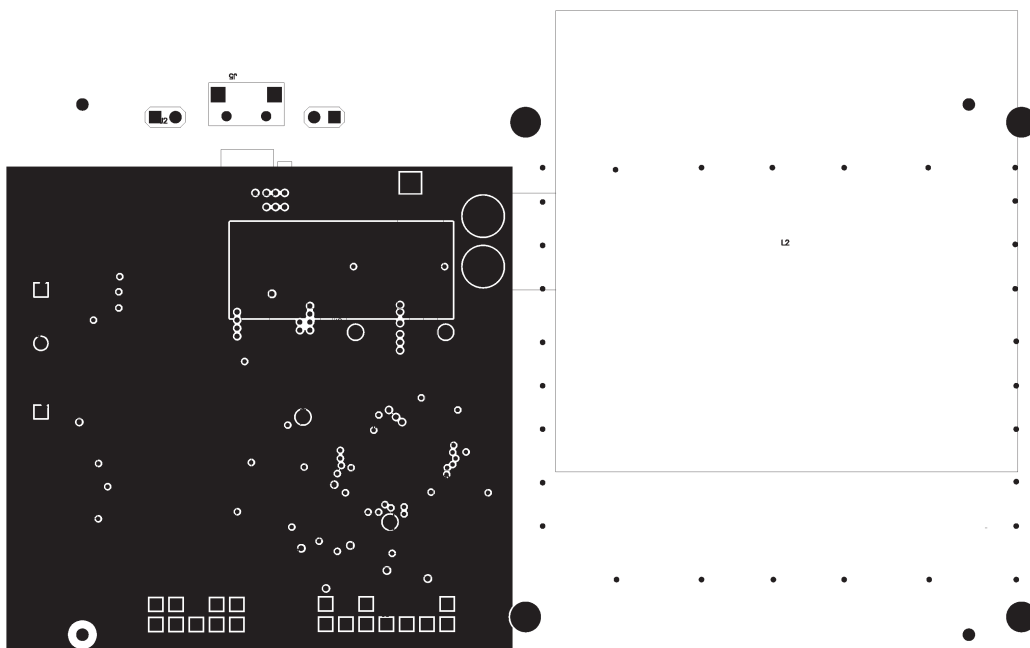

Figure 9. Layer 2

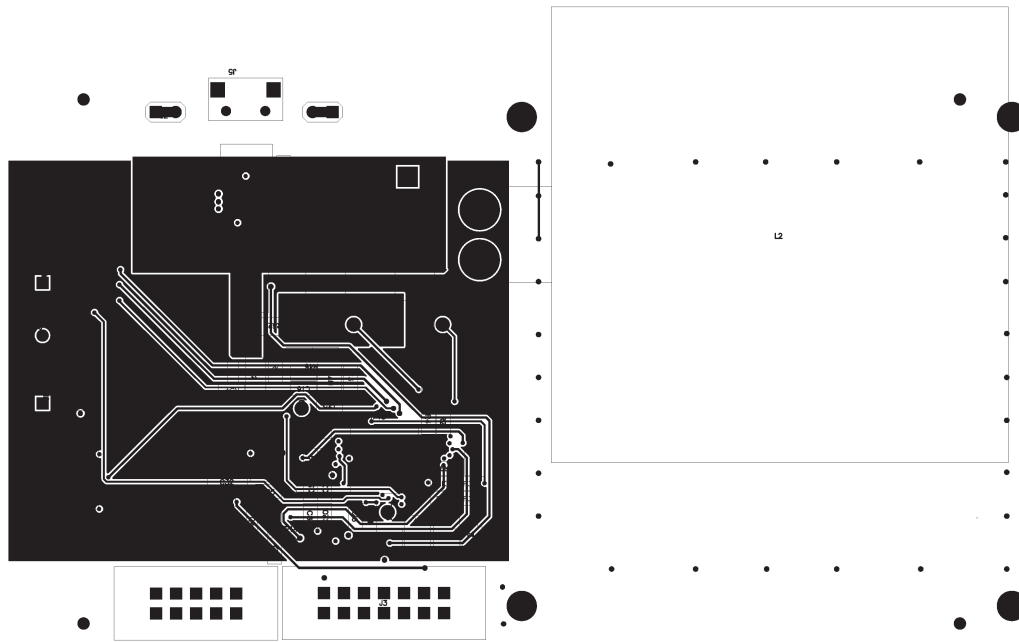

Figure 10. Layer 3

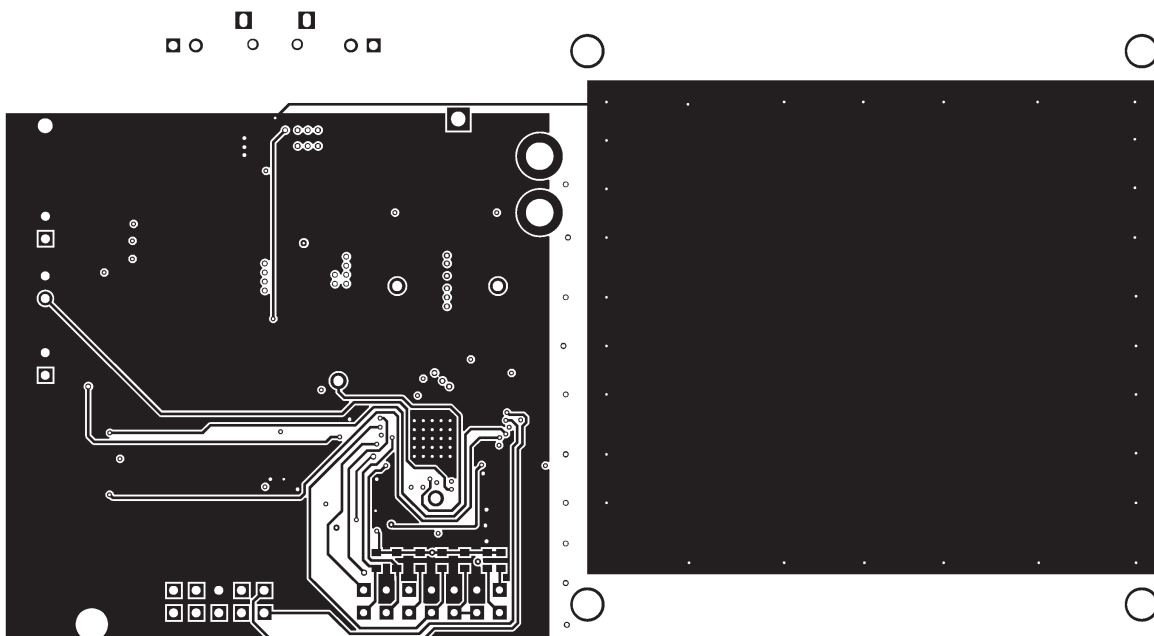

Figure 11. Bottom Layer

8 Reference

For additional information about the bq500212AEVM-550 low-power, wireless, power evaluation kit from Texas Instruments, visit the product folder on the TI Web site at <http://www.ti.com/product/bq500212A>

9 FCC and IC Regulatory Compliance

REGULATORY COMPLIANCE INFORMATION

As noted in the EVM User's Guide and/or EVM itself, this EVM is subject to the Federal Communications Commission (FCC), Industry Canada (IC) and European Union CE Mark rules.

FCC – FEDERAL COMMUNICATIONS COMMISSION Part 18 Compliant

Note: This equipment has been tested and found to comply with the limits for a Class B digital device, pursuant to part 18 of the FCC Rules. These limits are designed to provide reasonable protection against harmful interference in a residential installation. This equipment generates, uses and can radiate radio frequency energy and, if not installed and used in accordance with the instructions, may cause harmful interference to radio communications. However, there is no guarantee that interference will not occur in a particular installation. If this equipment does cause harmful interference to radio or television reception, which can be determined by turning the equipment off and on, the user is encouraged to try to correct the interference by one or more of the following measures:—Reorient or relocate the receiving antenna.

- Increase the separation between the equipment and receiver.
- Connect the equipment into an outlet on a circuit different from that to which the receiver is connected.
- Consult the dealer or an experienced radio/TV technician for help.

Note: There is no required maintenance of this device from a FCC compliance perspective.

IC – INDUSTRY CANADA ICES-001 Compliant

This ISM device complies with Canadian ICES-001.

Cet appareil ISM est conforme à la norme NMB-001 du Canada.

EVALUATION BOARD/KIT/MODULE (EVM) ADDITIONAL TERMS

Texas Instruments (TI) provides the enclosed Evaluation Board/Kit/Module (EVM) under the following conditions:

The user assumes all responsibility and liability for proper and safe handling of the goods. Further, the user indemnifies TI from all claims arising from the handling or use of the goods.

Should this evaluation board/kit not meet the specifications indicated in the User's Guide, the board/kit may be returned within 30 days from the date of delivery for a full refund. THE FOREGOING LIMITED WARRANTY IS THE EXCLUSIVE WARRANTY MADE BY SELLER TO BUYER AND IS IN LIEU OF ALL OTHER WARRANTIES, EXPRESSED, IMPLIED, OR STATUTORY, INCLUDING ANY WARRANTY OF MERCHANTABILITY OR FITNESS FOR ANY PARTICULAR PURPOSE. EXCEPT TO THE EXTENT OF THE INDEMNITY SET FORTH ABOVE, NEITHER PARTY SHALL BE LIABLE TO THE OTHER FOR ANY INDIRECT, SPECIAL, INCIDENTAL, OR CONSEQUENTIAL DAMAGES.

Please read the User's Guide and, specifically, the Warnings and Restrictions notice in the User's Guide prior to handling the product. This notice contains important safety information about temperatures and voltages. For additional information on TI's environmental and/or safety programs, please visit www.ti.com/esh or contact TI.

No license is granted under any patent right or other intellectual property right of TI covering or relating to any machine, process, or combination in which such TI products or services might be or are used. TI currently deals with a variety of customers for products, and therefore our arrangement with the user is not exclusive. TI assumes no liability for applications assistance, customer product design, software performance, or infringement of patents or services described herein.

REGULATORY COMPLIANCE INFORMATION

As noted in the EVM User's Guide and/or EVM itself, this EVM and/or accompanying hardware may or may not be subject to the Federal Communications Commission (FCC) and Industry Canada (IC) rules.

For EVMs **not** subject to the above rules, this evaluation board/kit/module is intended for use for ENGINEERING DEVELOPMENT, DEMONSTRATION OR EVALUATION PURPOSES ONLY and is not considered by TI to be a finished end product fit for general consumer use. It generates, uses, and can radiate radio frequency energy and has not been tested for compliance with the limits of computing devices pursuant to part 15 of FCC or ICES-003 rules, which are designed to provide reasonable protection against radio frequency interference. Operation of the equipment may cause interference with radio communications, in which case the user at his own expense will be required to take whatever measures may be required to correct this interference.

General Statement for EVMs including a radio

User Power/Frequency Use Obligations: This radio is intended for development/professional use only in legally allocated frequency and power limits. Any use of radio frequencies and/or power availability of this EVM and its development application(s) must comply with local laws governing radio spectrum allocation and power limits for this evaluation module. It is the user's sole responsibility to only operate this radio in legally acceptable frequency space and within legally mandated power limitations. Any exceptions to this are strictly prohibited and unauthorized by Texas Instruments unless user has obtained appropriate experimental/development licenses from local regulatory authorities, which is responsibility of user including its acceptable authorization.

For EVMs annotated as FCC – FEDERAL COMMUNICATIONS COMMISSION Part 15 Compliant

Caution

This device complies with part 15 of the FCC Rules. Operation is subject to the following two conditions: (1) This device may not cause harmful interference, and (2) this device must accept any interference received, including interference that may cause undesired operation.

Changes or modifications not expressly approved by the party responsible for compliance could void the user's authority to operate the equipment.

FCC Interference Statement for Class A EVM devices

This equipment has been tested and found to comply with the limits for a Class A digital device, pursuant to part 15 of the FCC Rules. These limits are designed to provide reasonable protection against harmful interference when the equipment is operated in a commercial environment. This equipment generates, uses, and can radiate radio frequency energy and, if not installed and used in accordance with the instruction manual, may cause harmful interference to radio communications. Operation of this equipment in a residential area is likely to cause harmful interference in which case the user will be required to correct the interference at his own expense.

FCC Interference Statement for Class B EVM devices

This equipment has been tested and found to comply with the limits for a Class B digital device, pursuant to part 15 of the FCC Rules. These limits are designed to provide reasonable protection against harmful interference in a residential installation. This equipment generates, uses and can radiate radio frequency energy and, if not installed and used in accordance with the instructions, may cause harmful interference to radio communications. However, there is no guarantee that interference will not occur in a particular installation. If this equipment does cause harmful interference to radio or television reception, which can be determined by turning the equipment off and on, the user is encouraged to try to correct the interference by one or more of the following measures:

- Reorient or relocate the receiving antenna.
- Increase the separation between the equipment and receiver.
- Connect the equipment into an outlet on a circuit different from that to which the receiver is connected.
- Consult the dealer or an experienced radio/TV technician for help.

For EVMs annotated as IC – INDUSTRY CANADA Compliant

This Class A or B digital apparatus complies with Canadian ICES-003.

Changes or modifications not expressly approved by the party responsible for compliance could void the user's authority to operate the equipment.

Concerning EVMs including radio transmitters

This device complies with Industry Canada licence-exempt RSS standard(s). Operation is subject to the following two conditions: (1) this device may not cause interference, and (2) this device must accept any interference, including interference that may cause undesired operation of the device.

Concerning EVMs including detachable antennas

Under Industry Canada regulations, this radio transmitter may only operate using an antenna of a type and maximum (or lesser) gain approved for the transmitter by Industry Canada. To reduce potential radio interference to other users, the antenna type and its gain should be so chosen that the equivalent isotropically radiated power (e.i.r.p.) is not more than that necessary for successful communication.

This radio transmitter has been approved by Industry Canada to operate with the antenna types listed in the user guide with the maximum permissible gain and required antenna impedance for each antenna type indicated. Antenna types not included in this list, having a gain greater than the maximum gain indicated for that type, are strictly prohibited for use with this device.

Cet appareil numérique de la classe A ou B est conforme à la norme NMB-003 du Canada.

Les changements ou les modifications pas expressément approuvés par la partie responsable de la conformité ont pu vider l'autorité de l'utilisateur pour actionner l'équipement.

Concernant les EVMs avec appareils radio

Le présent appareil est conforme aux CNR d'Industrie Canada applicables aux appareils radio exempts de licence. L'exploitation est autorisée aux deux conditions suivantes : (1) l'appareil ne doit pas produire de brouillage, et (2) l'utilisateur de l'appareil doit accepter tout brouillage radioélectrique subi, même si le brouillage est susceptible d'en compromettre le fonctionnement.

Concernant les EVMs avec antennes détachables

Conformément à la réglementation d'Industrie Canada, le présent émetteur radio peut fonctionner avec une antenne d'un type et d'un gain maximal (ou inférieur) approuvé pour l'émetteur par Industrie Canada. Dans le but de réduire les risques de brouillage radioélectrique à l'intention des autres utilisateurs, il faut choisir le type d'antenne et son gain de sorte que la puissance isotrope rayonnée équivalente (p.i.r.e.) ne dépasse pas l'intensité nécessaire à l'établissement d'une communication satisfaisante.

Le présent émetteur radio a été approuvé par Industrie Canada pour fonctionner avec les types d'antenne énumérés dans le manuel d'usage et ayant un gain admissible maximal et l'impédance requise pour chaque type d'antenne. Les types d'antenne non inclus dans cette liste, ou dont le gain est supérieur au gain maximal indiqué, sont strictement interdits pour l'exploitation de l'émetteur.

【Important Notice for Users of EVMs for RF Products in Japan】

This development kit is NOT certified as Confirming to Technical Regulations of Radio Law of Japan

If you use this product in Japan, you are required by Radio Law of Japan to follow the instructions below with respect to this product:

1. Use this product in a shielded room or any other test facility as defined in the notification #173 issued by Ministry of Internal Affairs and Communications on March 28, 2006, based on Sub-section 1.1 of Article 6 of the Ministry's Rule for Enforcement of Radio Law of Japan,
2. Use this product only after you obtained the license of Test Radio Station as provided in Radio Law of Japan with respect to this product, or
3. Use of this product only after you obtained the Technical Regulations Conformity Certification as provided in Radio Law of Japan with respect to this product. Also, please do not transfer this product, unless you give the same notice above to the transferee. Please note that if you could not follow the instructions above, you will be subject to penalties of Radio Law of Japan.

Texas Instruments Japan Limited
(address) 24-1, Nishi-Shinjuku 6 chome, Shinjuku-ku, Tokyo, Japan

<http://www.tij.co.jp>

【無線電波を送信する製品の開発キットをお使いになる際の注意事項】

本開発キットは技術基準適合証明を受けておりません。

本製品のご使用に際しては、電波法遵守のため、以下のいずれかの措置を取っていただく必要がありますのでご注意ください。

1. 電波法施行規則第6条第1項第1号に基づく平成18年3月28日総務省告示第173号で定められた電波暗室等の試験設備でご使用いただく。
2. 実験局の免許を取得後ご使用いただく。
3. 技術基準適合証明を取得後ご使用いただく。

なお、本製品は、上記の「ご使用にあたっての注意」を譲渡先、移転先に通知しない限り、譲渡、移転できないものとします。

上記を遵守頂けない場合は、電波法の罰則が適用される可能性があることをご留意ください。

日本テキサス・インスツルメンツ株式会社
東京都新宿区西新宿 6 丁目 2 4 番 1 号
西新宿三井ビル

<http://www.tij.co.jp>

EVALUATION BOARD/KIT/MODULE (EVM) WARNINGS, RESTRICTIONS AND DISCLAIMERS

For Feasibility Evaluation Only, in Laboratory/Development Environments. Unless otherwise indicated, this EVM is not a finished electrical equipment and not intended for consumer use. It is intended solely for use for preliminary feasibility evaluation in laboratory/development environments by technically qualified electronics experts who are familiar with the dangers and application risks associated with handling electrical mechanical components, systems and subsystems. It should not be used as all or part of a finished end product.

Your Sole Responsibility and Risk. You acknowledge, represent and agree that:

1. You have unique knowledge concerning Federal, State and local regulatory requirements (including but not limited to Food and Drug Administration regulations, if applicable) which relate to your products and which relate to your use (and/or that of your employees, affiliates, contractors or designees) of the EVM for evaluation, testing and other purposes.
2. You have full and exclusive responsibility to assure the safety and compliance of your products with all such laws and other applicable regulatory requirements, and also to assure the safety of any activities to be conducted by you and/or your employees, affiliates, contractors or designees, using the EVM. Further, you are responsible to assure that any interfaces (electronic and/or mechanical) between the EVM and any human body are designed with suitable isolation and means to safely limit accessible leakage currents to minimize the risk of electrical shock hazard.
3. Since the EVM is not a completed product, it may not meet all applicable regulatory and safety compliance standards (such as UL, CSA, VDE, CE, RoHS and WEEE) which may normally be associated with similar items. You assume full responsibility to determine and/or assure compliance with any such standards and related certifications as may be applicable. You will employ reasonable safeguards to ensure that your use of the EVM will not result in any property damage, injury or death, even if the EVM should fail to perform as described or expected.
4. You will take care of proper disposal and recycling of the EVM's electronic components and packing materials.

Certain Instructions. It is important to operate this EVM within TI's recommended specifications and environmental considerations per the user guidelines. Exceeding the specified EVM ratings (including but not limited to input and output voltage, current, power, and environmental ranges) may cause property damage, personal injury or death. If there are questions concerning these ratings please contact a TI field representative prior to connecting interface electronics including input power and intended loads. Any loads applied outside of the specified output range may result in unintended and/or inaccurate operation and/or possible permanent damage to the EVM and/or interface electronics. Please consult the EVM User's Guide prior to connecting any load to the EVM output. If there is uncertainty as to the load specification, please contact a TI field representative. During normal operation, some circuit components may have case temperatures greater than 60°C as long as the input and output are maintained at a normal ambient operating temperature. These components include but are not limited to linear regulators, switching transistors, pass transistors, and current sense resistors which can be identified using the EVM schematic located in the EVM User's Guide. When placing measurement probes near these devices during normal operation, please be aware that these devices may be very warm to the touch. As with all electronic evaluation tools, only qualified personnel knowledgeable in electronic measurement and diagnostics normally found in development environments should use these EVMs.

Agreement to Defend, Indemnify and Hold Harmless. You agree to defend, indemnify and hold TI, its licensors and their representatives harmless from and against any and all claims, damages, losses, expenses, costs and liabilities (collectively, "Claims") arising out of or in connection with any use of the EVM that is not in accordance with the terms of the agreement. This obligation shall apply whether Claims arise under law of tort or contract or any other legal theory, and even if the EVM fails to perform as described or expected.

Safety-Critical or Life-Critical Applications. If you intend to evaluate the components for possible use in safety critical applications (such as life support) where a failure of the TI product would reasonably be expected to cause severe personal injury or death, such as devices which are classified as FDA Class III or similar classification, then you must specifically notify TI of such intent and enter into a separate Assurance and Indemnity Agreement.

Mailing Address: Texas Instruments, Post Office Box 655303, Dallas, Texas 75265
Copyright © 2013, Texas Instruments Incorporated

IMPORTANT NOTICE

Texas Instruments Incorporated and its subsidiaries (TI) reserve the right to make corrections, enhancements, improvements and other changes to its semiconductor products and services per JESD46, latest issue, and to discontinue any product or service per JESD48, latest issue. Buyers should obtain the latest relevant information before placing orders and should verify that such information is current and complete. All semiconductor products (also referred to herein as "components") are sold subject to TI's terms and conditions of sale supplied at the time of order acknowledgment.

TI warrants performance of its components to the specifications applicable at the time of sale, in accordance with the warranty in TI's terms and conditions of sale of semiconductor products. Testing and other quality control techniques are used to the extent TI deems necessary to support this warranty. Except where mandated by applicable law, testing of all parameters of each component is not necessarily performed.

TI assumes no liability for applications assistance or the design of Buyers' products. Buyers are responsible for their products and applications using TI components. To minimize the risks associated with Buyers' products and applications, Buyers should provide adequate design and operating safeguards.

TI does not warrant or represent that any license, either express or implied, is granted under any patent right, copyright, mask work right, or other intellectual property right relating to any combination, machine, or process in which TI components or services are used. Information published by TI regarding third-party products or services does not constitute a license to use such products or services or a warranty or endorsement thereof. Use of such information may require a license from a third party under the patents or other intellectual property of the third party, or a license from TI under the patents or other intellectual property of TI.

Reproduction of significant portions of TI information in TI data books or data sheets is permissible only if reproduction is without alteration and is accompanied by all associated warranties, conditions, limitations, and notices. TI is not responsible or liable for such altered documentation. Information of third parties may be subject to additional restrictions.

Resale of TI components or services with statements different from or beyond the parameters stated by TI for that component or service voids all express and any implied warranties for the associated TI component or service and is an unfair and deceptive business practice. TI is not responsible or liable for any such statements.

Buyer acknowledges and agrees that it is solely responsible for compliance with all legal, regulatory and safety-related requirements concerning its products, and any use of TI components in its applications, notwithstanding any applications-related information or support that may be provided by TI. Buyer represents and agrees that it has all the necessary expertise to create and implement safeguards which anticipate dangerous consequences of failures, monitor failures and their consequences, lessen the likelihood of failures that might cause harm and take appropriate remedial actions. Buyer will fully indemnify TI and its representatives against any damages arising out of the use of any TI components in safety-critical applications.

In some cases, TI components may be promoted specifically to facilitate safety-related applications. With such components, TI's goal is to help enable customers to design and create their own end-product solutions that meet applicable functional safety standards and requirements. Nonetheless, such components are subject to these terms.

No TI components are authorized for use in FDA Class III (or similar life-critical medical equipment) unless authorized officers of the parties have executed a special agreement specifically governing such use.

Only those TI components which TI has specifically designated as military grade or "enhanced plastic" are designed and intended for use in military/aerospace applications or environments. Buyer acknowledges and agrees that any military or aerospace use of TI components which have **not** been so designated is solely at the Buyer's risk, and that Buyer is solely responsible for compliance with all legal and regulatory requirements in connection with such use.

TI has specifically designated certain components as meeting ISO/TS16949 requirements, mainly for automotive use. In any case of use of non-designated products, TI will not be responsible for any failure to meet ISO/TS16949.

Products

Audio	www.ti.com/audio
Amplifiers	amplifier.ti.com
Data Converters	dataconverter.ti.com
DLP® Products	www.dlp.com
DSP	dsp.ti.com
Clocks and Timers	www.ti.com/clocks
Interface	interface.ti.com
Logic	logic.ti.com
Power Mgmt	power.ti.com
Microcontrollers	microcontroller.ti.com
RFID	www.ti-rfid.com
OMAP Applications Processors	www.ti.com/omap
Wireless Connectivity	www.ti.com/wirelessconnectivity

Applications

Automotive and Transportation	www.ti.com/automotive
Communications and Telecom	www.ti.com/communications
Computers and Peripherals	www.ti.com/computers
Consumer Electronics	www.ti.com/consumer-apps
Energy and Lighting	www.ti.com/energy
Industrial	www.ti.com/industrial
Medical	www.ti.com/medical
Security	www.ti.com/security
Space, Avionics and Defense	www.ti.com/space-avionics-defense
Video and Imaging	www.ti.com/video

TI E2E Community

e2e.ti.com