

EMIT

CRITICAL ENVIRONMENT (C/E) SERIES OVERHEAD IONIZER OWNER'S MANUAL



Made in the
United States of America

EMIT - 3651 Walnut Avenue, Chino, CA 91710 • (909) 664-9980 • Website: DescoEMIT.com

Description

Ionizers are useful in preventing electrostatic charge generation, ElectroStatic Discharge, ElectroStatic Attraction, as well as preventing equipment latch-up and safety related shock. ANSI/ESD S20.20 Paragraph 6.2.3.1 Protected Areas Requirement states: "Ionization or other charge mitigating techniques shall be used at the workstation to neutralize electrostatic fields on all process essential insulators if the electrostatic field is considered a threat." Ionization is used to neutralize charges on process necessary insulators and isolated semiconductors. Some examples of process necessary insulators are: the PC board itself, plastic test stands, plastic housing where a PCB may be mounted, as well as computer monitor screens and regular cleaning wipes. Examples of floating or isolated conductors are: loaded PCB mounted in a stand where the pins are not contacting the dissipative workstation. Ionization is not effective on items that have large capacitance, like people and carts; however, ionizers should be considered as a method for charge neutralization in cases where grounding cannot be achieved.

Air ionization can neutralize the static charge on insulated and isolated objects by producing separate charges in the molecules of the gases of the surrounding air. When an electrostatic charge is present on objects in the work environment, it will be neutralized by attracting opposite polarity charges from the ionized air. Note that ionization systems should not be used as a primary means of charge control on conductors or people. (Reference: IEC 61340-5-2:1 paragraph 5.2.9).

EMIT's Critical Environment overhead ionizers are NIST calibrated and are available in four models:

- [50606](#)
C/E Ionizer 24", 120 Volt
- [50607](#)
C/E Ionizer 48", 120 Volt
- [50608](#)
C/E Ionizer 24", 220 Volt
- [50609](#)
C/E Ionizer 48", 220 Volt

The [50606](#) and [50608](#) are 24" long units with 2 fans, and the [50607](#) and [50609](#) are 48" long units with 4 fans. All models have the same features permitting the user to select the best size for the application. Since our introduction of the first overhead ionizer in the market, we have continued to enhance our offerings with the most advanced features available.

IONIZER SELECTION

ANSI/ESD S20.20 paragraph 6.1.1.2. ESD Control Program Plan Guidance states: "The Plan should include a listing of the specific type of ESD protective materials and equipment used in the Program." When selecting an ionizer life cycle costs should be considered including: equipment cost; installation cost; and operation and maintenance cost.

The C/E series offers many design improvements, most notably, our patent-pending "Emitter Cassette" (see figure 1).

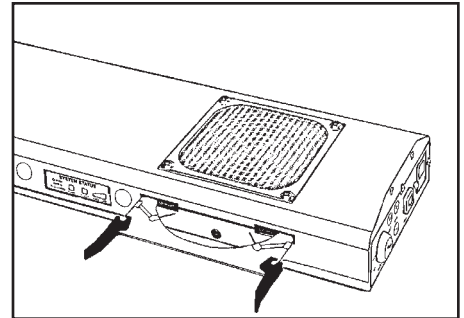

Figure 1. Removable emitter cassette

While other manufacturers attempt to simplify or automate the cleaning of the emitter pins, what remains is one major flaw in the process - unless the ionizer is removed to another area, the contamination ends up on the workstation and on any product that happens to be nearby.

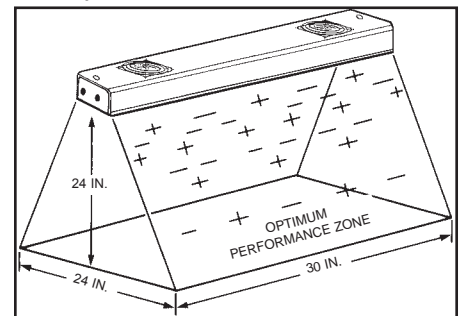

Figure 2. Area of optimum charge neutralization for [50606](#) and [50608](#)

*U.S. Patent #6,137,670

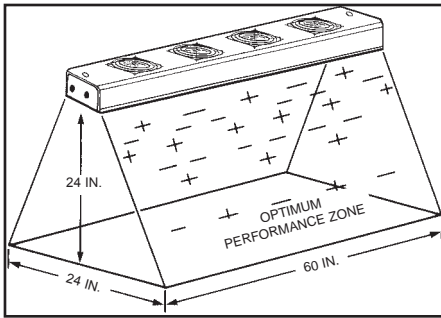

Figure 3. Area of optimum charge neutralization for [50607](#) and [50609](#)

The C/E series solves this problem. When the emitters need to be cleaned, the cassettes are easily removed from the unit and taken to another area to be cleaned. This takes the dirt away from the workstation and product. To eliminate downtime, a spare set of clean emitter cassettes can be dropped in. The others can be cleaned when convenient. This concept is so unique, that we have been awarded a patent on it.

Features

- Removable emitter cassettes allow you to minimize contamination of the work area.
- Closed-loop feedback electronic balance system continuously monitors output for optimal performance.
- I/O port allows auto- calibration and remote status monitoring.
- Sealed plenum chamber around each fan minimizes contamination.
- Non-volatile adjustments for balance and fan speed are maintained in the absence of power.

- Lockout key with distinctive front panel indicator prevents unauthorized adjustment.
- Balance is individually adjustable at each fan zone.
- Flashing front panel signal indicates when cleaning is needed.
- IEC input and output connectors allow daisy-chaining of up to 2 units.
- Stainless steel and powder-coated aluminum construction for durability and long life.

Specifications

Input Power:

- 120VAC, 250mA, 24" model
- 120VAC, 400mA, 48" model
- 220VAC, 250mA, 24" model
- 220VAC, 400mA, 48" model

IEC Outlet:

Allows a second unit to be daisy-chained

Fuse:

5x20mm 3 amp time lag

Air Flow:

- 80-170 CFM, 24" model
- 160-340 CFM, 48" model

Emitters:

100% Tungsten, replaceable

Ionization Type:

Steady-state DC

Balance:

0±10 volts at set-up at 24" above charged plate analyzer

Weight:

6.2 lbs. (24" model)
11.1 lbs. (48" model)

Size:

2" x 6" x 24"
2" x 6" x 48"

Mounting:

(2) 1/4" mounting holes each end

Installation

EMIT's C/E ionizer is designed to mount above the work area, providing even coverage without using valuable work surface area. Mounting is a matter of personal preference, and may be accomplished with brackets attached to a shelf, or the unit may be suspended by chain. Whatever method is used, care should be taken to insure that the mounting is secure and capable of supporting the weight of the unit. The power cord should be supported as well to provide protection against any hazard to the operator.

"S" hooks are provided with each unit to facilitate mounting using the chain suspension method. The ideal mounting height is 24" above the work surface, although the ionizer may be located slightly higher or lower if required. For maximum performance, care should be taken to insure that the intake grills for the fans are not obstructed.

Turn the power key switch to the "OFF" position. Plug the IEC end

of the cord into the ionizer and the other end into a properly wired outlet. We recommend that the outlet used by the ionizer be tested before use and periodically checked for correct wiring and a good solid ground. The C/E ionizer depends on a good ground for proper balancing.

Safety interlock switches are provided internally on each emitter cassette. This ensures that power is cut off in the event that any cassette is removed or not fully installed.

The grills below each fan function as sensors and feed back a signal to the balance circuitry. Therefore, it is important not to hang or attach anything to the fan grills.

Controls and Functions

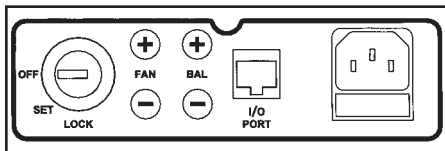

Figure 4. Control Panel

• The **CONTROL PANEL** is located on the right hand end of the ionizer. It provides controls for fan speed, balance, and a key switch to prevent unauthorized adjustment of the controls. Also located on the control panel is an I/O port that may be used for auto calibration. It also is used to provide output signals to

allow remote monitoring of ionizer status.

• **OFF / SET/LOCK** key switch - this switch controls the power to the ionizer. When the SET position is selected, it allows the balance and fan speed to be adjusted. When the LOCK position is selected, a LOCK indicator is illuminated on the front panel of the ionizer. In this position, the balance and fan speed controls are disabled and the key is removable. In the OFF position, power is shut off to the ionizer and the key is removable.

• **FAN** speed adjustment switches are used to set the fan speed to the desired level that provides the best performance while minimizing operator discomfort. With the key switch in the SET position, pressing and holding the “+” symbol will increase fan speed, and the “-” symbol will decrease fan speed. Relative fan speed is displayed on the front panel indicator.

• **BAL** controls are used to adjust the balance of the ionizer and are used in conjunction with a charged plate analyzer. Pressing the “+” symbol will shift the balance offset positive, while pressing the “-” symbol will shift it negative. Adjustment should be made with a charged plate analyzer located 24”

directly under the ionizer. The BAL controls, like the FAN speed, are only adjustable when the key switch is in the SET position.

• **I/O PORT** serves a dual purpose. It accepts signals from a charged plate analyzer and automatically calibrates the ionizer when the key switch is in the SET position. It also outputs ionizer status signals that can be useful for remote monitoring.

• **IEC INPUT CONNECTOR**, based on the International IEC 60320 Standard, allows the power to be disconnected at the ionizer and provides a fuse drawer for a 5mm x 20mm fuse. The fuse drawer may be opened when the cordset is removed. In addition, an IEC Outlet on the opposite end of the ionizer can supply power for a charged plate analyzer, or for up daisy-chaining a second unit.

Front Panel Display and Controls

See figure 5.

System Status is the information center on the front of the ionizer. From it, the operator can easily check the operational status of the ionizer.

• **PWR** - this indicator will normally be green when the ionizer is

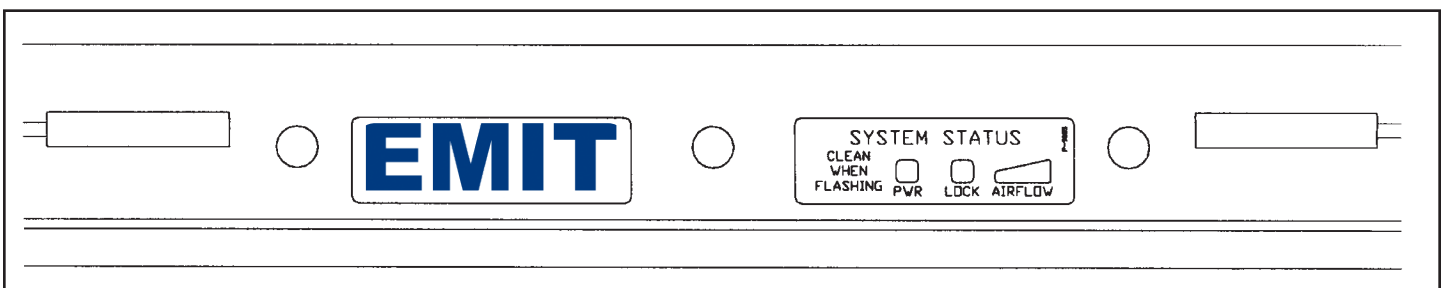

Figure 5. Front panel and controls

operating correctly. When the autobalance circuit can no longer adjust for dirty emitter pins, this indicator will turn red and begin to flash. It is normal for it to flash for a few seconds each time the ionizer is turned on. This indicator will be on when the key switch is either in the "SET" or "LOCK" position.

- **LOCK** - when the key switch on the end of the ionizer is set to lock, this indicator will display a distinctive blue light. This makes it readily apparent that the ionizer has its settings locked, preventing unauthorized adjustment.
- **AIRFLOW** - this display indicates relative airflow output from the fans. If the key switch is in the "SET" position and the "+" or "-" button are pressed and held, the fan speed will increase or decrease with a corresponding change in the AIRFLOW display. As fan speed is increased, the display will move to the right.
- **MINOR ADJUSTMENTS ACCESS** - each fan zone may be balanced separately. The adjustments are designed for minor corrections to balance one fan to another. Overall balance adjustments should be done with the "BAL" switches on the end panel.
- **VR6, VR5, VR2, and VR1** - are the zone balance adjustments for the zones 1 through 4 respectively. Zone 1 is closest to the right end. 24" models will only have VR6 and VR5 adjustments. These adjustments are covered in the section titled "Calibration Instructions".
- **VR3 and VR4** - are adjustments to

center the alarm and to change the alarm sensitivity. These adjustments are covered in the section titled "Calibration Instructions".

- **ALARM SWITCH** - this switch provides an audible alarm to supplement the flashing red PWR light when the unit needs cleaning.

Operation

After the unit is mounted securely and connected to a properly wired outlet, turn the key switch to the set position. The performance of the ionizer is directly related to the airflow on the area to be protected. Generally, try to use the highest setting possible without disturbing the operator or the work in process.

After allowing the unit to run for several minutes, a charged plate analyzer can be used to check the balance and performance. We recommend doing this at the time of the initial installation, so that data can be collected and saved for future reference. Place the charged plate analyzer directly under each fan and record the float (balance) voltage. If all fans are offset slightly in the same direction, the "+" or "-" BAL buttons can be used to correct the offset. If the balance varies from a positive offset to a negative offset between fans, the individual fan zone controls can be touched up slightly as required.

It is not uncommon to find differences between ionizers from bench to bench or even between fans on ionizers during initial setup. This is often caused by the presence of objects on or around the bench. Large metal objects

nearby or machines or equipment on the bench will often cause a shift in the offset voltage at that area. The individual zone controls of the C/E ionizers allow this to be compensated for during initial setup.

After balance offsets have been checked, the decay performance of each fan should be measured and recorded. This information will be useful to establish a maintenance schedule. When decay times begin to increase significantly, or if the red PWR light begins to flash, emitter cleaning is usually indicated. By recording the time intervals between the first few cleanings, a maintenance schedule can be developed. After initial setup and testing has been done, the key switch can be set to the LOCK position and normal workstation use resumed.

If the ionizer is used in a manner not specified by the manufacturer, the protection provided by the ionizer may be impaired.

Maintenance

"As with all ionizers, periodic maintenance will be needed to provide optimum performance." (Reference: IEC 61340-5-2:1 paragraph 5.2.9).

The frequency of monitoring ionizers really depends on how and where they are used. Since the majority of them use a fan to transport the ions to the working area, the cleanliness of the air directly affects their performance over time and how often the emitters should be cleaned.

EIA-625 recommends checking ionizers every 6 months, but this may not be suitable for many programs particularly since an out-of-balance may exist for months before it is checked again. ANSI/ESD S20.20 paragraph 6.1.3.1 Compliance Verification Plan Requirement states: "Test equipment shall be selected to make measurements of appropriate properties of the technical requirements that are incorporated into the ESD program plan." And paragraph 6.1.3.2. Compliance Verification Plan Guidance states: "In addition to internal audits, external audits (Organization and supplier of ESDS items) should be performed to ensure compliance with planned requirements. Verifications should include routine checks of the Technical Requirements in the Plan. The frequency of verification checks should be based on the control item usage, its durability and associated risk of failure."

Under normal conditions the ionizer will attract dirt and dust (especially on the emitter and fan guards). To maintain optimum

performance, cleaning must be done on a regular basis. The electrodes should be cleaned at least every 6 months. However, more frequent cleaning may be required if used in environments with more contaminants.

This was a major factor in the design process of the C/E ionizer. The Replacement Emitter Cassette can be removed to another area, and the emitters are then very accessible. Although we could not eliminate the maintenance, we have made it far easier and much cleaner than ever before.

- Turn the key switch to the OFF position.
- Grasp the Replaceable Emitter Cassette ejector levers at the center and pivot outward about 90 degrees.
- Grasping the right and left corners, pull the Replaceable Emitter Cassette straight out of the ionizer.
- The Replaceable Emitter Cassettes can then be replaced with a spare cassette or removed to another area for cleaning.
- Cleaning of the Replaceable

Emitter Cassette can be accomplished with a stiff brush or lint-free swab and isopropyl alcohol or other residue-free cleaning solvent.

- The Replaceable Emitter Cassettes or the individual removable tungsten emitters can also be cleaned in an ultrasonic cleaning tank.

Calibration

See figure 6.

Equipment and tools used:

- CE Ionizer
- CPA (Charged Plate Analyzer)
- Adjustment Tool for Potentiometers
- Auto-Cal (if Auto-cal is used)

Set-up:

1. Make sure worksurface and technician is properly grounded
2. Ionizer needs to be at least 18" and no more than 24" from worksurface.
3. Make sure power outlet is properly wired and there is no voltage in the neutral line.

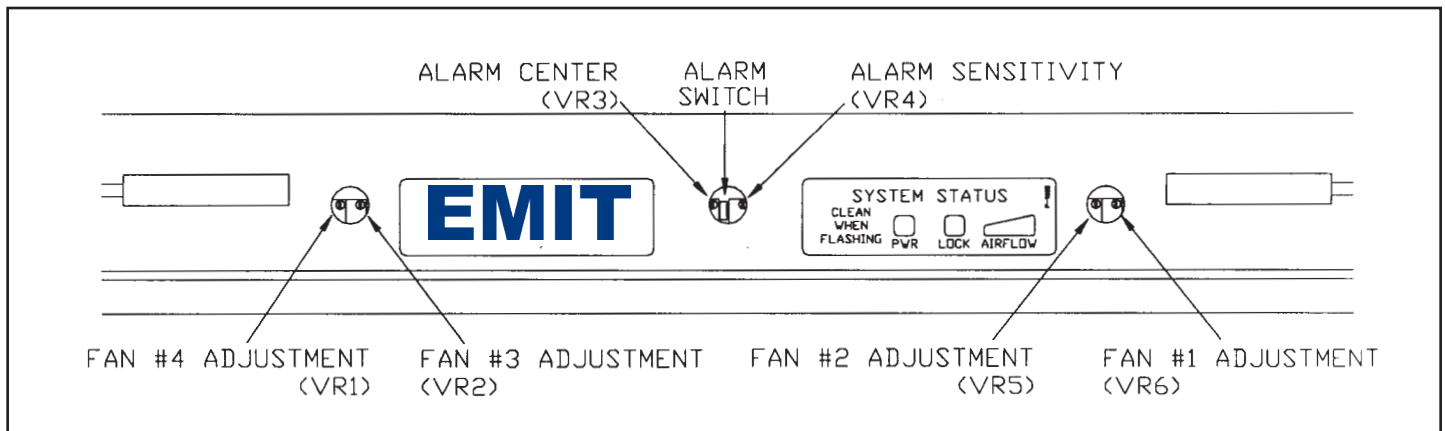

Figure 6. Calibrating C/E Ionizer

- CPA needs to sit directly under one fan on the ionizer, any fan will do. **BE SURE CPA HAS BEEN RESET TO ZERO (REFER TO CPA MANUAL ON HOW TO ZERO CPA PLATE)**

Calibrating Ionizer:

- Power up CE ionizer and set key to "SET" position.
- Hold down "+" on the fan speed button on the side of CE ionizer to bring fan speed to the maximum speed setting, airflow LED in front of unit should be fully lit (lighting up from left to right LED)
- Make sure CPA plate is directly under one of the ionizer's fan.
- Hold down "+" on the balance button located on the side of the ionizer. Record the highest positive reading and record on piece of paper. Hold down "-" on the balance button and record the highest negative reading. Use the formula below to calculate where the balance needs to be set, before adjusting any of the VR. Once calculation is completed and let's say your final balance is -15V, press balancing buttons on the side of the ionizer to get -15V on CPA reading.

$$(A + B) / 2 = C$$

A = highest positive reading
 B = highest negative reading
 C = center balance of ionizer

- Remove white caps located in the front of the ionizer.

EXAMPLES:	
50V on positive	10V on positive
-80V on negative	-100V on negative
$(50 \pm 80) / 2 = C$	$(10 \pm 100) / 2 = C$
$(-30) / 2 = C$	$(-90) / 2 = C$
-15 = C	-45 = C

- See figure 6. For VR (variable resistor) locations. Fans from right to left side are labeled 1 to 4. VR from right to left side are labeled 6, 5, 2 and 1. So if you have the CPA under fan 1, you are going to adjust VR6. Adjust VR6 so balance on CPA reads 0Volts @ +/-15Volts. Move the CPA from fan 1 to next fan, fan 2 and adjust VR5 to 0Volts @ +/-15Volts, repeat these set for all fans. All fans should be at 0Volts @ +/- 15Volts.
- Have CPA under fan 1 and charge CPA to +1000Volts and test the decay time. Unit should decay under 5secs @ 18" from grill of unit to plate of CPA. Charge CPA to -1000Volts and test the decay time. Unit should decay under 5secs @ 18" from grill of unit to plate of CPA. Do this for all fans.

Ionizer that is over 18" will have a slightly higher decay time.

Adjust Alarm Setting:

- Turn VR3 counter clockwise to where the alarm starts or when the status LED turns "RED". While turning VR3 clockwise count how many turns until unit starts alarming again. Divide that number of turns in half and subtract 3.5 turns to give you the number of turns you need to turn VR3 counter clockwise. Now turn VR4 counter clockwise to where the alarm starts or when the status LED turns "RED". Now turn VR3 3.5 turns counter clockwise and alarm is now set.

Auto-Calibration Unit Adjustment:

- Have CPA plate directly under one of the fan of ionizer plus auto-cal next to it. **BE SURE CPA HAS BEEN RESET TO ZERO (REFER TO CPA MANUAL ON HOW TO ZERO CPA PLATE)**
- Observe balance reading on CPA.
- Under the ionizer to the right side, there is a hole where the VR for the auto-calibration system is located. Turn the VR slowly clockwise or counter clockwise to zero out the balance of the auto-cal system. Be sure to give the auto cal 30sec for it to adjust itself every time VR has been adjusted.

4. Move the CPA plate and auto-cal to the next fan, balance should be at 0Volts @ +/-15Volts.
5. Note, adjusting VR for auto-cal system will affect all fans on the ionizer. Repeat step 4 until unit is balancing at 0Volts @ +/-15Volts with auto-calibration unit.

Warning! Do not attempt to calibrate this unit without proper equipment such as a charged plate analyzer. Adjustments to the calibration controls should be performed by authorized trained personnel only.

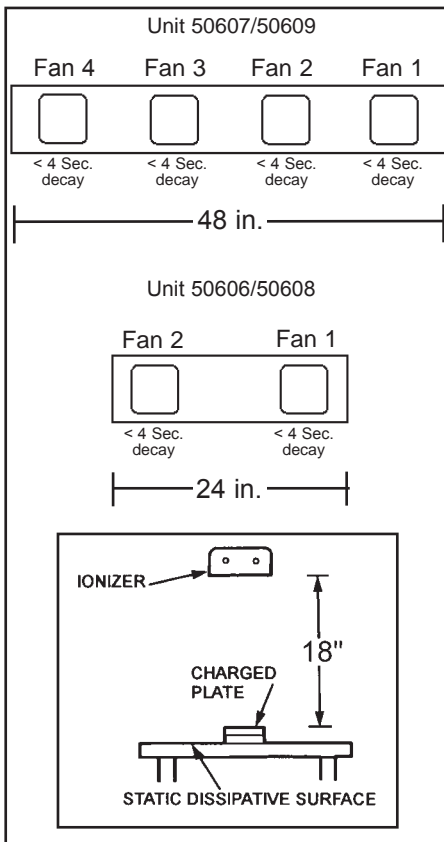

Figure 7. Balance under < 10 volts. When set under lab conditions, 5 volts is attainable.

Balance Adjustment

Using a charge plate analyzer, check each fan's balance. Use the "BAL" switches to zero the unit. If the fans are a little out of balance with each other use the fan adjustment pots to equalize them. VR5,6 and VR1,2 on 48" model.

NOTE: Each fan has its own balance circuit, however the alarm circuits tie them together. If one or more of the individual fan balance circuits are offset too much from the rest it could cause the alarm not to function correctly. If more than a slight amount of adjustment is required at any individual fan zone, we recommend that the unit be reset using the "Major Reset Adjustment" instructions below.

Major Reset Adjustments - Use this procedure only if the "Balance adjustment" above does not permit proper operation.

1. Turn key to "SET" position.
2. The potentiometers in this unit have a 24-turn range. Reset all of them by turning them at least 24 revolutions counter-clockwise.
3. Set the fan adjustment pots (VR1, VR2, VR5 and VR6) to center by turning them 12 revolutions clockwise.
4. Center the "BAL" control found on the control panel on the right end of the ionizer using the following process. Place a charged plate analyzer under any of the fans, push and hold the "+" BAL switch to find its most positive point, use the "-" BAL switch to find its

most negative point, calculate the midpoint and set the balance using the "BAL" buttons to that point. Example: if the most positive point is +40V and its most negative point is -10V, you would set the balance to $\pm 15V$.

5. Adjust each fan's output by placing the charged plate analyzer underneath it and using its corresponding potentiometer to zero its balance. Turn clockwise for more positive and counter clockwise for more negative.
6. Turn alarm sensitivity (VR4) 3 revolutions clockwise. Alarm center (VR3) should be turned clockwise until "PWR" light turns green. VR3 should have two full revolutions in which the "PWR" light remains green. If VR3 doesn't have two full revolutions of green turn VR4 clockwise one turn and check again. If VR3 has a lot more than two full revolutions of green turn VR4 counter clockwise and check again. Finish by setting VR3 to the midpoint of green range.

Health

There are no known health risks associated with our devices. The emitters work at about 4-6 kV and can create ozone, but there have been no significant measurement of ozone from our emitter sets, as all our existing units test well below the OSHA limit of 0.05 ppm ozone. For additional safety information, see "Dispelling an Old Myth" written by William Metz of Hewlett-Packard published in *Evaluation Engineering* magazine, September 2001.

TROUBLESHOOTING CHART

PROBLEM	POSSIBLE CAUSE	SOLUTION
Unit won't turn on	Key is on "off" position.	Turn key to "SET" or "LOCK" position.
	One or more emitter cassettes are not fully inserted.	Push in emitter cassette(s) completely.
	No Power	Check power cord or fuse.
Fan speed or Balance won't adjust	Key is in "Lock " Position (Blue indicator On).	Turn key to "Set" Position.
	Button depressed too quickly, or pressed too lightly.	Push and hold buttons firmly.
"PWR" light is flashing red.	Emitter pins are dirty or contaminated.	Remove emitter cassette and clean emitters.
"PWR" light is flashing after emitter cassettes have been cleaned.	Unit is out of calibration.	Refer to pages 6 and 7 for calibration instructions.
There is no audible alarm when "PWR" light is flashing red.	Alarm switch is set to off.	Refer to page 5 and 6 for switch location.

Limited Warranty, Warranty Exclusions, Limit of Liability and RMA Request Instructions

See EMIT's Warranty -

<http://emit.descoindustries.com/Warranty.aspx>