

AN-1348 LM3670 Evaluation Board

1 Introduction

The LM3670 evaluation board is a working demonstration of a step-down DC-DC converter. This document contains information about the evaluation board. For further information on buck converter topology, device electrical characteristics, and component selection please refer to the data sheet.

2 General Description

The LM3670 converts high input voltages to lower output voltages with high efficiency through an inductor based switching topology. Automatic intelligent switching between PWM low-noise and PFM low-current mode offers improved system control. LM3670 is available in both fixed output voltage options (1.2V, 1.5V, 1.6V, 1.8V, 1.875V, 2.5V, 3.3V) and adjustable voltage options range from 0.7V to 2.5V. The LM3670 is available in a SOT23-5 package.

3 Operating Conditions

- V_{IN} range: $2.5V \leq V_{IN} \leq 5.5V$
- Recommended load current: $0\text{ mA} \leq I_{OUT} \leq 350\text{ mA}$
- Ambient temperature (T_A) range: $-40C$ to $+85C$
- Junction temperature (T_J) range: $-40C$ to $+125C$

4 Typical Application

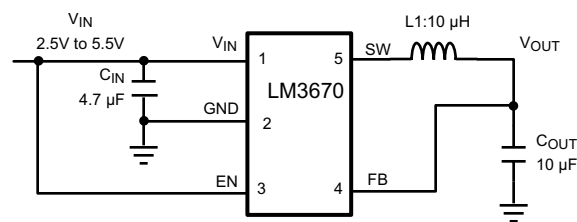

Figure 1. Fixed Output Voltage--Typical Application Circuit

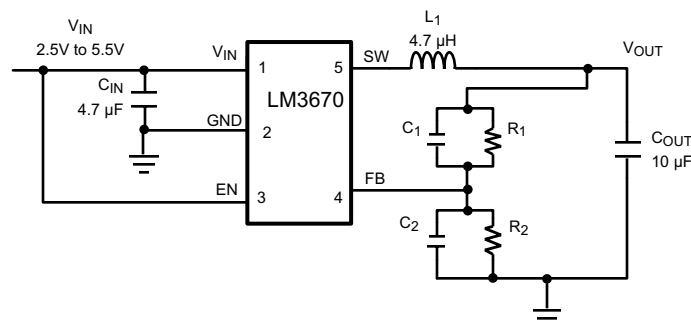

Figure 2. Adjustable Output Voltage—Typical Application Circuit

All trademarks are the property of their respective owners.

5 Output Voltage Selection for LM3670MF-ADJ

The output voltage of the adjustable parts can be programmed through the resistor network connected from V_{OUT} to V_{FB} to GND. The resistor from V_{FB} to GND (R_2) should be at least 100k Ω to keep the current sunk through this network well below 15 μ A quiescent current level (PFM mode with no switching) but large enough that it is not susceptible to noise. If R_2 is 200k Ω , and given the V_{FB} is 0.5V, then the current through the resistor feedback network will be 2.5 μ A ($I_{FB} = 0.5V/R_2$). The output voltage formula is:

$$V_{OUT} = V_{FB} \left(\frac{R_1}{R_2} + 1 \right) \quad (1)$$

V_{OUT} : output voltage (V)

V_{FB} : feedback voltage (0.5V typical)

R_1 : feedback resistor from V_{OUT} to V_{FB} (Ω)

R_2 : feedback resistor from V_{FB} to GND (Ω)

For the fixed output voltage parts the feedback resistors are internal and R_1 is 0 Ω .

The bypass capacitors C_1 and C_2 (labeled C_4 and C_5 on Evaluation Board) in parallel with the feedback resistors are chosen for increased stability. Below are the formulas for C_1 and C_2 .

$$C_1 = \frac{1}{2 * \pi * R_1 * 10 \text{ kHz}} \quad (2)$$

$$C_2 = \frac{1}{2 * \pi * R_2 * 10 \text{ kHz}} \quad (3)$$

Table 1. Adjustable LM3670 Configurations for Various V_{OUT}

V_{OUT} (V)	R_1 (k Ω)	R_2 (k Ω)	C_1 (pF)	C_2 (pF)	L (μ H)	C_{IN} (μ F)	C_{OUT} (μ F)
0.7	80.6	200	200	150	4.7	4.7	10
0.8	120	200	130	none	4.7	4.7	10
0.9	160	200	100	none	4.7	4.7	10
1.0	200	200	82	none	4.7	4.7	10
1.1	240	200	68	none	4.7	4.7	10
1.2	280	200	56	none	4.7	4.7	10
1.24	300	200	56	none	4.7	4.7	10
1.24	221	150	75	120	4.7	4.7	10
1.5	402	200	39	none	10	4.7	10
1.6	442	200	39	none	10	4.7	10
1.7	487	200	33	none	10	4.7	10
1.875	549	200	30	none	10	4.7	14.7 (10 4.7)
2.5	806	200	22	82	10	4.7	22

6 Powering the LM3670 for Bench Measurements

When powering the LM3670 with a bench power supply, it is recommended to place a 100 μ F tantalum capacitor across the V_{IN} and GND supply terminals of the bench power supply. This capacitor will reduce the input spike caused by the power supply and long power cables. The combination of the power supply and inductance within the power cables produce a large voltage spike that may damage the device. In addition, consideration must also be looked at the enable pin of the device. The enable should never be taken high, until minimum ensured operating voltage of 2.7V is reached. The enable pin should also never exceed the input voltage.

7 Connection Diagram and Package Mark Information

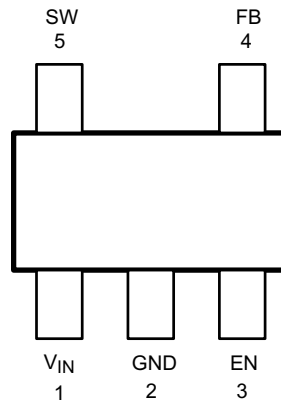

Figure 3. SOT23–5 Package-Top View

Table 2. Pin Descriptions

Pin #	Name	Description
1	V _{IN}	Power supply input. Connect to the input filter capacitor
2	GND	Ground pin
3	EN	Enable input
4	FB	Feedback analog input. Connect to the output filter capacitor
5	SW	Switching node connection to the internal PFET switch and NFET synchronous rectifier. Connect to an inductor with a saturation current rating that exceeds the 750 mA max. Switch Peak Current Limit Specification.

8 Evaluation Board Layout

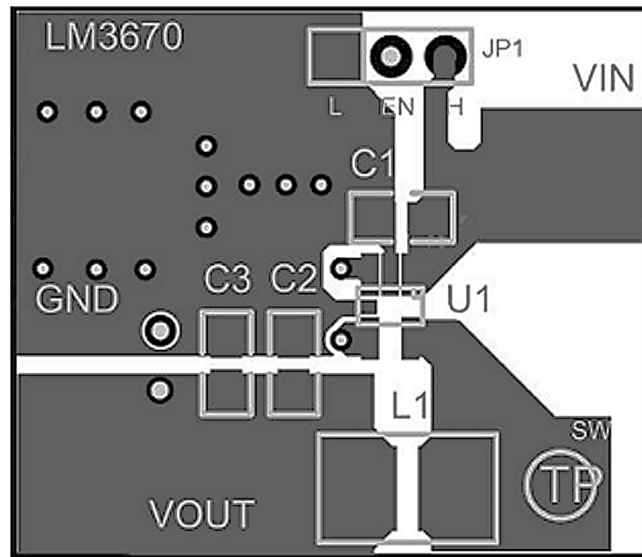

Figure 4. Top Layer

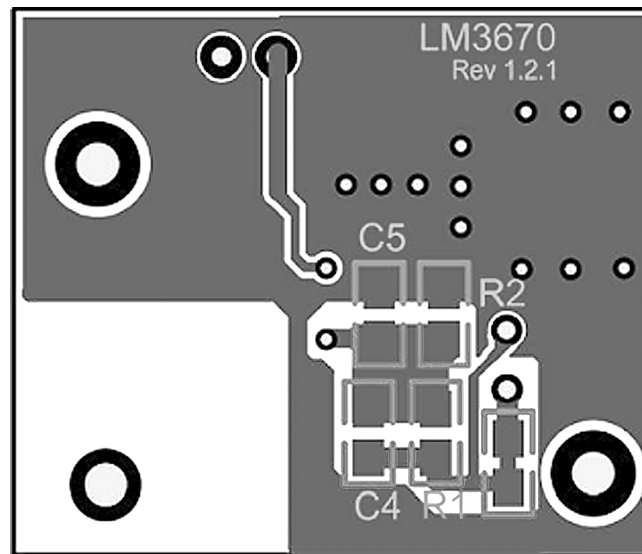

Figure 5. Bottom Layer

Table 3. BOM For Common Configurations

	Manufacture	Manufacture #	Description
LM3670 - 1.8V & 3.3V FIXED			
C1 (input C)	Taiyo Yuden	LMK316BJ475ML	4.7 μ F,10V,20%,1206
C3 (output C)	TDK	3216X5R0J106M	10 μ F,6.3V,20%,1206
C2 (aux output C)			
L1 (inductor)	Coilcraft	DO1608C-103	10 μ H inductor, 1.1A sat
R1 (V_{OUT} to V_{FB})	Vishay	CRCW08050R00F	0 Ω , 0805
C4 (V_{OUT} to V_{FB})			
R2 (V_{FB} to GND)			
C5 (V_{FB} to GND)			
LM3670 - 1.2V ADJUSTABLE			
C1 (input C)	Taiyo Yuden	LMK316BJ475ML	4.7 μ F,10V,20%,1206
C3 (output C)	TDK	3216X5R0J106M	10 μ F,6.3V,20%,1206
C2 (aux output C)			
L1 (inductor)	Coilcraft	DO1608C-472	4.7 μ H inductor, 1.5A sat
R1 (V_{OUT} to V_{FB})	Vishay	CRCW08052803F	280 k Ω , 0805, 1%
C4 (V_{OUT} to V_{FB})	Vishay	VJ0805Y560KXXA	56 pF, 0805, 10%
R2 (V_{FB} to GND)	Vishay	CRCW08052003F	200 k Ω , 0805, 1%
C5 (V_{FB} to GND)			
LM3670 - 1.5V ADJUSTABLE			
C1 (input C)	Taiyo Yuden	LMK316BJ475ML	4.7 μ F,10V,20%,1206
C3 (output C)	TDK	3216X5R0J106M	10 μ F,6.3V,20%,1206
C2 (aux output C)			
L1 (inductor)	Coilcraft	DO1608C-103	10 μ H inductor, 1.1A sat
R1 (V_{OUT} to V_{FB})	Vishay	CRCW08054023F	402 k Ω , 0805, 1%
C4 (V_{OUT} to V_{FB})	Vishay	VJ0805A390KXAA	39 pF, 0805, 10%
R2 (V_{FB} to GND)	Vishay	CRCW08052003F	200 k Ω , 0805, 1%
C5 (V_{FB} to GND)			
LM3670 - 2.5V ADJUSTABLE			
C1 (input C)	Taiyo Yuden	LMK316BJ475ML	4.7 μ F,10V,20%,0805
C3 (output C)	Taiyo Yuden	JMK316BJ226ML	22 μ F,6.3V,20%, 1206
C2 (aux output C)			
L1 (inductor)	Coilcraft	DO1608C-103	10 μ H inductor, 1.1A sat
R1 (V_{OUT} to V_{FB})	Vishay	CRCW08058063F	806 k Ω , 0805, 1%
C4 (V_{OUT} to V_{FB})	Vishay	VJ0805A220KXAA	22 pF, 0805, 10%
R2 (V_{FB} to GND)	Vishay	CRCW08052003F	200 k Ω , 0805, 1%
C5 (V_{FB} to GND)	Vishay	VJ0805A820KXAA	82 pF, 0805, 10%
COMMON TO ALL			
V_{IN} banana jack - red	Johnson Components	108-0902-001	connector, insulated banana jack (red)
V_{OUT} banana jack - yellow	Johnson Components	108-0907-001	connector, insulated banana jack (yellow)
GND banana jack - black	Johnson Components	108-0903-001	connector, insulated banana jack (black)

IMPORTANT NOTICE

Texas Instruments Incorporated and its subsidiaries (TI) reserve the right to make corrections, enhancements, improvements and other changes to its semiconductor products and services per JESD46, latest issue, and to discontinue any product or service per JESD48, latest issue. Buyers should obtain the latest relevant information before placing orders and should verify that such information is current and complete. All semiconductor products (also referred to herein as "components") are sold subject to TI's terms and conditions of sale supplied at the time of order acknowledgment.

TI warrants performance of its components to the specifications applicable at the time of sale, in accordance with the warranty in TI's terms and conditions of sale of semiconductor products. Testing and other quality control techniques are used to the extent TI deems necessary to support this warranty. Except where mandated by applicable law, testing of all parameters of each component is not necessarily performed.

TI assumes no liability for applications assistance or the design of Buyers' products. Buyers are responsible for their products and applications using TI components. To minimize the risks associated with Buyers' products and applications, Buyers should provide adequate design and operating safeguards.

TI does not warrant or represent that any license, either express or implied, is granted under any patent right, copyright, mask work right, or other intellectual property right relating to any combination, machine, or process in which TI components or services are used. Information published by TI regarding third-party products or services does not constitute a license to use such products or services or a warranty or endorsement thereof. Use of such information may require a license from a third party under the patents or other intellectual property of the third party, or a license from TI under the patents or other intellectual property of TI.

Reproduction of significant portions of TI information in TI data books or data sheets is permissible only if reproduction is without alteration and is accompanied by all associated warranties, conditions, limitations, and notices. TI is not responsible or liable for such altered documentation. Information of third parties may be subject to additional restrictions.

Resale of TI components or services with statements different from or beyond the parameters stated by TI for that component or service voids all express and any implied warranties for the associated TI component or service and is an unfair and deceptive business practice. TI is not responsible or liable for any such statements.

Buyer acknowledges and agrees that it is solely responsible for compliance with all legal, regulatory and safety-related requirements concerning its products, and any use of TI components in its applications, notwithstanding any applications-related information or support that may be provided by TI. Buyer represents and agrees that it has all the necessary expertise to create and implement safeguards which anticipate dangerous consequences of failures, monitor failures and their consequences, lessen the likelihood of failures that might cause harm and take appropriate remedial actions. Buyer will fully indemnify TI and its representatives against any damages arising out of the use of any TI components in safety-critical applications.

In some cases, TI components may be promoted specifically to facilitate safety-related applications. With such components, TI's goal is to help enable customers to design and create their own end-product solutions that meet applicable functional safety standards and requirements. Nonetheless, such components are subject to these terms.

No TI components are authorized for use in FDA Class III (or similar life-critical medical equipment) unless authorized officers of the parties have executed a special agreement specifically governing such use.

Only those TI components which TI has specifically designated as military grade or "enhanced plastic" are designed and intended for use in military/aerospace applications or environments. Buyer acknowledges and agrees that any military or aerospace use of TI components which have **not** been so designated is solely at the Buyer's risk, and that Buyer is solely responsible for compliance with all legal and regulatory requirements in connection with such use.

TI has specifically designated certain components as meeting ISO/TS16949 requirements, mainly for automotive use. In any case of use of non-designated products, TI will not be responsible for any failure to meet ISO/TS16949.

Products

Audio	www.ti.com/audio
Amplifiers	amplifier.ti.com
Data Converters	dataconverter.ti.com
DLP® Products	www.dlp.com
DSP	dsp.ti.com
Clocks and Timers	www.ti.com/clocks
Interface	interface.ti.com
Logic	logic.ti.com
Power Mgmt	power.ti.com
Microcontrollers	microcontroller.ti.com
RFID	www.ti-rfid.com
OMAP Applications Processors	www.ti.com/omap
Wireless Connectivity	www.ti.com/wirelessconnectivity

Applications

Automotive and Transportation	www.ti.com/automotive
Communications and Telecom	www.ti.com/communications
Computers and Peripherals	www.ti.com/computers
Consumer Electronics	www.ti.com/consumer-apps
Energy and Lighting	www.ti.com/energy
Industrial	www.ti.com/industrial
Medical	www.ti.com/medical
Security	www.ti.com/security
Space, Avionics and Defense	www.ti.com/space-avionics-defense
Video and Imaging	www.ti.com/video

TI E2E Community

e2e.ti.com