

Full Bridge Power Amplifier

FEATURES

- Dual Power Operational Amplifiers
- $\pm 2A$ Output Current Guaranteed
- Precision Current Sense Amplifier
- Two Supply Monitoring Inputs
- Parking Function and Under-Voltage Lockout
- Safe Operating Area Protection
- 3V to 35V Operation

DESCRIPTION

The UC3176/7 family of full bridge power amplifiers is rated for a continuous output current of 2A. Intended for use in demanding servo applications such as disk head positioning, the onboard current sense amplifier can be used to obtain precision control of load current, or where voltage mode drive is required, a standard voltage feedback scheme can be used. Output stage protection includes foldback current limiting and thermal shutdown, resulting in a very rugged device.

Auxiliary functions on this device include a dual input under-voltage comparator that can be programmed to respond to low voltage conditions on two independent supplies. In response to an under-voltage condition the power Op-Amps are inhibited and a high current, 100mA, open collector drive output is activated. A separate Park/Inhibit command input.

The devices are operational over a 3V to 35V supply range. Internal under-voltage lockout provides predictable power-up and power-down characteristics.

BLOCK DIAGRAM

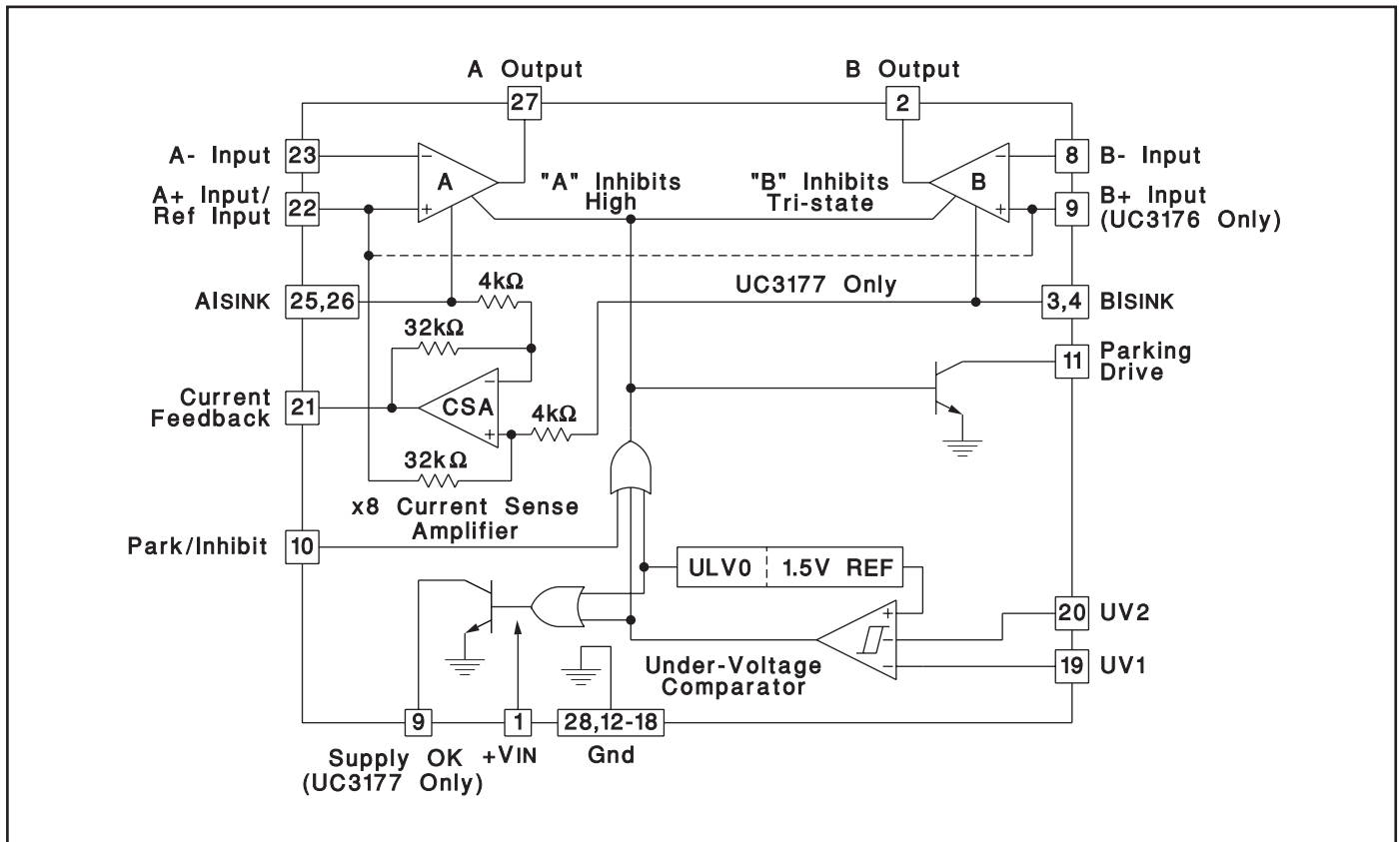

ABSOLUTE MAXIMUM RATINGS (Note 1)

Input Supply voltage, (+V _{IN})	40V
Park/Inhibit, UV1 and UV2 inputs (zener clamped)	
Maximum forced voltage	-0.3V to 10V
Maximum forced current	±10mA
Other Input Voltages	-0.3V to +V _{IN}
A _{SINK} and B _{SINK} Voltages	-0.3V to 6V
Open Collector Output Voltages	40V
A and B Output Currents (Continuous)	
Source	Internally Limited
Sink	2.5A
Total Supply Current (Continuous)	4A
Parking Drive Output Current (Continuous)	200mA
Supply OK Output Current, UC3177 (Continuous)	30mA
Operating Junction Temperature	-55°C to +150°C
Power Dissipation at TC = +75°C	
QP package	4W
Storage Temperature	-65°C to +150°C

THERMAL DATA

QP package:

Thermal Resistance Junction to Leads, θ_{JL}	15°C/W
Thermal Resistance Junction to Ambient, θ_{JA}	50°C/W
Thermal Resistance Junction to C _{OSC} , θ_{JC}	30°C/W

CONNECTION DIAGRAM

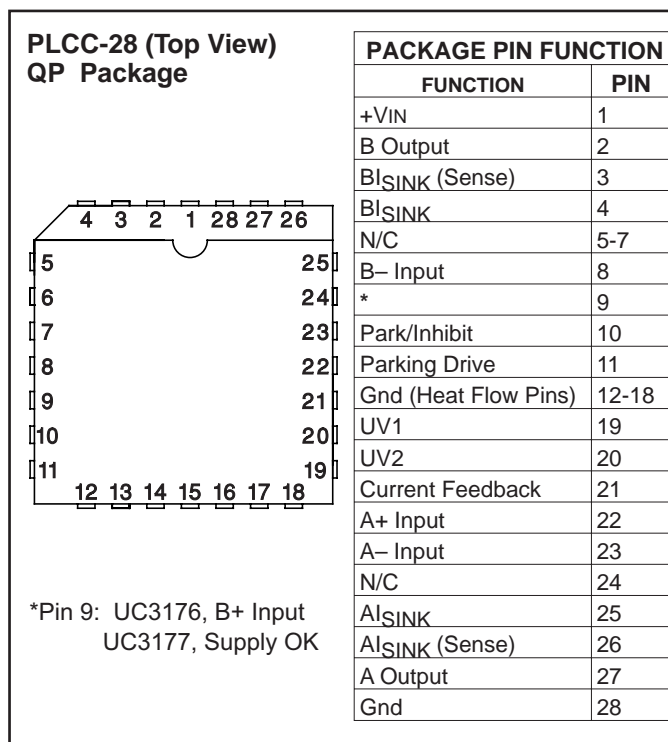

ELECTRICAL CHARACTERISTICS: Unless otherwise stated, specifications hold for T_A = 0 to 70°C, +V_{IN} = 12V, T_A = T_J.

PARAMETER	TEST CONDITIONS	MIN.	TYP.	MAX.	UNITS
Input Supply					
Supply Current	+V _{IN} = 12V		18	25	mA
	+V _{IN} = 35V		21	30	mA
UVOL Threshold	+V _{IN} low to high		2.8	3.0	V
	Threshold Hysteresis		220	300	mV
Power, Amplifier, A and B					
Input Offset Voltage	V _{CM} = 6V, V _{OUT} = 6V			8	mV
Input Bias Current	V _{CM} = 6V, Except A+ Input	-500	-100		nA
Input Bias Current at A+/Reference Input	(A+/REF - B _{SINK}) / 36kΩ; T _J = 25°C	23	28	35	μA/V
Input Offset Current B Amp (UC3176 Only)	V _{CM} = 6V			200	nA
CMRR	V _{CM} = 1 to 33V, +V _{IN} = 35V, V _{OUT} = 6V	70	100		dB
PSRR	+V _{IN} = 5 to 35V, V _{CM} = 2.5V	70	100		dB
Large Signal Voltage Gain	V _{OUT} = 3V, w/I _{OUT} = 1A to V _{OUT} = 9V, w/I _{OUT} = -1A	1.5	4		V/mV
Thermal Feedback	+V _{IN} = 20V, Pd = 20W at opposite output		25	200	μV/W
Saturation Voltage	I _{OUT} = -2A, High Side, T _J = 25°		1.9		V
	C _I _{OUT} = 2A, Low Side, T _J = 25°C		1.6		V
	Total V _{SAT} at 2A, T _J = 25°C		3.5	3.7	V
Unity Gain Bandwidth			1		MHz
Slew Rate			1		V/μs
Differential I _{OUT} Sense Error Current in Bridge Configuration	I _{OUT} (A) = -I _{OUT} (B), /I _{OUT} / - /A _{SINK} - B _{SINK} /				
	I _{OUT} ≤ 200mA		3.0	6.0	mA
	I _{OUT} ≤ 2A		5.0	10	mA
High Side Current Limiting	=V _{IN} - V _{OUT} < 12V		-2.7	-2.0	A

ELECTRICAL CHARACTERISTICS: Unless otherwise stated, specifications hold for $T_A = 0$ to 70°C , $+V_{IN} = 12\text{V}$, $T_A = T_J$.

PARAMETER	TEST CONDITIONS	MIN.	TYP.	MAX.	UNITS
Current Sense Amplifier					
Input Offset Voltage	$V_{CM} = 0\text{V}$, A+ / REF at 6V			3	mV
	REF = 2V to 20V, $+V_{IN} = 35$, change with REF Input voltage			600	$\mu\text{V/V}$
Thermal Gradient Sensitivity	$+V_{IN} = 20\text{V}$, REF = 10V Pd = 20W @ A or B Output		5.0	75.0	$\mu\text{V/W}$
PSRR	REF = 2.5V, $+V_{IN} = 5$ to 35V	70	100		dB
Gain	$ A_{SINK-B SINK} \leq 0.5\text{V}$	7.8	8.0	8.1	V/V
Slew Rate			2		V/ μS
3dB Bandwidth			1		MHz
MAX Output Current	$I_{SOURCE} = +V_{IN} - V_{OUT} = 0.5\text{V}$	2.5	3.5		mA
Output Saturation Voltage	$I_{SOURCE} = 1.5\text{mA}$, High Side		0.15	0.30	V
	$I_{SINK} = 5\text{mA}$, Low Side		1.4	1.85	V
Under-Voltage Comparator					
Threshold Voltage	Low to High, other input at 5V	1.44	1.50	1.56	V
	Threshold Hysteresis	50	70	80	mV
Input Current	Input = 2V, other input at 5V	-2.00	-0.05		μA
Supply OK V_{SAT} (UC3177 Only)	$I_{OUT} = 5\text{mA}$			0.45	V
Supply OK Leakage (UC3177 Only)	$V_{OUT} = 35\text{V}$			5	μA
Park/Inhibit					
Park/Inhibit Th'l'd		1.1	1.3	1.7	V
Park/Inhibit Input Current	At threshold		60	100	μA
Parking Drive Saturation Voltage	$I_{OUT} = 100\text{mA}$		0.3	0.7	V
Parking Drive Leakage	$V_{OUT} = 35\text{V}$			15	μA
Thermal Shutdown					
Shutdown Temperature			165		$^\circ\text{C}$

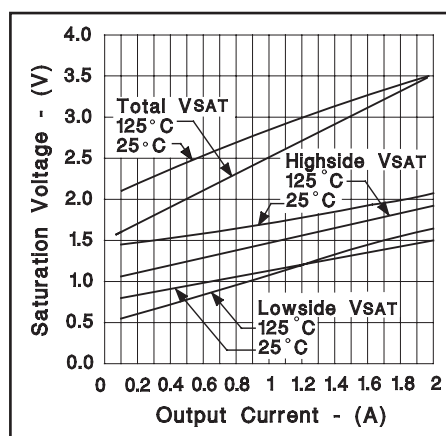

Output saturation voltage vs. current.

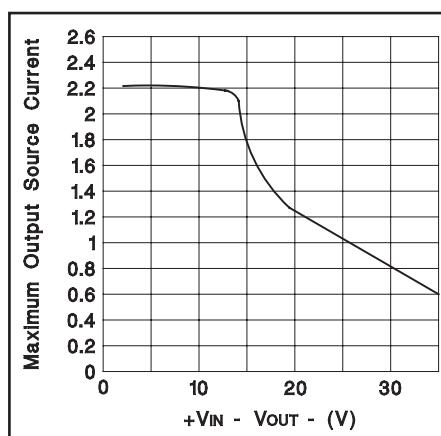

Maximum source current vs. $+V_{IN} - V_{OUT}$.

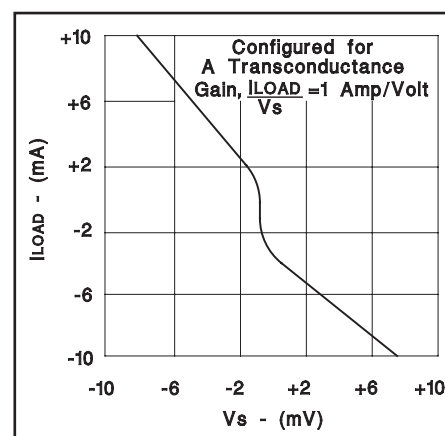

Crossover current error characteristic.

APPLICATION AND OPERATION INFORMATION

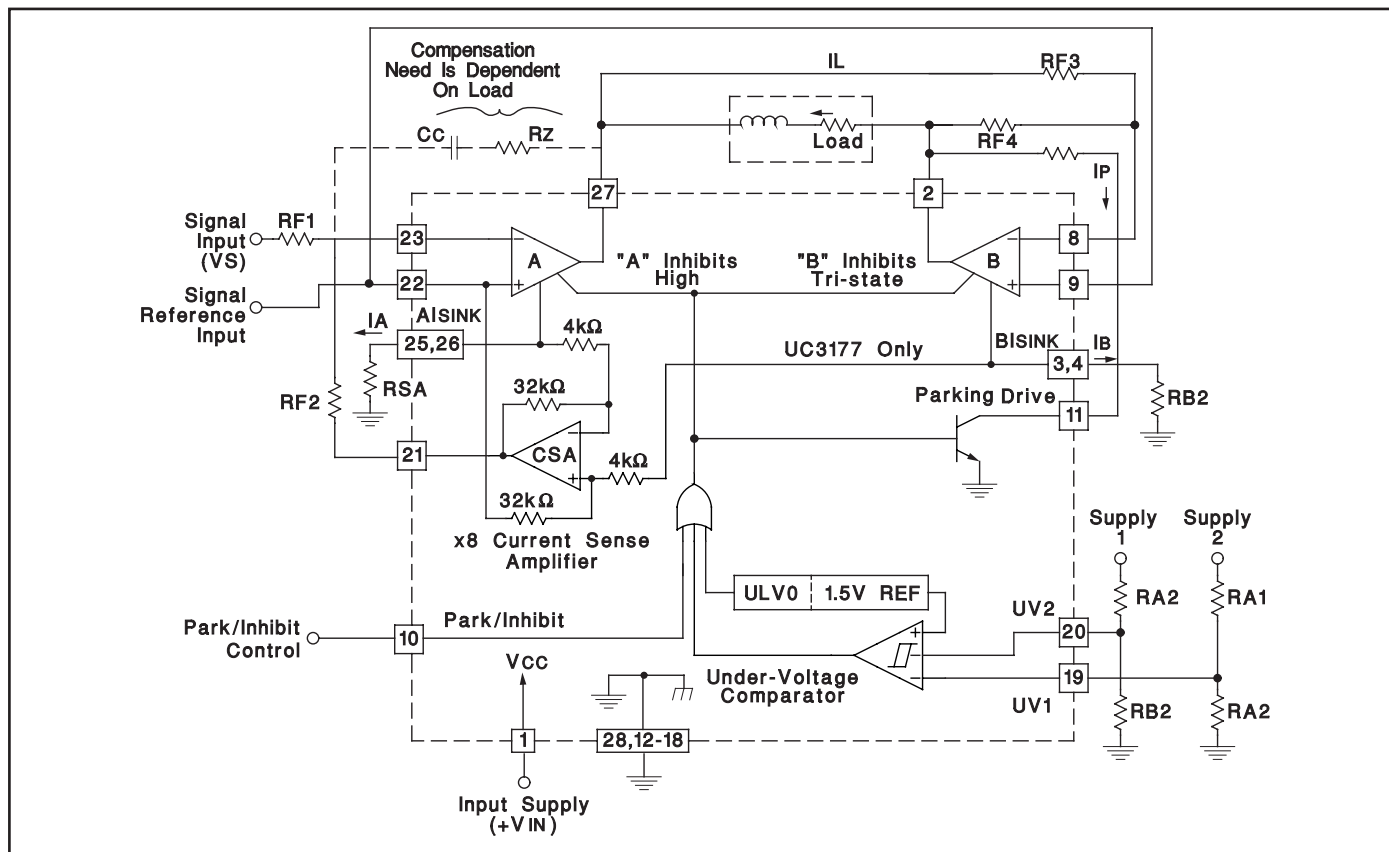

WAVEFORMS FOR ABOVE APPLICATION

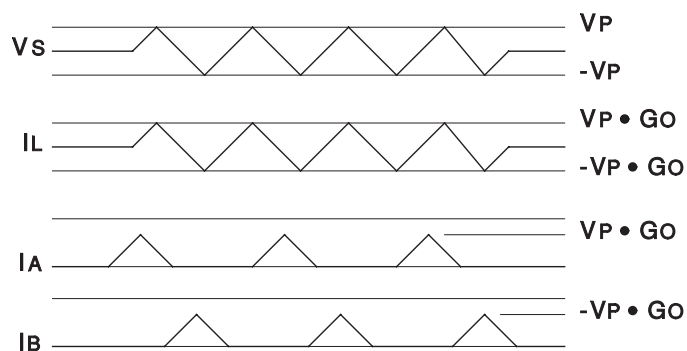

DESIGN EQUATIONS

$$\text{Transconductance } (G_O) = \frac{I_L}{V_S} = \frac{R_{F2}}{R_{F1}} \times \left(\frac{1}{8R_S} \right)$$

with: $R_{SA} = R_{SB}$ and $R_{F3} = R_{F4}$

$$\text{Parking Current } (I_P) = \frac{V_{IN} - 1.5}{R_P + R_L}$$

where: R_L = load resistance

Under-Voltage Thresholds, at Supplies
 High to Low Threshold, $(V_{LH}) = 1.425 (R_A + R_B) / R_B$
 Low to High Threshold, $(V_{HL}) = 1.5 (R_A + R_B) / R_B$

PACKAGING INFORMATION

Orderable Device	Status (1)	Package Type	Package Drawing	Pins	Package Qty	Eco Plan (2)	Lead/Ball Finish	MSL Peak Temp (3)	Op Temp (°C)	Top-Side Markings (4)	Samples
UC3176QP	ACTIVE	PLCC	FN	28	37	Green (RoHS & no Sb/Br)	CU NIPDAU	Level-3-260C-168 HR	0 to 70	UC3176QP	Samples
UC3176QPTR	ACTIVE	PLCC	FN	28	750	TBD	Call TI	Call TI	0 to 70	UC3176QP	Samples

(1) The marketing status values are defined as follows:

ACTIVE: Product device recommended for new designs.

LIFEBUY: TI has announced that the device will be discontinued, and a lifetime-buy period is in effect.

NRND: Not recommended for new designs. Device is in production to support existing customers, but TI does not recommend using this part in a new design.

PREVIEW: Device has been announced but is not in production. Samples may or may not be available.

OBSELETE: TI has discontinued the production of the device.

(2) Eco Plan - The planned eco-friendly classification: Pb-Free (RoHS), Pb-Free (RoHS Exempt), or Green (RoHS & no Sb/Br) - please check <http://www.ti.com/productcontent> for the latest availability information and additional product content details.

TBD: The Pb-Free/Green conversion plan has not been defined.

Pb-Free (RoHS): TI's terms "Lead-Free" or "Pb-Free" mean semiconductor products that are compatible with the current RoHS requirements for all 6 substances, including the requirement that lead not exceed 0.1% by weight in homogeneous materials. Where designed to be soldered at high temperatures, TI Pb-Free products are suitable for use in specified lead-free processes.

Pb-Free (RoHS Exempt): This component has a RoHS exemption for either 1) lead-based flip-chip solder bumps used between the die and package, or 2) lead-based die adhesive used between the die and leadframe. The component is otherwise considered Pb-Free (RoHS compatible) as defined above.

Green (RoHS & no Sb/Br): TI defines "Green" to mean Pb-Free (RoHS compatible), and free of Bromine (Br) and Antimony (Sb) based flame retardants (Br or Sb do not exceed 0.1% by weight in homogeneous material)

(3) MSL, Peak Temp. -- The Moisture Sensitivity Level rating according to the JEDEC industry standard classifications, and peak solder temperature.

(4) Multiple Top-Side Markings will be inside parentheses. Only one Top-Side Marking contained in parentheses and separated by a "~" will appear on a device. If a line is indented then it is a continuation of the previous line and the two combined represent the entire Top-Side Marking for that device.

Important Information and Disclaimer:The information provided on this page represents TI's knowledge and belief as of the date that it is provided. TI bases its knowledge and belief on information provided by third parties, and makes no representation or warranty as to the accuracy of such information. Efforts are underway to better integrate information from third parties. TI has taken and continues to take reasonable steps to provide representative and accurate information but may not have conducted destructive testing or chemical analysis on incoming materials and chemicals. TI and TI suppliers consider certain information to be proprietary, and thus CAS numbers and other limited information may not be available for release.

In no event shall TI's liability arising out of such information exceed the total purchase price of the TI part(s) at issue in this document sold by TI to Customer on an annual basis.

FN (S-PQCC-J**)

PLASTIC J-LEADED CHIP CARRIER

20 PIN SHOWN



- NOTES: A. All linear dimensions are in inches (millimeters).
 B. This drawing is subject to change without notice.
 C. Falls within JEDEC MS-018

IMPORTANT NOTICE

Texas Instruments Incorporated and its subsidiaries (TI) reserve the right to make corrections, enhancements, improvements and other changes to its semiconductor products and services per JESD46, latest issue, and to discontinue any product or service per JESD48, latest issue. Buyers should obtain the latest relevant information before placing orders and should verify that such information is current and complete. All semiconductor products (also referred to herein as "components") are sold subject to TI's terms and conditions of sale supplied at the time of order acknowledgment.

TI warrants performance of its components to the specifications applicable at the time of sale, in accordance with the warranty in TI's terms and conditions of sale of semiconductor products. Testing and other quality control techniques are used to the extent TI deems necessary to support this warranty. Except where mandated by applicable law, testing of all parameters of each component is not necessarily performed.

TI assumes no liability for applications assistance or the design of Buyers' products. Buyers are responsible for their products and applications using TI components. To minimize the risks associated with Buyers' products and applications, Buyers should provide adequate design and operating safeguards.

TI does not warrant or represent that any license, either express or implied, is granted under any patent right, copyright, mask work right, or other intellectual property right relating to any combination, machine, or process in which TI components or services are used. Information published by TI regarding third-party products or services does not constitute a license to use such products or services or a warranty or endorsement thereof. Use of such information may require a license from a third party under the patents or other intellectual property of the third party, or a license from TI under the patents or other intellectual property of TI.

Reproduction of significant portions of TI information in TI data books or data sheets is permissible only if reproduction is without alteration and is accompanied by all associated warranties, conditions, limitations, and notices. TI is not responsible or liable for such altered documentation. Information of third parties may be subject to additional restrictions.

Resale of TI components or services with statements different from or beyond the parameters stated by TI for that component or service voids all express and any implied warranties for the associated TI component or service and is an unfair and deceptive business practice. TI is not responsible or liable for any such statements.

Buyer acknowledges and agrees that it is solely responsible for compliance with all legal, regulatory and safety-related requirements concerning its products, and any use of TI components in its applications, notwithstanding any applications-related information or support that may be provided by TI. Buyer represents and agrees that it has all the necessary expertise to create and implement safeguards which anticipate dangerous consequences of failures, monitor failures and their consequences, lessen the likelihood of failures that might cause harm and take appropriate remedial actions. Buyer will fully indemnify TI and its representatives against any damages arising out of the use of any TI components in safety-critical applications.

In some cases, TI components may be promoted specifically to facilitate safety-related applications. With such components, TI's goal is to help enable customers to design and create their own end-product solutions that meet applicable functional safety standards and requirements. Nonetheless, such components are subject to these terms.

No TI components are authorized for use in FDA Class III (or similar life-critical medical equipment) unless authorized officers of the parties have executed a special agreement specifically governing such use.

Only those TI components which TI has specifically designated as military grade or "enhanced plastic" are designed and intended for use in military/aerospace applications or environments. Buyer acknowledges and agrees that any military or aerospace use of TI components which have **not** been so designated is solely at the Buyer's risk, and that Buyer is solely responsible for compliance with all legal and regulatory requirements in connection with such use.

TI has specifically designated certain components as meeting ISO/TS16949 requirements, mainly for automotive use. In any case of use of non-designated products, TI will not be responsible for any failure to meet ISO/TS16949.

Products

Audio	www.ti.com/audio
Amplifiers	amplifier.ti.com
Data Converters	dataconverter.ti.com
DLP® Products	www.dlp.com
DSP	dsp.ti.com
Clocks and Timers	www.ti.com/clocks
Interface	interface.ti.com
Logic	logic.ti.com
Power Mgmt	power.ti.com
Microcontrollers	microcontroller.ti.com
RFID	www.ti-rfid.com
OMAP Applications Processors	www.ti.com/omap
Wireless Connectivity	www.ti.com/wirelessconnectivity

Applications

Automotive and Transportation	www.ti.com/automotive
Communications and Telecom	www.ti.com/communications
Computers and Peripherals	www.ti.com/computers
Consumer Electronics	www.ti.com/consumer-apps
Energy and Lighting	www.ti.com/energy
Industrial	www.ti.com/industrial
Medical	www.ti.com/medical
Security	www.ti.com/security
Space, Avionics and Defense	www.ti.com/space-avionics-defense
Video and Imaging	www.ti.com/video

TI E2E Community

e2e.ti.com