

Kinetis KL02 32 KB Flash

48 MHz Cortex-M0+ Based Microcontroller

Designed with efficiency in mind. Features a size efficient, ultra-small package, energy efficient ARM Cortex-M0+ 32-bit performance. Shares the comprehensive enablement and scalability of the Kinetis family.

This product offers:

- Run power consumption down to 36 $\mu\text{A}/\text{MHz}$ in very low power run mode
- Static power consumption down to 2 μA with full state retention and 4 μs wakeup
- Ultra-efficient Cortex-M0+ processor running up to 48 MHz with industry leading throughput up to 15.9 CoreMark/mA¹
- Memory option is up to 32 KB flash and 4 KB RAM
- Energy-saving architecture is optimized for low power with 90nm TFS technology, clock and power gating techniques, and zero wait state flash memory controller

MKL02ZxxVFG4
MKL02ZxxVFK4
MKL02ZxxVFM4

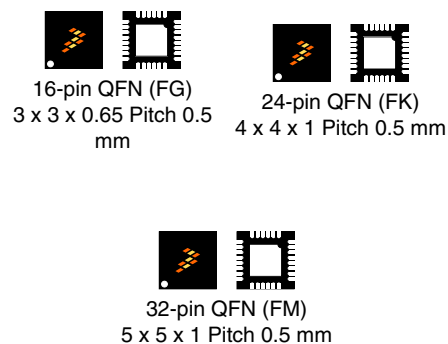

Performance

- 48 MHz ARM[®] Cortex[®]-M0+ core

Memories and memory interfaces

- Up to 32 KB program flash memory
- Up to 4 KB SRAM

System peripherals

- Nine low-power modes to provide power optimization based on application requirements
- COP Software watchdog
- SWD debug interface and Micro Trace Buffer
- Bit Manipulation Engine

Clocks

- 32 kHz to 40 kHz crystal oscillator
- Multi-purpose clock source
- 1 kHz LPO clock

Operating Characteristics

- Voltage range: 1.71 to 3.6 V
- Flash write voltage range: 1.71 to 3.6 V
- Temperature range (ambient): -40 to 105°C

1. CoreMark 1.0: 106.38 /IAR for ARM V6.50.2 --debug --endian=little --cpu=Cortex-M0 -e --fpu=None -Ohs --use_c++_inline/ Code in internal Flash, Data in internal RAM, Stack/ Processor operating frequency = 48 MHz, operating voltage = 3.3 V

Human-machine interface

- Up to 28 general-purpose input/output (GPIO)

Communication interfaces

- One 8-bit SPI module
- One low power UART module
- Two I2C module

Analog Modules

- 12-bit SAR ADC
- Analog comparator (CMP) containing a 6-bit DAC and programmable reference input

Timers

- Two 2-channel Timer/PWM modules
- 16-bit low-power timer (LPTMR)

Security and integrity modules

- 80-bit unique identification number per chip

Ordering Information

Part Number	Memory		Maximum number of I/O's
	Flash (KB)	SRAM (KB)	
MKL02Z8VFG4	8	1	14
MKL02Z16VFG4	16	2	14
MKL02Z32VFG4	32	4	14
MKL02Z16VFK4	16	2	22
MKL02Z32VFK4	32	4	22
MKL02Z16VFM4	16	2	28
MKL02Z32VFM4	32	4	28

Related Resources

Type	Description
Selector Guide	The Freescale Solution Advisor is a web-based tool that features interactive application wizards and a dynamic product selector.
Product Brief	The Product Brief contains concise overview/summary information to enable quick evaluation of a device for design suitability.
Reference Manual	The Reference Manual contains a comprehensive description of the structure and function (operation) of a device.
Data Sheet	The Data Sheet includes electrical characteristics and signal connections.
Chip Errata	The chip mask set Errata provides additional or corrective information for a particular device mask set.
Package drawing	Package dimensions are provided in package drawings.

Table of Contents

1	Ratings.....	4	3.6.1	ADC electrical specifications.....	23
1.1	Thermal handling ratings.....	4	3.6.2	CMP and 6-bit DAC electrical specifications....	26
1.2	Moisture handling ratings.....	4	3.7	Timers.....	28
1.3	ESD handling ratings.....	4	3.8	Communication interfaces.....	28
1.4	Voltage and current operating ratings.....	4	3.8.1	SPI switching specifications.....	28
2	General.....	5	3.8.2	Inter-Integrated Circuit Interface (I2C) timing..	32
2.1	AC electrical characteristics.....	5	3.8.3	UART.....	34
2.2	Nonswitching electrical specifications.....	5	4	Dimensions.....	34
2.2.1	Voltage and current operating requirements....	5	4.1	Obtaining package dimensions.....	34
2.2.2	LVD and POR operating requirements.....	6	5	Pinout.....	34
2.2.3	Voltage and current operating behaviors.....	7	5.1	KL02 signal multiplexing and pin assignments.....	34
2.2.4	Power mode transition operating behaviors....	8	5.2	KL02 pinouts.....	36
2.2.5	Power consumption operating behaviors.....	9	6	Ordering parts.....	38
2.2.6	EMC radiated emissions operating behaviors..	14	6.1	Determining valid orderable parts.....	38
2.2.7	Designing with radiated emissions in mind.....	15	7	Part identification.....	38
2.2.8	Capacitance attributes.....	15	7.1	Description.....	38
2.3	Switching specifications.....	15	7.2	Format.....	39
2.3.1	Device clock specifications.....	15	7.3	Fields.....	39
2.3.2	General switching specifications.....	16	7.4	Example.....	39
2.4	Thermal specifications.....	16	8	Small package marking.....	40
2.4.1	Thermal operating requirements.....	16	9	Terminology and guidelines.....	40
2.4.2	Thermal attributes.....	16	9.1	Definition: Operating requirement.....	40
3	Peripheral operating requirements and behaviors.....	17	9.2	Definition: Operating behavior.....	41
3.1	Core modules.....	17	9.3	Definition: Attribute.....	41
3.1.1	SWD electricals	17	9.4	Definition: Rating.....	41
3.2	System modules.....	19	9.5	Result of exceeding a rating.....	42
3.3	Clock modules.....	19	9.6	Relationship between ratings and operating requirements.....	42
3.3.1	MCG specifications.....	19	9.7	Guidelines for ratings and operating requirements....	43
3.3.2	Oscillator electrical specifications.....	20	9.8	Definition: Typical value.....	43
3.4	Memories and memory interfaces.....	21	9.9	Typical value conditions.....	44
3.4.1	Flash electrical specifications.....	21	10	Revision history.....	45
3.5	Security and integrity modules.....	23			
3.6	Analog.....	23			

1 Ratings

1.1 Thermal handling ratings

Table 1. Thermal handling ratings

Symbol	Description	Min.	Max.	Unit	Notes
T _{STG}	Storage temperature	-55	150	°C	1
T _{SDR}	Solder temperature, lead-free	—	260	°C	2

1. Determined according to JEDEC Standard JESD22-A103, *High Temperature Storage Life*.
2. Determined according to IPC/JEDEC Standard J-STD-020, *Moisture/Reflow Sensitivity Classification for Nonhermetic Solid State Surface Mount Devices*.

1.2 Moisture handling ratings

Table 2. Moisture handling ratings

Symbol	Description	Min.	Max.	Unit	Notes
MSL	Moisture sensitivity level	—	3	—	1

1. Determined according to IPC/JEDEC Standard J-STD-020, *Moisture/Reflow Sensitivity Classification for Nonhermetic Solid State Surface Mount Devices*.

1.3 ESD handling ratings

Table 3. ESD handling ratings

Symbol	Description	Min.	Max.	Unit	Notes
V _{HBM}	Electrostatic discharge voltage, human body model	-2000	+2000	V	1
V _{CDM}	Electrostatic discharge voltage, charged-device model	-500	+500	V	2
I _{LAT}	Latch-up current at ambient temperature of 105 °C	-100	+100	mA	3

1. Determined according to JEDEC Standard JESD22-A114, *Electrostatic Discharge (ESD) Sensitivity Testing Human Body Model (HBM)*.
2. Determined according to JEDEC Standard JESD22-C101, *Field-Induced Charged-Device Model Test Method for Electrostatic-Discharge-Withstand Thresholds of Microelectronic Components*.
3. Determined according to JEDEC Standard JESD78, *IC Latch-Up Test*.

1.4 Voltage and current operating ratings

Table 4. Voltage and current operating ratings

Symbol	Description	Min.	Max.	Unit
V_{DD}	Digital supply voltage	-0.3	3.8	V
I_{DD}	Digital supply current	—	120	mA
V_{IO}	IO pin input voltage	-0.3	$V_{DD} + 0.3$	V
I_D	Instantaneous maximum current single pin limit (applies to all port pins)	-25	25	mA
V_{DDA}	Analog supply voltage	$V_{DD} - 0.3$	$V_{DD} + 0.3$	V

2 General

2.1 AC electrical characteristics

Unless otherwise specified, propagation delays are measured from the 50% to the 50% point, and rise and fall times are measured at the 20% and 80% points, as shown in the following figure.

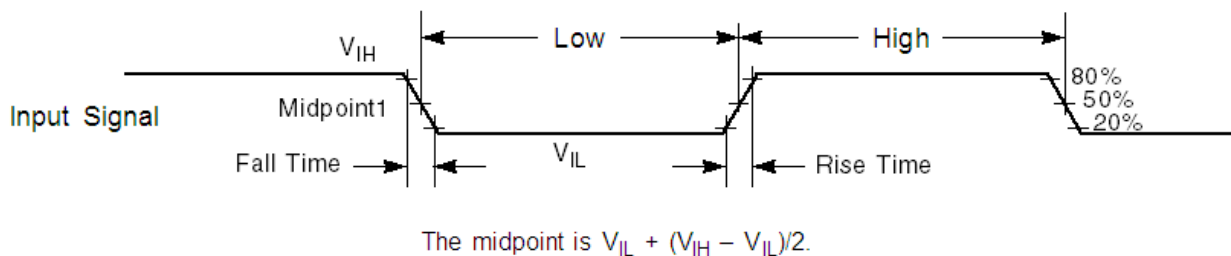

Figure 1. Input signal measurement reference

All digital I/O switching characteristics, unless otherwise specified, assume the output pins have the following characteristics.

- $C_L=30$ pF loads
- Slew rate disabled
- Normal drive strength

2.2 Nonswitching electrical specifications

2.2.1 Voltage and current operating requirements

Table 5. Voltage and current operating requirements

Symbol	Description	Min.	Max.	Unit	Notes
V _{DD}	Supply voltage	1.71	3.6	V	
V _{DDA}	Analog supply voltage	1.71	3.6	V	—
V _{DD} – V _{DDA}	V _{DD} -to-V _{DDA} differential voltage	–0.1	0.1	V	—
V _{SS} – V _{SSA}	V _{SS} -to-V _{SSA} differential voltage	–0.1	0.1	V	—
V _{IH}	Input high voltage <ul style="list-style-type: none"> • 2.7 V ≤ V_{DD} ≤ 3.6 V • 1.7 V ≤ V_{DD} ≤ 2.7 V 	0.7 × V _{DD}	—	V	—
		0.75 × V _{DD}	—	V	
V _{IL}	Input low voltage <ul style="list-style-type: none"> • 2.7 V ≤ V_{DD} ≤ 3.6 V • 1.7 V ≤ V_{DD} ≤ 2.7 V 	—	0.35 × V _{DD}	V	—
		—	0.3 × V _{DD}	V	
V _{HYS}	Input hysteresis	0.06 × V _{DD}	—	V	—
I _{ICIO}	IO pin negative DC injection current—single pin <ul style="list-style-type: none"> • V_{IN} < V_{SS}–0.3V 	–5	—	mA	1
I _{ICcont}	Contiguous pin DC injection current —regional limit, includes sum of negative injection currents of 16 contiguous pins <ul style="list-style-type: none"> • Negative current injection 	–25	—	mA	—
V _{ODPU}	Open drain pullup voltage level	V _{DD}	V _{DD}	V	2
V _{RAM}	V _{DD} voltage required to retain RAM	1.2	—	V	—

- All I/O pins are internally clamped to V_{SS} through a ESD protection diode. There is no diode connection to V_{DD}. If V_{IN} greater than V_{IO_MIN} (= V_{SS}–0.3 V) is observed, then there is no need to provide current limiting resistors at the pads. If this limit cannot be observed then a current limiting resistor is required. The negative DC injection current limiting resistor is calculated as $R = (V_{IO_MIN} - V_{IN})/|I_{ICIO}|$.
- Open drain outputs must be pulled to V_{DD}.

2.2.2 LVD and POR operating requirements

Table 6. V_{DD} supply LVD and POR operating requirements

Symbol	Description	Min.	Typ.	Max.	Unit	Notes
V _{POR}	Falling V _{DD} POR detect voltage	0.8	1.1	1.5	V	—
V _{LVDH}	Falling low-voltage detect threshold — high range (LVDV = 01)	2.48	2.56	2.64	V	—
V _{LVW1H} V _{LVW2H}	Low-voltage warning thresholds — high range <ul style="list-style-type: none"> • Level 1 falling (LVWV = 00) • Level 2 falling (LVWV = 01) 	2.62	2.70	2.78	V	1
		2.72	2.80	2.88	V	

Table continues on the next page...

Table 6. V_{DD} supply LVD and POR operating requirements (continued)

Symbol	Description	Min.	Typ.	Max.	Unit	Notes
V _{LW3H}	• Level 3 falling (LVWV = 10)	2.82	2.90	2.98	V	
V _{LW4H}	• Level 4 falling (LVWV = 11)	2.92	3.00	3.08	V	
V _{HYSH}	Low-voltage inhibit reset/recover hysteresis — high range	—	±60	—	mV	—
V _{LVDL}	Falling low-voltage detect threshold — low range (LVDV=00)	1.54	1.60	1.66	V	—
V _{LW1L}	Low-voltage warning thresholds — low range • Level 1 falling (LVWV = 00)	1.74	1.80	1.86	V	1
V _{LW2L}	• Level 2 falling (LVWV = 01)	1.84	1.90	1.96	V	
V _{LW3L}	• Level 3 falling (LVWV = 10)	1.94	2.00	2.06	V	
V _{LW4L}	• Level 4 falling (LVWV = 11)	2.04	2.10	2.16	V	
V _{HYSL}	Low-voltage inhibit reset/recover hysteresis — low range	—	±40	—	mV	—
V _{BG}	Bandgap voltage reference	0.97	1.00	1.03	V	—
t _{LPO}	Internal low power oscillator period — factory trimmed	900	1000	1100	µs	—

1. Rising thresholds are falling threshold + hysteresis voltage

2.2.3 Voltage and current operating behaviors

Table 7. Voltage and current operating behaviors

Symbol	Description	Min.	Max.	Unit	Notes
V _{OH}	Output high voltage — Normal drive pad (except RESET) • 2.7 V ≤ V _{DD} ≤ 3.6 V, I _{OH} = -5 mA • 1.71 V ≤ V _{DD} ≤ 2.7 V, I _{OH} = -2.5 mA	V _{DD} - 0.5 V _{DD} - 0.5	— —	V V	1, 2
V _{OH}	Output high voltage — High drive pad (except RESET_b) • 2.7 V ≤ V _{DD} ≤ 3.6 V, I _{OH} = -20 mA • 1.71 V ≤ V _{DD} ≤ 2.7 V, I _{OH} = -10 mA	V _{DD} - 0.5 V _{DD} - 0.5	— —	V V	1, 2
I _{OHT}	Output high current total for all ports	—	100	mA	
V _{OL}	Output low voltage — Normal drive pad • 2.7 V ≤ V _{DD} ≤ 3.6 V, I _{OL} = 5 mA • 1.71 V ≤ V _{DD} ≤ 2.7 V, I _{OL} = 2.5 mA	— —	0.5 0.5	V V	1
V _{OL}	Output low voltage — High drive pad				1

Table continues on the next page...

Table 7. Voltage and current operating behaviors (continued)

Symbol	Description	Min.	Max.	Unit	Notes
	<ul style="list-style-type: none"> • $2.7\text{ V} \leq V_{DD} \leq 3.6\text{ V}$, $I_{OL} = 20\text{ mA}$ • $1.71\text{ V} \leq V_{DD} \leq 2.7\text{ V}$, $I_{OL} = 10\text{ mA}$ 	—	0.5	V	
		—	0.5	V	
I_{OLT}	Output low current total for all ports	—	100	mA	
I_{IN}	Input leakage current (per pin) for full temperature range	—	1	μA	3
I_{IN}	Input leakage current (per pin) at 25 °C	—	0.025	μA	3
I_{IN}	Input leakage current (total all pins) for full temperature range	—	41	μA	3
I_{OZ}	Hi-Z (off-state) leakage current (per pin)	—	1	μA	
R_{PU}	Internal pullup resistors	20	50	k Ω	4

1. PTA12, PTA13, PTB0 and PTB1 I/O have both high drive and normal drive capability selected by the associated PTx_PCRn[DSE] control bit. All other GPIOs are normal drive only.
2. The reset pin only contains an active pull down device when configured as the RESET signal or as a GPIO. When configured as a GPIO output, it acts as a pseudo open drain output.
3. Measured at $V_{DD} = 3.6\text{ V}$
4. Measured at V_{DD} supply voltage = V_{DD} min and $V_{input} = V_{SS}$

2.2.4 Power mode transition operating behaviors

All specifications except t_{POR} and $VLLSx \rightarrow RUN$ recovery times in the following table assume this clock configuration:

- CPU and system clocks = 48 MHz
- Bus and flash clock = 24 MHz
- FEI clock mode

POR and $VLLSx \rightarrow RUN$ recovery use FEI clock mode at the default CPU and system frequency of 21 MHz, and a bus and flash clock frequency of 10.5 MHz.

Table 8. Power mode transition operating behaviors

Symbol	Description	Min.	Typ.	Max.	Unit	
t_{POR}	After a POR event, amount of time from the point V_{DD} reaches 1.8 V to execution of the first instruction across the operating temperature range of the chip.	—	—	300	μs	1
	<ul style="list-style-type: none"> • $VLLS0 \rightarrow RUN$ 	—	95	115	μs	
	<ul style="list-style-type: none"> • $VLLS1 \rightarrow RUN$ 	—	93	115	μs	

Table continues on the next page...

Table 8. Power mode transition operating behaviors (continued)

Symbol	Description	Min.	Typ.	Max.	Unit	
	• VLLS3 → RUN	—	42	53	μs	
	• VLPS → RUN	—	4	4.4	μs	
	• STOP → RUN	—	4	4.4	μs	

1. Normal boot (FTFA_FOPT[LPBOOT]=11).

2.2.5 Power consumption operating behaviors

Table 9. Power consumption operating behaviors

Symbol	Description	Min.	Typ.	Max.	Unit	Notes
I _{DDA}	Analog supply current	—	—	See note 1	mA	1
I _{DD_RUNCO}	Run mode current in compute operation—48 MHz core / 24 MHz flash / bus clock disabled, code of while(1) loop executing from flash <ul style="list-style-type: none"> at 3.0 V 	—	3.6	4.7	mA	2
I _{DD_RUN}	Run mode current—48 MHz core / 24 MHz bus and flash, all peripheral clocks disabled, code of while(1) loop executing from flash <ul style="list-style-type: none"> at 3.0 V 	—	4.26	5.3	mA	2
I _{DD_RUN}	Run mode current—48 MHz core / 24 MHz bus and flash, all peripheral clocks enabled, code of while(1) loop executing from flash <ul style="list-style-type: none"> at 3.0 V <ul style="list-style-type: none"> at 25 °C at 125 °C 	—	4.75 4.97	6.4 7.0	mA mA	2, 3
I _{DD_WAIT}	Wait mode current—core disabled / 48 MHz system / 24 MHz bus / flash disabled (flash doze enabled), all peripheral clocks disabled <ul style="list-style-type: none"> at 3.0 V 	—	3.18	4.1	mA	2
I _{DD_WAIT}	Wait mode current—core disabled / 24 MHz system / 24 MHz bus / flash disabled (flash doze enabled), all peripheral clocks disabled <ul style="list-style-type: none"> at 3.0 V 	—	2.62	2.9	mA	2
I _{DD_PSTOP2}	Stop mode current with partial stop 2 clocking option—core and system disabled / 10.5 MHz bus	—	2.18	3.27	mA	2

Table continues on the next page...

Table 9. Power consumption operating behaviors (continued)

Symbol	Description	Min.	Typ.	Max.	Unit	Notes
	<ul style="list-style-type: none"> at 3.0 V 					
I _{DD_VLPRCO}	Very-low-power run mode current in compute operation—4 MHz core / 0.8 MHz flash / bus clock disabled, code of while(1) loop executing from flash <ul style="list-style-type: none"> at 3.0 V 	—	144.7	434.7	μA	4
I _{DD_VLPR}	Very-low-power run mode current—4 MHz core / 0.8 MHz bus and flash, all peripheral clocks disabled, code of while(1) loop executing from flash <ul style="list-style-type: none"> at 3.0 V 	—	165.2	314.0	μA	4
I _{DD_VLPR}	Very-low-power run mode current—4 MHz core / 0.8 MHz bus and flash, all peripheral clocks enabled, code of while(1) loop executing from flash <ul style="list-style-type: none"> at 3.0 V 	—	184.8	351.2	μA	3, 4
I _{DD_VLPW}	Very-low-power wait mode current—core disabled / 4 MHz system / 0.8 MHz bus / flash disabled (flash doze enabled), all peripheral clocks disabled <ul style="list-style-type: none"> at 3.0 V 	—	93.4	334.4	μA	4
I _{DD_STOP}	Stop mode current <ul style="list-style-type: none"> at 3.0 V <ul style="list-style-type: none"> at 25 °C at 50 °C at 70 °C at 85 °C at 105 °C 	— — — — —	255 259.8 273.2 292.0 339.2	427.5 551.0 589.0 684.0 798	μA	—
I _{DD_VLPS}	Very-low-power stop mode current <ul style="list-style-type: none"> at 3.0 V <ul style="list-style-type: none"> at 25 °C at 50 °C at 70 °C at 85 °C at 105 °C 	— — — — —	1.86 3.69 7.6 13.9 31.12	10.5 13.0 26.8 46.0 95.0	μA	—
I _{DD_VLLS3}	Very-low-leakage stop mode 3 current <ul style="list-style-type: none"> at 3.0 V <ul style="list-style-type: none"> at 25 °C at 50 °C at 70 °C 	— — — —	1.24 1.44 2.32 3.89 8.62	2.9 3.6 8.0 9.9 19.0	μA	—

Table continues on the next page...

Table 9. Power consumption operating behaviors (continued)

Symbol	Description	Min.	Typ.	Max.	Unit	Notes
	<ul style="list-style-type: none"> at 85 °C at 105 °C 	—				
I _{DD_VLLS1}	Very-low-leakage stop mode 1 current <ul style="list-style-type: none"> at 3.0 V at 25°C at 50°C at 70°C at 85°C at 105°C 	—	0.6 0.797 1.41 2.54 6.2	1.38 2.3 10.5 10.7 12.8	μA	—
I _{DD_VLLS0}	Very-low-leakage stop mode 0 current (SMC_STOPCTRL[PORPO] = 0) <ul style="list-style-type: none"> at 3.0 V at 25 °C at 50 °C at 70 °C at 85 °C at 105 °C 	—	346 486.1 1090 2230 5880	928.5 1227 2250 4020 9540	nA	—
I _{DD_VLLS0}	Very-low-leakage stop mode 0 current (SMC_STOPCTRL[PORPO] = 1) <ul style="list-style-type: none"> at 3.0 V at 25 °C at 50 °C at 70 °C at 85 °C at 105 °C 	—	160.3 304.3 906.3 2030 5670	837.9 1166.6 2470 4883 11590	nA	5

- The analog supply current is the sum of the active or disabled current for each of the analog modules on the device. See each module's specification for its supply current.
- MCG configured for FEI mode.
- Incremental current consumption from peripheral activity is not included.
- MCG configured for BLPI mode.
- No brownout

Table 10. Low power mode peripheral adders — typical value

Symbol	Description	Temperature (°C)						Unit
		-40	25	50	70	85	105	
I _{IREFSTEN4MHZ}	4 MHz internal reference clock (IRC) adder. Measured by entering STOP or VLPS mode with 4 MHz IRC enabled.	56	56	56	56	56	56	μA

Table continues on the next page...

Table 10. Low power mode peripheral adders — typical value (continued)

Symbol	Description	Temperature (°C)						Unit
		-40	25	50	70	85	105	
I _{REFSTEN32KHz}	32 kHz internal reference clock (IRC) adder. Measured by entering STOP mode with the 32 kHz IRC enabled.	52	52	52	52	52	52	μA
I _{REFSTEN32KHz}	External 32 kHz crystal clock adder by means of the OSC0_CR[EREFSTEN and EREFSTEN] bits. Measured by entering all modes with the crystal enabled. <ul style="list-style-type: none"> • VLLS1 • VLLS3 • VLPS • STOP 	440	490	540	560	570	580	nA
		440	490	540	560	570	580	
		510	560	560	560	610	680	
		510	560	560	560	610	680	
I _{CMP}	CMP peripheral adder measured by placing the device in VLLS1 mode with CMP enabled using the 6-bit DAC and a single external input for compare. Includes 6-bit DAC power consumption.	22	22	22	22	22	22	μA
I _{UART}	UART peripheral adder measured by placing the device in STOP or VLPS mode with selected clock source waiting for RX data at 115200 baud rate. Includes selected clock source power consumption. <ul style="list-style-type: none"> • MCGIRCLK (4 MHz internal reference clock) 	66	66	66	66	66	66	μA
I _{TPM}	TPM peripheral adder measured by placing the device in STOP or VLPS mode with selected clock source configured for output compare generating 100 Hz clock signal. No load is placed on the I/O generating the clock signal. Includes selected clock source and I/O switching currents. <ul style="list-style-type: none"> • MCGIRCLK (4 MHz internal reference clock) 	86	86	86	86	86	86	μA
I _{BG}	Bandgap adder when BGEN bit is set and device is placed in VLPx, or VLLSx mode.	45	45	45	45	45	45	μA
I _{ADC}	ADC peripheral adder combining the measured values at V _{DD} and V _{DDA} by placing the device in STOP or VLPS mode. ADC is configured for low power mode using the internal clock and continuous conversions.	366	366	366	366	366	366	μA

2.2.5.1 Diagram: Typical IDD_RUN operating behavior

The following data was measured under these conditions:

- MCG in FBE for run mode, and BLPE for VLPR mode
- No GPIOs toggled
- Code execution from flash with cache enabled
- For the ALLOFF curve, all peripheral clocks are disabled except FTFA

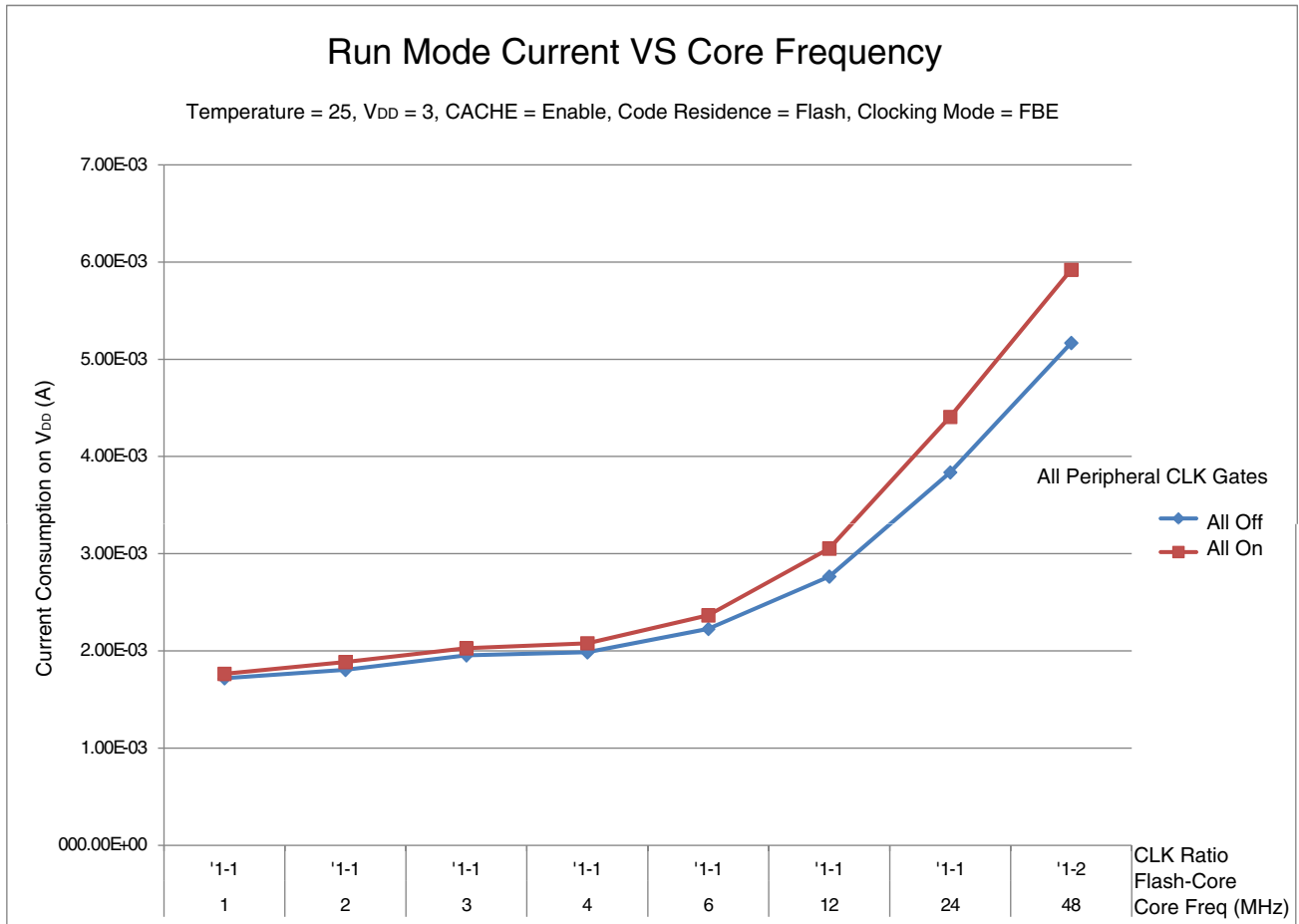

Figure 2. Run mode supply current vs. core frequency

General

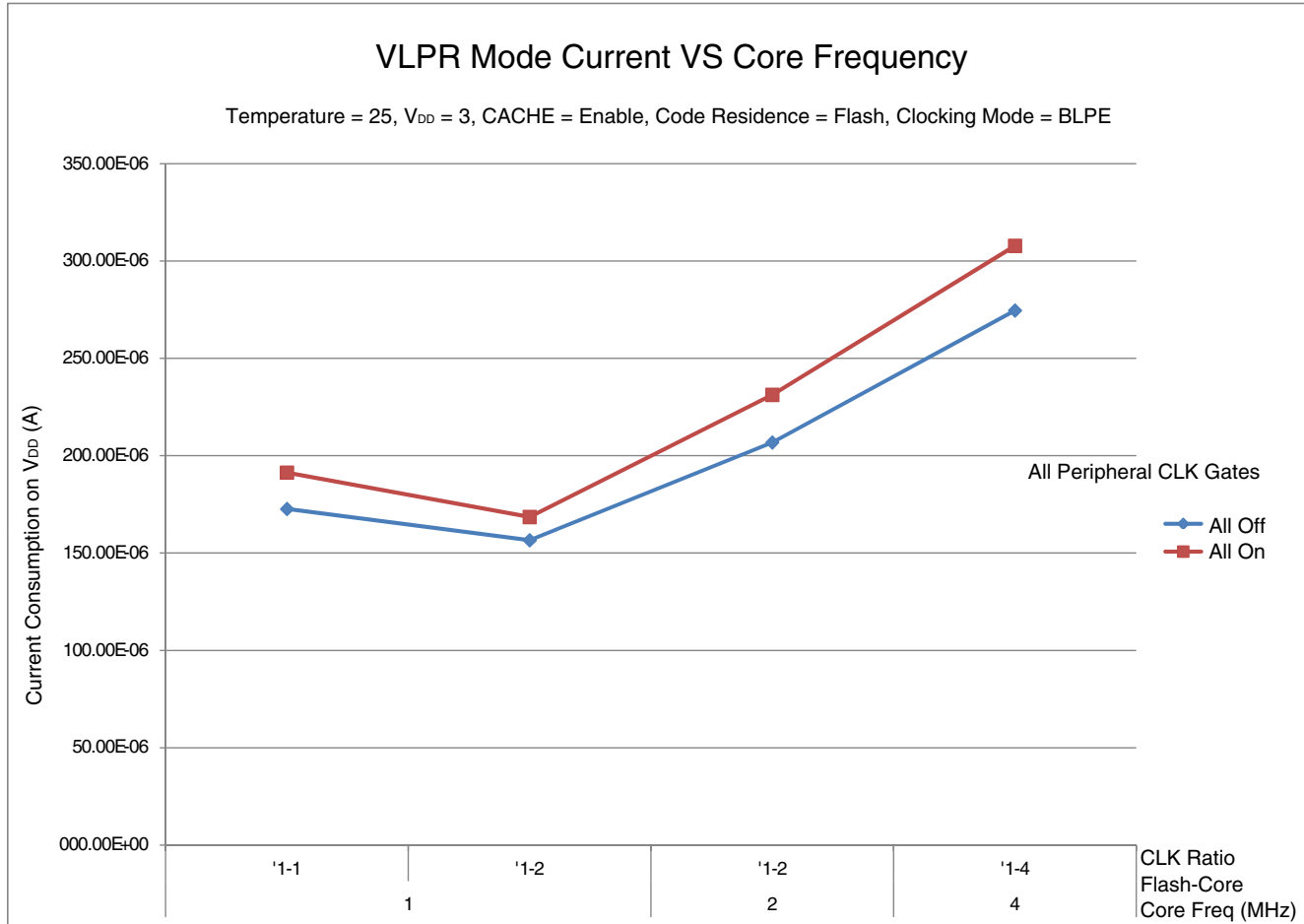

Figure 3. VLPR mode current vs. core frequency

2.2.6 EMC radiated emissions operating behaviors

Table 11. EMC radiated emissions operating behaviors for 32-pin QFN package

Symbol	Description	Frequency band (MHz)	Typ.	Unit	Notes
V _{RE1}	Radiated emissions voltage, band 1	0.15–50	7	dBμV	1, 2
V _{RE2}	Radiated emissions voltage, band 2	50–150	6	dBμV	
V _{RE3}	Radiated emissions voltage, band 3	150–500	4	dBμV	
V _{RE4}	Radiated emissions voltage, band 4	500–1000	4	dBμV	
V _{RE_IEC}	IEC level	0.15–1000	N	—	2, 3

1. Determined according to IEC Standard 61967-1, *Integrated Circuits - Measurement of Electromagnetic Emissions, 150 kHz to 1 GHz Part 1: General Conditions and Definitions* and IEC Standard 61967-2, *Integrated Circuits - Measurement of Electromagnetic Emissions, 150 kHz to 1 GHz Part 2: Measurement of Radiated Emissions—TEM Cell and Wideband TEM Cell Method*. Measurements were made while the microcontroller was running basic application code.

The reported emission level is the value of the maximum measured emission, rounded up to the next whole number, from among the measured orientations in each frequency range.

2. $V_{DD} = 3.3\text{ V}$, $T_A = 25\text{ }^\circ\text{C}$, $f_{OSC} = 32.768\text{ kHz}$ (crystal), $f_{SYS} = 48\text{ MHz}$, $f_{BUS} = 24\text{ MHz}$
3. Specified according to Annex D of IEC Standard 61967-2, *Measurement of Radiated Emissions—TEM Cell and Wideband TEM Cell Method*

2.2.7 Designing with radiated emissions in mind

To find application notes that provide guidance on designing your system to minimize interference from radiated emissions:

1. Go to www.freescale.com.
2. Perform a keyword search for “EMC design.”

2.2.8 Capacitance attributes

Table 12. Capacitance attributes

Symbol	Description	Min.	Max.	Unit
C_{IN}	Input capacitance	—	7	pF

2.3 Switching specifications

2.3.1 Device clock specifications

Table 13. Device clock specifications

Symbol	Description	Min.	Max.	Unit
Normal run mode				
f_{SYS}	System and core clock	—	48	MHz
f_{BUS}	Bus clock	—	24	MHz
f_{FLASH}	Flash clock	—	24	MHz
f_{LPTMR}	LPTMR clock	—	24	MHz
VLPR and VLPS modes ¹				
f_{SYS}	System and core clock	—	4	MHz
f_{BUS}	Bus clock	—	1	MHz
f_{FLASH}	Flash clock	—	1	MHz
f_{LPTMR}	LPTMR clock ²	—	24	MHz
f_{ERCLK}	External reference clock	—	32.768	kHz

Table continues on the next page...

Table 13. Device clock specifications (continued)

Symbol	Description	Min.	Max.	Unit
f_{LPTMR_ERCLK}	LPTMR external reference clock	—	16	MHz
f_{TPM}	TPM asynchronous clock	—	8	MHz
f_{UART0}	UART0 asynchronous clock	—	8	MHz

1. The frequency limitations in VLPR and VLPS modes here override any frequency specification listed in the timing specification for any other module. These same frequency limits apply to VLPS, whether VLPS was entered from RUN or from VLPR.
2. The LPTMR can be clocked at this speed in VLPR or VLPS only when the source is an external pin.

2.3.2 General switching specifications

These general-purpose specifications apply to all signals configured for GPIO and UART signals.

Table 14. General switching specifications

Description	Min.	Max.	Unit	Notes
GPIO pin interrupt pulse width (digital glitch filter disabled) — Synchronous path	1.5	—	Bus clock cycles	1
External RESET and NMI pin interrupt pulse width — Asynchronous path	100	—	ns	2
GPIO pin interrupt pulse width — Asynchronous path	16	—	ns	2
Port rise and fall time	—	36	ns	3

1. The greater synchronous and asynchronous timing must be met.
2. This is the shortest pulse that is guaranteed to be recognized.
3. 75 pF load

2.4 Thermal specifications

2.4.1 Thermal operating requirements

Table 15. Thermal operating requirements

Symbol	Description	Min.	Max.	Unit
T_J	Die junction temperature	–40	125	°C
T_A	Ambient temperature	–40	105	°C

2.4.2 Thermal attributes

Table 16. Thermal attributes

Board type	Symbol	Description	16 QFN	24 QFN	32 QFN	Unit	Notes
Single-layer (1S)	$R_{\theta JA}$	Thermal resistance, junction to ambient (natural convection)	141	114	101	°C/W	1
Four-layer (2s2p)	$R_{\theta JA}$	Thermal resistance, junction to ambient (natural convection)	55	42	35	°C/W	
Single-layer (1S)	$R_{\theta JMA}$	Thermal resistance, junction to ambient (200 ft./min. air speed)	120	96	84	°C/W	
Four-layer (2s2p)	$R_{\theta JMA}$	Thermal resistance, junction to ambient (200 ft./min. air speed)	49	36	30	°C/W	
—	$R_{\theta JB}$	Thermal resistance, junction to board	27	19	15	°C/W	2
—	$R_{\theta JC}$	Thermal resistance, junction to case	20	3.4	3.4	°C/W	3
—	Ψ_{JT}	Thermal characterization parameter, junction to package top outside center (natural convection)	23	15	11	°C/W	4

1. Determined according to JEDEC Standard JESD51-2, *Integrated Circuits Thermal Test Method Environmental Conditions—Natural Convection (Still Air)*, or EIA/JEDEC Standard JESD51-6, *Integrated Circuit Thermal Test Method Environmental Conditions—Forced Convection (Moving Air)*.
2. Determined according to JEDEC Standard JESD51-8, *Integrated Circuit Thermal Test Method Environmental Conditions—Junction-to-Board*.
3. Determined according to Method 1012.1 of MIL-STD 883, *Test Method Standard, Microcircuits*, with the cold plate temperature used for the case temperature. The value includes the thermal resistance of the interface material between the top of the package and the cold plate.
4. Determined according to JEDEC Standard JESD51-2, *Integrated Circuits Thermal Test Method Environmental Conditions—Natural Convection (Still Air)*.

3 Peripheral operating requirements and behaviors

3.1 Core modules

3.1.1 SWD electricals

Table 17. SWD full voltage range electricals

Symbol	Description	Min.	Max.	Unit
	Operating voltage	1.71	3.6	V
J1	SWD_CLK frequency of operation	0	25	MHz

Table continues on the next page...

Table 17. SWD full voltage range electricals (continued)

Symbol	Description	Min.	Max.	Unit
	• Serial wire debug			
J2	SWD_CLK cycle period	1/J1	—	ns
J3	SWD_CLK clock pulse width • Serial wire debug	20	—	ns
J4	SWD_CLK rise and fall times	—	3	ns
J9	SWD_DIO input data setup time to SWD_CLK rise	10	—	ns
J10	SWD_DIO input data hold time after SWD_CLK rise	0	—	ns
J11	SWD_CLK high to SWD_DIO data valid	—	32	ns
J12	SWD_CLK high to SWD_DIO high-Z	5	—	ns

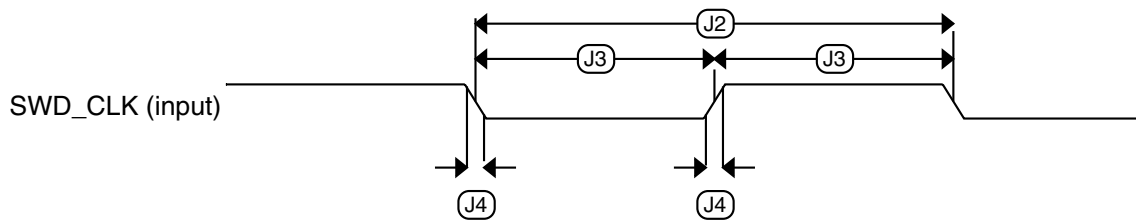

Figure 4. Serial wire clock input timing

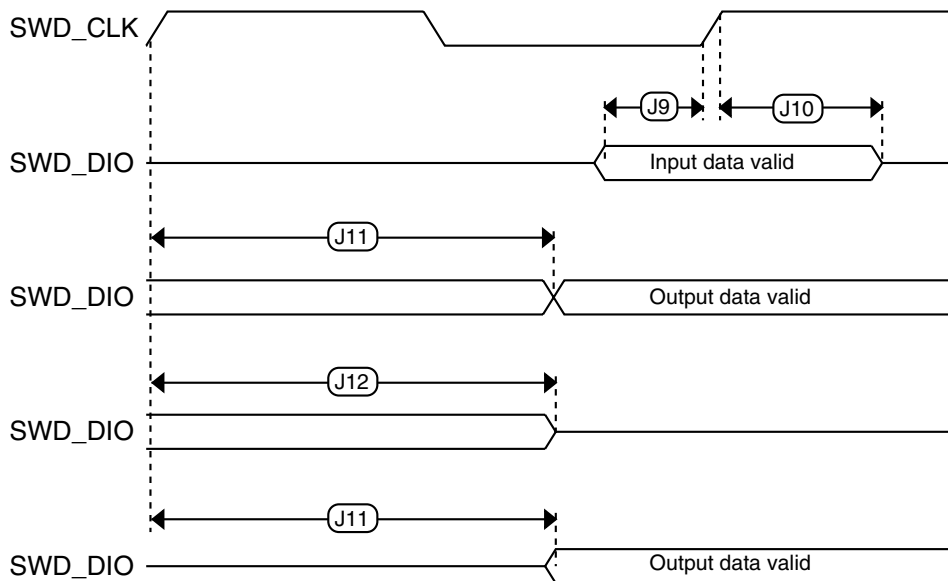

Figure 5. Serial wire data timing

3.2 System modules

There are no specifications necessary for the device's system modules.

3.3 Clock modules

3.3.1 MCG specifications

Table 18. MCG specifications

Symbol	Description	Min.	Typ.	Max.	Unit	Notes	
f_{ints_ft}	Internal reference frequency (slow clock) — factory trimmed at nominal V_{DD} and 25 °C	—	32.768	—	kHz		
f_{ints_t}	Internal reference frequency (slow clock) — user trimmed	31.25	—	39.0625	kHz		
$\Delta f_{dco_res_t}$	Resolution of trimmed average DCO output frequency at fixed voltage and temperature — using C3[SCTTRIM] and C4[SCFTRIM]	—	± 0.3	± 0.6	% f_{dco}	1	
Δf_{dco_t}	Total deviation of trimmed average DCO output frequency over voltage and temperature	—	+0.5/-0.7	± 3	% f_{dco}	1, 2	
Δf_{dco_t}	Total deviation of trimmed average DCO output frequency over fixed voltage and temperature range of 0–70 °C	—	± 0.4	± 1.5	% f_{dco}	1, 2	
f_{intf_ft}	Internal reference frequency (fast clock) — factory trimmed at nominal V_{DD} and 25 °C	—	4	—	MHz		
Δf_{intf_ft}	Frequency deviation of internal reference clock (fast clock) over temperature and voltage — factory trimmed at nominal V_{DD} and 25 °C	—	+1/-2	± 3	% f_{intf_ft}	2	
f_{intf_t}	Internal reference frequency (fast clock) — user trimmed at nominal V_{DD} and 25 °C	3	—	5	MHz		
f_{loc_low}	Loss of external clock minimum frequency — RANGE = 00	$(3/5) \times f_{ints_t}$	—	—	kHz		
f_{loc_high}	Loss of external clock minimum frequency — RANGE = 01, 10, or 11	$(16/5) \times f_{ints_t}$	—	—	kHz		
FLL							
f_{fill_ref}	FLL reference frequency range	31.25	—	39.0625	kHz		
f_{dco}	DCO output frequency range	Low range (DRS = 00) $640 \times f_{fill_ref}$	20	20.97	25	MHz	3, 4
		Mid range (DRS = 01) $1280 \times f_{fill_ref}$	40	41.94	48	MHz	
$f_{dco_t_DMX3_2}$	DCO output frequency	Low range (DRS = 00)	—	23.99	—	MHz	5, 6

Table continues on the next page...

Table 18. MCG specifications (continued)

Symbol	Description	Min.	Typ.	Max.	Unit	Notes
J_{cyc_fll}	FLL period jitter • $f_{VCO} = 48$ MHz	—	180	—	ps	7
$t_{fll_acquire}$	FLL target frequency acquisition time	—	—	1	ms	8

1. This parameter is measured with the internal reference (slow clock) being used as a reference to the FLL (FEI clock mode).
2. The deviation is relative to the factory trimmed frequency at nominal V_{DD} and 25 °C, f_{ints_ft} .
3. These typical values listed are with the slow internal reference clock (FEI) using factory trim and DMX32 = 0.
4. The resulting system clock frequencies must not exceed their maximum specified values. The DCO frequency deviation (Δf_{dco_t}) over voltage and temperature must be considered.
5. These typical values listed are with the slow internal reference clock (FEI) using factory trim and DMX32 = 1.
6. The resulting clock frequency must not exceed the maximum specified clock frequency of the device.
7. This specification is based on standard deviation (RMS) of period or frequency.
8. This specification applies to any time the FLL reference source or reference divider is changed, trim value is changed, DMX32 bit is changed, DRS bits are changed, or changing from FLL disabled (BLPE, BLPI) to FLL enabled (FEI, FEE, FBE, FBI). If a crystal/resonator is being used as the reference, this specification assumes it is already running.

3.3.2 Oscillator electrical specifications

3.3.2.1 Oscillator DC electrical specifications

Table 19. Oscillator DC electrical specifications

Symbol	Description	Min.	Typ.	Max.	Unit	Notes
V_{DD}	Supply voltage	1.71	—	3.6	V	
I_{DDOSC}	Supply current — low-power mode (HGO=0) • 32 kHz	—	500	—	nA	1
I_{DDOSC}	Supply current — high gain mode (HGO=1) • 32 kHz	—	25	—	μ A	1
C_x	EXTAL load capacitance	—	—	—		2, 3
C_y	XTAL load capacitance	—	—	—		2, 3
R_F	Feedback resistor — low-frequency, low-power mode (HGO=0)	—	—	—	M Ω	2, 4
	Feedback resistor — low-frequency, high-gain mode (HGO=1)	—	10	—	M Ω	
R_S	Series resistor — low-frequency, low-power mode (HGO=0)	—	—	—	k Ω	

Table continues on the next page...

Table 19. Oscillator DC electrical specifications (continued)

Symbol	Description	Min.	Typ.	Max.	Unit	Notes
	Series resistor — low-frequency, high-gain mode (HGO=1)	—	200	—	k Ω	
V_{pp} ⁵	Peak-to-peak amplitude of oscillation (oscillator mode) — low-frequency, low-power mode (HGO=0)	—	0.6	—	V	
	Peak-to-peak amplitude of oscillation (oscillator mode) — low-frequency, high-gain mode (HGO=1)	—	V_{DD}	—	V	

1. V_{DD} =3.3 V, Temperature =25 °C
2. See crystal or resonator manufacturer's recommendation
3. C_x, C_y can be provided by using either the integrated capacitors or by using external components.
4. When low power mode is selected, R_F is integrated and must not be attached externally.
5. The EXTAL and XTAL pins should only be connected to required oscillator components and must not be connected to any other devices.

3.3.2.2 Oscillator frequency specifications

Table 20. Oscillator frequency specifications

Symbol	Description	Min.	Typ.	Max.	Unit	Notes
f_{osc_lo}	Oscillator crystal or resonator frequency — low frequency mode (MCG_C2[RANGE]=00)	32	—	40	kHz	
t_{dc_extal}	Input clock duty cycle (external clock mode)	40	50	60	%	
t_{cst}	Crystal startup time — 32 kHz low-frequency, low-power mode (HGO=0)	—		—	ms	1, 2
	Crystal startup time — 32 kHz low-frequency, high-gain mode (HGO=1)	—		—	ms	

1. Proper PC board layout procedures must be followed to achieve specifications.
2. Crystal startup time is defined as the time between the oscillator being enabled and the OSCINIT bit in the MCG_S register being set.

3.4 Memories and memory interfaces

3.4.1 Flash electrical specifications

This section describes the electrical characteristics of the flash memory module.

3.4.1.1 Flash timing specifications — program and erase

The following specifications represent the amount of time the internal charge pumps are active and do not include command overhead.

Table 21. NVM program/erase timing specifications

Symbol	Description	Min.	Typ.	Max.	Unit	Notes
$t_{hvp\text{gm}4}$	Longword Program high-voltage time	—	7.5	18	μs	
$t_{h\text{versscr}}$	Sector Erase high-voltage time	—	13	113	ms	1
$t_{h\text{versall}}$	Erase All high-voltage time	—	52	452	ms	1

1. Maximum time based on expectations at cycling end-of-life.

3.4.1.2 Flash timing specifications — commands

Table 22. Flash command timing specifications

Symbol	Description	Min.	Typ.	Max.	Unit	Notes
$t_{rd1\text{sec}1\text{k}}$	Read 1s Section execution time (flash sector)	—	—	60	μs	1
$t_{pgm\text{chk}}$	Program Check execution time	—	—	45	μs	1
$t_{rd\text{rsrc}}$	Read Resource execution time	—	—	30	μs	1
t_{pgm4}	Program Longword execution time	—	65	145	μs	
$t_{er\text{sscr}}$	Erase Flash Sector execution time	—	14	114	ms	2
$t_{rd1\text{all}}$	Read 1s All Blocks execution time	—	—	0.5	ms	
$t_{rd\text{once}}$	Read Once execution time	—	—	25	μs	1
$t_{pgm\text{once}}$	Program Once execution time	—	65	—	μs	
$t_{er\text{sall}}$	Erase All Blocks execution time	—	61	500	ms	2
t_{vfykey}	Verify Backdoor Access Key execution time	—	—	30	μs	1

1. Assumes 25 MHz flash clock frequency.
2. Maximum times for erase parameters based on expectations at cycling end-of-life.

3.4.1.3 Flash high voltage current behaviors

Table 23. Flash high voltage current behaviors

Symbol	Description	Min.	Typ.	Max.	Unit
I_{DD_PGM}	Average current adder during high voltage flash programming operation	—	2.5	6.0	mA
I_{DD_ERS}	Average current adder during high voltage flash erase operation	—	1.5	4.0	mA

3.4.1.4 Reliability specifications

Table 24. NVM reliability specifications

Symbol	Description	Min.	Typ. ¹	Max.	Unit	Notes
Program Flash						
$t_{\text{nv mretp10k}}$	Data retention after up to 10 K cycles	5	50	—	years	
$t_{\text{nv mretp1k}}$	Data retention after up to 1 K cycles	20	100	—	years	
$n_{\text{nv mcycp}}$	Cycling endurance	10 K	50 K	—	cycles	2

1. Typical data retention values are based on measured response accelerated at high temperature and derated to a constant 25 °C use profile. Engineering Bulletin EB618 does not apply to this technology. Typical endurance defined in Engineering Bulletin EB619.
2. Cycling endurance represents number of program/erase cycles at $-40\text{ °C} \leq T_j \leq 125\text{ °C}$.

3.5 Security and integrity modules

There are no specifications necessary for the device's security and integrity modules.

3.6 Analog

3.6.1 ADC electrical specifications

All ADC channels meet the 12-bit single-ended accuracy specifications.

3.6.1.1 12-bit ADC operating conditions

Table 25. 12-bit ADC operating conditions

Symbol	Description	Conditions	Min.	Typ. ¹	Max.	Unit	Notes
V_{DDA}	Supply voltage	Absolute	1.71	—	3.6	V	
ΔV_{DDA}	Supply voltage	Delta to V_{DD} ($V_{\text{DD}} - V_{\text{DDA}}$)	-100	0	+100	mV	2
ΔV_{SSA}	Ground voltage	Delta to V_{SS} ($V_{\text{SS}} - V_{\text{SSA}}$)	-100	0	+100	mV	2
V_{REFH}	ADC reference voltage high		1.13	V_{DDA}	V_{DDA}	V	3
V_{REFL}	ADC reference voltage low		V_{SSA}	V_{SSA}	V_{SSA}	V	3
V_{ADIN}	Input voltage		V_{REFL}	—	V_{REFH}	V	
C_{ADIN}	Input capacitance	• 8-bit / 10-bit / 12-bit modes	—	4	5	pF	
R_{ADIN}	Input series resistance		—	2	5	k Ω	

Table continues on the next page...

Table 25. 12-bit ADC operating conditions (continued)

Symbol	Description	Conditions	Min.	Typ. ¹	Max.	Unit	Notes
R_{AS}	Analog source resistance (external)	12-bit modes $f_{ADCK} < 4$ MHz	—	—	5	k Ω	4
f_{ADCK}	ADC conversion clock frequency	\leq 12-bit mode	1.0	—	18.0	MHz	5
C_{rate}	ADC conversion rate	\leq 12-bit modes No ADC hardware averaging Continuous conversions enabled, subsequent conversion time	20.000	—	818.330	Ksps	6

1. Typical values assume $V_{DDA} = 3.0$ V, Temp = 25 °C, $f_{ADCK} = 1.0$ MHz, unless otherwise stated. Typical values are for reference only, and are not tested in production.
2. DC potential difference.
3. For packages without dedicated VREFH and VREFL pins, V_{REFH} is internally tied to V_{DDA} , and V_{REFL} is internally tied to V_{SSA} .
4. This resistance is external to MCU. To achieve the best results, the analog source resistance must be kept as low as possible. The results in this data sheet were derived from a system that had $< 8 \Omega$ analog source resistance. The R_{AS}/C_{AS} time constant should be kept to < 1 ns.
5. To use the maximum ADC conversion clock frequency, CFG2[ADHSC] must be set and CFG1[ADLPC] must be clear.
6. For guidelines and examples of conversion rate calculation, download the [ADC calculator tool](#).

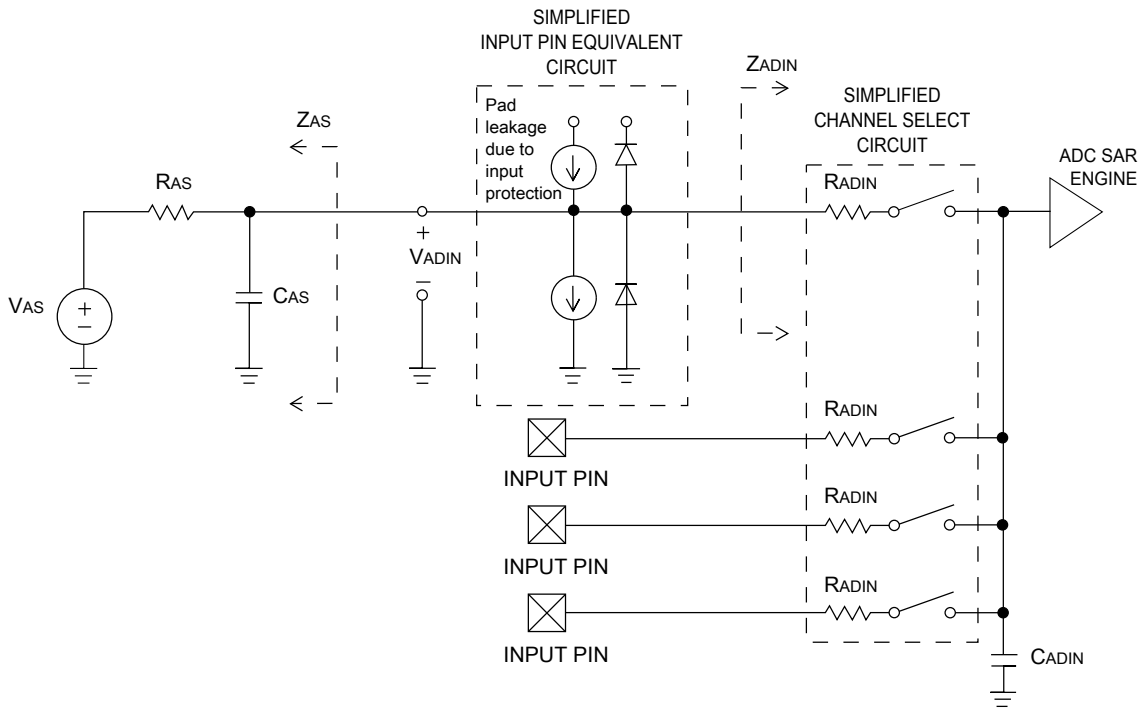

Figure 6. ADC input impedance equivalency diagram

3.6.1.2 12-bit ADC electrical characteristics

Table 26. 12-bit ADC characteristics ($V_{REFH} = V_{DDA}$, $V_{REFL} = V_{SSA}$)

Symbol	Description	Conditions ¹	Min.	Typ. ²	Max.	Unit	Notes
I_{DDA_ADC}	Supply current		0.215	—	1.7	mA	3
f_{ADACK}	ADC asynchronous clock source	• ADLPC = 1, ADHSC = 0	1.2	2.4	3.9	MHz	$t_{ADACK} = 1/f_{ADACK}$
		• ADLPC = 1, ADHSC = 1	2.4	4.0	6.1	MHz	
		• ADLPC = 0, ADHSC = 0	3.0	5.2	7.3	MHz	
		• ADLPC = 0, ADHSC = 1	4.4	6.2	9.5	MHz	
	Sample Time	See Reference Manual chapter for sample times					
TUE	Total unadjusted error	• 12-bit modes	—	±4	±6.8	LSB ⁴	5
		• <12-bit modes	—	±1.4	±2.1		
DNL	Differential non-linearity	• 12-bit modes	—	±0.7	−1.1 to +1.9	LSB ⁴	5
		• <12-bit modes	—	±0.2	−0.3 to 0.5		
INL	Integral non-linearity	• 12-bit modes	—	±1.0	−2.7 to +1.9	LSB ⁴	5
		• <12-bit modes	—	±0.5	−0.7 to +0.5		
E_{FS}	Full-scale error	• 12-bit modes	—	−4	−5.4	LSB ⁴	$V_{ADIN} = V_{DDA}$ ⁵
		• <12-bit modes	—	−1.4	−1.8		
E_Q	Quantization error	• 12-bit modes	—	—	±0.5	LSB ⁴	
E_{IL}	Input leakage error		$I_{in} \times R_{AS}$			mV	I_{in} = leakage current (refer to the MCU's voltage and current operating ratings)
	Temp sensor slope	Across the full temperature range of the device	1.55	1.62	1.69	mV/°C	6
V_{TEMP25}	Temp sensor voltage	25 °C	706	716	726	mV	6

1. All accuracy numbers assume the ADC is calibrated with $V_{REFH} = V_{DDA}$

2. Typical values assume $V_{DDA} = 3.0$ V, Temp = 25 °C, $f_{ADCK} = 2.0$ MHz unless otherwise stated. Typical values are for reference only and are not tested in production.

Peripheral operating requirements and behaviors

3. The ADC supply current depends on the ADC conversion clock speed, conversion rate and ADC_CFG1[ADLPC] (low power). For lowest power operation, ADC_CFG1[ADLPC] must be set, the ADC_CFG2[ADHSC] bit must be clear with 1 MHz ADC conversion clock speed.
4. $1 \text{ LSB} = (V_{\text{REFH}} - V_{\text{REFL}})/2^N$
5. ADC conversion clock < 16 MHz, Max hardware averaging (AVGE = %1, AVGS = %11)
6. ADC conversion clock < 3 MHz

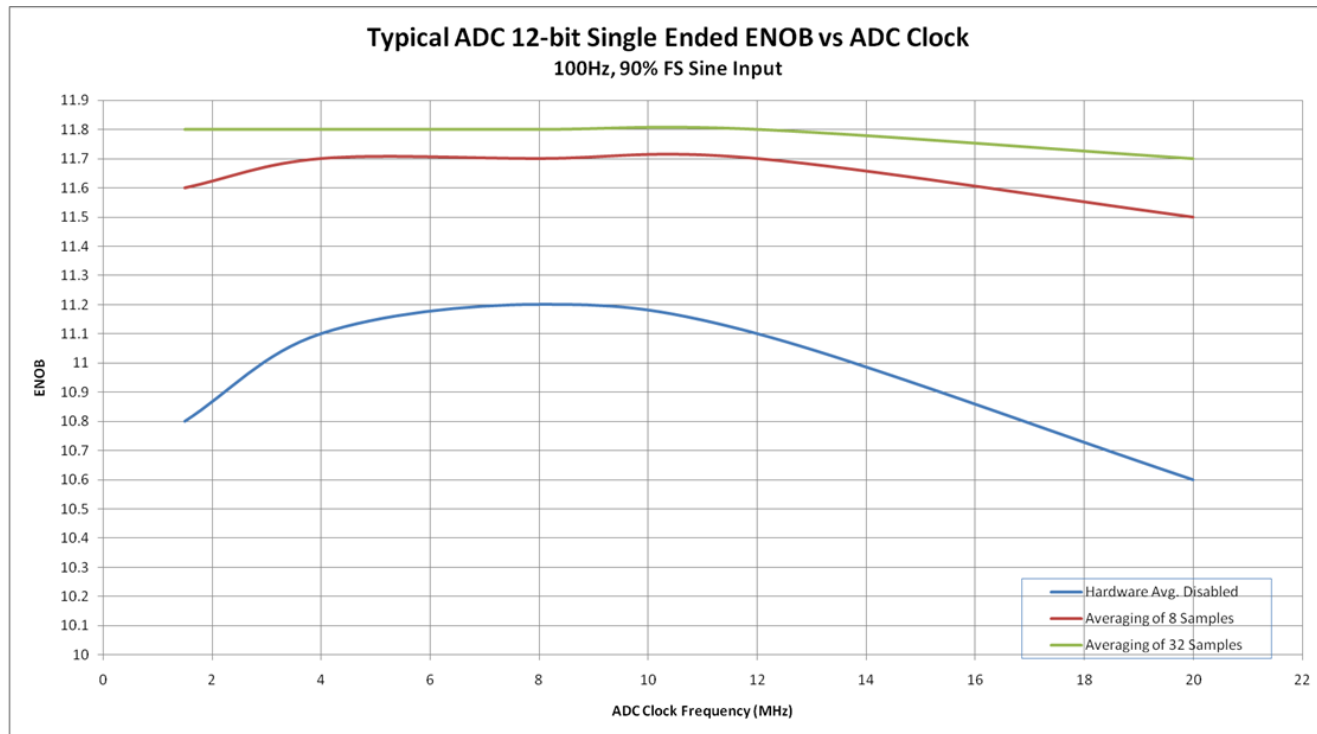

Figure 7. Typical ENOB vs. ADC_CLK for 12-bit single-ended mode

3.6.2 CMP and 6-bit DAC electrical specifications

Table 27. Comparator and 6-bit DAC electrical specifications

Symbol	Description	Min.	Typ.	Max.	Unit
V_{DD}	Supply voltage	1.71	—	3.6	V
I_{DDHS}	Supply current, High-speed mode (EN=1, PMODE=1)	—	—	200	μA
I_{DDL}	Supply current, low-speed mode (EN=1, PMODE=0)	—	—	20	μA
V_{AIN}	Analog input voltage	$V_{\text{SS}} - 0.3$	—	V_{DD}	V
V_{AIO}	Analog input offset voltage	—	—	20	mV
V_{H}	Analog comparator hysteresis ¹				
	• CR0[HYSTCTR] = 00	—	5	—	mV
	• CR0[HYSTCTR] = 01	—	10	—	mV
		—	20	—	mV
		—	30	—	mV

Table continues on the next page...

Table 27. Comparator and 6-bit DAC electrical specifications (continued)

Symbol	Description	Min.	Typ.	Max.	Unit
	<ul style="list-style-type: none"> CR0[HYSTCTR] = 10 CR0[HYSTCTR] = 11 				
V_{CMPOH}	Output high	$V_{DD} - 0.5$	—	—	V
V_{CMPOI}	Output low	—	—	0.5	V
t_{DHS}	Propagation delay, high-speed mode (EN=1, PMODE=1)	20	50	200	ns
t_{DLS}	Propagation delay, low-speed mode (EN=1, PMODE=0)	80	250	600	ns
	Analog comparator initialization delay ²	—	—	40	μ s
I_{DAC6b}	6-bit DAC current adder (enabled)	—	7	—	μ A
INL	6-bit DAC integral non-linearity	-0.5	—	0.5	LSB ³
DNL	6-bit DAC differential non-linearity	-0.3	—	0.3	LSB

1. Typical hysteresis is measured with input voltage range limited to 0.6 to $V_{DD}-0.6$ V.
2. Comparator initialization delay is defined as the time between software writes to change control inputs (Writes to CMP_DACCR[DACEN], CMP_DACCR[VRSEL], CMP_DACCR[VOSEL], CMP_MUXCR[PSEL], and CMP_MUXCR[MSEL]) and the comparator output settling to a stable level.
3. 1 LSB = $V_{reference}/64$

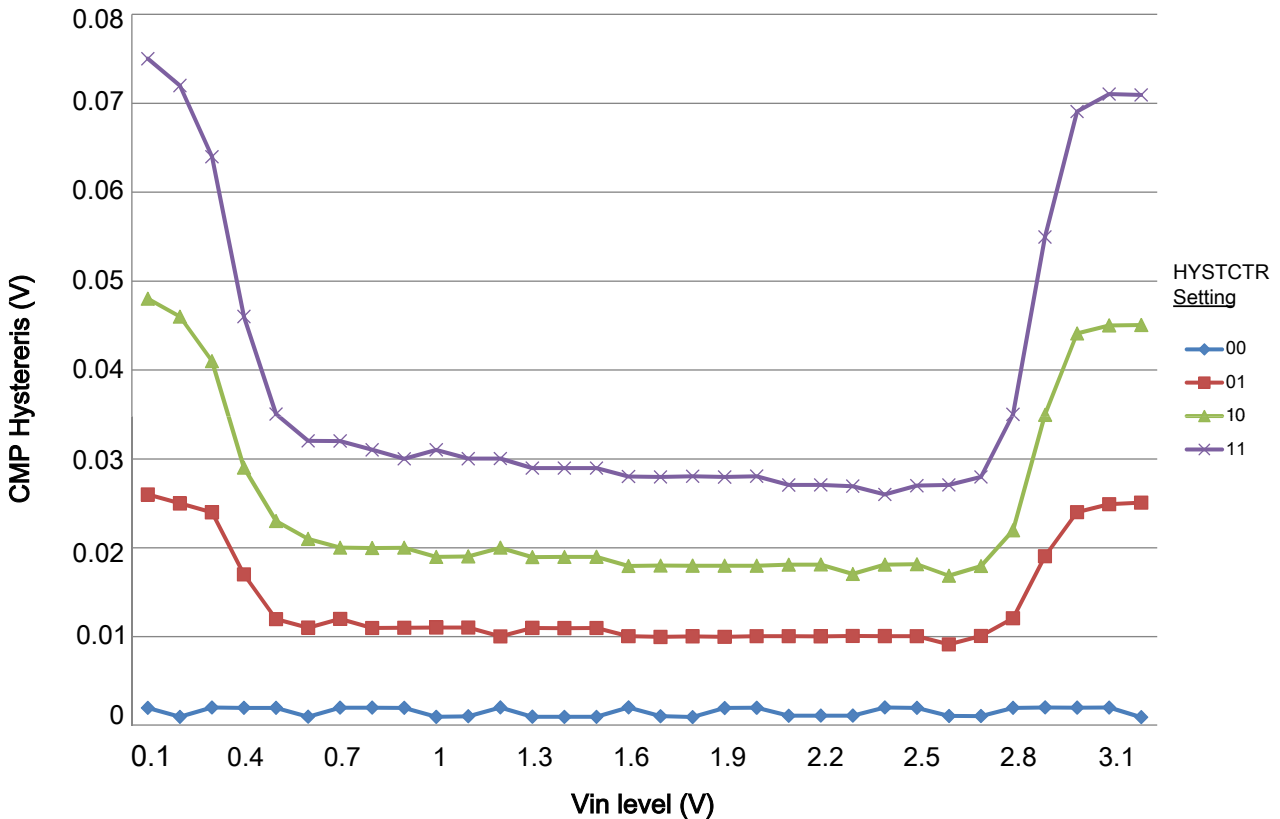
**Figure 8. Typical hysteresis vs. Vin level (VDD = 3.3 V, PMODE = 0)**

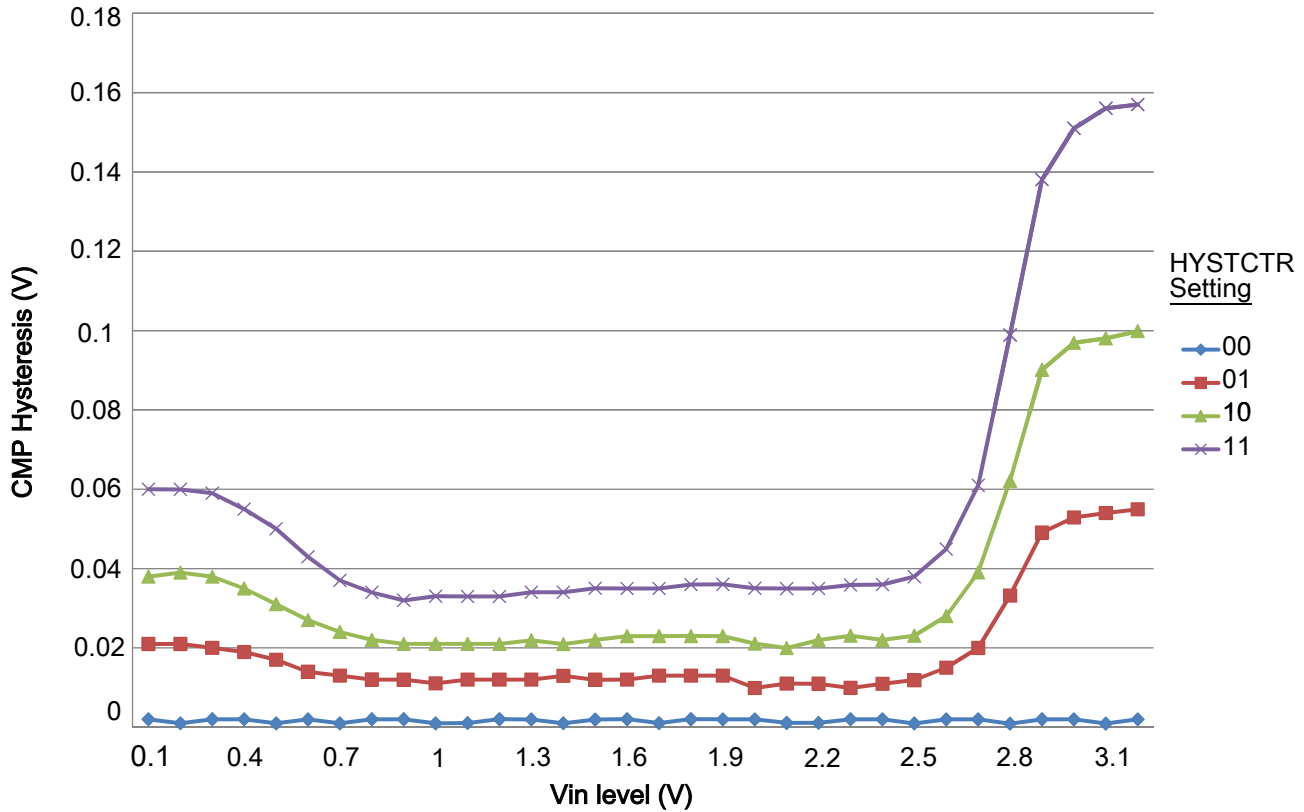

Figure 9. Typical hysteresis vs. Vin level (VDD = 3.3 V, PMODE = 1)

3.7 Timers

See [General switching specifications](#).

3.8 Communication interfaces

3.8.1 SPI switching specifications

The Serial Peripheral Interface (SPI) provides a synchronous serial bus with master and slave operations. Many of the transfer attributes are programmable. The following tables provide timing characteristics for classic SPI timing modes. See the SPI chapter of the chip's Reference Manual for information about the modified transfer formats used for communicating with slower peripheral devices.

All timing is shown with respect to 20% V_{DD} and 80% V_{DD} thresholds, unless noted, as well as input signal transitions of 3 ns and a 30 pF maximum load on all SPI pins.

Table 28. SPI master mode timing on slew rate disabled pads

Num.	Symbol	Description	Min.	Max.	Unit	Note
1	f_{op}	Frequency of operation	$f_{periph}/2048$	$f_{periph}/2$	Hz	1
2	t_{SPSCK}	SPSCK period	$2 \times t_{periph}$	$2048 \times t_{periph}$	ns	2
3	t_{Lead}	Enable lead time	1/2	—	t_{SPSCK}	—
4	t_{Lag}	Enable lag time	1/2	—	t_{SPSCK}	—
5	t_{WSPSCK}	Clock (SPSCK) high or low time	$t_{periph} - 30$	$1024 \times t_{periph}$	ns	—
6	t_{SU}	Data setup time (inputs)	19.5	—	ns	—
7	t_{HI}	Data hold time (inputs)	0	—	ns	—
8	t_v	Data valid (after SPSCK edge)	—	10	ns	—
9	t_{HO}	Data hold time (outputs)	0	—	ns	—
10	t_{RI}	Rise time input	—	$t_{periph} - 25$	ns	—
	t_{FI}	Fall time input				
11	t_{RO}	Rise time output	—	25	ns	—
	t_{FO}	Fall time output				

1. For SPI0, f_{periph} is the bus clock (f_{BUS}).
2. $t_{periph} = 1/f_{periph}$

Table 29. SPI master mode timing on slew rate enabled pads

Num.	Symbol	Description	Min.	Max.	Unit	Note
1	f_{op}	Frequency of operation	$f_{periph}/2048$	$f_{periph}/2$	Hz	1
2	t_{SPSCK}	SPSCK period	$2 \times t_{periph}$	$2048 \times t_{periph}$	ns	2
3	t_{Lead}	Enable lead time	1/2	—	t_{SPSCK}	—
4	t_{Lag}	Enable lag time	1/2	—	t_{SPSCK}	—
5	t_{WSPSCK}	Clock (SPSCK) high or low time	$t_{periph} - 30$	$1024 \times t_{periph}$	ns	—
6	t_{SU}	Data setup time (inputs)	96	—	ns	—
7	t_{HI}	Data hold time (inputs)	0	—	ns	—
8	t_v	Data valid (after SPSCK edge)	—	52	ns	—
9	t_{HO}	Data hold time (outputs)	0	—	ns	—
10	t_{RI}	Rise time input	—	$t_{periph} - 25$	ns	—
	t_{FI}	Fall time input				
11	t_{RO}	Rise time output	—	36	ns	—
	t_{FO}	Fall time output				

1. For SPI0, f_{periph} is the bus clock (f_{BUS}).
2. $t_{periph} = 1/f_{periph}$

Peripheral operating requirements and behaviors

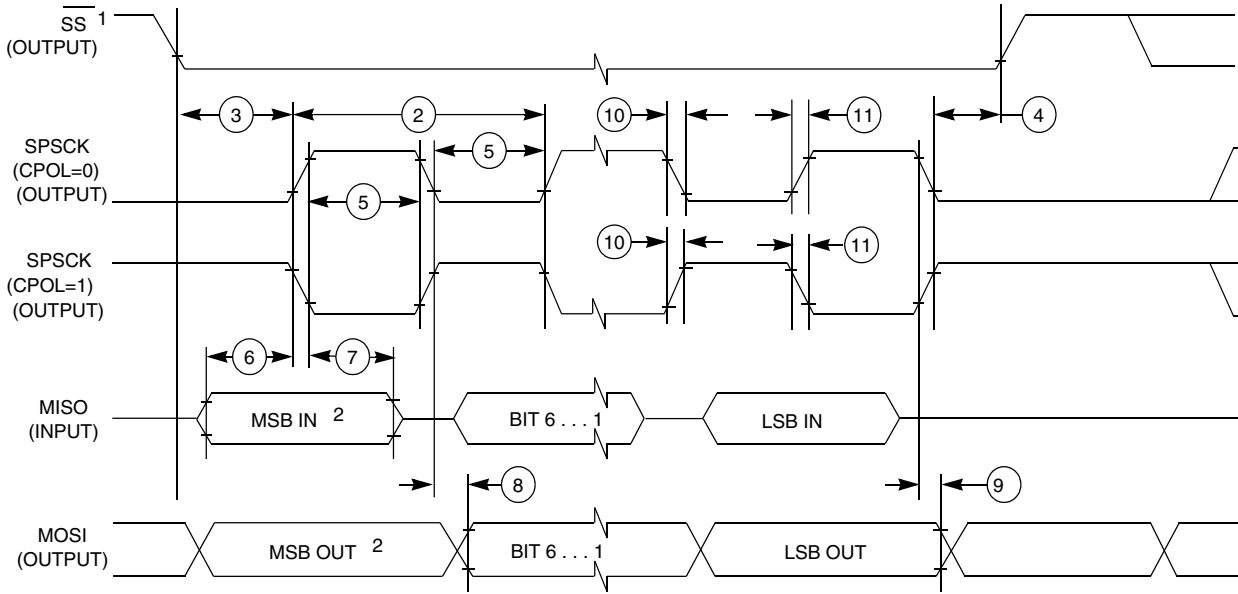

- 1. If configured as an output.
- 2. LSBF = 0. For LSBF = 1, bit order is LSB, bit 1, ..., bit 6, MSB.

Figure 10. SPI master mode timing (CPHA = 0)

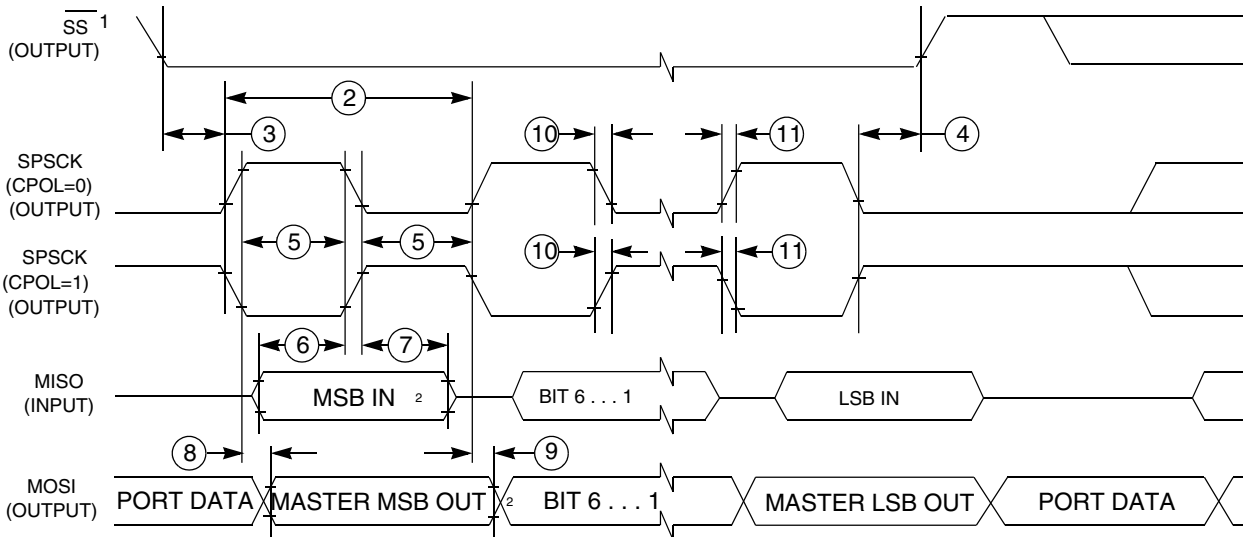

- 1. If configured as output
- 2. LSBF = 0. For LSBF = 1, bit order is LSB, bit 1, ..., bit 6, MSB.

Figure 11. SPI master mode timing (CPHA = 1)

Table 30. SPI slave mode timing on slew rate disabled pads

Num.	Symbol	Description	Min.	Max.	Unit	Note
1	f_{op}	Frequency of operation	0	$f_{periph}/4$	Hz	1
2	t_{SPSCCK}	SPSCCK period	$4 \times t_{periph}$	—	ns	2
3	t_{Lead}	Enable lead time	1	—	t_{periph}	—

Table continues on the next page...

Table 30. SPI slave mode timing on slew rate disabled pads (continued)

Num.	Symbol	Description	Min.	Max.	Unit	Note
4	t_{Lag}	Enable lag time	1	—	t_{periph}	—
5	t_{WSPSCK}	Clock (SPSCK) high or low time	$t_{periph} - 30$	—	ns	—
6	t_{SU}	Data setup time (inputs)	2	—	ns	—
7	t_{HI}	Data hold time (inputs)	7	—	ns	—
8	t_a	Slave access time	—	t_{periph}	ns	3
9	t_{dis}	Slave MISO disable time	—	t_{periph}	ns	4
10	t_v	Data valid (after SPSCK edge)	—	25	ns	—
11	t_{HO}	Data hold time (outputs)	0	—	ns	—
12	t_{RI}	Rise time input	—	$t_{periph} - 25$	ns	—
	t_{FI}	Fall time input				
13	t_{RO}	Rise time output	—	25	ns	—
	t_{FO}	Fall time output				

1. For SPI0, f_{periph} is the bus clock (f_{BUS}).
2. $t_{periph} = 1/f_{periph}$
3. Time to data active from high-impedance state
4. Hold time to high-impedance state

Table 31. SPI slave mode timing on slew rate enabled pads

Num.	Symbol	Description	Min.	Max.	Unit	Note
1	f_{op}	Frequency of operation	0	$f_{periph}/4$	Hz	1
2	t_{SPSCK}	SPSCK period	$4 \times t_{periph}$	—	ns	2
3	t_{Lead}	Enable lead time	1	—	t_{periph}	—
4	t_{Lag}	Enable lag time	1	—	t_{periph}	—
5	t_{WSPSCK}	Clock (SPSCK) high or low time	$t_{periph} - 30$	—	ns	—
6	t_{SU}	Data setup time (inputs)	2	—	ns	—
7	t_{HI}	Data hold time (inputs)	7	—	ns	—
8	t_a	Slave access time	—	t_{periph}	ns	3
9	t_{dis}	Slave MISO disable time	—	t_{periph}	ns	4
10	t_v	Data valid (after SPSCK edge)	—	122	ns	—
11	t_{HO}	Data hold time (outputs)	0	—	ns	—
12	t_{RI}	Rise time input	—	$t_{periph} - 25$	ns	—
	t_{FI}	Fall time input				
13	t_{RO}	Rise time output	—	36	ns	—
	t_{FO}	Fall time output				

1. For SPI0, f_{periph} is the bus clock (f_{BUS}).
2. $t_{periph} = 1/f_{periph}$
3. Time to data active from high-impedance state
4. Hold time to high-impedance state

Peripheral operating requirements and behaviors

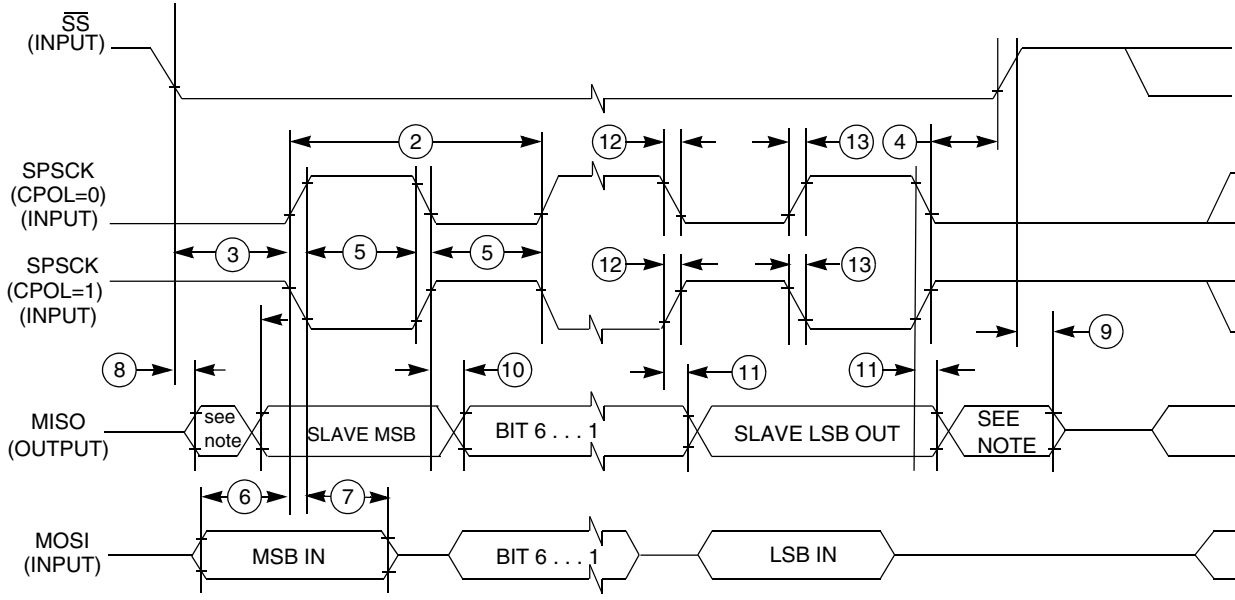

NOTE: Not defined

Figure 12. SPI slave mode timing (CPHA = 0)

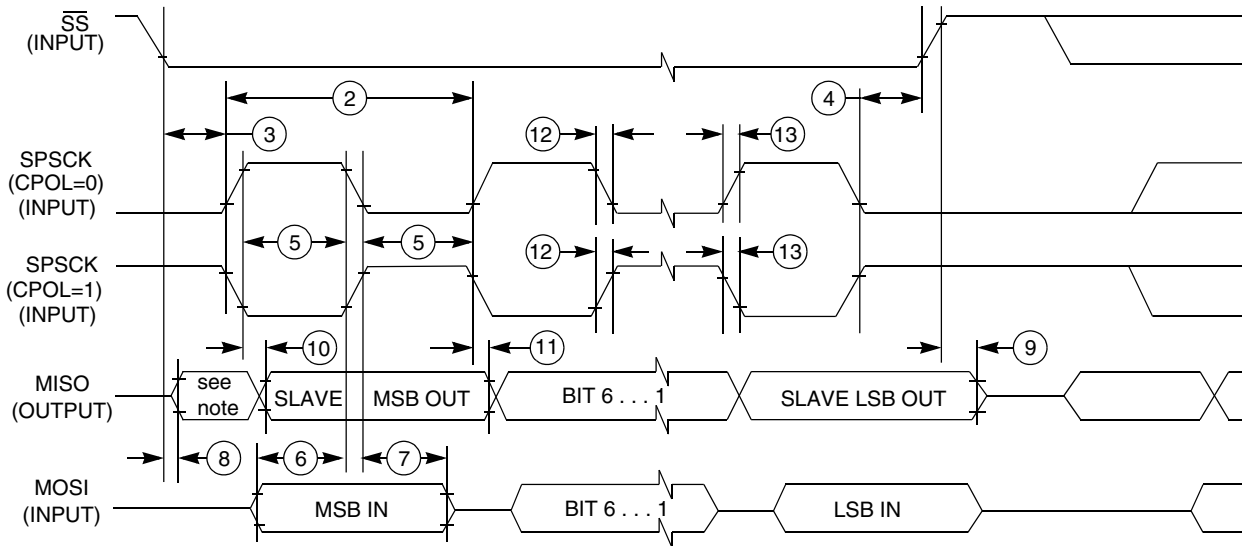

NOTE: Not defined

Figure 13. SPI slave mode timing (CPHA = 1)

3.8.2 Inter-Integrated Circuit Interface (I2C) timing

Table 32. I2C timing

Characteristic	Symbol	Standard Mode		Fast Mode		Unit
		Minimum	Maximum	Minimum	Maximum	
SCL Clock Frequency	f_{SCL}	0	100	0	400 ¹	kHz
Hold time (repeated) START condition. After this period, the first clock pulse is generated.	$t_{HD}; STA$	4	—	0.6	—	μs
LOW period of the SCL clock	t_{LOW}	4.7	—	1.3	—	μs
HIGH period of the SCL clock	t_{HIGH}	4	—	0.6	—	μs
Set-up time for a repeated START condition	$t_{SU}; STA$	4.7	—	0.6	—	μs
Data hold time for I ² C bus devices	$t_{HD}; DAT$	0 ²	3.45 ³	0 ⁴	0.9 ²	μs
Data set-up time	$t_{SU}; DAT$	250 ⁵	—	100 ^{3, 6}	—	ns
Rise time of SDA and SCL signals	t_r	—	1000	$20 + 0.1C_b$ ⁷	300	ns
Fall time of SDA and SCL signals	t_f	—	300	$20 + 0.1C_b$ ⁶	300	ns
Set-up time for STOP condition	$t_{SU}; STO$	4	—	0.6	—	μs
Bus free time between STOP and START condition	t_{BUF}	4.7	—	1.3	—	μs
Pulse width of spikes that must be suppressed by the input filter	t_{SP}	N/A	N/A	0	50	ns

1. The maximum SCL Clock Frequency in Fast mode with maximum bus loading can only be achieved when using the High drive pins (see [Voltage and current operating behaviors](#)) or when using the Normal drive pins and $V_{DD} \geq 2.7 V$
2. The master mode I²C deasserts ACK of an address byte simultaneously with the falling edge of SCL. If no slaves acknowledge this address byte, then a negative hold time can result, depending on the edge rates of the SDA and SCL lines.
3. The maximum $t_{HD}; DAT$ must be met only if the device does not stretch the LOW period (t_{LOW}) of the SCL signal.
4. Input signal Slew = 10 ns and Output Load = 50 pF
5. Set-up time in slave-transmitter mode is 1 IPBus clock period, if the TX FIFO is empty.
6. A Fast mode I²C bus device can be used in a Standard mode I²C bus system, but the requirement $t_{SU}; DAT \geq 250 ns$ must then be met. This is automatically the case if the device does not stretch the LOW period of the SCL signal. If such a device does stretch the LOW period of the SCL signal, then it must output the next data bit to the SDA line $t_{rmax} + t_{SU}; DAT = 1000 + 250 = 1250 ns$ (according to the Standard mode I²C bus specification) before the SCL line is released.
7. C_b = total capacitance of the one bus line in pF.

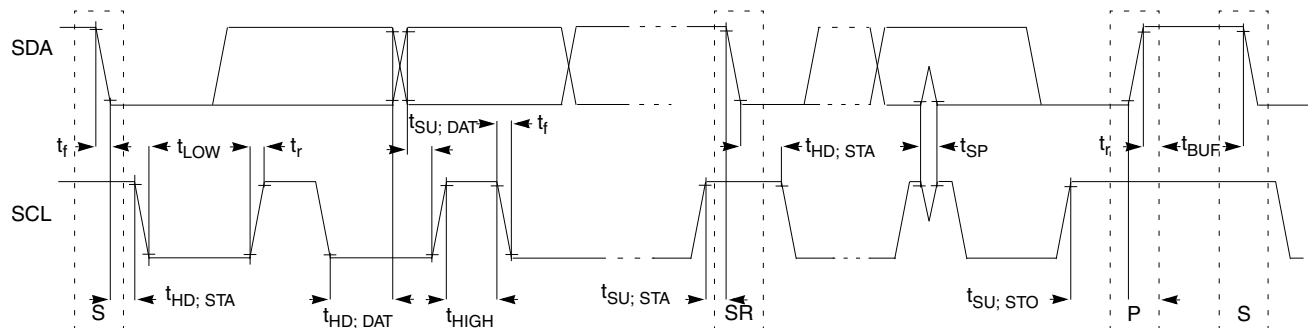

Figure 14. Timing definition for fast and standard mode devices on the I²C bus

3.8.3 UART

See [General switching specifications](#).

4 Dimensions

4.1 Obtaining package dimensions

Package dimensions are provided in package drawings.

To find a package drawing, go to freescale.com and perform a keyword search for the drawing's document number:

If you want the drawing for this package	Then use this document number
16-pin QFN	98ASA00525D
24-pin QFN	98ASA00474D
32-pin QFN	98ASA00473D

5 Pinout

5.1 KL02 signal multiplexing and pin assignments

The following table shows the signals available on each pin and the locations of these pins on the devices supported by this document. The Port Control Module is responsible for selecting which ALT functionality is available on each pin.

NOTE

PTB3 and PTB4 are true open drain pins. The external pullup resistor must be added to make them output correct values in using I2C, GPIO, and UART0.

32 QFN	24 QFN	16 QFN	Pin Name	Default	ALT0	ALT1	ALT2	ALT3
1	1	—	PTB6/ IRQ_2/ LPTMRO_ALT3	DISABLED		PTB6/ IRQ_2/ LPTMRO_ALT3	TPM1_CH1	TPM_CLKIN1

32 QFN	24 QFN	16 QFN	Pin Name	Default	ALT0	ALT1	ALT2	ALT3
2	2	—	PTB7/ IRQ_3	DISABLED		PTB7/ IRQ_3	TPM1_CH0	
3	3	1	VDD	VDD	VDD			
4	3	1	VREFH	VREFH	VREFH			
5	4	2	VREFL	VREFL	VREFL			
6	4	2	VSS	VSS	VSS			
7	5	3	PTA3	EXTAL0	EXTAL0	PTA3	I2C0_SCL	I2C1_SDA
8	6	4	PTA4	XTAL0	XTAL0	PTA4	I2C0_SDA	I2C1_SCL
9	7	5	PTA5	DISABLED		PTA5	TPM0_CH1	SPI0_SS_b
10	8	6	PTA6	DISABLED		PTA6	TPM0_CH0	SPI0_MISO
11	—	—	PTB8	ADC0_SE11	ADC0_SE11	PTB8		
12	—	—	PTB9	ADC0_SE10	ADC0_SE10	PTB9		
13	9	—	PTB10	ADC0_SE9	ADC0_SE9	PTB10	TPM0_CH1	
14	10	—	PTB11	ADC0_SE8	ADC0_SE8	PTB11	TPM0_CH0	
15	11	7	PTA7/ IRQ_4	ADC0_SE7	ADC0_SE7	PTA7/ IRQ_4	SPI0_MISO	SPI0_MOSI
16	12	8	PTB0/ IRQ_5	ADC0_SE6	ADC0_SE6	PTB0/ IRQ_5	EXTRG_IN	SPI0_SCK
17	13	9	PTB1/ IRQ_6	ADC0_SE5/ CMP0_IN3	ADC0_SE5/ CMP0_IN3	PTB1/ IRQ_6	UART0_TX	UART0_RX
18	14	10	PTB2/ IRQ_7	ADC0_SE4	ADC0_SE4	PTB2/ IRQ_7	UART0_RX	UART0_TX
19	15	—	PTA8	ADC0_SE3	ADC0_SE3	PTA8	I2C1_SCL	
20	16	—	PTA9	ADC0_SE2	ADC0_SE2	PTA9	I2C1_SDA	
21	—	—	PTA10/ IRQ_8	DISABLED		PTA10/ IRQ_8		
22	—	—	PTA11/ IRQ_9	DISABLED		PTA11/ IRQ_9		
23	17	11	PTB3/ IRQ_10	DISABLED		PTB3/ IRQ_10	I2C0_SCL	UART0_TX
24	18	12	PTB4/ IRQ_11	DISABLED		PTB4/ IRQ_11	I2C0_SDA	UART0_RX
25	19	13	PTB5/ IRQ_12	NMI_b	ADC0_SE1/ CMP0_IN1	PTB5/ IRQ_12	TPM1_CH1	NMI_b
26	20	—	PTA12/ IRQ_13/ LPTMR0_ALT2	ADC0_SE0/ CMP0_IN0	ADC0_SE0/ CMP0_IN0	PTA12/ IRQ_13/ LPTMR0_ALT2	TPM1_CH0	TPM_CLKIN0
27	—	—	PTA13	DISABLED		PTA13		
28	—	—	PTB12	DISABLED		PTB12		
29	21	—	PTB13	ADC0_SE13	ADC0_SE13	PTB13	TPM1_CH1	
30	22	14	PTA0/ IRQ_0	SWD_CLK	ADC0_SE12/ CMP0_IN2	PTA0/ IRQ_0	TPM1_CH0	SWD_CLK

Pinout

32 QFN	24 QFN	16 QFN	Pin Name	Default	ALT0	ALT1	ALT2	ALT3
31	23	15	PTA1/ IRQ_1/ LPTMR0_ALT1	RESET_b		PTA1/ IRQ_1/ LPTMR0_ALT1	TPM_CLKIN0	RESET_b
32	24	16	PTA2	SWD_DIO		PTA2	CMPO_OUT	SWD_DIO

5.2 KL02 pinouts

The following figures show the pinout diagrams for the devices supported by this document. Many signals may be multiplexed onto a single pin. To determine what signals can be used on which pin, see [KL02 signal multiplexing and pin assignments](#).

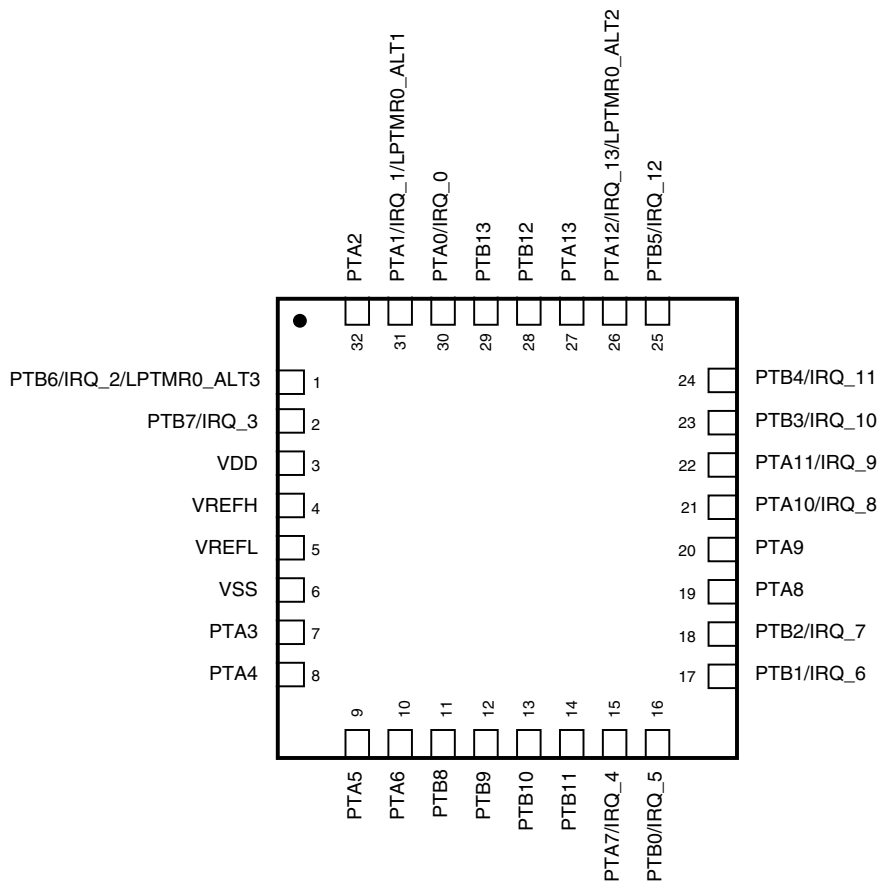

Figure 15. KL02 32-pin QFN pinout diagram

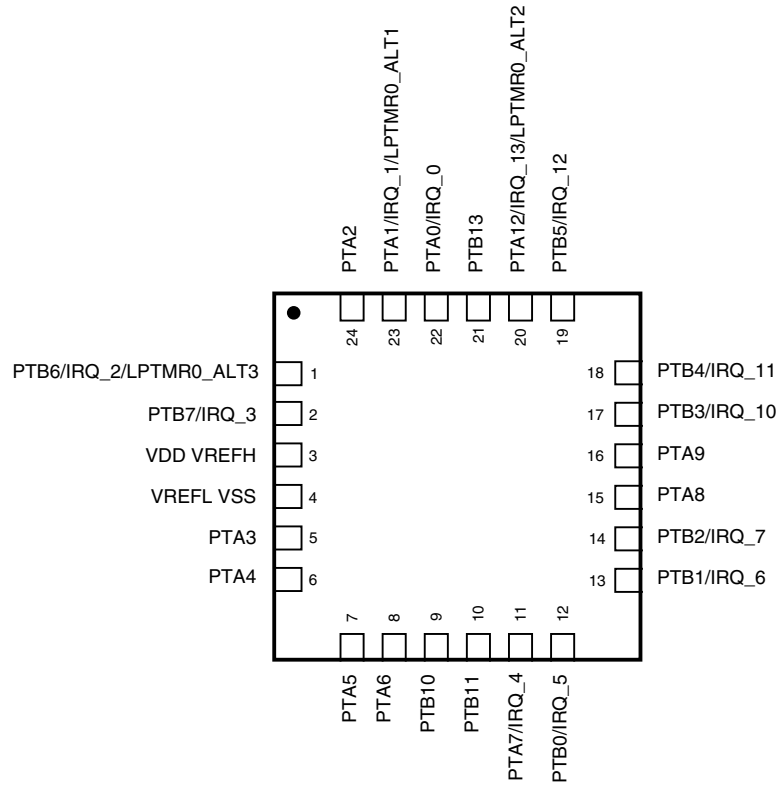

Figure 16. KL02 24-pin QFN pinout diagram

Ordering parts

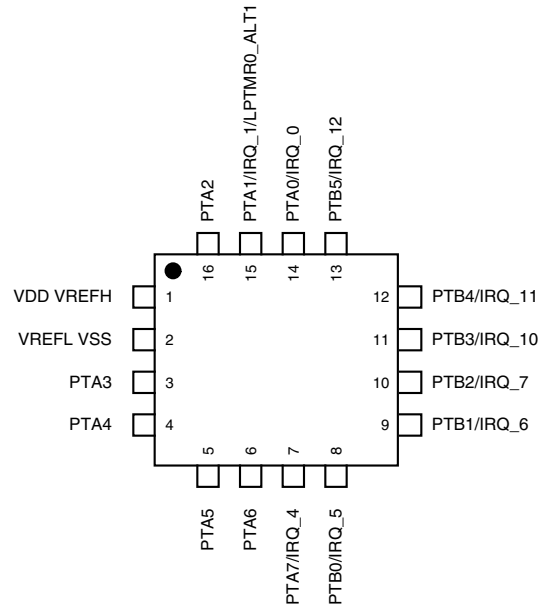

Figure 17. KL02 16-pin QFN pinout diagram

6 Ordering parts

6.1 Determining valid orderable parts

Valid orderable part numbers are provided on the web. To determine the orderable part numbers for this device, go to freescale.com and perform a part number search for the following device numbers: PKL02 and MKL02

7 Part identification

7.1 Description

Part numbers for the chip have fields that identify the specific part. You can use the values of these fields to determine the specific part you have received.

7.2 Format

Part numbers for this device have the following format:

Q KL## A FFF R T PP CC N

7.3 Fields

This table lists the possible values for each field in the part number (not all combinations are valid):

Table 33. Part number fields descriptions

Field	Description	Values
Q	Qualification status	<ul style="list-style-type: none"> M = Fully qualified, general market flow P = Prequalification
KL##	Kinetis family	<ul style="list-style-type: none"> KL02
A	Key attribute	<ul style="list-style-type: none"> Z = Cortex-M0+
FFF	Program flash memory size	<ul style="list-style-type: none"> 8 = 8 KB 16 = 16 KB 32 = 32 KB
R	Silicon revision	<ul style="list-style-type: none"> (Blank) = Main A = Revision after main
T	Temperature range (°C)	<ul style="list-style-type: none"> V = -40 to 105
PP	Package identifier	<ul style="list-style-type: none"> FG = 16 QFN (3 mm x 3 mm) FK = 24 QFN (4 mm x 4 mm) FM = 32 QFN (5 mm x 5 mm)
CC	Maximum CPU frequency (MHz)	<ul style="list-style-type: none"> 4 = 48 MHz
N	Packaging type	<ul style="list-style-type: none"> R = Tape and reel (Blank) = Trays

7.4 Example

This is an example part number:

MKL02Z8VFG4

8 Small package marking

In order to save space, small package devices use special marking on the chip.

Q FS FF (TP)

Table 34. Small package marking

Field	Description	Values
Q	Qualification status	<ul style="list-style-type: none"> • M = M • P = P
FS	Kinetis family and CPU frequency	<ul style="list-style-type: none"> • (0)2T = KL02, 48 MHz of CPU
FF	Program flash memory size	<ul style="list-style-type: none"> • 3 = 8 KB • 4 = 16 KB • 5 = 32 KB
TP	Temperature range (°C) and package	<ul style="list-style-type: none"> • V = -40 to 105, 24 or 32 QFN • blank = -40 to 105, 16 QFN

For example:

M2T4 = MKL02Z16VFG4

M02T4V = MKL02Z16VFK4

9 Terminology and guidelines

9.1 Definition: Operating requirement

An *operating requirement* is a specified value or range of values for a technical characteristic that you must guarantee during operation to avoid incorrect operation and possibly decreasing the useful life of the chip.

9.1.1 Example

This is an example of an operating requirement:

Symbol	Description	Min.	Max.	Unit
V _{DD}	1.0 V core supply voltage	0.9	1.1	V

9.2 Definition: Operating behavior

An *operating behavior* is a specified value or range of values for a technical characteristic that are guaranteed during operation if you meet the operating requirements and any other specified conditions.

9.2.1 Example

This is an example of an operating behavior:

Symbol	Description	Min.	Max.	Unit
I _{WP}	Digital I/O weak pullup/pulldown current	10	130	μA

9.3 Definition: Attribute

An *attribute* is a specified value or range of values for a technical characteristic that are guaranteed, regardless of whether you meet the operating requirements.

9.3.1 Example

This is an example of an attribute:

Symbol	Description	Min.	Max.	Unit
CIN_D	Input capacitance: digital pins	—	7	pF

9.4 Definition: Rating

A *rating* is a minimum or maximum value of a technical characteristic that, if exceeded, may cause permanent chip failure:

- *Operating ratings* apply during operation of the chip.
- *Handling ratings* apply when the chip is not powered.

9.4.1 Example

This is an example of an operating rating:

Symbol	Description	Min.	Max.	Unit
V _{DD}	1.0 V core supply voltage	-0.3	1.2	V

9.5 Result of exceeding a rating

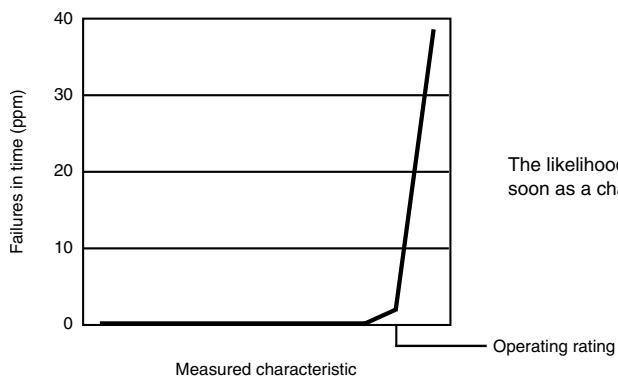

The likelihood of permanent chip failure increases rapidly as soon as a characteristic begins to exceed one of its operating ratings.

9.6 Relationship between ratings and operating requirements

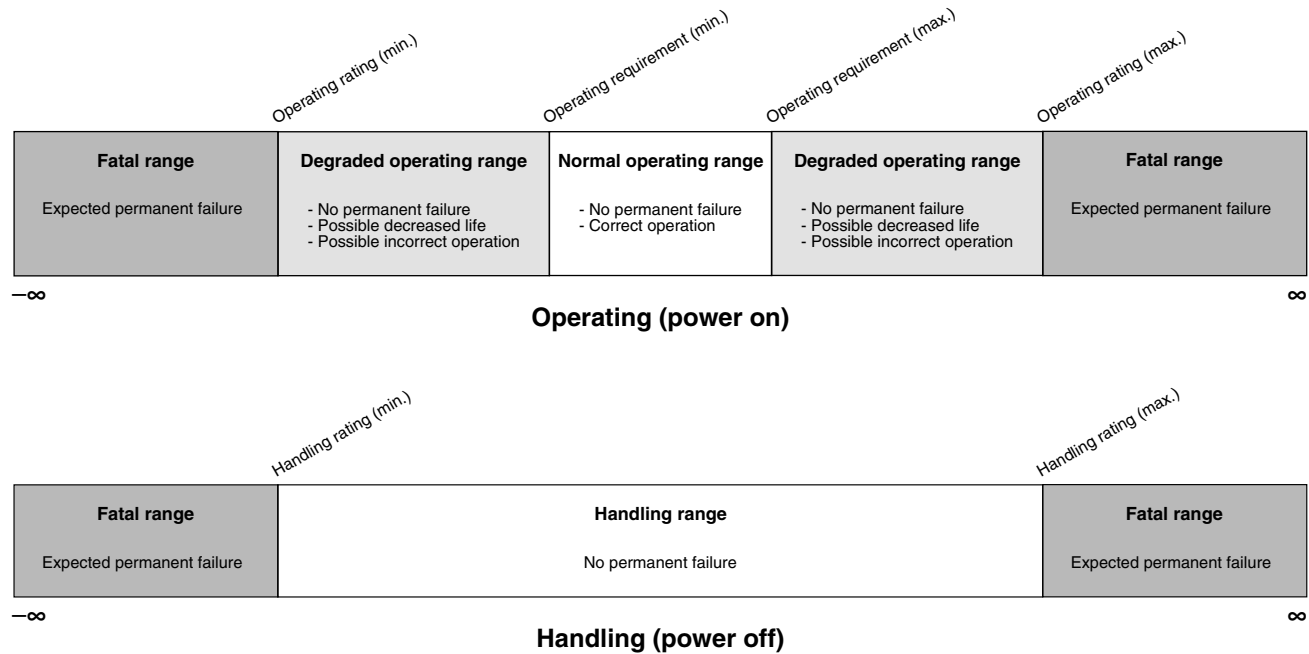

9.7 Guidelines for ratings and operating requirements

Follow these guidelines for ratings and operating requirements:

- Never exceed any of the chip's ratings.
- During normal operation, don't exceed any of the chip's operating requirements.
- If you must exceed an operating requirement at times other than during normal operation (for example, during power sequencing), limit the duration as much as possible.

9.8 Definition: Typical value

A *typical value* is a specified value for a technical characteristic that:

- Lies within the range of values specified by the operating behavior
- Given the typical manufacturing process, is representative of that characteristic during operation when you meet the typical-value conditions or other specified conditions

Typical values are provided as design guidelines and are neither tested nor guaranteed.

9.8.1 Example 1

This is an example of an operating behavior that includes a typical value:

Symbol	Description	Min.	Typ.	Max.	Unit
I_{WP}	Digital I/O weak pullup/pulldown current	10	70	130	μA

9.8.2 Example 2

This is an example of a chart that shows typical values for various voltage and temperature conditions:

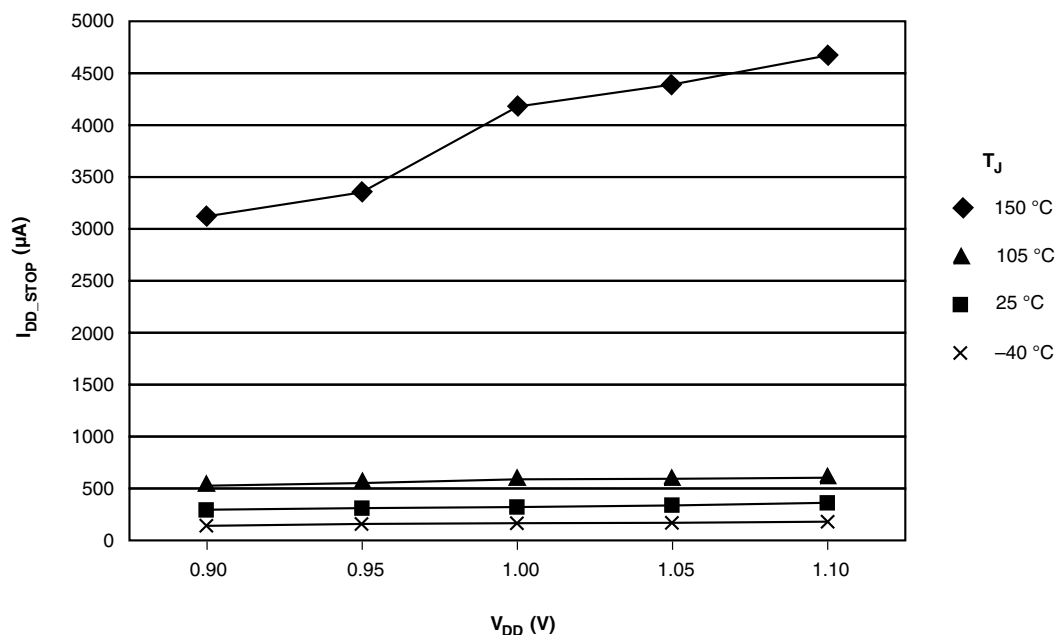

9.9 Typical value conditions

Typical values assume you meet the following conditions (or other conditions as specified):

Table 35. Typical value conditions

Symbol	Description	Value	Unit
T _A	Ambient temperature	25	°C
V _{DD}	3.3 V supply voltage	3.3	V

10 Revision history

The following table provides a revision history for this document.

Table 36. Revision history

Rev. No.	Date	Substantial Changes
2	05/2013	Public release.
2.1	07/2013	Removed the specification on OSCERCLK (4 MHz external crystal) because KL02 does not support it.
3	3/2014	<ul style="list-style-type: none"> • Updated the front page and restructured the chapters • Added a note to the I_{LAT} in the ESD handling ratings • Updated table title in the Voltage and current operating ratings • Updated Voltage and current operating requirements • Updated footnote to the V_{OH} in the Voltage and current operating behaviors • Updated Power mode transition operating behaviors • Updated Capacitance attributes • Updated the Device clock specifications • Added Inter-Integrated Circuit Interface (I2C) timing



How to Reach Us:

Home Page:

freescale.com

Web Support:

freescale.com/support

Information in this document is provided solely to enable system and software implementers to use Freescale products. There are no express or implied copyright licenses granted hereunder to design or fabricate any integrated circuits based on the information in this document. Freescale reserves the right to make changes without further notice to any products herein.

Freescale makes no warranty, representation, or guarantee regarding the suitability of its products for any particular purpose, nor does Freescale assume any liability arising out of the application or use of any product or circuit, and specifically disclaims any and all liability, including without limitation consequential or incidental damages. "Typical" parameters that may be provided in Freescale data sheets and/or specifications can and do vary in different applications, and actual performance may vary over time. All operating parameters, including "typicals," must be validated for each customer application by customer's technical experts. Freescale does not convey any license under its patent rights nor the rights of others. Freescale sells products pursuant to standard terms and conditions of sale, which can be found at the following address: freescale.com/SalesTermsandConditions.

Freescale, the Freescale logo, Energy Efficient Solutions logo, and Kinetis are trademarks of Freescale Semiconductor, Inc., Reg. U.S. Pat. & Tm. Off. All other product or service names are the property of their respective owners. ARM and Cortex-M0+ are the registered trademarks of ARM Limited.

© 2012-2014 Freescale Semiconductor, Inc.

Document Number KL02P32M48SF0
Revision 3 03/2014

