

ASSEMBLY

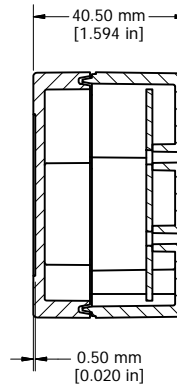

SECTION A-A

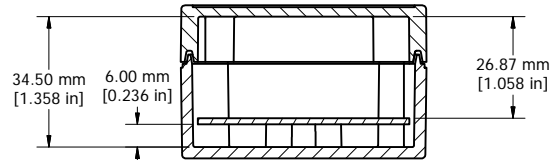
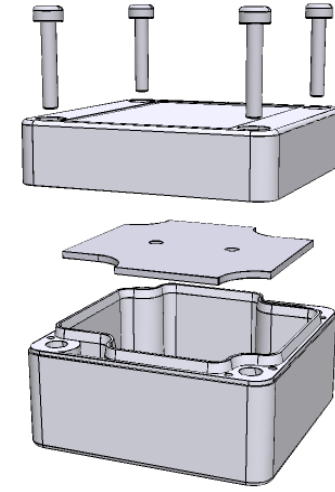

SECTION B-B

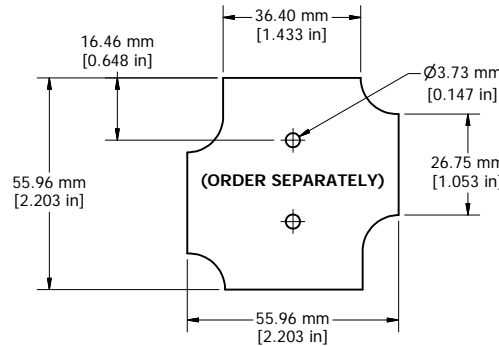

STEEL INNER PANEL

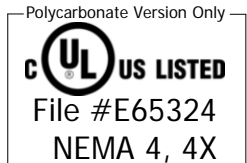

Enclosures can be Factory Modified ( Milling, Drilling, Printing etc. )  
 Solid models of this enclosure available in STEP or IGES.  
 Contact Factory [mjm@hammondmfg.com](mailto:mjm@hammondmfg.com)

NOTE	
Purchased assembly includes box, styled lid, 4 cover screws, and preformed silicone gasket.	
General Purpose ABS version is not UL approved. (Matl UL94 - HB)	
Polycarbonate version is UL 508 approved. (Matl UL94 - V0)	
<b>Recommended Cover screw torque -- 2.5 lbf-in (30 cN-m)</b>	

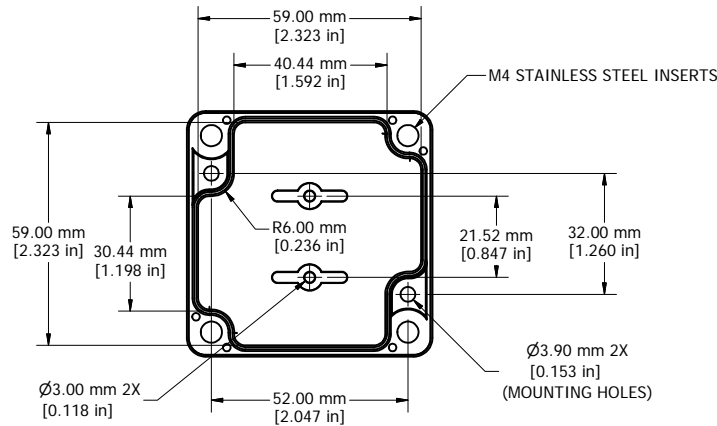

BOX - INSIDE

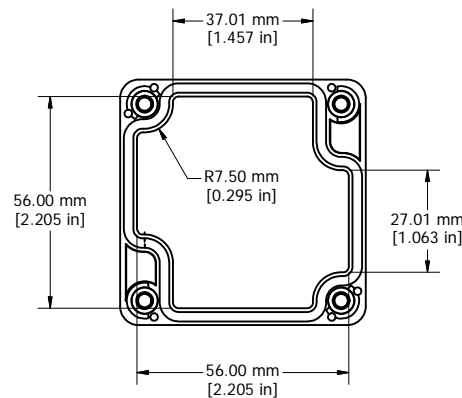

LID - INSIDE

1555B	
1555B Regular Enclosure	
General Purpose ABS RAL-7035	1555BGY
Polycarbonate RAL-7035	1555B2GY
ACCESSORIES	
Steel Inner Panels	1554BPL
Steel Panel / P.C. Board Machine Screw [M3 x 8mm Plated]	1591MM100
Steel Panel / P.C. Board Self Tapping Screw [#6 X 1/4" (6.4mm) Plated]	1598ATS100
Cover Screws (Pkg 4) [M4 X 20mm Stainless Steel]	SC1554

