

## Features

- Formerly a JENSEN DEVICES product
- Fast switching rate
- High energy, low loss capability
- Wide operating temperature range
- Long service life
- High insulation resistance
- RoHS compliant\*

## Applications

- Igniters for architectural and automotive Xenon discharge lamps
- Electronic igniters for gas heating and gas domestic appliances, e.g., cookers
- Ignition of ultra-high pressure gas discharge lamps for data and video projectors

## Sparctube™ Switching Spark Gap ST-0470 Series

### Description

Bourns® Sparctube™ Switching Spark Gap Series is a range of switching spark gaps designed specifically for voltage controlled switching of capacitive discharge circuits where a high energy, low loss, fast rate of switching is required. This series is ideally suited for applications where a capacitive discharge is utilized with a transformer to obtain pulses of very high voltage levels in the order of several thousand volts.

### Characteristics

#### Initial Values:

Static Breakdown Voltage @ 800 V/s <sup>1</sup>

First Ignition Values .....	< 620 V
Following Ignition Values .....	470 V ±12 %

#### Electrical Life:

Minimum Number of Switching Cycles .....	2x10 <sup>5</sup>
Peak Current (Approx.) .....	500 A
Maximum Switching Frequency .....	200 Hz
Breakdown Characteristics @ 620 V Limit	
First Ignition Values .....	≤ 620 V
Delay Time .....	< 60 ms
Following Ignition Values .....	470 V ±15 %

#### General Data:

Breakdown Time .....	< 50 ns
Insulation Resistance @100 Vdc .....	> 100 megohms
Share of Early Ignition Values (< 400 V) .....	< 1 %
Capacitance .....	< 1 pF
Operating Temperature Range <sup>2</sup> .....	-40 °C to +160 °C
Storage Temperature Range .....	-65 °C to +125 °C
Weight (Approx.) .....	2.3 g
Testing .....	100 %
Robustness of Terminations .....	IEC 60068-2-21 <sup>3</sup>

#### Notes:

- <sup>1</sup> At delivery AQL 0.65 Level II, DIN ISO 2859.
- <sup>2</sup> Distribution of switchings: maximum 20 % above +125 °C and 20 % below +20°C.
- <sup>3</sup> Test Ua1 (tensile), Ua2 (thrust), Ub (bending) and Uc (torsion).

### Basic Application Circuit

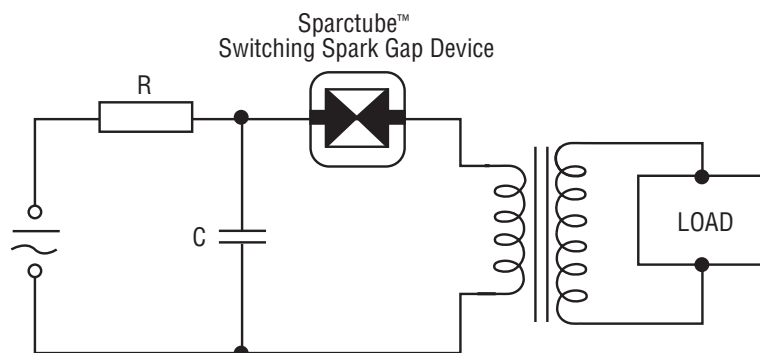

**BOURNS®**

#### Asia-Pacific:

Tel: +886-2 2562-4117  
Fax: +886-2 2562-4116

#### EMEA:

Tel: +36 88 520 390  
Fax: +36 88 520 211

#### The Americas:

Tel: +1-951 781-5500  
Fax: +1-951 781-5700

[www.bourns.com](http://www.bourns.com)

\*RoHS Directive 2002/95/EC Jan. 27, 2003 including annex and RoHS Recast 2011/65/EU June 8, 2011.

Specifications are subject to change without notice.

The device characteristics and parameters in this data sheet can and do vary in different applications and actual device performance may vary over time. Users should verify actual device performance in their specific applications.

# Sparctube™ Switching Spark Gap ST-0470 Series

**BOURNS®**

## Product Dimensions

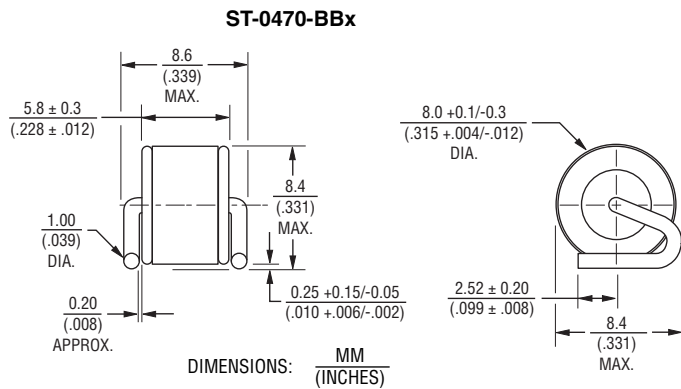
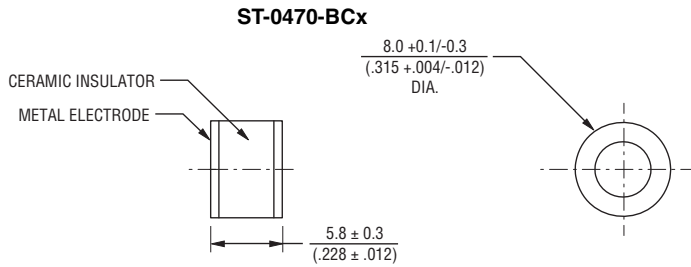
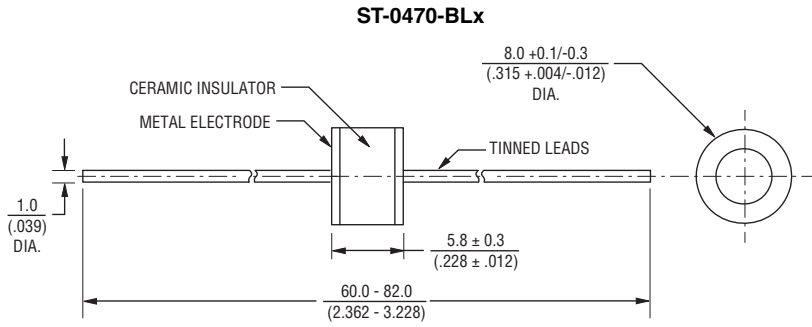

## How to Order

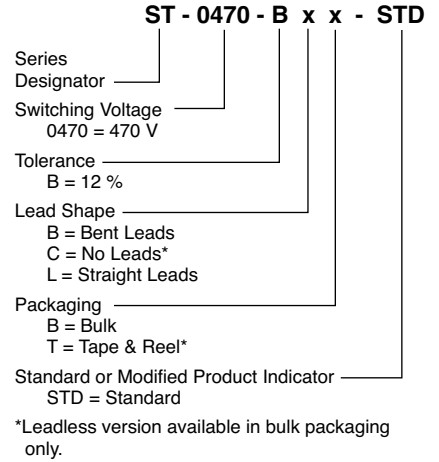

## Typical Part Marking

**B** ST 0470 wwy ..... "wwy" = Week and year of production

## Test Circuit

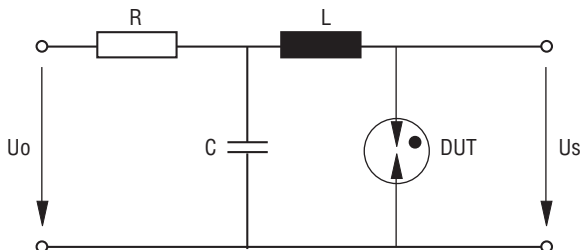

$U_o$  ..... 620 V  
 R ..... See Note  
 C ..... 470 nF  
 L ..... 0.5  $\mu$ H  
 DUT ..... Device Under Test  
 $U_s$  ..... Breakdown Voltages

NOTE:  $U_o$  and R are set to provide suitable conditions for different measurements.

Specifications are subject to change without notice. The device characteristics and parameters in this data sheet can and do vary in different applications and actual device performance may vary over time. Users should verify actual device performance in their specific applications.

# Sparctube™ Switching Spark Gap ST-0470 Series

**BOURNS®**

## Packaging Specifications

Models ST-0470-BBB, ST-0470-BLB and ST-0470-BCB\* ship standard bulk pack, 1,000 pcs./bag. The optional tape and reel packaging contains 1,000 pcs./reel for Model ST-0470-BLT; 500 pcs./reel for Model ST-0470-BBT.

\* Available in bulk packaging only.

**ST-0470-BLT**

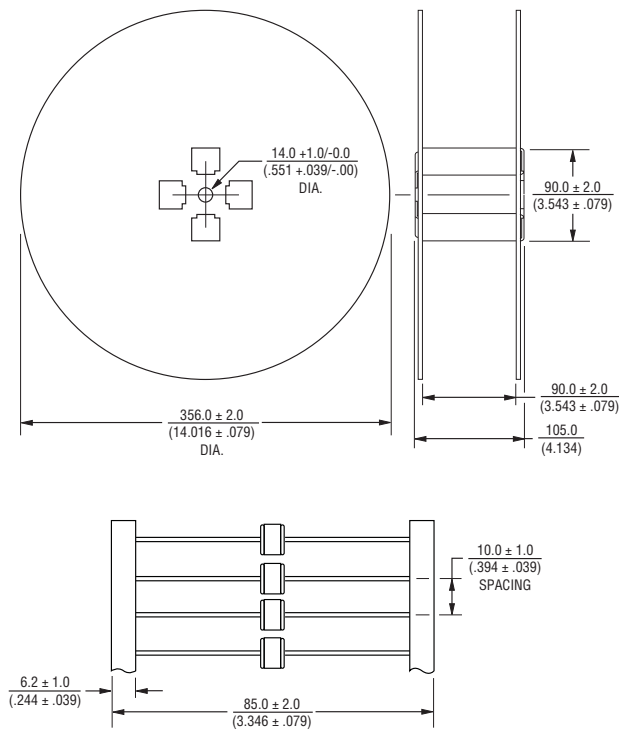

**ST-0470-BBT**

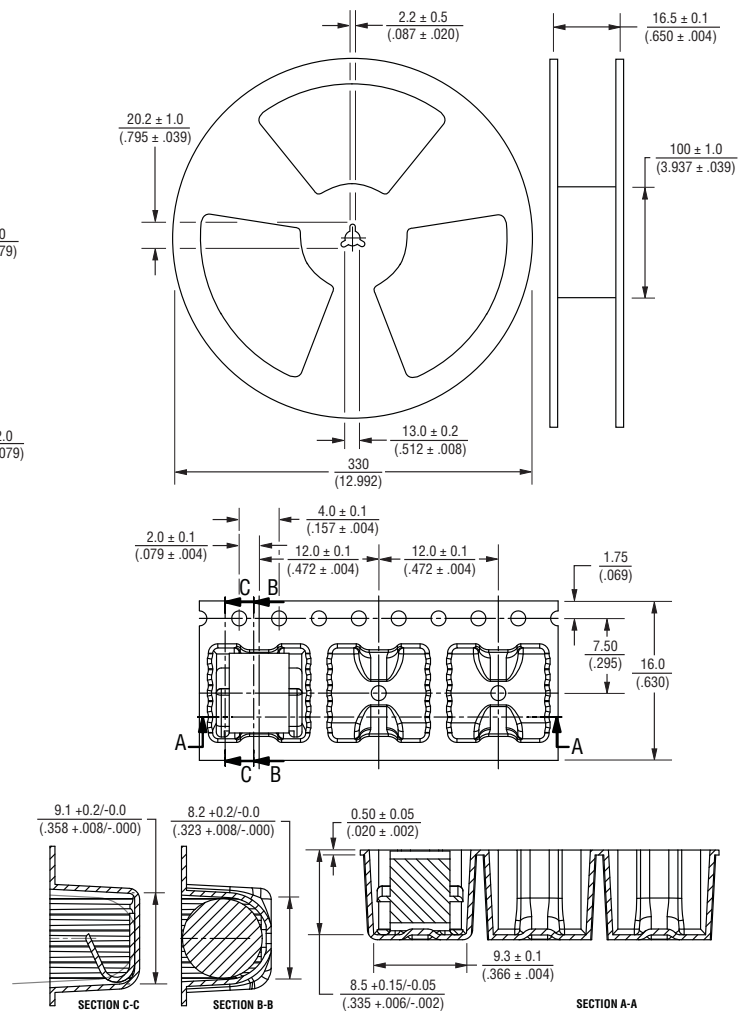

DIMENSIONS:  $\frac{\text{MM}}{\text{(INCHES)}}$

REV. 04/17/14

"Sparctube" is a registered trademark of Bourns, Inc. in China and the European Community, with a trademark registration application pending in the U.S. Specifications are subject to change without notice. The device characteristics and parameters in this data sheet can and do vary in different applications and actual device performance may vary over time. Users should verify actual device performance in their specific applications.