



PART NAME

PIP SERIES - PC 10% FIBERGLASS BOX

PART No.

PIP-11766

PIP-11766-C

REVISION DATE

3-28-14

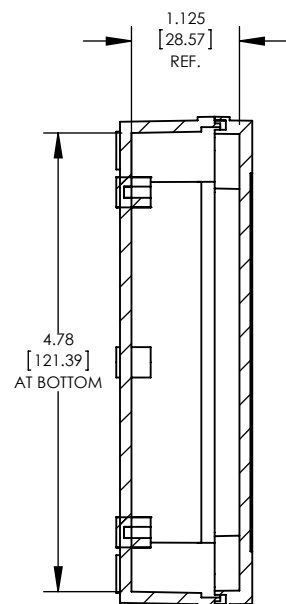

SECTION B-B

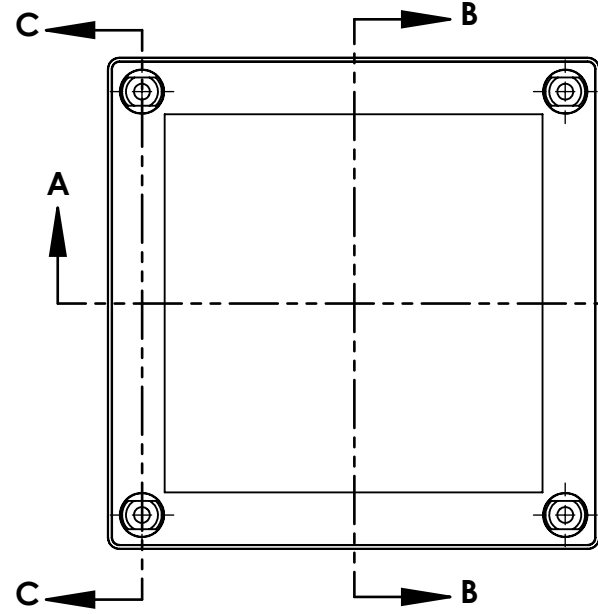

SECTION A-A

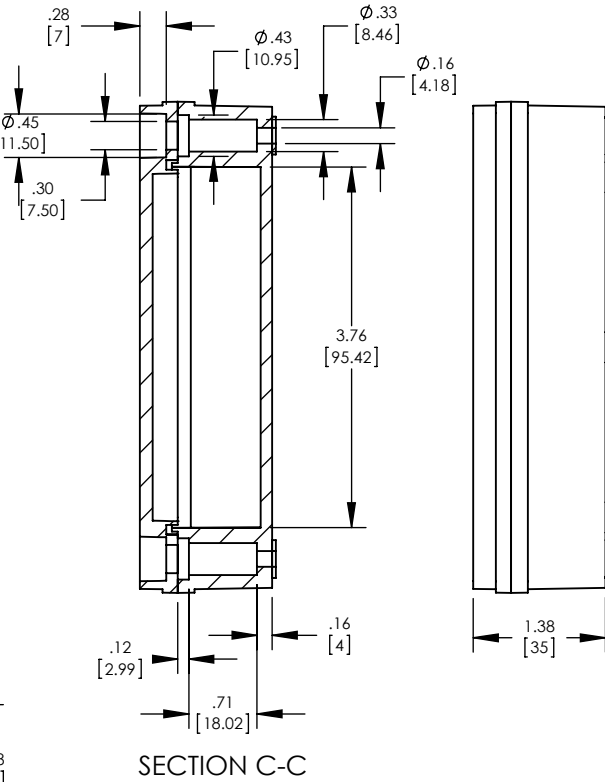
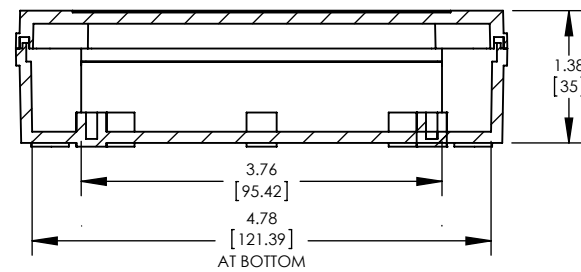

SECTION C-C

ASSEMBLY

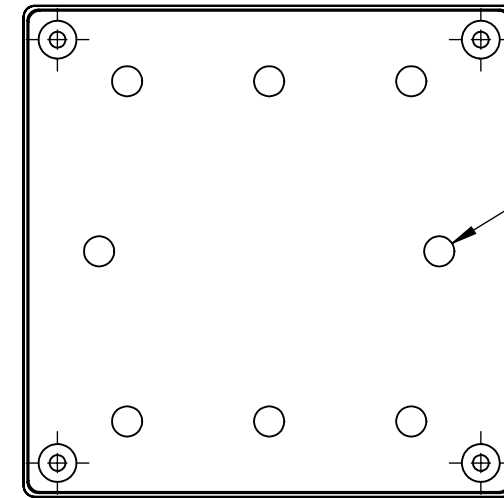

Ø.32 [8]

- NOTES:
- 1- MATERIAL: BODY AND COVER - POLYCARBONATE  
10% FIBERGLASS REINFORCED
  - 2- FINISH: BODY - LIGHT GRAY  
COVER - LIGHT GRAY/CLEAR
  - 3- ALL HOLE DIAMETERS HAVE +/- .005 [.13] TOLERANCE  
ALL OTHER DIMENSIONS HAVE +/- .03 [.76] TOLERANCE  
UNLESS OTHERWISE SPECIFIED
  - 4- SUPPLIED WITH NON-METALLIC CAPTIVE SCREWS
  - 5- FOUR M4 THREAD FORMING SCREWS SUPPLIED
  - 6- DIMENSIONS ARE INCH [MM]

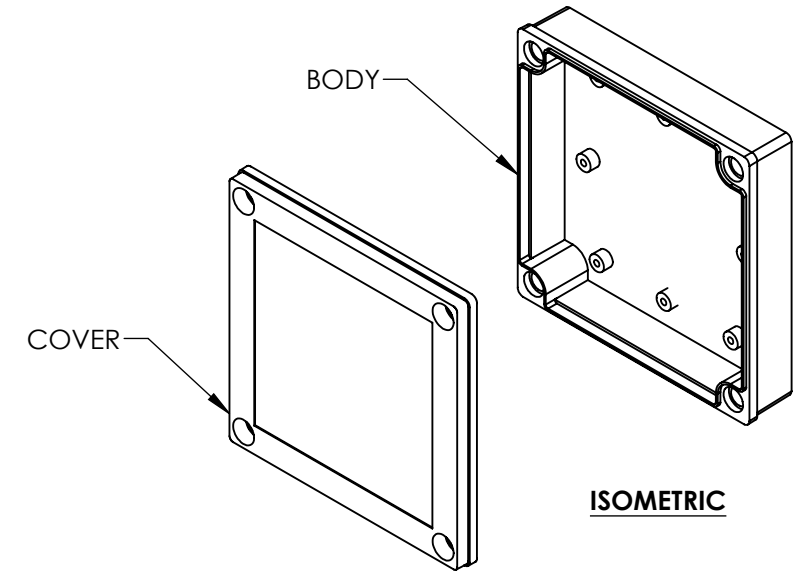

ISOMETRIC

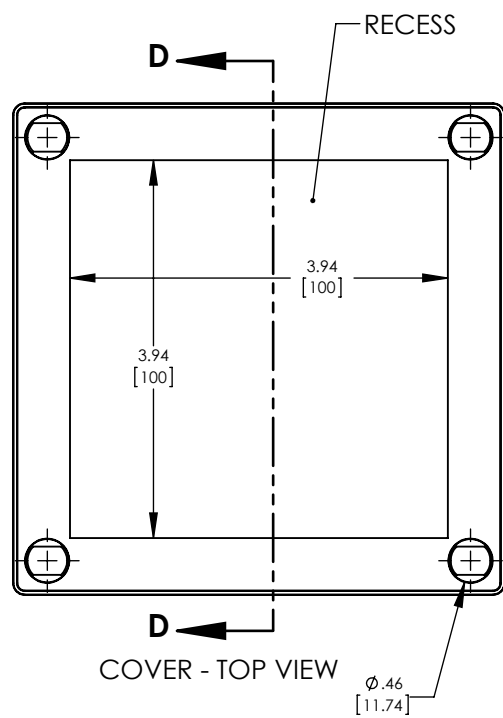

COVER - TOP VIEW

Ø.46 [11.74]

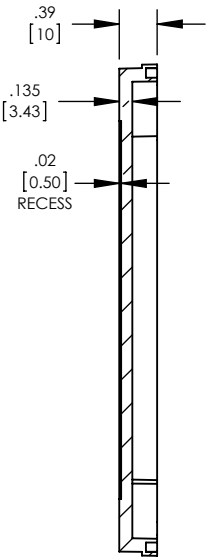

SECTION D-D

COVER

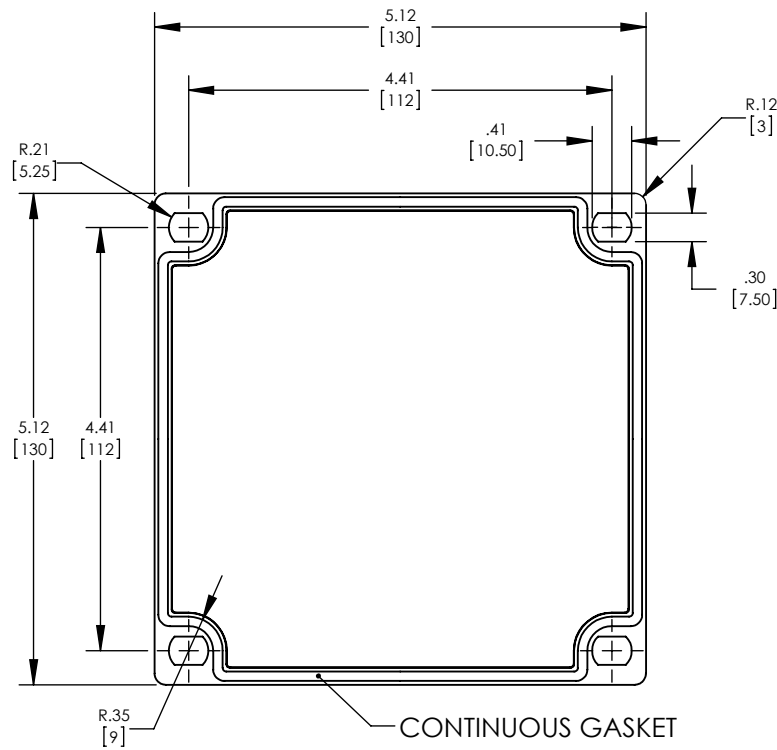

COVER - BACK VIEW

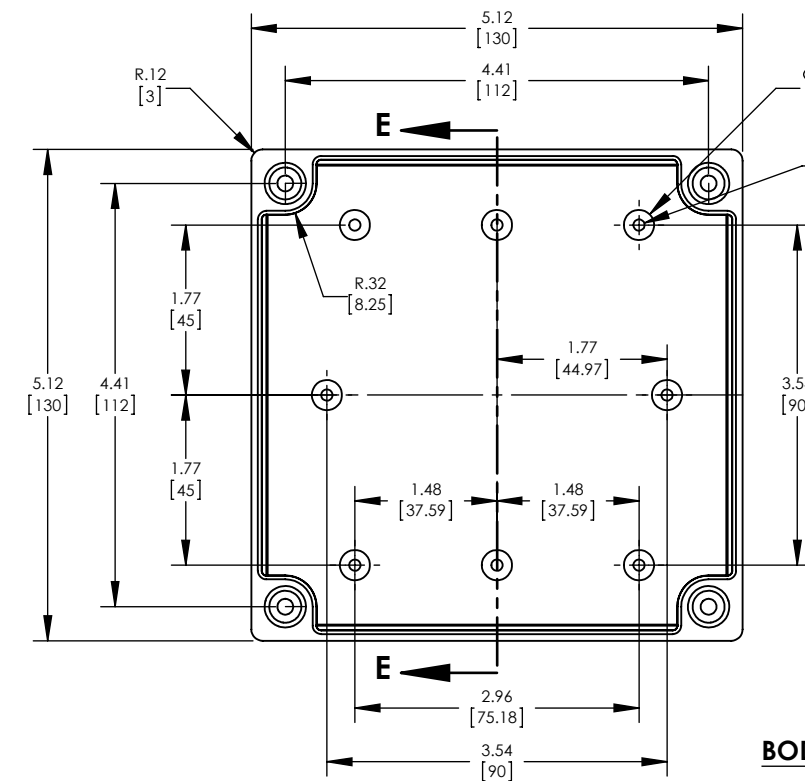

BODY

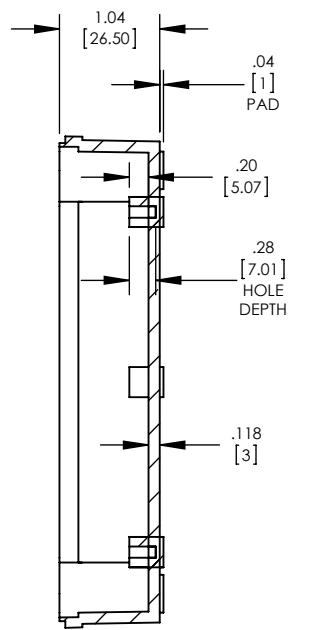

SECTION E-E