



PART NAME

PIP SERIES - PC 10% FIBERGLASS BOX

PART No.

PIP-11777

PIP-11777-C

REVISION DATE

3-28-14

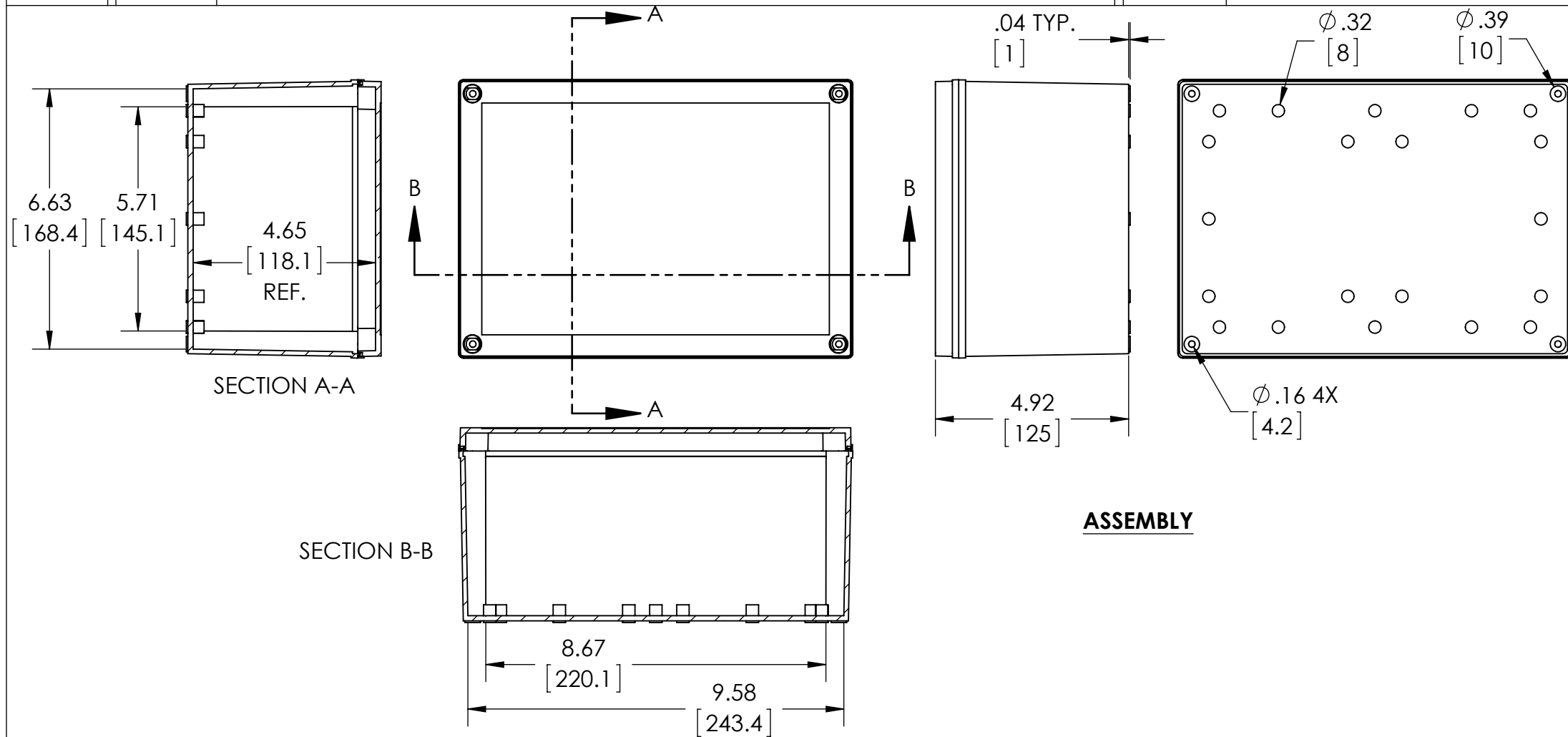

- NOTES:
- 1- MATERIAL: BODY AND COVER - POLYCARBONATE 10% FIBERGLASS REINFORCED
  - 2- FINISH: BODY - LIGHT GRAY COVER - LIGHT GRAY/CLEAR
  - 3- ALL HOLE DIAMETERS HAVE +/- .005[0.13] TOLERANCE ALL OTHER DIMENSIONS HAVE +/- .03[0.76] TOLERANCE UNLESS OTHERWISE SPECIFIED
  - 4- SUPPLIED WITH NON-METALLIC CAPTIVE SCREWS
  - 5- FOUR M4 THREAD FORMING SCREWS SUPPLIED
  - 6- DIMENSIONS ARE INCH[MM]

