

# D2D

Power/Door Switch

## Door Interlock Power Switch with Minimum Contact gap of 3 mm

- Offers the minimum contact gap of 3 mm required for power switches as standard equipment.
- Safety considerations include a double return spring and direct drive positive contact opening feature.
- Pull-on lock model for easy maintenance is also available.

RoHS Compliant

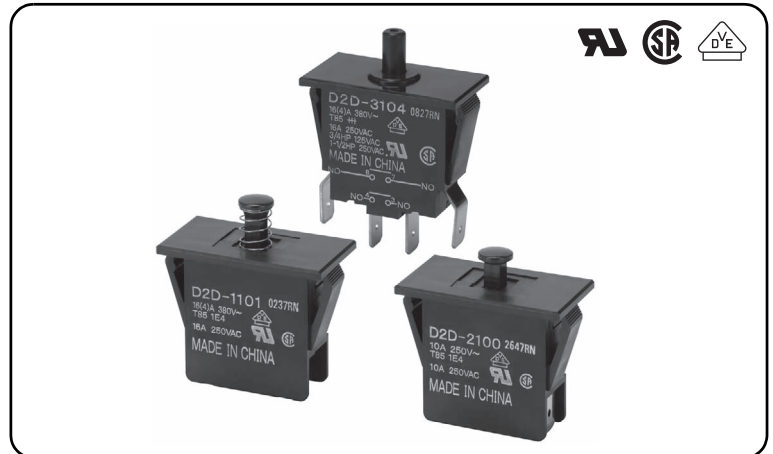

### Model Number Legend

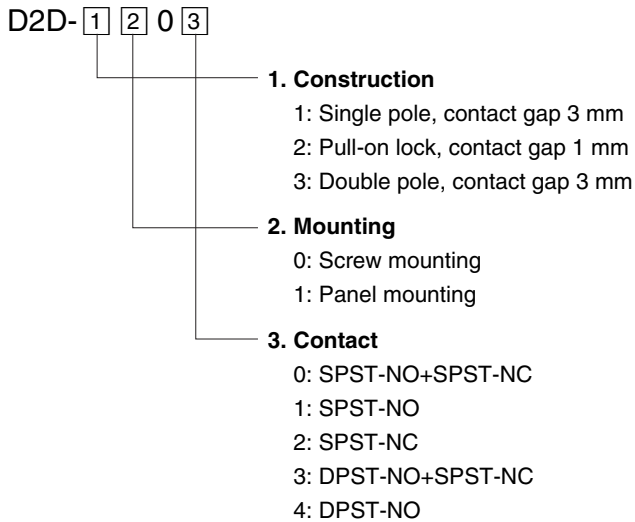

### List of Models

Mounting	Type Contact gap Contact form	Standard	Pull-on lock *
		3 mm min.	1 mm
Screw mounting	SPST-NO+SPST-NC	<b>D2D-1000</b>	<b>D2D-2000</b>
	SPST-NO	<b>D2D-1001</b>	-
	SPST-NC	<b>D2D-1002</b>	-
Panel mounting	SPST-NO+SPST-NC	<b>D2D-1100</b>	<b>D2D-2100</b>
	SPST-NO	<b>D2D-1101</b>	-
	SPST-NC	<b>D2D-1102</b>	-
	DPST-NO+SPST-NC	<b>D2D-3103</b>	-
	DPST-NO	<b>D2D-3104</b>	-

\* Refer to **next page** for the pull-on lock function.

### Contact Form

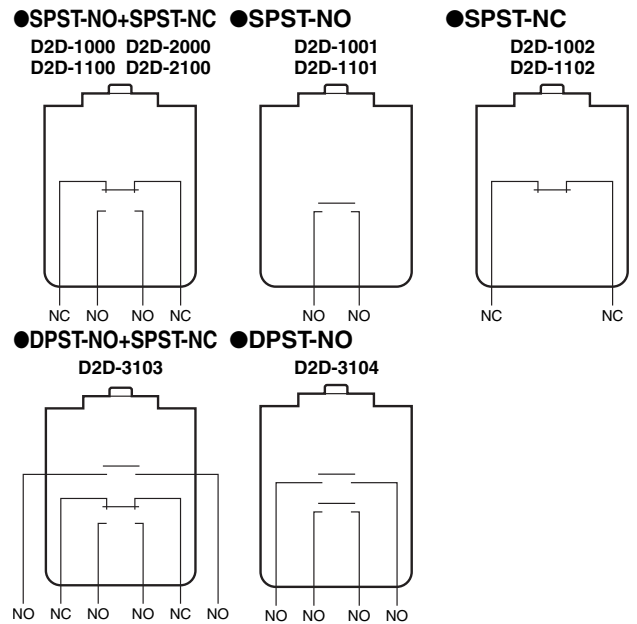

### Contact Specifications

Item	Type	Standard	Pull-on lock
Contact	Specification	Rivet	
	Material	Silver	
	Gap (standard value)	3 mm min.	1 mm
Inrush current	NC	30 A max.	24 A max.
	NO	30 A max.	24 A max.
Minimum applicable load (reference value) *		5 VDC 160mA	

\* Please refer to "●Using Micro Loads" in "■Precautions" for more information on the minimum applicable load.

### Ratings

Type	Item Rated voltage	Resistive load
Standard	250 VAC	16 A
Pull-on lock model	250 VAC	10 A

Note. The above rating values apply under the following test conditions.

- (1) Ambient temperature: 20±2°C
- (2) Ambient humidity: 65±5%
- (3) Operating frequency: 30 operations/min

Terminal Connection Parts (Sold Separately) ➔ Refer to "Basic Switch Common Accessories"

D2D

## Characteristics

Item	Model	D2D-1000 models	D2D-2000 models	D2D-3000 models
Permissible operating speed		10 mm to 1 m/s		
Permissible operating frequency	Mechanical	300 operations/min		
	Electrical	60 operations/min		
Insulation resistance		100 MΩ min. (at 500 VDC with insulation tester)		
Contact resistance (initial value)		50 mΩ max.		
Dielectric strength	Between terminals of the same polarity	2,000 VAC 50/60 Hz 1min	1,000 VAC 50/60 Hz 1min	2,000 VAC 50/60 Hz 1min
	Between current-carrying metal parts and ground	2,000 VAC 50/60 Hz 1min	1,500 VAC 50/60 Hz 1min	2,000 VAC 50/60 Hz 1min
	Between each terminal and non-current-carrying metal parts	2,500 VAC 50/60 Hz 1min	1,500 VAC 50/60 Hz 1min	-
	Between terminals and actuator	4,000 VAC 50/60 Hz 1min	-	4,000 VAC 50/60 Hz 1min
Vibration resistance	Malfunction	10 to 55 Hz, 1.5 mm double amplitude		
Shock resistance	Durability	1,000 m/s <sup>2</sup> {approx. 100G} max.		
	Malfunction	500 m/s <sup>2</sup> {approx. 50G} max.	300 m/s <sup>2</sup> {approx. 30G} max.	500 m/s <sup>2</sup> {approx. 50G} max.
Durability *	Mechanical	10,000,000 operations min. (60 operations/min)		
	Electrical	100,000 operations min. (30 operations/min)		
Degree of protection		IEC IP40		
Degree of protection against electric shock		Class II		
Proof tracking index (PTI)		175		
Ambient operating temperature		-25 °C to +85 °C (at ambient humidity 60 % max.) (with no icing or condensation)		
Ambient operating humidity		85% max. (for +5°C to +35°C)		
Weight		Approx. 14 g (for D2D-1000)		

Note. The data given above are initial values.

\* For testing conditions, consult your OMRON sales representative.

### Pull-on lock function (D2D-2000 models)

When opening or closing the door, the power ON state of the Switch can be checked with the door left open when applying normal (momentary) operations. By closing the door after maintenance inspection, the Switch will resume the normal momentary operation. (This feature is ideal for conducting the electrical continuity test, inspection, repair, etc. on the Switch after its assembly.)

Example	State	Contact	
		NO-NO	NC-NC
To turn ON the power when the door is closed		ON	OFF
To turn OFF the power when the door is open		OFF	ON
To turn ON the power with the door left open		ON	OFF

### Double Spring Mechanism (D2D-1000/3000 models)

Two return springs are provided for the pin plunger. Thus, if either of the springs is broken, this feature will prevent the Switch from malfunctioning or short-circuiting.

### Direct Contact Opening Mechanism (D2D-1000 models)

Pushing the plunger will effectively break the circuit on the NC side even if a contact weld occurs. Direct Contact Opening Mechanism is not available in NO connection.

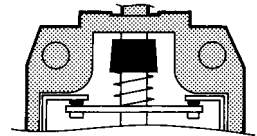

### Approved Safety Standard

#### UL (UL1054) /CSA (CSA C22.2 No.55)

Rated voltage	Model	D2D-1000	D2D-2000	D2D-3000
125 VAC		-	-	3/4HP
250 VAC		16A	10A	16A 1-1/2HP

#### VDE (EN61058-1)

Rated voltage	Model	D2D-1000	D2D-2000	D2D-3000
250 VAC		16 (4) A	10A	16 (4) A

Test conditions: 1E4 (10,000 operations) T85 (0°C to 85°C)

Note. The values in parentheses are the motor load ratings.

### Mounting Holes (Unit: mm)

#### Screw Mounting Hole Dimensions

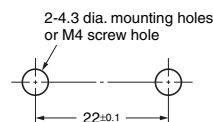

#### Panel Cutout Dimensions (Panel thickness: 1.0 to 2.5 mm)

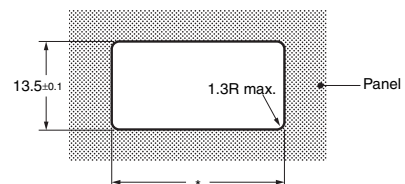

\* For panel of thickness 1.0 is 36.7±0.1  
For panel of thickness 2.5 is 37.0±0.1

## Dimensions (Unit: mm)/Operating Characteristics

### Standard model

#### ●Screw Mounting

D2D-1000  
D2D-1001  
D2D-1002

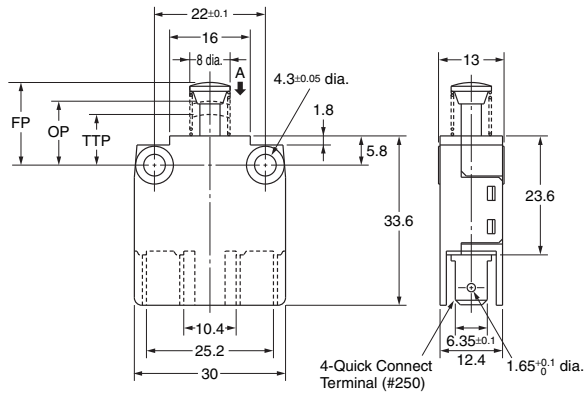

Model		D2D -1000	D2D -1001	D2D -1002
<b>Operating characteristics</b>				
Operating Force	OF Max. (NC-OFF)	2.94 N {300 gf}	-	2.94 N {300 gf}
	(NO-ON)	5.88 N {600 gf}	5.88 N {600 gf}	-
Total Travel Force	TTF Max.	7.35 N {750 gf}	7.35 N {750 gf}	7.35 N {750 gf}
Overtravel	OT Min.	2.3 mm	2.3 mm	5.5 mm
Free Position	FP Max.	16.4 mm	17 mm	16.4 mm
Operating Position	OP (NC-OFF)	15.9±0.4 mm	-	15.9±0.4 mm
	(NO-ON)	12.7±0.4 mm	12.7±0.4 mm	-
Total Travel Position	TTP Max.	10 mm	10 mm	10 mm

#### ●Panel Mounting

D2D-1100  
D2D-1101  
D2D-1102

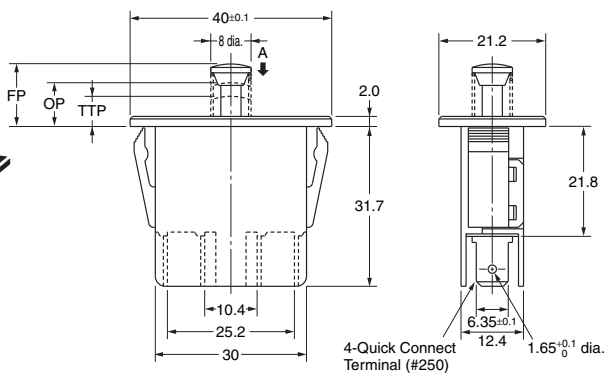
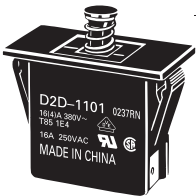

Model		D2D -1100	D2D -1101	D2D -1102
<b>Operating characteristics</b>				
Operating Force	OF Max. (NC-OFF)	2.94 N {300 gf}	-	2.94 N {300 gf}
	(NO-ON)	5.88 N {600 gf}	5.88 N {600 gf}	-
Total Travel Force	TTF Max.	7.35 N {750 gf}	7.35 N {750 gf}	7.35 N {750 gf}
Overtravel	OT Min.	2.3 mm	2.3 mm	5.5 mm
Free Position	FP Max.	12.4 mm	13 mm	12.4 mm
Operating Position	OP (NC-OFF)	11.9±0.4 mm	-	11.9±0.4 mm
	(NO-ON)	8.7±0.4 mm	8.7±0.4 mm	-
Total Travel Position	TTP Max.	6 mm	6 mm	6 mm

#### ●Panel Mounting

D2D-3103

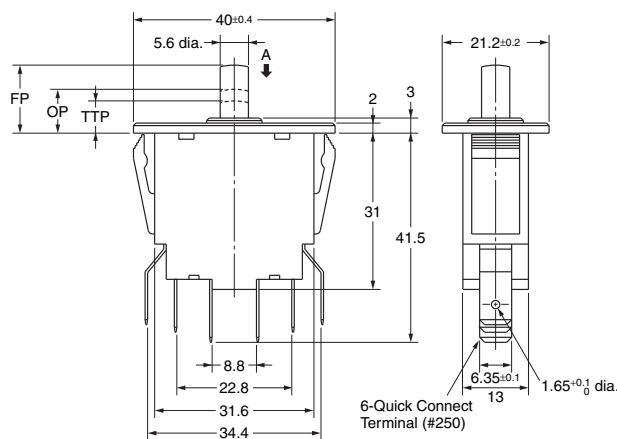
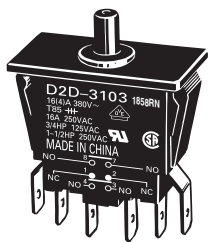

Model		D2D -3103	D2D -3104
<b>Operating characteristics</b>			
Operating Force	OF Max. (NC-OFF)	2.94 N {300 gf}	-
	(NO-ON)	5.88 N {600 gf}	5.88 N {600 gf}
Total Travel Force	TTF Max.	9.81 N {1,000 gf}	9.81 N {1,000 gf}
Overtravel	OT Min.	2.3 mm	2.3 mm
Free Position	FP Max.	12.4 mm	13.5 mm
Operating Position	OP (NC-OFF)	11.9±0.8 mm	-
	(NO-ON)	8.7±0.8 mm	8.7±0.8 mm
Total Travel Position	TTP Max.	6.4 mm	6.4 mm

#### ●Panel Mounting

D2D-3104

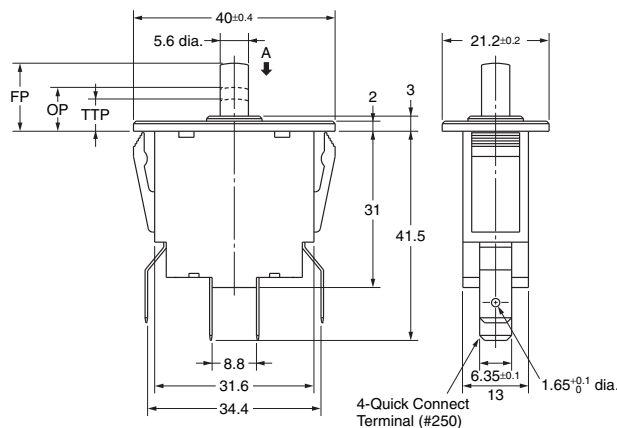
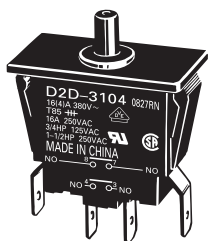

Note 1. Unless otherwise specified, a tolerance of ±0.4 mm applies to all dimensions.  
2. The operating characteristics are for operation in the A direction (↓).

## Pull-on lock model

### ●Screw Mounting D2D-2000

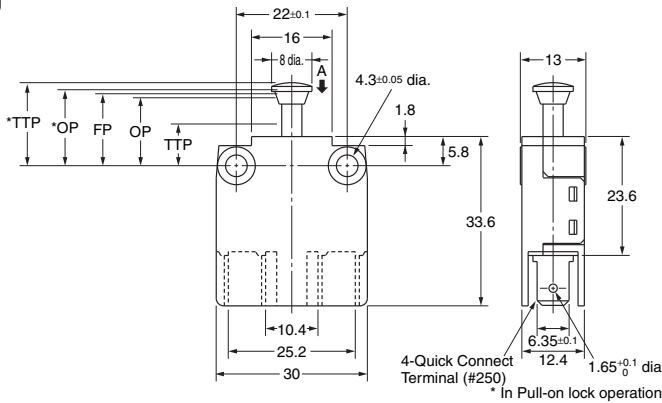

### Momentary Operation (Normal Operation)

Operating characteristics		Model	D2D -2000	D2D -2100
Operating Force	OF Max. (NC-OFF) (NO-ON)		1.96 N {200 gf}	1.96 N {200 gf}
			2.94 N {300 gf}	2.94 N {300 gf}
Total Travel Force		TTF Max.	5.88 N {600 gf}	5.88 N {600 gf}
Overtravel	OT Min.		4.5 mm	4.5 mm
Free Position	FP Max.		14.3 mm	10.3 mm
Operating Position	OP (NC-OFF) (NO-ON)		13.5±0.6 mm	9.5±0.6 mm
			12.7±0.6 mm	8.7±0.6 mm
Total Travel Position		TTP Max.	8.3 mm	4.3 mm

### ●Panel Mounting D2D-2100

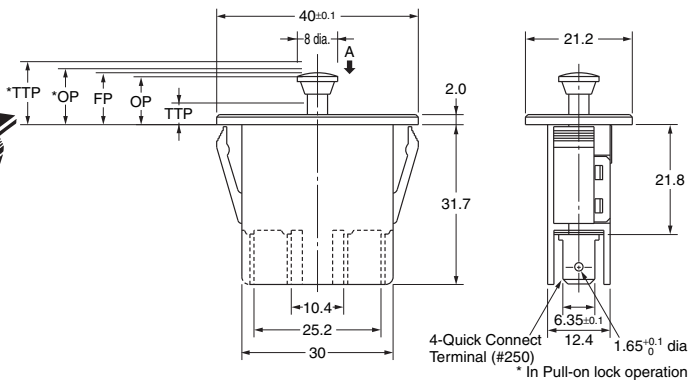
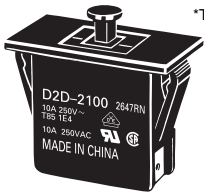

### Pull-on lock Operation

Operating characteristics		Model	D2D -2000	D2D -2100
Operating Force	OF	Max.	19.61 N {2,000 gf}	19.61 N {2,000 gf}
Pretravel	PT	Max.	2 mm	2 mm
Overtravel	OT	Min.	0.4 mm	0.4 mm
Movement Differential		MD Max.	1.5 mm	1.5 mm
Free Position	FP	Max.	14.3 mm	10.3 mm
Operating Position	OP		15.1±0.6 mm	11.1±0.6 mm
			16.5 mm	12.5 mm
Total Travel Position		TTP Max.	16.5 mm	12.5 mm

Note 1. Unless otherwise specified, a tolerance of ±0.4 mm applies to all dimensions.  
2. The operating characteristics are for operation in the A direction (↓).

## Precautions

★Please refer to "Basic Switches Common Precautions" for correct use.

### Correct Use

#### ●Mounting

- Apply operation force to the pin plunger in the direction it operates. Applying forces laterally or from an oblique direction may damage the pin plunger.

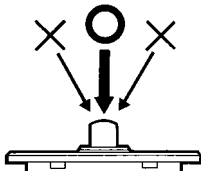

- Use M4 mounting screw with plane washers or spring washers to securely mount the Switch. Tighten the screws to a torque of 0.49 to 0.69 N·m {5 to 7 kg·cm}.

#### ●Wiring

- It is recommended to use sleeve receptacles when connecting with the quick connect terminals.
- Insert the receptacle straight toward the terminal.
- Applying excessive external force horizontally or vertically may cause deformation of terminals and may damage the housings.

#### ●Using Micro Loads

Using a model for ordinary loads to open or close the contact of a micro load circuit may result in faulty contact. It is recommended to use the Switch in the operation range shown below. The minimum applicable load is the N-level reference value. This value indicates the malfunction reference level for the reliability level of 60% ( $\lambda_{60}$ ).

(JIS C5003)

The equation,  $\lambda_{60}=0.5 \times 10^{-6} / \text{operations}$ , indicates that the estimated malfunction rate is less than  $\frac{1}{2,000,000}$  operations with a reliability level of 60%.

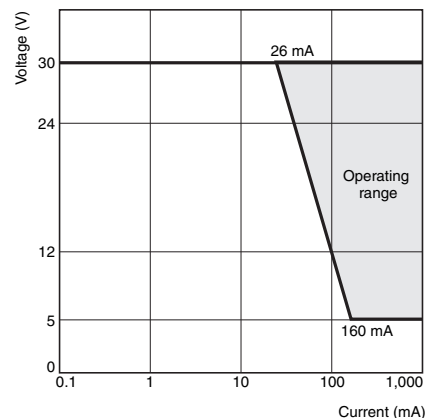

- Application examples provided in this document are for reference only. In actual applications, confirm equipment functions and safety before using the product.
- Consult your OMRON representative before using the product under conditions which are not described in the manual or applying the product to nuclear control systems, railroad systems, aviation systems, vehicles, combustion systems, medical equipment, amusement machines, safety equipment, and other systems or equipment that may have a serious influence on lives and property if used improperly. Make sure that the ratings and performance characteristics of the product provide a margin of safety for the system or equipment, and be sure to provide the system or equipment with double safety mechanisms.

**Note: Do not use this document to operate the Unit.**