

Single Poke Home Contact: Wire-To-Board

Series 70-9296



The Industrial and Solid State Lighting markets continue to look for new products which will reduce size and cost without jeopardizing performance. The new dual-beam boxed contact system from AVX surface mounts to a PCB and provides a simple and reliable wire termination without soldering of the wire. The unique contact design integrates several key features within the stamping to facilitate SMT pickup, wire guidance, high force retention and easy wire removal. Combined, these features provide all of the benefits of a full function connector, without the added cost of the insulator and labor.

This family of 4mm, 3mm, 2mm and 1.7mm closed box contacts accept either solid or stranded wires ranging from 12AWG to 28AWG with current ratings up to 20Amps. Once the contacts are soldered onto the PCB, wires need to be stripped to length (twisted if stranded) and inserted into the open end of the box contact. As the wires are pushed in, upper and lower tines guide the wire down the center of the contact deflecting the right and left contact tines until the wire reaches the wire stop. Wires can be removed by twisting the wire out and or using a small blade removal tool to help release some of the contact force.

APPLICATIONS

- Industrial/Ruggedized Wire-to-Board applications
- Replace hard soldering of wire to a PCB
- Reference Product Specification 201-01-143
- Reference Application Notes 201-01-150

FEATURES AND BENEFITS

- Dual Beam box contact provides maximum mechanical stability and wire retention
- Tape and reel packaged for automated SMT placement
- Staged current rating based on AWG, maximum is 20A (12AWG)
- Increased functionality with the single contact placement ability; multiple contacts and/or specific individual locations

ELECTRICAL

- Voltage Rating: Based on placement distance
- Current Rating: See Matrix Below

ENVIRONMENTAL

- Operating Temperature: -40°C to +125°C

MECHANICAL

- Contact Material: Phosphor Bronze
- Contact Plating: Tin over Nickel
- Durability 5 Cycles

HOW TO ORDER

70
Prefix
70 = Contact

9296
Series

001
Number of Ways
001 = 1

00X
Contact Size

006
Plating Option
Tin all over



Code	Contact Size	Wire Gauge	Max Insulation
017	1.7mm Contact	22-26 AWG	1.3mm Ø (See page 6)
002	2mm Contact	24-28 AWG	1.5mm Ø (See page 6)
003	3mm Contact	18-26 AWG	2.5mm Ø
004	4mm Contact	12-20 AWG	3.4mm Ø

CURRENT RATING

Size	Part Number	12AWG	14AWG	16AWG	18AWG	20AWG	22AWG	24AWG	26AWG	28AWG
4mm	709296001004006	20A	16A	14A	12A	10A				
3mm	709296001003006				12A	10A	8A	7A	5A	
2mm	709296001002006						8A	7A	5A	4A
1.7mm	709296001017006						8A	7A	5A	

Single Poke Home Contact: Wire-To-Board

Series 70-9296

70-9296-001-017-006 1.7MM POKE HOME CONTACT

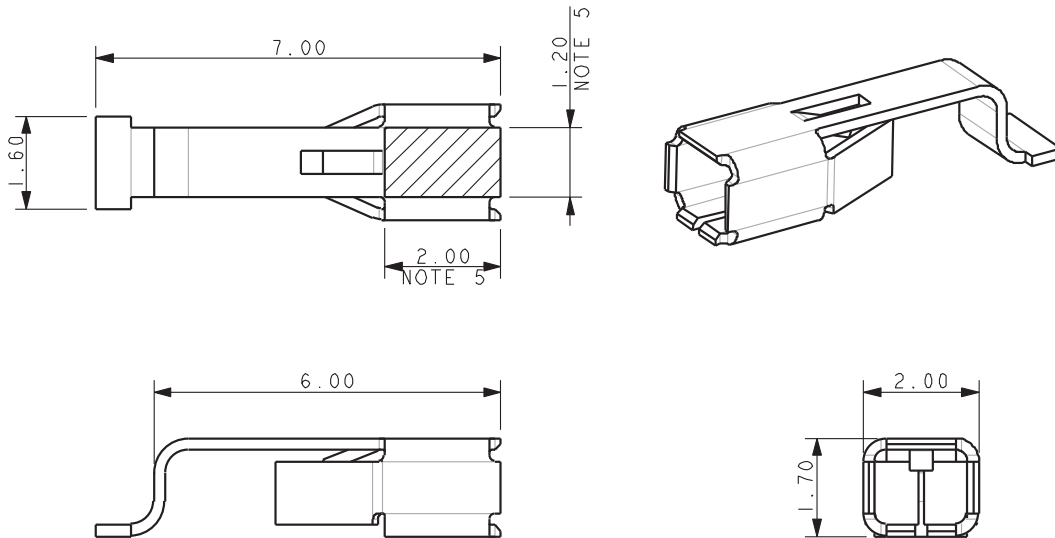

NOTES:

1. FOR FURTHER INFORMATION REFER TO ELCO SPECIFICATION 201-01-143 AND APPLICATION NOTES 201-01-150.
2. MATERIAL: TIN PLATED PHOSPHOR BRONZE.
3. PACKING IN TAPE AND REEL, 4000 PIECES PER REEL.
4. FOR WIRE TRIM DETAILS REFER TO PAGE 6.
5. AREA AVAILABLE FOR PICK AND PLACE.

SUGGESTED PCB LAYOUT

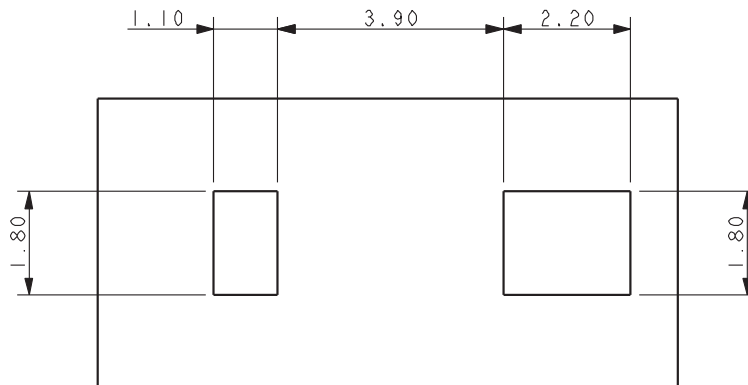

PACKING DETAILS

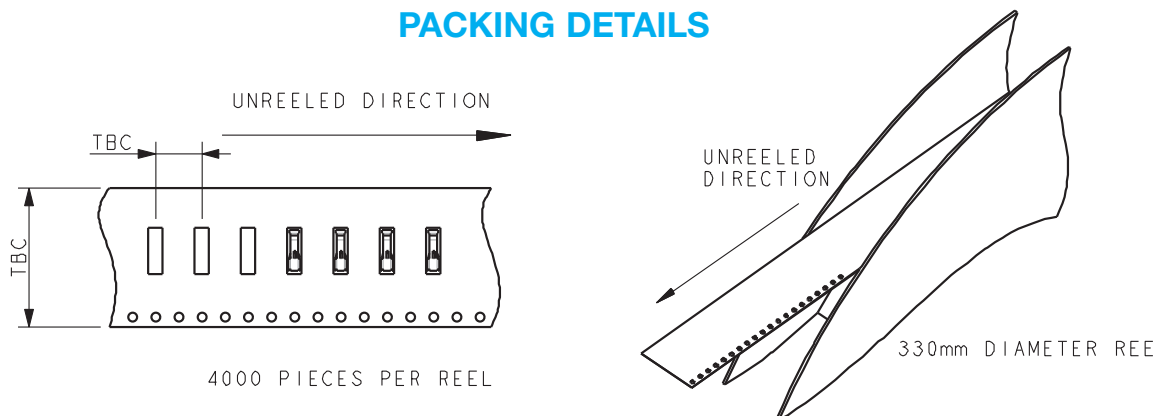

Single Poke Home Contact: Wire-To-Board

Series 70-9296

70-9296-001-002-006 2MM POKE HOME CONTACT

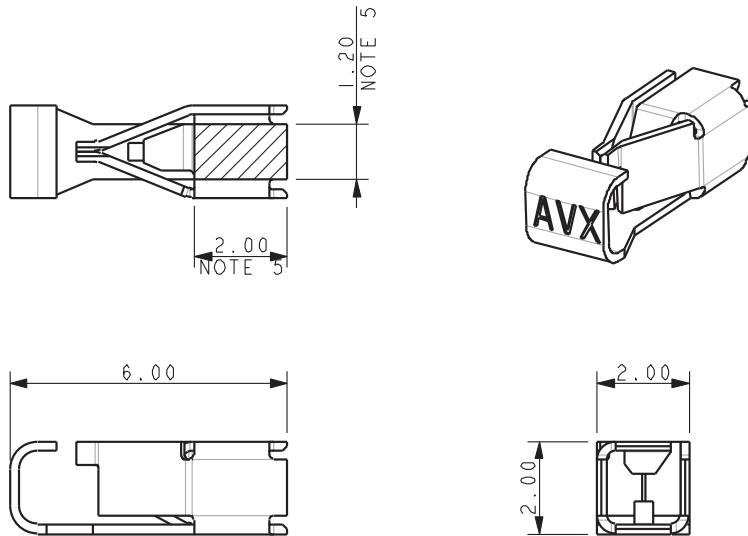

NOTES:

1. FOR FURTHER INFORMATION REFER TO ELCO SPECIFICATION 201-01-143 AND APPLICATION NOTES 201-01-150.
2. MATERIAL: TIN PLATED PHOSPHOR BRONZE.
3. PACKING IN TAPE AND REEL, 3500 PIECES PER REEL.
4. FOR WIRE TRIM DETAILS REFER TO PAGE 6.
5. AREA AVAILABLE FOR PICK AND PLACE.

SUGGESTED PCB LAYOUT

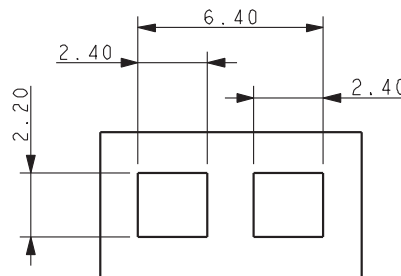

PACKING DETAILS

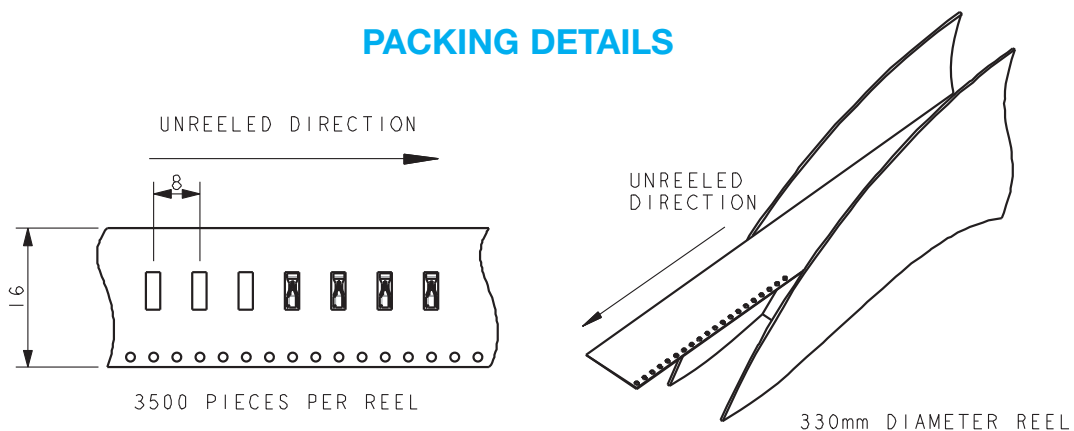

Single Poke Home Contact: Wire-To-Board

Series 70-9296

70-9296-001-003-006 3MM POKE HOME CONTACT

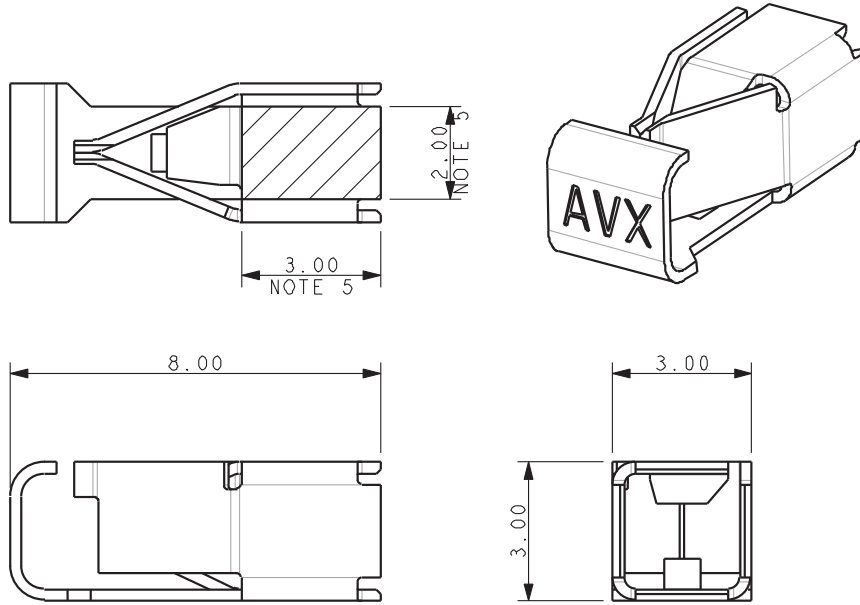

NOTES:

1. FOR FURTHER INFORMATION REFER TO ELCO SPECIFICATION 201-01-143 AND APPLICATION NOTES 201-01-150.
2. MATERIAL: TIN PLATED PHOSPHOR BRONZE.
3. PACKING IN TAPE AND REEL, 2500 PIECES PER REEL.
4. FOR WIRE TRIM DETAILS REFER TO PAGE 6.
5. AREA AVAILABLE FOR PICK AND PLACE.

SUGGESTED PCB LAYOUT

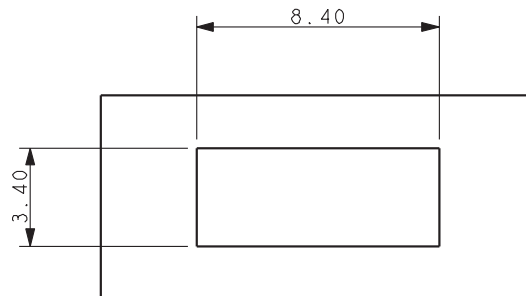

PACKING DETAILS

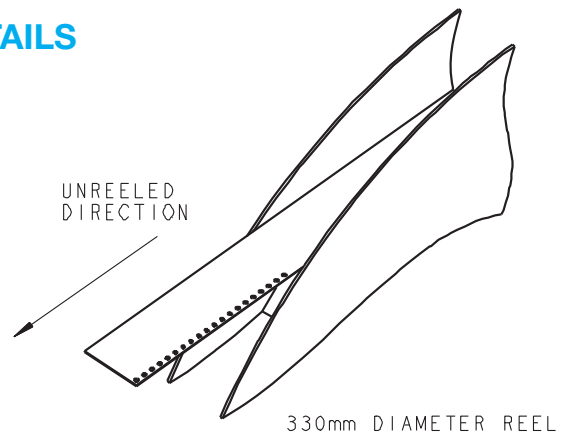
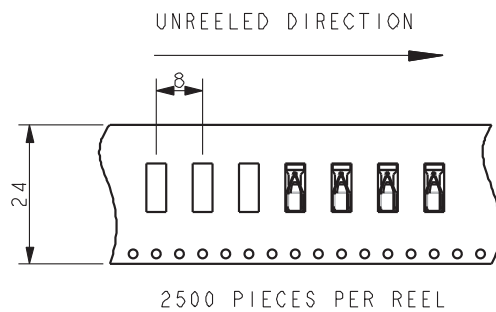

Single Poke Home Contact: Wire-To-Board

Series 70-9296

70-9296-001-004-006 4MM POKE HOME CONTACT

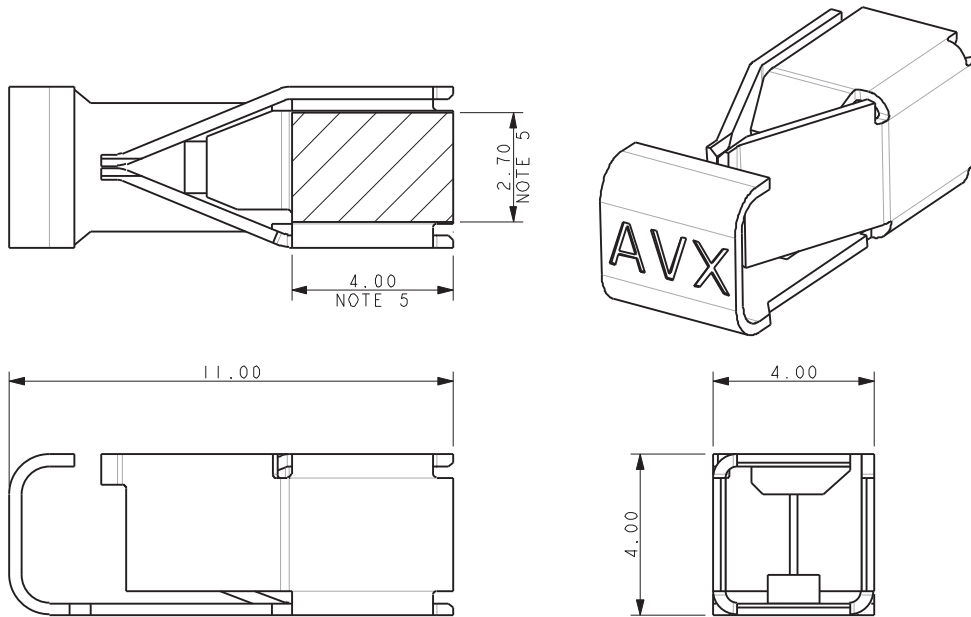

NOTES:

1. FOR FURTHER INFORMATION REFER TO ELCO SPECIFICATION 201-01-143 AND APPLICATION NOTES 201-01-150.
2. MATERIAL: TIN PLATED PHOSPHOR BRONZE.
3. PACKING IN TAPE AND REEL, 2000 PIECES PER REEL.
4. FOR WIRE TRIM DETAILS REFER TO PAGE 6.
5. AREA AVAILABLE FOR PICK AND PLACE.

SUGGESTED PCB LAYOUT

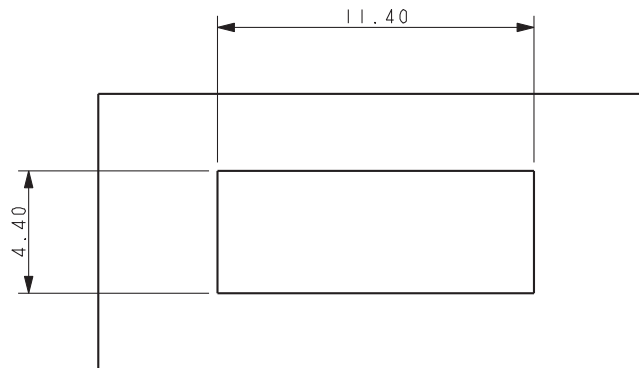

PACKING DETAILS

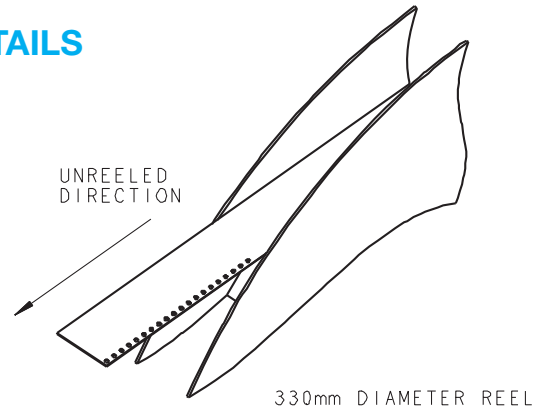
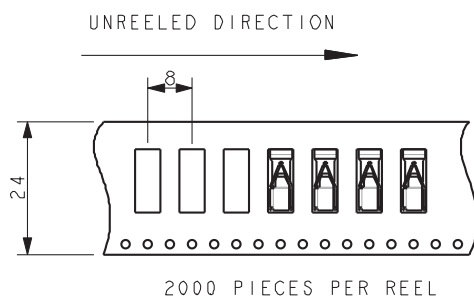

Single Poke Home Contact: Wire-To-Board

Series 70-9296

CONNECTOR ASSEMBLY

FOR FULL DETAILS REFER TO APPLICATION NOTES 201-01-150

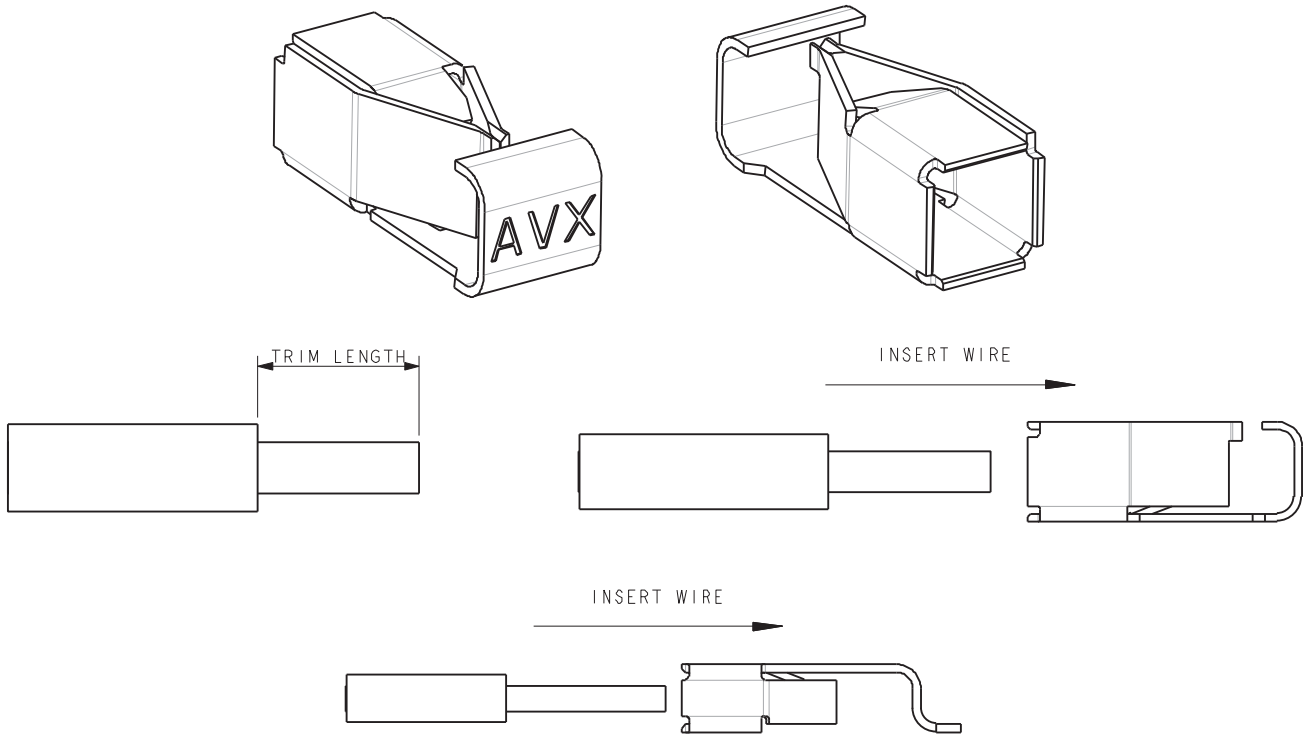

CONTACT	WIRE SIZE	INSULATOR DIAMETER	TRIM LENGTH
70-9206-001-004-006	12AWG and 14AWG	Max 3.4mm	6.5 ± 0.5mm
70-9296-001-004-006	16AWG, 18AWG and 20AWG	Max 2.5mm	5.5 ± 0.5mm
70-9296-001-003-006	18AWG to 25AWG	Max 2.5mm	3.5 ± 0.5mm
70-9296-001-002-006	22AWG to 28AWG	Max 1.5mm	3.5 ± 0.5mm
70-9296-001-002-006	22AWG to 28AWG	1.5mm to 2.0mm	5.5 ± 0.5mm*
70-9296-001-017-006	22AWG to 26AWG	Max 1.3mm	4.0 ± 0.5mm
70-9296-001-017-006	22AWG to 26AWG	1.3mm to 1.7mm	6.0 ± 0.5mm*

* Wire insulation butts on end of contact

CONTACT OPENING TOOL 06-9296-7001-01-000

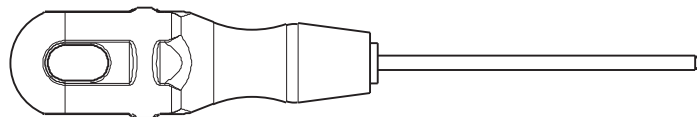

TOOL TO OPEN THE CONTACT TO INSERT/WITHDRAW WIRE.
REFER TO APPLICATION NOTES 201-01-150.