

## Kit Description

Rev. 1.00 / March 2013

# ZLED7015

ZLED7015KIT-E1 Evaluation Kit Description

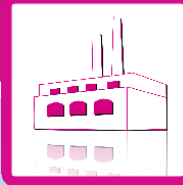
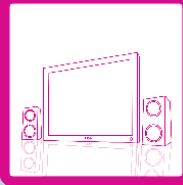

*Wise and Efficient*



*LED Lighting ICs*

# ZLED7015

ZLED7015KIT-E1 Evaluation Kit



The Analog Mixed Signal Company



## Important Notice

### Restrictions in Use

ZMDI's ZLED7015KIT-E1 Evaluation Kit hardware is designed for ZLED7015 demonstration, evaluation, laboratory setup, and module development only. The ZLED7015KIT-E1 Evaluation Kit hardware must not be used for module production or production test setups.

### Disclaimer

Zentrum Mikroelektronik Dresden AG (ZMD AG) shall not be liable for any damages arising out of defects resulting from

- (i) delivered hardware and software
- (ii) non-observance of instructions contained in this manual and in any other documentation provided to user, or
- (iii) misuse, abuse, use under abnormal conditions or alteration by anyone other than ZMD AG.

To the extent permitted by law, ZMD AG hereby expressly disclaims and user expressly waives any and all warranties, whether express, implied or statutory, including, without limitation, implied warranties of merchantability and of fitness for a particular purpose, statutory warranty of non-infringement and any other warranty that may arise by reason of usage of trade, custom or course of dealing.

## Contents

1	Kit Contents .....	4
2	Kit Description .....	4
2.1.	ZLED7015 Overview .....	4
2.2.	ZLED7015KIT-E1 Evaluation Board Overview.....	4
2.3.	Connections.....	5
2.4.	Power Supply.....	6
2.5.	Circuit Operation.....	6
2.6.	Schematic Diagram .....	7
3	Ordering Information .....	8
4	Related Documents.....	8
5	Glossary .....	8
6	Document Revision History.....	9

# ZLED7015

ZLED7015KIT-E1 Evaluation Kit



The Analog Mixed Signal Company



## List of Figures

Figure 2.1	ZLED7015KIT-E1 Evaluation Board (Top View) .....	5
Figure 2.2	ZLED7015KIT-E1 Schematic Diagram .....	7

## List of Tables

Table 2.1	Connections for the Evaluation Board .....	5
-----------	--	---

For more information, contact ZMDI via [LED\\_Drivers@zmdi.com](mailto:LED_Drivers@zmdi.com).



## 1 Kit Contents

The ZLED7015KIT-E1 Evaluation Kit includes the following:

- ZLED7015-E1 Evaluation Board v.X
- Five ZLED7015 samples, MSOP10 with thermal pad package
- *ZLED7015KIT-E1 Evaluation Kit Start-up Information*
- *Kit Disclaimer*

The ZLED7015KIT-E1 Evaluation Kit is fully assembled and ready for immediate operation.

## 2 Kit Description

### 2.1. ZLED7015 Overview

The ZLED7015KIT-E1 Evaluation Kit provides a quick and easy method for evaluating the ZLED7015 within its basic application circuit. Reading the *ZLED7015 Data Sheet* before using the Evaluation Kit is recommended for understanding the operation of the ZLED7015 and the Evaluation Board.

The ZLED7015 is a constant current boost converter with an internal FET switch. The step-up converter topology allows series connection of multiple white LEDs so that the LED currents are identical for uniform brightness. The nominal output current can be set by an external resistor with the option to also dim the brightness of the LEDs with a PWM signal or DC voltage. A low 0.3V feedback voltage minimizes power loss in the current setting resistor for better efficiency. The over-voltage protection (OVP) circuit safeguards the chip and the system even if the load is not connected. The ZLED7015 is available in an MSOP-10 package.

The ZLED7015 IC is designed for LED current drive applications of up to 1.8A.

The main features of ZLED7015 driver are

- 6VDC to 30VDC supply voltage
- High efficiency: up to 95%
- PWM or DC voltage dimming control
- Fast 1.0MHz switching frequency
- Internal high power 35V MOSFET switch
- Adjustable over-voltage protection (including open LED string detection)
- Over-temperature protection

### 2.2. ZLED7015KIT-E1 Evaluation Board Overview

The Evaluation Board contains a standard 4-pin terminal connector to allow the user to easily connect and supply an LED's board. The Evaluation Board also has two LED power pads (LED+ and LED-) to provide more flexibility in supplying a power LED or LED string. A 10 $\mu$ H shielded inductor sets the nominal frequency around 300kHz. The shielded inductor has been selected to minimize radiated EMI. The layout with any switching regulator is crucial to minimize radiated EMI. This reference design keeps the critical track lengths to a minimum. Ground has been maximized around critical areas.

# ZLED7015

ZLED7015KIT-E1 Evaluation Kit



The Evaluation Board offers the following features and benefits:

- Wide input voltage range (see section 2.4).
- Standard 2.54mm 4-pin header for attaching of LEDs and additional duplicate SMD pads (LED- , LED+).
- Standard 2.54mm 2-pin male header and alternative duplicate SMD pads for power supply.
- Standard 2.54mm 3-pin male header for dimming the LED brightness with an external PWM signal.
- All devices are SMD and on the same side of the board (as shown in the top view given in Figure 2.1).
- Maximized power ground copper on top and bottom sides with thermal vias for good heat distribution.
- Track connecting R2 (current sense resistor) to ZLED7015 is as short as possible (sense tracks).
- The C3 filter capacitor and COUT are connected as close as possible to the LED output pins.
- The flyback current path is as short as possible to ensure system precision and efficiency.

**Figure 2.1 ZLED7015KIT-E1 Evaluation Board (Top View)**

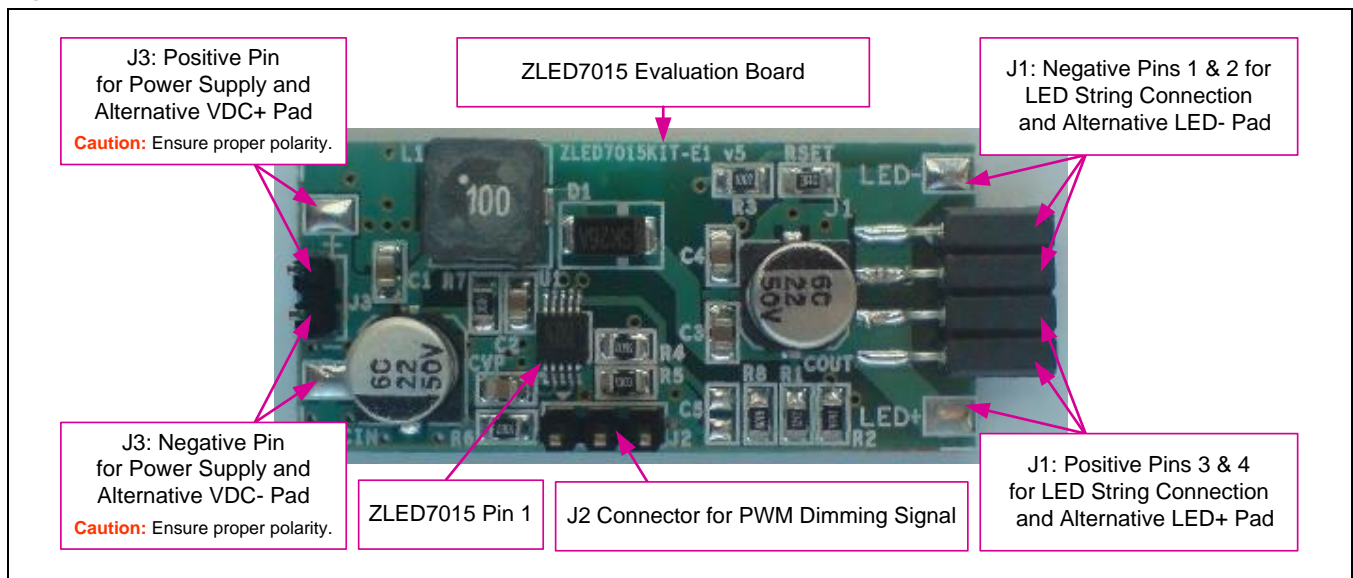

## 2.3. Connections

Refer to Figure 2.1 for an illustration of the following set up for the Evaluation Board.

**Table 2.1 Connections for the Evaluation Board**

Connector	Description
J1	Standard 2.54mm 4-pin female header with the following connections. Pins 1 and 2: Negative pole for voltage output to drive the LED string (also see LED- pad) Pins 3 and 4: Positive pole for voltage output to drive the LED string (also see LED+ pad)
J2	Standard 2.54mm 3-pin male header for dimming the brightness of the LEDs with an external PWM signal or DC voltage.
J3	Standard 2.54mm 2-pin male header for power supply. Input voltage range: 6VDC to 30VDC. See section 2.4 for additional requirements.

# ZLED7015

ZLED7015KIT-E1 Evaluation Kit



Connector	Description
VDC+	Positive pad for an optional alternative connection for the power supply (instead of J3).
VDC-	Negative pad for an optional alternative connection for the power supply (instead of J3).
LED+	Positive pad for an optional alternative connection for the positive ZLED7015 driver supply voltage (instead of J1, pins 3 and 4).
LED-	Negative pad for an optional alternative connection for the negative ZLED7015 driver supply voltage (instead of J1, pins 1 and 2).

## 2.4. Power Supply

The Evaluation Board requires a DC power supply of  $\geq 6V$  for the LED string, but it also must be 3V higher than the normally working output voltage (the total forward voltage of the LED or the LED string).



**Caution:** Ensure proper polarity when making connections. The system is not reverse polarity protected.

See section 2.3 for connection options for the power supply.

## 2.5. Circuit Operation

The reference current on the Evaluation Board has been set to 100mA but can be adjusted by changing the Rset set resistor according to the formula:

$$I_{LED} = V_{FB} / R_{SET}, [A]$$

### Where

$I_{LED}$  = Average output current through the LED(s) in amperes

$V_{FB}$  = Internal feedback reference voltage of the ZLED7015: approx. 0.3V

$R_{SET}$  = Nominal current output setting resistor, which is approx. 3Ω on the Evaluation Board

For  $R_{SET} = 3.0\Omega \rightarrow I_{LED} = 0.1A$

For detailed calculations about dimming control, PWM signal control, and setting the over-voltage protection level, refer to the ZLED7015 datasheet.

# ZLED7015

ZLED7015KIT-E1 Evaluation Kit



## 2.6. Schematic Diagram

Figure 2.2 ZLED7015KIT-E1 Schematic Diagram

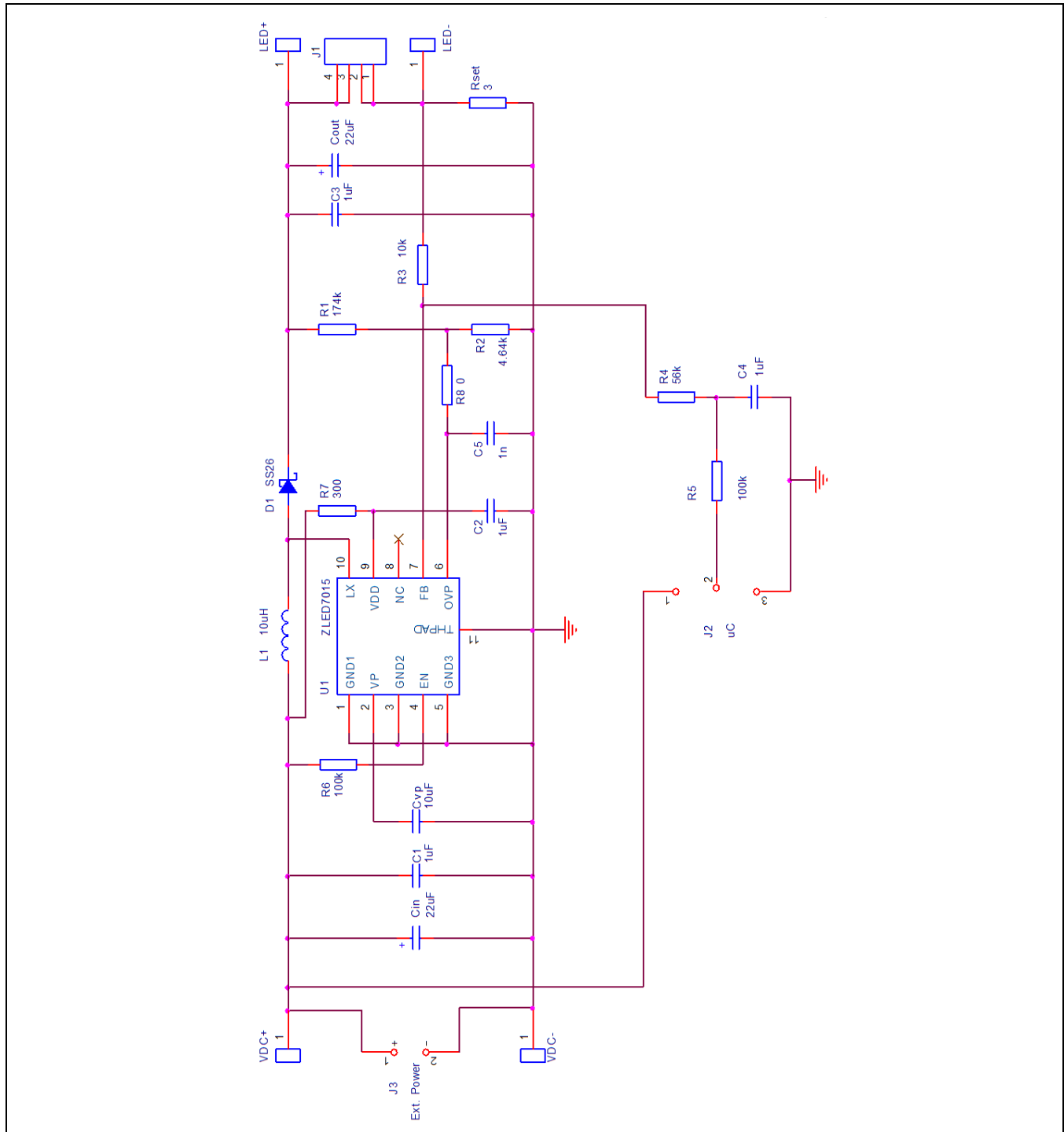

# ZLED7015

ZLED7015KIT-E1 Evaluation Kit



## 3 Ordering Information

Product Sales Code	Description
ZLED7015KIT-E1	ZLED7015KIT-E1 Evaluation Kit VX.x including 5 IC samples

## 4 Related Documents

Note “Rev\_X.x” refers to the latest version of the document.

Document	File Name
ZLED7015 Datasheet	<i>ZLED7015_DataSheet_Rev_X.x.pdf</i>

Visit ZMDI’s website [www.zmdi.com](http://www.zmdi.com) or contact your nearest sales office for the latest version of these documents.

## 5 Glossary

Term	Description
LED	Light Emitted Diode
EMI	Electromagnetic Interference
MOSFET	Metal–Oxide–Semiconductor Field Effect Transistor
PCB	Printed Circuit Board
PWM	Pulse Width Modulation
MSOP10	Mini Small Outline Package



# ZLED7015

ZLED7015KIT-E1 Evaluation Kit

**ZMDI**<sup>®</sup>

The Analog Mixed Signal Company



## 6 Document Revision History

Revision	Date	Description
1.00	March 6, 2013	First release.

Sales and Further Information		<a href="http://www.zmdi.com">www.zmdi.com</a>	<a href="mailto:LED_Drivers@zmdi.com">LED_Drivers@zmdi.com</a>	
<b>Zentrum Mikroelektronik Dresden AG</b> Global Headquarters Grenzstrasse 28 01109 Dresden, Germany  Central Office: Phone +49.351.8822.0 Fax +49.351.8822.600	<b>ZMD America, Inc.</b> 1525 McCarthy Blvd., #212 Milpitas, CA 95035-7453 USA  USA Phone +855.275.9634 Phone +408.883.6310 Fax +408.883.6358	<b>Zentrum Mikroelektronik Dresden AG, Japan Office</b> 2nd Floor, Shinbashi Tokyu Bldg. 4-21-3, Shinbashi, Minato-ku Tokyo, 105-0004 Japan  Phone +81.3.6895.7410 Fax +81.3.6895.7301	<b>ZMD FAR EAST, Ltd.</b> 3F, No. 51, Sec. 2, Keelung Road 11052 Taipei Taiwan  Phone +886.2.2377.8189 Fax +886.2.2377.8199	<b>Zentrum Mikroelektronik Dresden AG, Korea Office</b> U-space 1 Building 11th Floor, Unit JA-1102 670 Sampyeong-dong Bundang-gu, Seongnam-si Gyeonggi-do, 463-400 Korea  Phone +82.31.950.7679 Fax +82.504.841.3026
<b>European Technical Support</b> Phone +49.351.8822.7.772 Fax +49.351.8822.87.772	<b>DISCLAIMER:</b> This information applies to a product under development. Its characteristics and specifications are subject to change without notice. Zentrum Mikroelektronik Dresden AG (ZMD AG) assumes no obligation regarding future manufacture unless otherwise agreed to in writing. The information furnished hereby is believed to be true and accurate. However, under no circumstances shall ZMD AG be liable to any customer, licensee, or any other third party for any special, indirect, incidental, or consequential damages of any kind or nature whatsoever arising out of or in any way related to the furnishing, performance, or use of this technical data. ZMD AG hereby expressly disclaims any liability of ZMD AG to any customer, licensee or any other third party, and any such customer, licensee and any other third party hereby waives any liability of ZMD AG for any damages in connection with or arising out of the furnishing, performance or use of this technical data, whether based on contract, warranty, tort (including negligence), strict liability, or otherwise.			
<b>European Sales (Stuttgart)</b> Phone +49.711.674517.55 Fax +49.711.674517.87955				

Evaluation Kit March 6, 2013	© 2013 Zentrum Mikroelektronik Dresden AG — Rev. 1.00 All rights reserved. The material contained herein may not be reproduced, adapted, merged, translated, stored, or used without the prior written consent of the copyright owner. The information furnished in this publication is subject to changes without notice.	9 of 9
---------------------------------	---	--------