

LMK040xx Evaluation Board

User's Guide



November 2013
SNAU045A



LMX040xx

Precision Clock Conditioner with Dual PLLs and Integrated VCO
Evaluation Board Operating Instructions

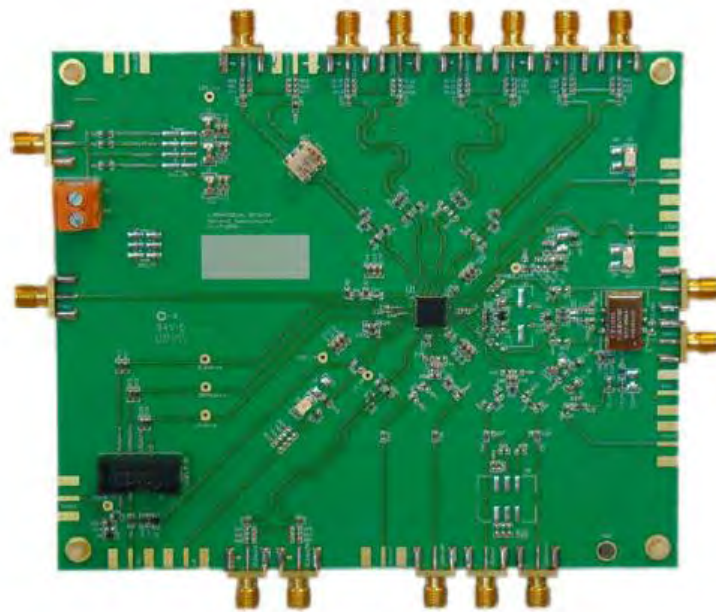

TABLE OF CONTENTS

EQUIPMENT	4
BASIC OPERATION.....	5
LMK040XX BOARD INFORMATION	11
XTAL OSC OPTION PLL 1 LOOP FILTER.....	16
XTAL OPTION PLL 2 LOOP FILTER	16
100 MHz VCXO OPTION PLL 1 LOOP FILTER	17
100 MHz VCXO OPTION PLL 2 LOOP FILTER.....	17
61.44 MHz VCXO OPTION PLL 1 LOOP FILTER	17
61.44 MHz VCXO PLL 2 LOOP FILTER.....	18
EVALUATION BOARD NOTES.....	18
EVALUATION BOARD INPUTS/OUTPUTS	18
TYPICAL PHASE NOISE PERFORMANCE	21
APPENDIX B: BOARD LAYERS STACKUP.....	28
APPENDIX C: BILL OF MATERIALS	29
APPENDIX D: TYPICAL BALUN BOARD FREQUENCY RESPONSE.....	32
APPENDIX E: CHANGING ACTIVE ON-BOARD OSCILLATOR FOR PLL1	33
APPENDIX F: QUICK START FOR EVM COMMUNICATION	39

Equipment

Power Supply

The Power Supply should be a low noise power supply. An Agilent 6623A Triple power supply with LC filters on the output to reduce noise was used in creating these evaluation board instructions.

Phase Noise / Spectrum Analyzer

For measuring phase noise an Agilent E5052A is recommended. An Agilent E4445A PSA Spectrum Analyzer with the Phase Noise option is also usable although the architecture of the E5052A is superior for phase noise measurements. At frequencies less than 100 MHz the local oscillator noise of the PSA is too high and measurements will be of the local oscillator, not the device under test.

Oscilloscope

The oscilloscope and probes should be capable of measuring the output frequencies of interest when evaluating this board. The Agilent Infiniium DSO81204A was used in creating these evaluation board instructions.

Reference Oscillator

The on board crystal oscillator will provide a low noise reference signal to the device at offsets greater than 1 kHz.

Note: The default loop filter has a loop bandwidth of ~60 kHz. Inside the loop bandwidth of a PLL the noise is greatly affected by any noise on the reference oscillator (OSCin). Therefore any noise on the oscillator less than 60 kHz will be passed through and seen on the outputs. For this reason the main output of a Signal Generator is not recommended for driving OSCin in this setup.

Basic Operation

1. Connect a low noise **3.3 V** power supply to the **VCC SMA** connector. If there is no jumper between VccSMA and VccAUXPlane, either install a jumper or connect a 3.3VDC supply to the VCCAux SMA Connector located at the top left of the board.

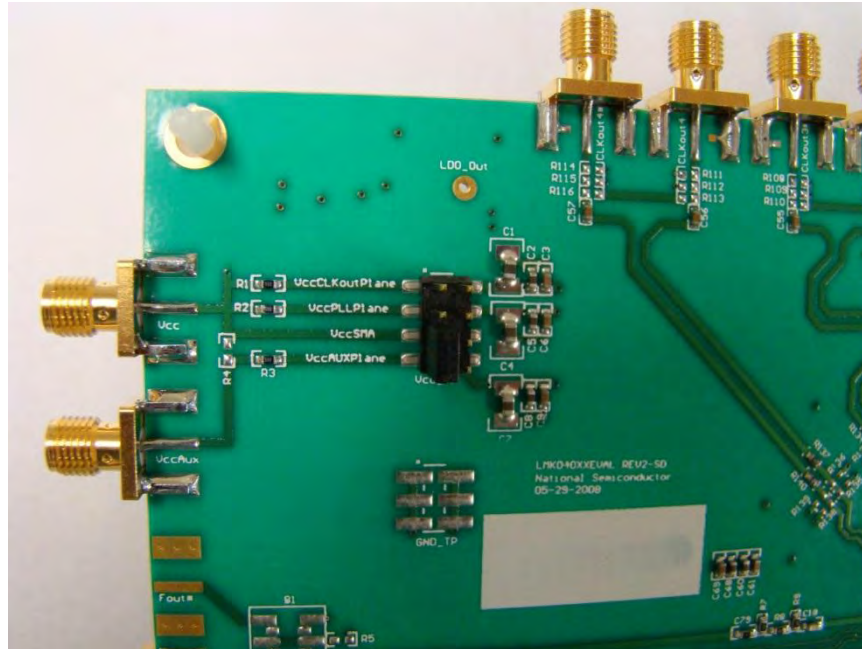

2. Connect a low noise reference clock source (122.88 MHz for the XTAL option or 61.44 MHz VCXO option, 10 MHz for the 100 MHz VCXO option) to the CLKin0* SMA connector (CLKin0 may be left unconnected, as the default configuration of the board uses a single-ended input for the reference). ***See note below:

*****NOTE:** This is the default reference input. The power level of the reference input should be 6 dBm +/- 1 dBm for best performance. The reference input to the LMK040XX is AC coupled so the reference source may be either AC or DC biased. The default signal path configuration is singled-ended. Using a differential reference source requires modification of the board. A sinusoidal or square signal may be used, though better performance may be obtained with a higher slew rate on the input clock.

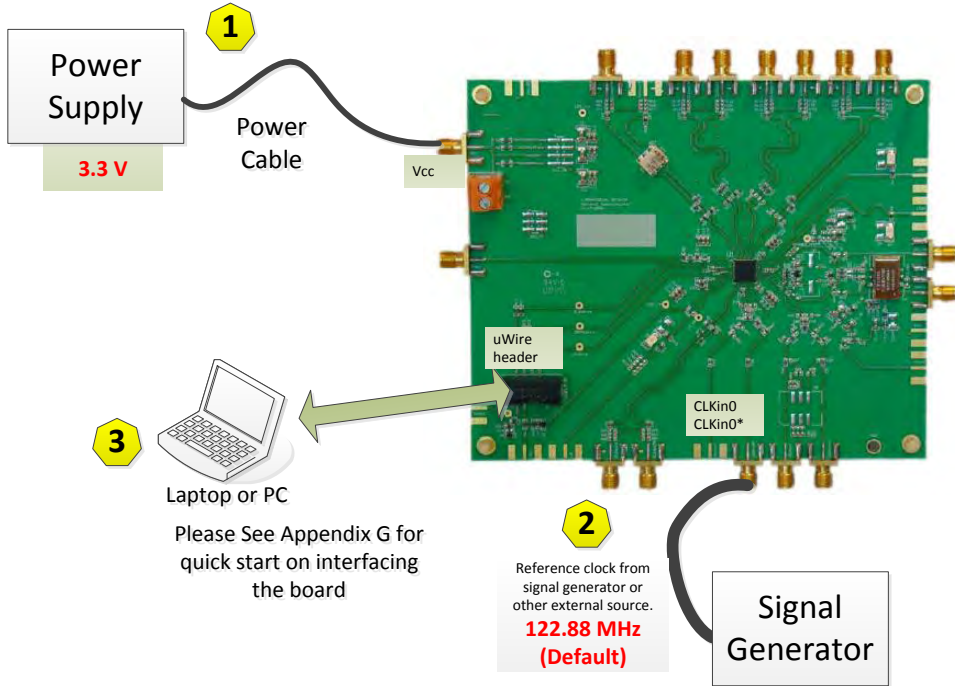

3. Please see **Appendix D** for quick start on interfacing the board. Connect PC to the **uWire** header.
4. Start CodeLoader4.exe
5. Choose the device on the evaluation board, “Select Device” → “Clock Conditioners”

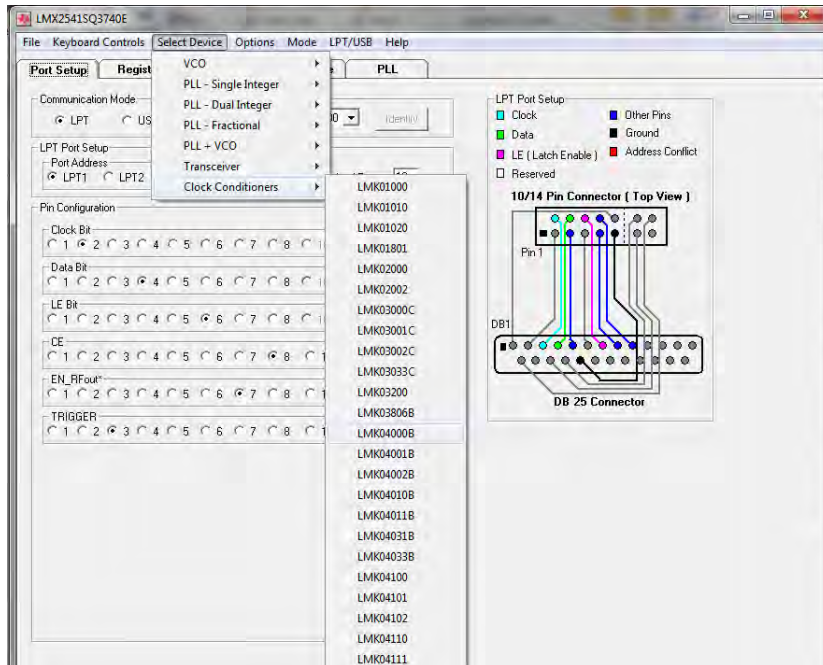

6. Configure the tabs as you would like to test. See notes below:

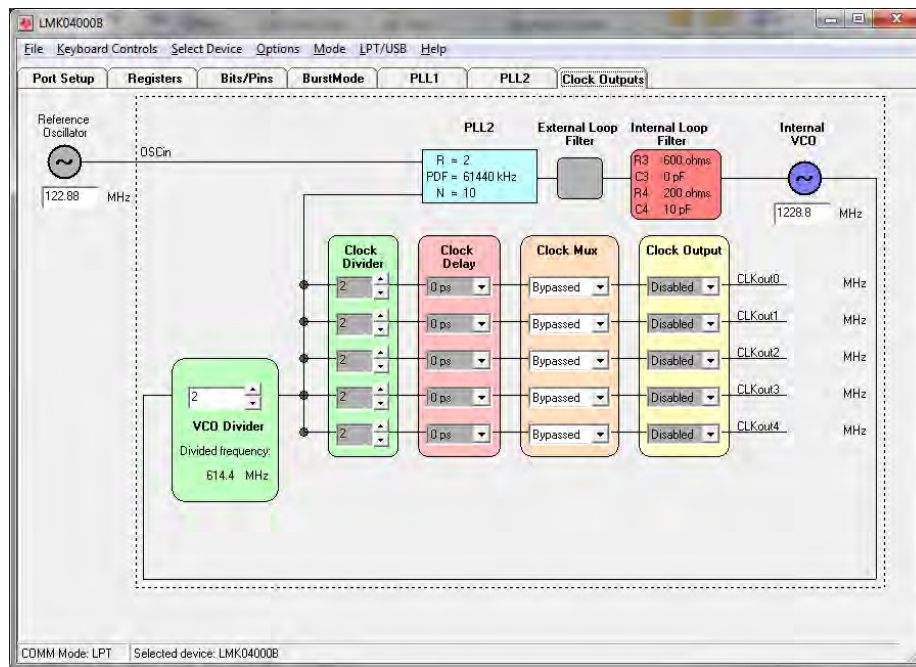

***The clock outputs tab allows the user to Enable/Disable individual clock channels, select the clock mode (Bypass/Divided/ Delayed/ Divided & Delayed), set the channel delay value (if Delay is enabled), and the channel divider value (2,4,6,...,510).

This tab also allows the user to select the VCO Divider value (2,3,...,8). Note that the total PLL2 N divider value is composed of both the VCO Divider value and the N value shown in the blue box in the image, and is given by:
 $N_{TOTAL} = VCO\ Divider * N$.

Clicking on the blue box that contains R, PDF and N values takes the user to the PLL2 tab where these values may be changed.

Clicking on the components in the box containing the Internal Loop Filter values allows the user to change these component values.

The Reference Oscillator value field may be changed in either the Clock Outputs tab or the PLL2 tab. Note this value MUST match the value of the on-board VCXO (or XTAL option).

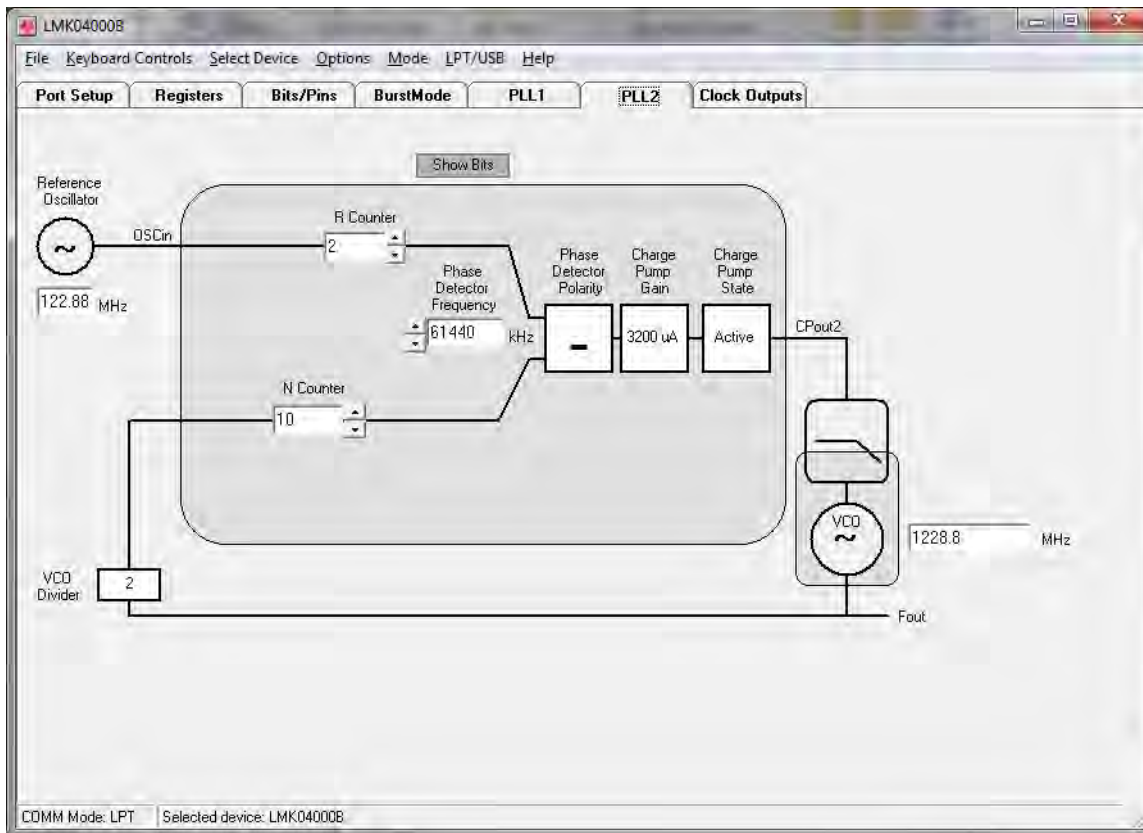

The PLL2 tab allows the user to change:

- VCO frequency
- PLL2 Phase detector frequency
- PLL2 R-counter value
- PLL2 N-counter value
- The frequency of the external VCXO (or XTAL oscillator). **Note: This value must be entered in both the PLL1 and PLL2 tabs.**
- PLL2 Charge pump gain
- PLL2 Charge pump state.

Any changes made on this tab are reflected in the Clock Outputs tab. Note that the PLL2 Phase Detector polarity is fixed and cannot be changed by the user. Also note that the VCO frequency should conform to the specified frequency range for the device (see Table 1).

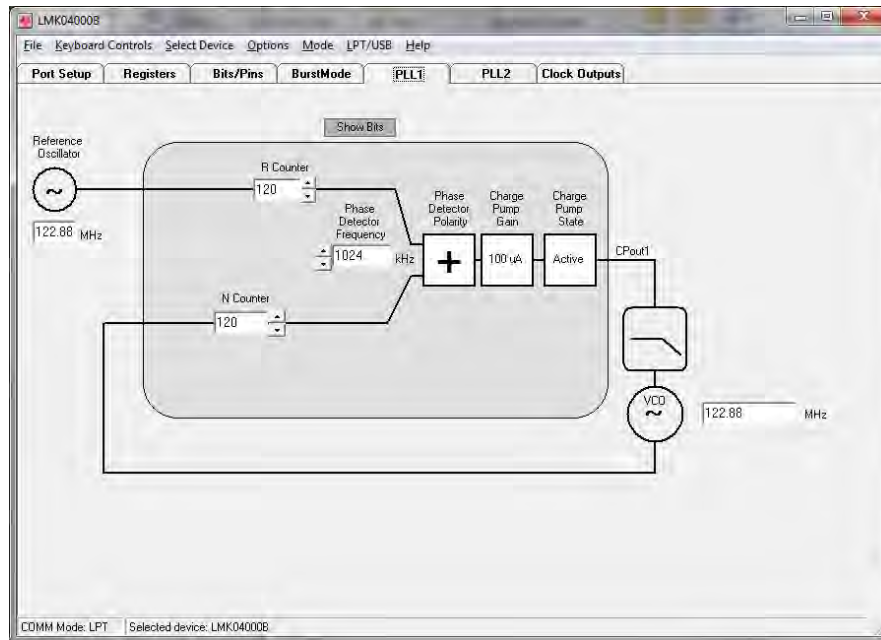

The PLL1 tab allows the user to change:

- External VCXO (or XTAL oscillator) frequency. **Note: This value must be entered in both the PLL1 and PLL2 tabs.**
- PLL1 Phase detector frequency
- PLL1 R-counter value
- PLL1 N-counter value
- CLKin (Reference) oscillator frequency
- PLL1 Phase Detector polarity (external VCXO tuning slope)
- PLL1 Charge pump gain
- PLL1 Charge pump state.

Note that the value entered in the **Reference Oscillator** frequency field on the PLL1 tab must match the **Reference Oscillator** frequency entered on the PLL2 tab.



Figure 1. Bits/Pins tab.

The Bits/Pins tab allows the user to:

- setup various clock output options. This will also be reflected on the **Clock Outputs** tab.
- Manipulate GOE and SYNC signal states (through the 10-pin header)
- Select internal loop filter components for PLL2
- Select Reference clock functional mode: CLKin_SEL (Manual or Auto-revertive)
- Select the Loss-of-Signal (LOS) output type (LOS_TYPE).
- Select the reference clock input buffer type: CLKin0_BUFTYPE and CLKin1_BUFTYPE (MOS or Bipolar junction)
- Enable/disable crystal mode: EN_PLL2_XTAL.
- Enable/disable PLL2 reference clock (OSCin) frequency doubler mode: EN_PLL2_REF2X.
- Set the OSCin (VCXO or XTAL) frequency (OSCin_FREQ). **NOTE: This value should match the Reference Oscillator values entered in the PLL1 and PLL2 tabs. It is important to enter the correct frequency value in this field, as it is used by the internal state machine of the LMK040XX to execute its calibration and tuning routine for the internal VCO.** An incorrect value may result in an unlocked condition for the synthesizer.

LMK040xx Board Information

The LMK040xxB Evaluation Board simplifies evaluation of the LMK040xxB Precision Clock Conditioner with Dual PLLs and Integrated VCO. See **Appendix H** for interfacing the board.

The *CodeLoader* software will run on a Windows 7 or Windows XP PC. The *CodeLoader* software is used to program the internal registers of the LMK040xxB device through a LPT or USB2ANY-uWire interface.

The following block diagram illustrates the functional architecture of the LMK040xxB clock conditioner. It features a cascaded, dual PLL arrangement, available internal loop filter components for PLL2, internal VCO with PLL2 for frequency synthesis, and clock distribution section with individual channel dividers and delay adjustment blocks. The dual reference clock input to PLL1 provides fail-safe redundancy for phase locked loop operation. The cascaded PLL architecture allows PLL1 to be used as a jitter cleaner for an incoming reference clock that contains excessive phase noise. This requires the user to select an external oscillator (VCXO or crystal) that provides the desired phase noise performance at the output of the clock channels. This external oscillator becomes the reference clock for PLL2 and along with the phase noise characteristics of PLL2 and the internal VCO, determines the final phase noise performance at F_{OUT} and the output of the clock distribution section.

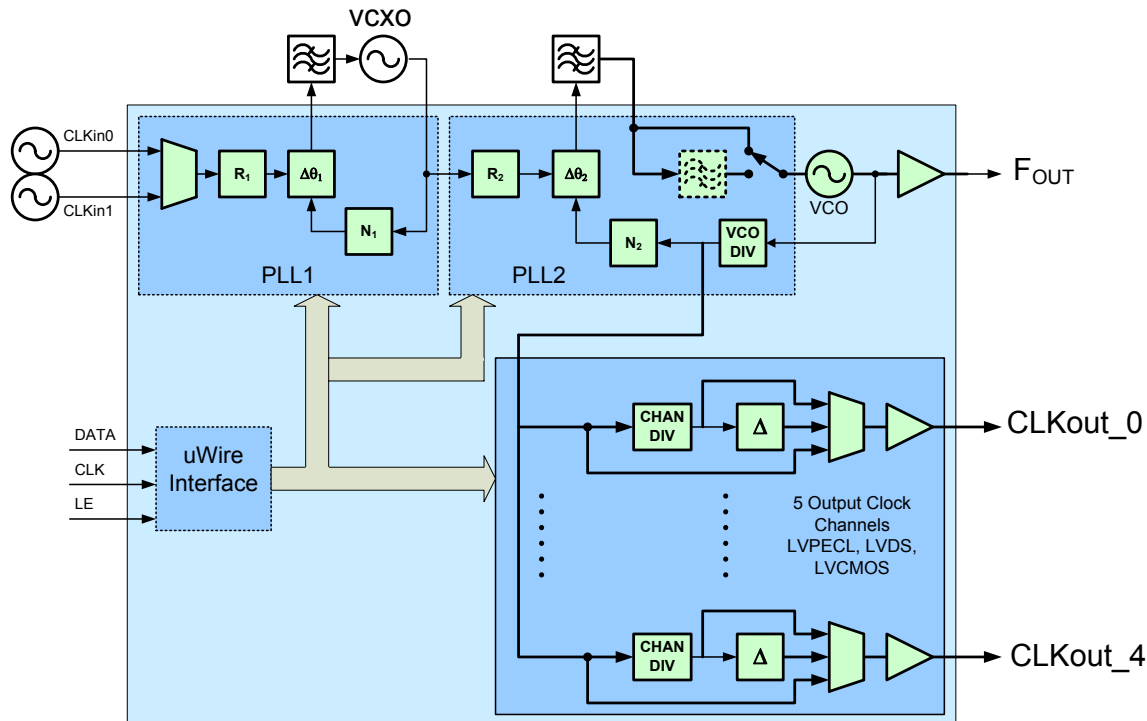

Figure 2. Functional Block Diagram of the LMK040xxB Dual PLL Precision Clock Conditioner with External VCXO module.

PLL1 has been designed to work with either an off-the-shelf VCXO package or with a user -designed discrete implementation that employs a crystal resonator and associated tuning components. The following block diagram shows an example of a discretely implemented VCXO using a crystal resonator.

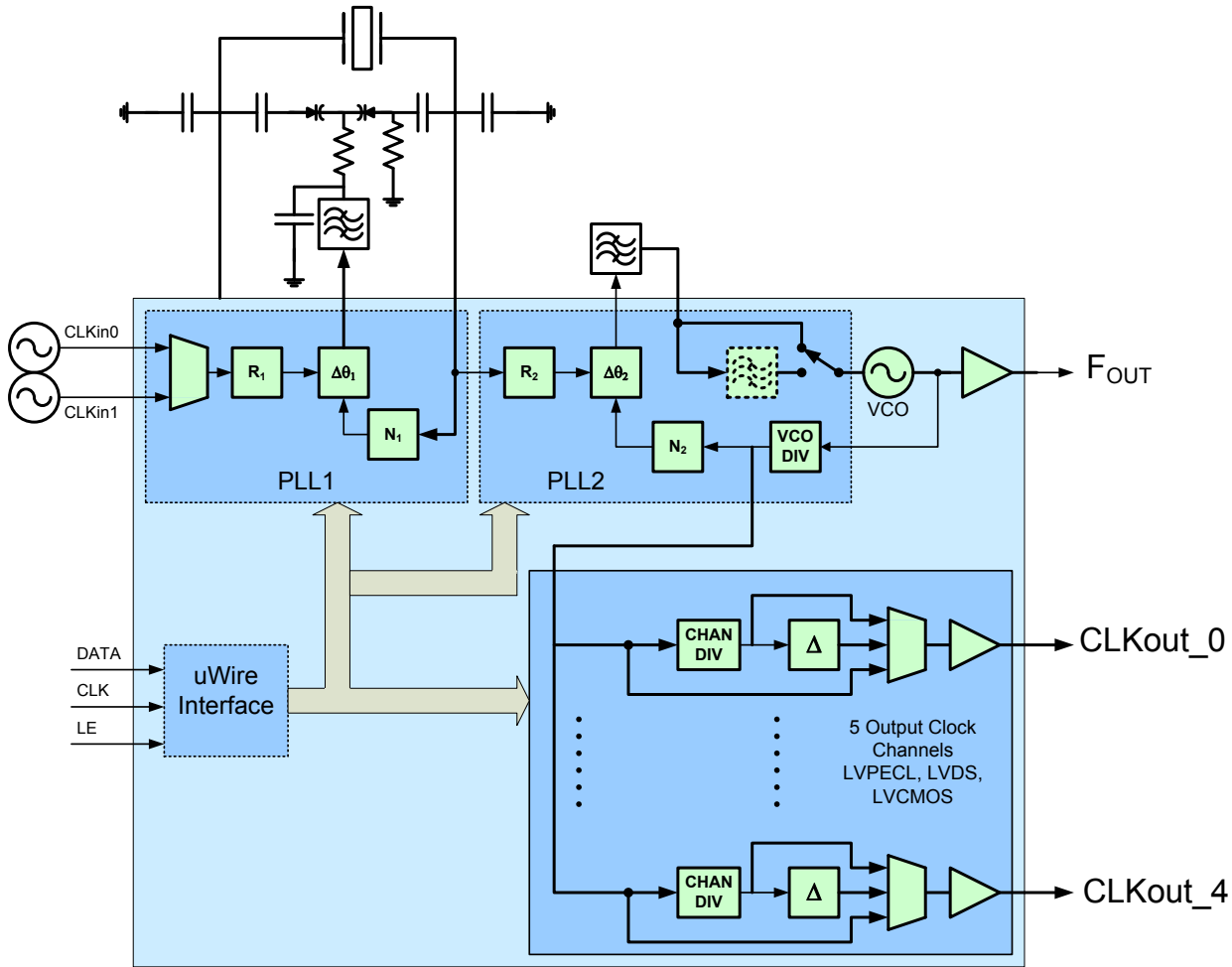

Figure 3. LMK040xx with the XTAL Resonator option and Tuning Circuit

LMK040xxB evaluation boards are configured with a VCXO (NSID = LMK040xxEVAL) or crystal-based oscillator circuit (NSID = LMK040xxEVAL-XO). The VCXO frequency is typically 122.88 MHz. The crystal frequency is typically 12.288 MHz. These evaluation board instructions apply to either configuration. Figure 4 illustrates the oscillator circuit based on a pullable crystal resonator.

Note that it is possible to place a VCXO or crystal on any evaluation board. The user may switch between oscillator types by removing and replacing certain components on the board. Instructions for modifying the board are presented in Appendix .

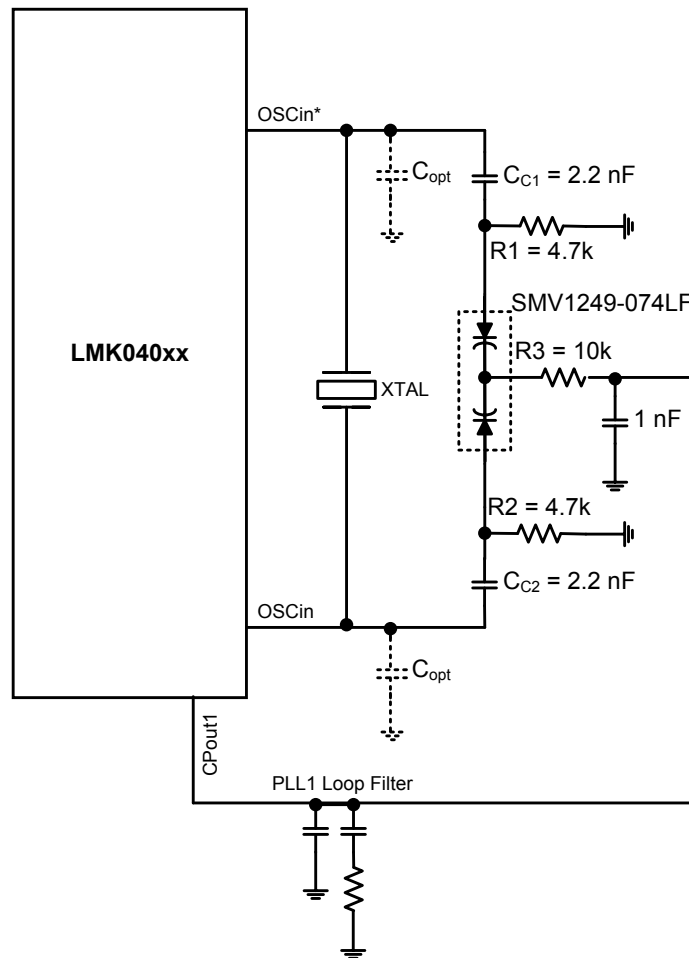
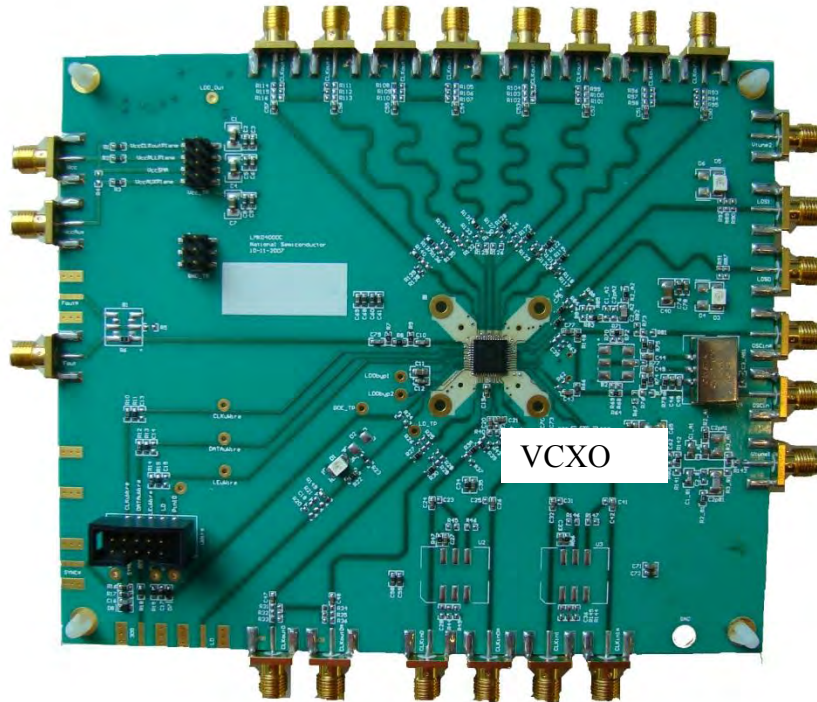

Figure 4. XTAL Oscillator Circuit diagram

Below is the VCXO version of the board.



Below is the board with crystal installed. The surface mount crystal is installed on the bottom side of the board, along with the other components of the oscillator.

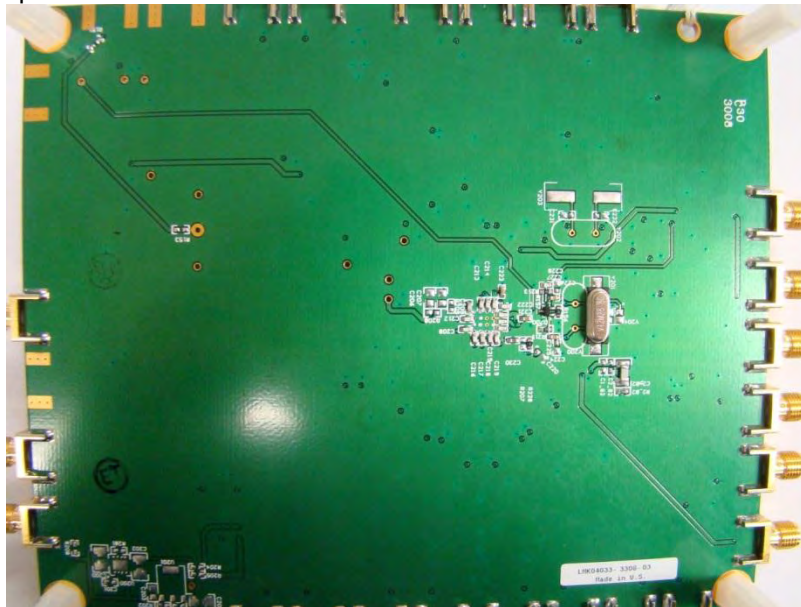

Table below lists the clock output / frequency options for the LMK04000 Family. The second digit indicates VCO frequency, the second to last digit indicates output configuration. The highlighted boards indicate for which parts evaluation boards are available.

Table 1. LMK040xxB Clock Output Configuration

Part Number	CLKout0	CLKout1	CLKout2	CLKout3	CLKout4	VCO Frequency
LMK04000BISQ	LVPECL/ 2VPECL	LVC MOS (2x)	LVC MOS (2x)	LVPECL/ 2VPECL	LVPECL/ 2VPECL	1185 MHz – 1296 MHz
LMK04001BISQ	LVPECL/ 2VPECL	LVC MOS (2x)	LVC MOS (2x)	LVPECL/ 2VPECL	LVPECL/ 2VPECL	1430 MHz – 1570 MHz
LMK04002BISQ	LVPECL/ 2VPECL	LVC MOS (2x)	LVC MOS (2x)	LVPECL/ 2VPECL	LVPECL/ 2VPECL	1566 MHz – 1724 MHz
LMK04011BISQ	LVPECL/ 2VPECL	LVPECL/ 2VPECL	LVPECL/ 2VPECL	LVPECL/ 2VPECL	LVPECL/ 2VPECL	1430 MHz – 1570 MHz
LMK04031BISQ	LVDS	LVPECL/ 2VPECL	LVC MOS (2x)	LVPECL/ 2VPECL	LVDS	1430 MHz – 1570 MHz
LMK04033BISQ	LVDS	LVPECL/ 2VPECL	LVC MOS (2x)	LVPECL/ 2VPECL	LVDS	1840 MHz – 2160 MHz

Note: LVPECL/2VPECL is software programmable.

Evaluation Board Kit Contents

The evaluation board is typically shipped with a parallel port cable that is used to interconnect the board to a PC USB or LPT port, enabling the board to be programmed. The kit may also include one or more BALUN boards. Each BALUN board is configured to accept a differential signal input and provide a single-ended signal output. This enables the differential clock outputs of the LMK040xxB to be connected to test equipment or to drive single-ended circuits. The user should be aware that there is some attenuation of the clock signal when using these boards. Please see also “EVM Software and Communication: Interfacing u-Wire” for more information).

Appendix contains typical frequency response data for the BALUN boards.

NOTE: If the board contains an ADT2-1T BALUN, DC bias on the input signals is blocked at the output. If the board contains an ADTL2-18, DC bias on the input will be passed to the output. This may be unacceptable for some types of test equipment.

PLL Loop Filters and Loop Parameters

In jitter cleaning applications that use a cascaded PLL architecture, the first PLL affectively substitutes the phase noise of a low noise oscillator (VCXO or crystal resonator) for the phase noise of a “dirty” reference clock. The first PLL is typically configured with a narrow loop bandwidth in order to minimize the impact of the reference clock phase noise. The reference clock consequently serves only as a frequency reference rather than a phase reference. If the jitter of the VCXO is superior to that of the reference clock, the loop bandwidth of the second PLL can be made much wider relative to the first PLL.

The loop filters on the LMK040xx evaluation board are setup using this approach. The loop filter for PLL1 has been configured for a narrow loop bandwidth (< 100 Hz), while the loop filter of PLL2 has been configured for a wide loop bandwidth (> 50 kHz). The specific loop bandwidth values depend on the phase noise performance of the oscillator mounted on the board. The following tables contain the parameters for PLL1 and PLL2 for each oscillator option. Texas Instruments Incorporated’s Clock Design Tool can be used to optimize PLL phase noise/jitter for given specifications. See: www.ti.com.

PLL1 and PLL2 Parameters for Crystal Mode operating with a 12.288 MHz XTAL.

XTAL OSC Option PLL 1 Loop Filter			
Phase Margin	61°	K•	100 uA
Loop Bandwidth	10 Hz	Fcomp	1024 kHz
Ref Clk Frequency	122.88 MHz	Output Frequency	12.288 MHz (To PLL 2)
Supply Voltage	3.3 Volts	VCO Gain	1.5 kHz/Volt
Loop Filter Components	C1 = 330 nF	C2 = 10 uF	R2 = 3.9k ohms
XTAL Option PLL 2 Loop Filter			
Phase Margin	66°	K•	1600 uA
Loop Bandwidth	54 kHz	Fcomp	12.288 MHz
Crystal Frequency	12.228 MHz (From PLL1)	Output Frequency	1474.56 MHz

XTAL OSC Option PLL 1 Loop Filter			
Supply Voltage	3.3 Volts	VCO Gain	10 MHz/Volt
Loop Filter Components	C1 = 0	C2 = 6.8 nF	R2 = 2.7k ohms
	C3 = 100 pF	C4 = 110 pF	R3 = 0.6k ohms
			R4 = 0.2k ohms

Note: PLL Loop Bandwidth is a function of $K\phi$, $Kvco$, N as well as loop components. Changing $K\phi$ and N will change the loop bandwidth.

PLL1 and PLL2 Parameters for VCXO Option, 100 MHz.

100 MHz VCXO option PLL 1 Loop Filter			
Phase Margin	50°	K·	100 μ A
Loop Bandwidth	20 Hz	Fcomp	1 MHz
Ref Clk Frequency	10 MHz	Output Frequency	100 MHz (To PLL 2)
Supply Voltage	3.3 Volts	VCO Gain	4 kHz/Volt
Loop Filter Components	C1 = 100 nF	C2 = 680 nF	R2 = 39k ohms
100 MHz VCXO Option PLL 2 Loop Filter			
Phase Margin	79°	K·	3200 μ A
Loop Bandwidth	301 kHz	Fcomp	50 MHz
VCXO Frequency	100 MHz (From PLL1)	Output Frequency	1500 MHz
Supply Voltage	3.3 Volts	VCO Gain	10 MHz/Volt
Loop Filter Components	C1 = 0	C2 = 12 nF	R2 = 1.8 k ohms
	C3 = 0	C4 = 10 pF	R3 = 0.6k ohms
			R4 = 0.2k ohms

Note: PLL Loop Bandwidth is a function of $K\phi$, $Kvco$, N as well as loop components. Changing $K\phi$ and N will change the loop bandwidth.

PLL1 and PLL2 Parameters for VCXO Option, 61.44 MHz

61.44 MHz VCXO option PLL 1 Loop Filter			
Phase Margin	50°	K·	100 μ A
Loop Bandwidth	20 Hz	Fcomp	1.024 MHz
Ref Clk Frequency	122.88 MHz	Output Frequency	61.44 MHz (To PLL 2)
Supply Voltage	3.3 Volts	VCO Gain	2.5 kHz/Volt
Loop Filter Components	C1 = 100 nF	C2 = 680 nF	R2 = 39k ohms

61.44 MHz VCXO PLL 2 Loop Filter			
Phase Margin	74°	K_φ	1600 uA
Loop Bandwidth	185 kHz	F_{comp}	61.44 MHz
VCXO Frequency	61.44MHz (From PLL1)	Output Frequency	1474.56 MHz
Supply Voltage	3.3 Volts	VCO Gain	10 MHz/Volt
Loop Filter Components	C1 = 0	C2 = 12 nF	R2 = 1.8 k ohms
C3 = 50 pF	C4 = 10 pF	R3 = 0.6k ohms	R4 = 0.2k ohms

Note: PLL Loop Bandwidth is a function of K_{ϕ} , K_{vco} , N as well as loop components. Changing K_{ϕ} and N will change the loop bandwidth.

Table 2. LMK040XX Eval Board and CodeLoader *.mac File Cross Reference

LMK040XX Device family	VCXO / XTAL	VCXO/XTAL Frequency (MHz)	PLL1 Reference clock (MHz)	Configuration file (*.mac)
LMK040X1	VCXO	100	10	Std_LMK040X1_10MHZ_ref_100MHZ_VCXO.mac
LMK040X1	VCXO	61.44	122.88	Std_LMK040X1_122_88MHZ_ref_61_44MHZ_VCXO.mac
LMK040X1	Crystal	12.288	122.88	Std_LMK040X1_XTAL_1X_122_88MHZ_Ref.mac
LMK040X1	Crystal	12.288	122.88	Std_LMK040X1_XTAL_2X_122_88MHZ_Ref.mac
LMK040X3	VCXO	61.44	122.88	Std_LMK040X3_122_88MHZ_ref_61_44MHZ_VCXO.mac

Evaluation Board Notes

1. F_{out} is AC-coupled. A 3 dB pad is installed between the F_{out} pin and the SMA connector. The nominal output level will be -1 dBm.
2. All clock outputs are AC-coupled.
3. All LVPECL/2VPECL clock outputs are terminated to GND with a 120 ohm resistor, one on each output pin of the pair.

Evaluation Board Inputs/Outputs

The following table contains descriptions of the various inputs and outputs for the evaluation board.

Table 3. LMK040XX Evaluation Board I/O

Connector Name	Input/Output	Description
CLKout0 / CLKout0*, CLKout1 / CLKout1*, CLKout2 / CLKout2*, CLKout3 / CLKout3*, CLKout4 / CLKout4*	Output	Differential clock output pairs. See Table 1 for format depending on part number. If LVCMOS, each output can be independently configured (non-inverted, inverted, tri-state, and LOW). All clock outputs are AC-coupled.

Connector Name	Input/Output	Description
Fout	Output	When enabled, buffered VCO output. AC-coupled. The default configuration on the board contains a 3-dB attenuator on the Fout signal.
Vcc	Input	DC power supply for the LMK040XX device. Note: The LMK040XX family contains internal voltage regulators for the VCO, PLL and related circuitry. The clock outputs do not have an internal regulator. A clean power supply is required for best performance.
VccAux	Input	DC power supply for on-board VCXOs, reference oscillators, and Global Output Enable (GOE). Notes: <ol style="list-style-type: none"> Vcc and VccAux power buses may be interconnected by placing a jumper on the VCC_TP header. VCOs and VCXOs are sensitive to power supply noise. If the board is configured with an on-board VCXO or on-board reference clock, best performance will be achieved if a clean power supply is connected to VccAux.
CLKin0/CLKin0*, CLKin1/CLKin1*	Input	Reference clock inputs for PLL1. The default board configuration is setup for a single-ended reference source at CLKin0* (CLKin0 pin is AC-coupled to ground). The format of the clock input buffer is programmable in CodeLoader on the Bits/Pins tab, and may be either bi-polar junction mode or MOS mode. The input power level for an AC-coupled differential input should be between -2 dBm and +13 dBm for bipolar mode and between +4 dBm and +13 dBm for MOS mode. If either clock input is driven using a single-ended signal, the signal level should be between -8 dBm and +8 dBm for bipolar mode, and between -2 dBm and +10 dBm in MOS mode. If a DC-coupled clock is used to drive either of the inputs, the peak voltage level must be at least 2 volts and the minimum voltage no greater than 0.4 volts. By default CLKin0 is the active input in either of the auto-switching modes (<i>CLKin0 non-revertive</i> , <i>CLKin0 revertive</i>). When loss of CLKin0 is detected, the device automatically switches to CLKin1 if an active reference clock is attached. See data sheet for further explanation.
LOS0, LOS1	Output	Loss-of-Signal indicator (CMOS) for CLKin0/0* and CLKin1/1*. See data sheet for further explanation of the LOS pins.
OSCin/OSCin*	Input	If the evaluation board is not configured with an on-board VCXO module or on-board crystal-based VCXO, an external VCXO may be attached to the OSCin/OSCin* SMA connectors. Either a differential or single-ended device may be used. If a single-end device is used, OSCin* should be tied to GND through a capacitor that matches the AC-coupling capacitor value used for the OSCin pin. Pads for this capacitor are located close to the OSCin* pin. This capacitor is not placed for either of the default configurations of the board. See the LMK04000 data sheet for OSCin port signal specifications.
Vtune1	Output	Tuning voltage output from the loop filter for PLL1. This control voltage should be connected to the voltage control pin if an external VCXO is used. Note: Resistor R143 must be populated with a zero ohm resistor to control an off-board VCXO.
Vtune2	Output	Available to monitor the tuning voltage for the internal VCO. Resistor R84 must be populated with a zero ohm resistor.
uWire	Input/Output	10-pin header programming interface for the board. CLK, DATA and LE signal lines. Each of these signals can be monitored through test points on the board.

Connector Name	Input/Output	Description
LD_TP	Output	Test point attached to the LD pin of the device. The LD pin is attached to a multiplexer inside the device and may be programmed with a variety of internal signals for monitoring internal device functions and troubleshooting. See data sheet for further explanation. The <i>lock detect</i> signal is accessible through this pin.

Typical Phase Noise Performance

The following table lists the test conditions used for the phase noise measurements for the crystal oscillator option:

Table 4 . LMK040XX test conditions, XTAL Oscillator Option

Parameter	Value
PLL1 Reference clock input	CLKin0*, single-ended, CLKin0 AC-coupled to GND
PLL1 Reference Clock frequency	122.88 MHz
PLL1 Phase detector frequency	1024 kHz
PLL1 Charge Pump Gain	100 μ A
VCXO frequency	12.288 MHz, Ecliptek ECX-6465
PLL2 phase detector frequency	12.288 MHz
PLL2 Charge Pump Gain	3200 μ A
PLL2 REF2X mode	disabled

NOTE: All jitter measurements are for a 100 Hz to 20 MHz integration bandwidth.

The following plot illustrates the phase noise measured at F_{out} , CLKout0 (LVDS), CLKout1 (LVPECL), and CLKout2 (LVCMOS) using the XTAL oscillator option.

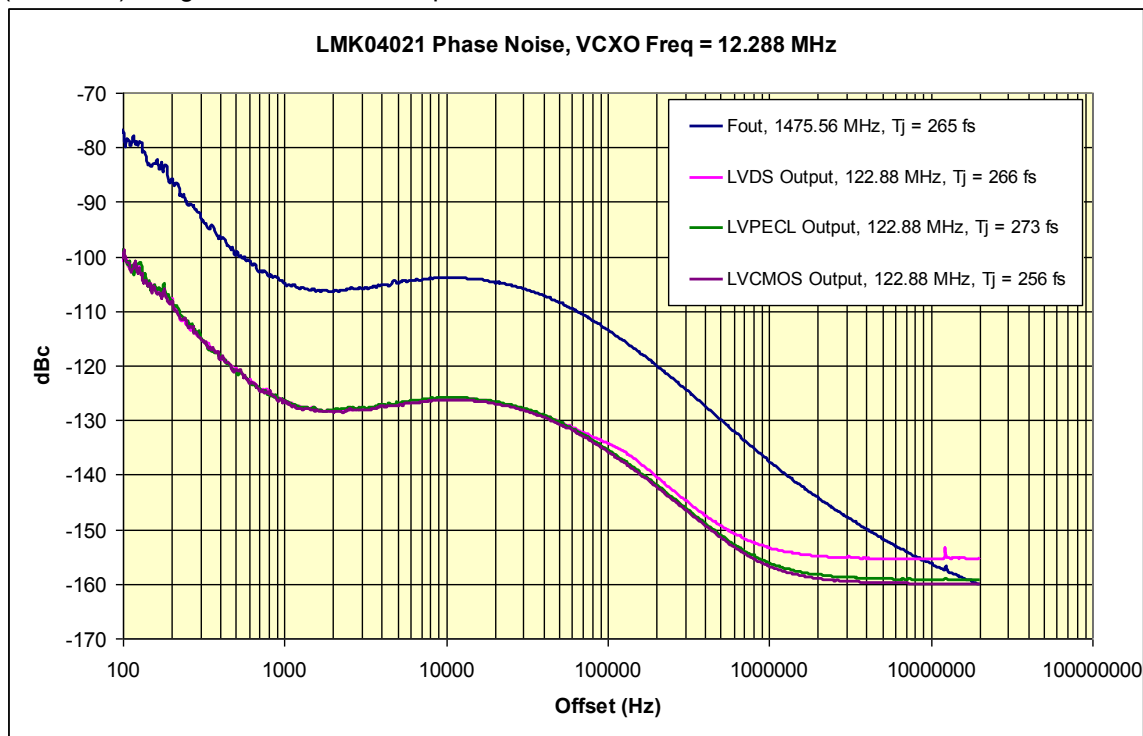

Figure 5. Typical Phase Noise Performance at F_{out} , $F_{vco} = 1474.56$ MHz, $F_{comp2} = 12.288$ MHz. XTAL Resonator option. Jitter metrics are for an integration bandwidth of 100 Hz to 20 MHz.

The phase noise and jitter performance at the clock outputs of the LMK040XX is strongly dependent on the phase noise characteristics of the VCXO or crystal driving the OSCin port.

The next sets of phase noise plots represent typical performance achieved using modular VCXO packages with PLL1. The first set of plots contains the VCXO phase noise plots for the 100 MHz VCXO and the 61.44 MHz VCXO.

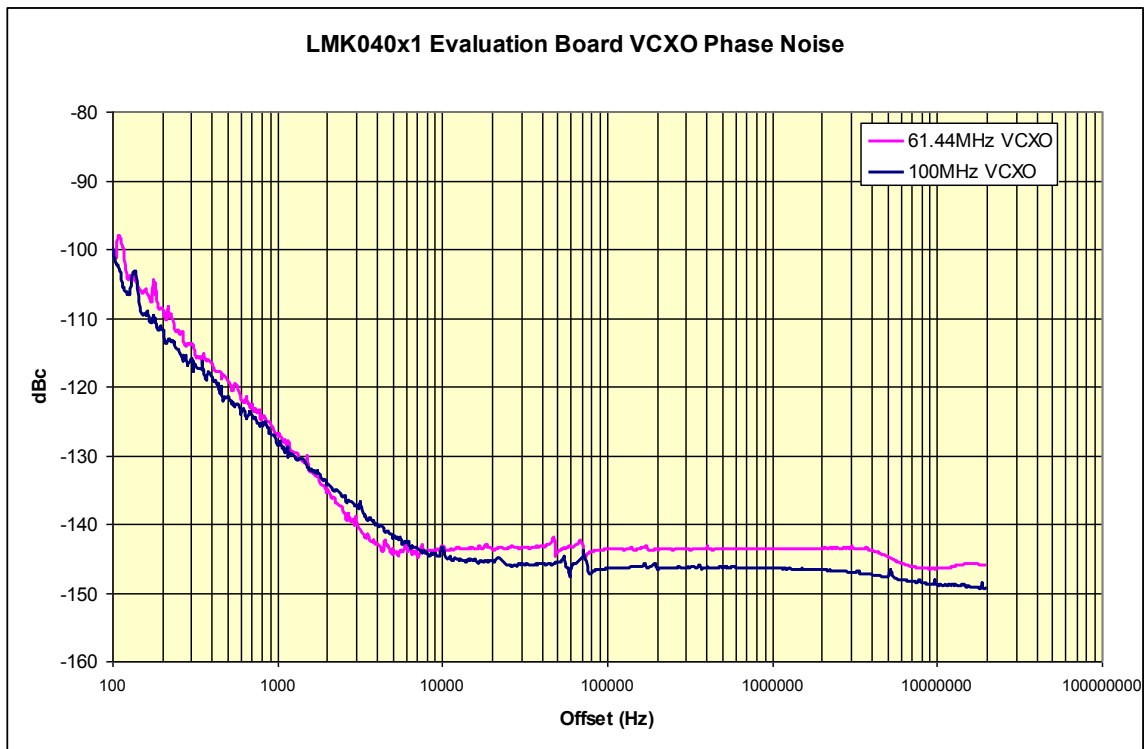

Figure 6. LMK040X1 Evaluation Board, typical VCXO Phase Noise, 100 MHz and 61.44 MHz VCXOs.

The following table lists the test conditions used for the phase noise measurements based upon the VCXO option, 100 MHz:

Table 5. LMK040XX test conditions, 100 MHz VCXO Option, LMK04021

Parameter	Value
PLL1 Reference clock input	CLKin0, single-ended, CLKin0* AC-coupled to GND
PLL1 Reference Clock frequency	100 MHz
PLL1 Phase detector frequency	1000 kHz
PLL1 Charge Pump Gain	100 μ A
VCXO frequency	100 MHz, Crystek CVPD-920
PLL2 phase detector frequency	50 MHz
PLL2 REF2X mode	disabled
PLL2 Charge Pump Gain	3200 μ A

The following plot illustrates the phase noise performance of the LMK040XX using the VCXO option. The VCXO represented in these plots is a Crystek CVPD-920-100MHz LVPECL model.

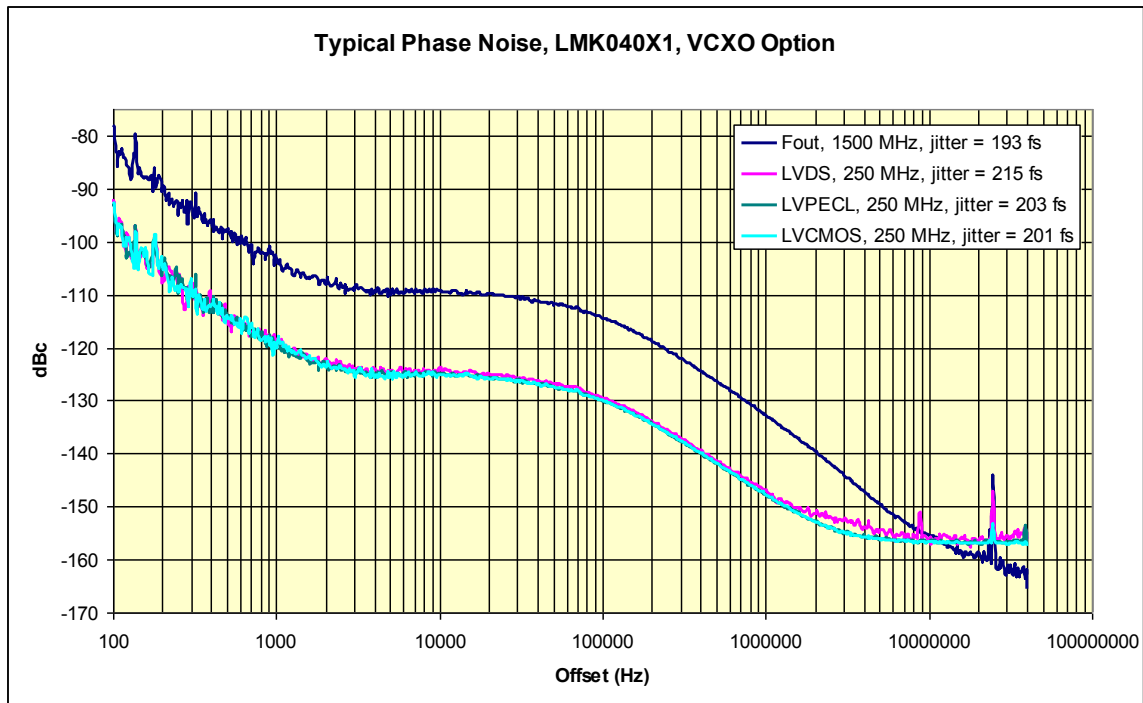

Figure 7. Typical Phase Noise, LMK040X1, VCXO Option (100 MHz). Jitter metrics are for an integration bandwidth of 100 Hz to 20 MHz.

The following plot illustrates the phase noise performance of the LMK040XX using the VCXO option. In this case, the VCXO is a Crystek CVPD-920-61.44 MHz LVPECL model.

Table 6. Test Conditions for Phase Noise Measurements, 61.44 VCXO option, LMK04020

Parameter	Value
PLL1 Reference clock input	CLKin0*, single-ended, CLKin0 AC-coupled to GND
PLL1 Reference Clock frequency	61.44 MHz
PLL1 Phase detector frequency	1024 MHz
PLL1 Charge Pump Gain	100 μ A
VCXO frequency	61.44 MHz, Crystek CVPD-920
PLL2 phase detector frequency	61.44 MHz
PLL2 REF2X mode	disabled
PLL2 Charge Pump Gain	1600 μ A

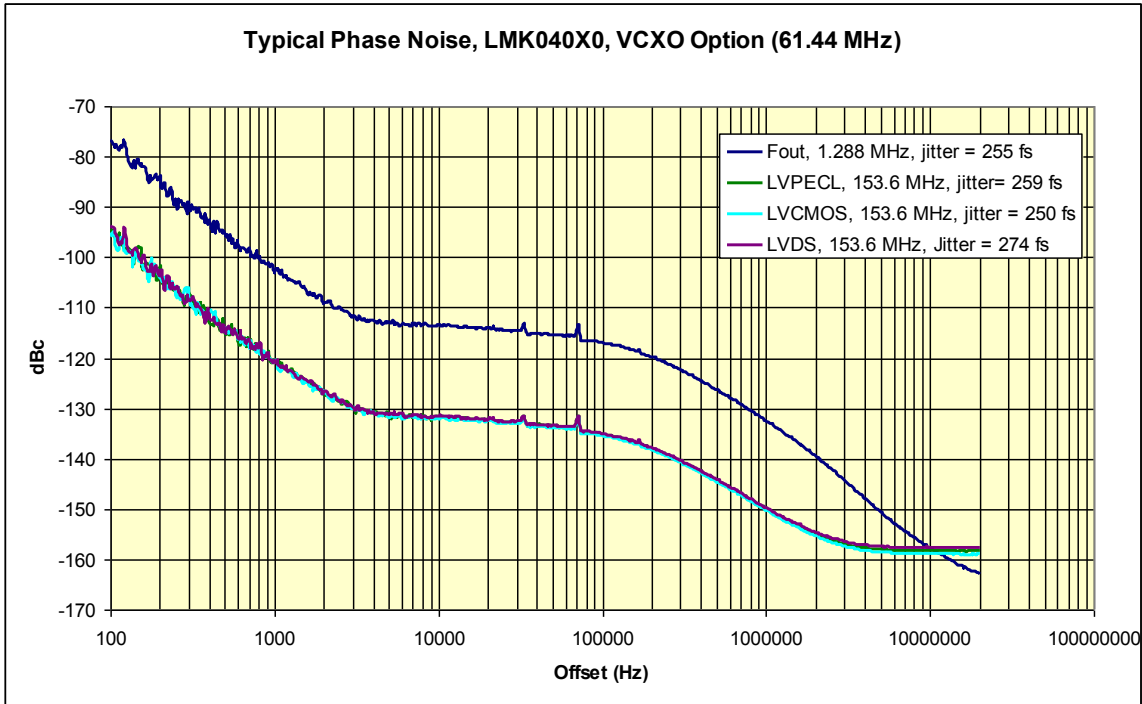
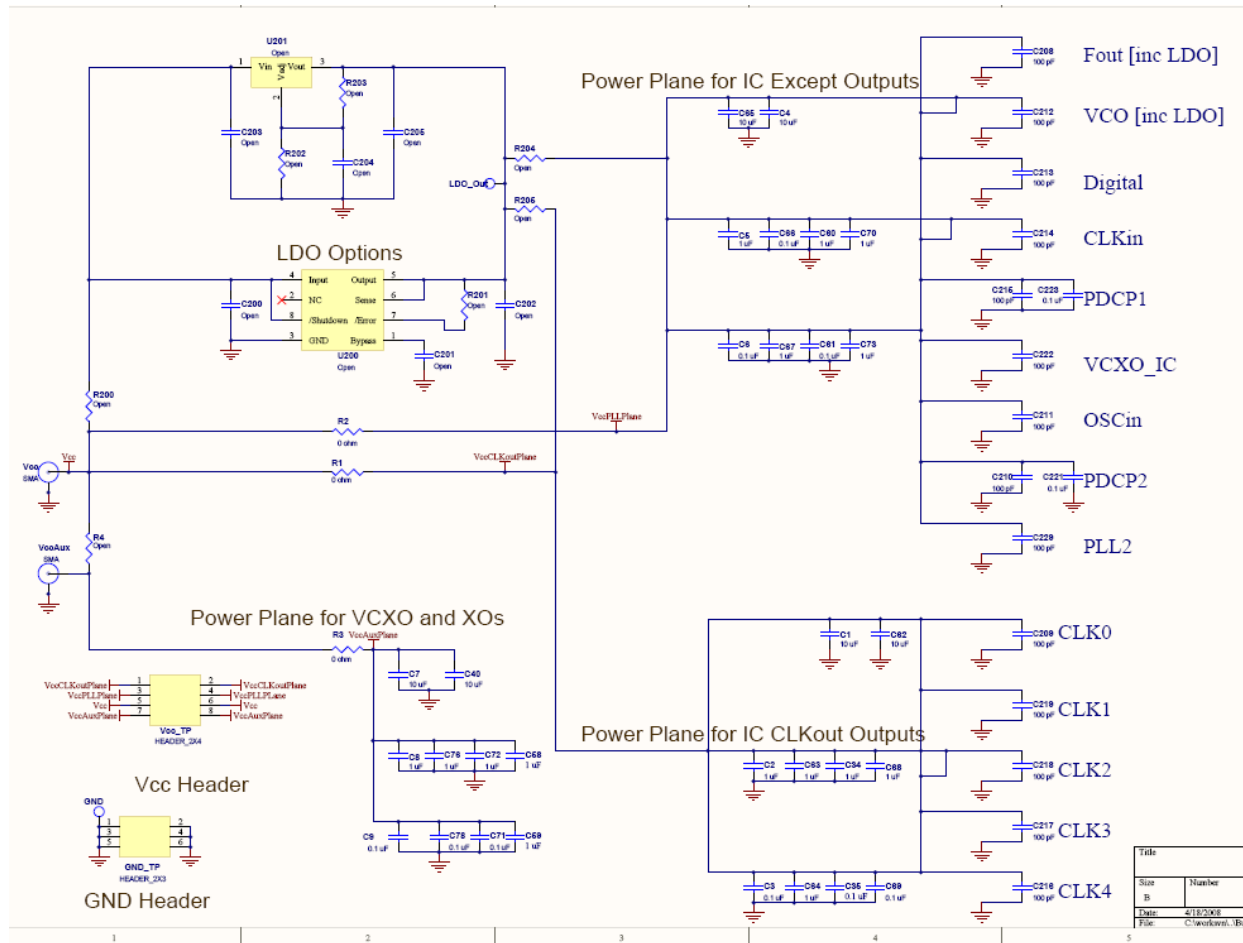
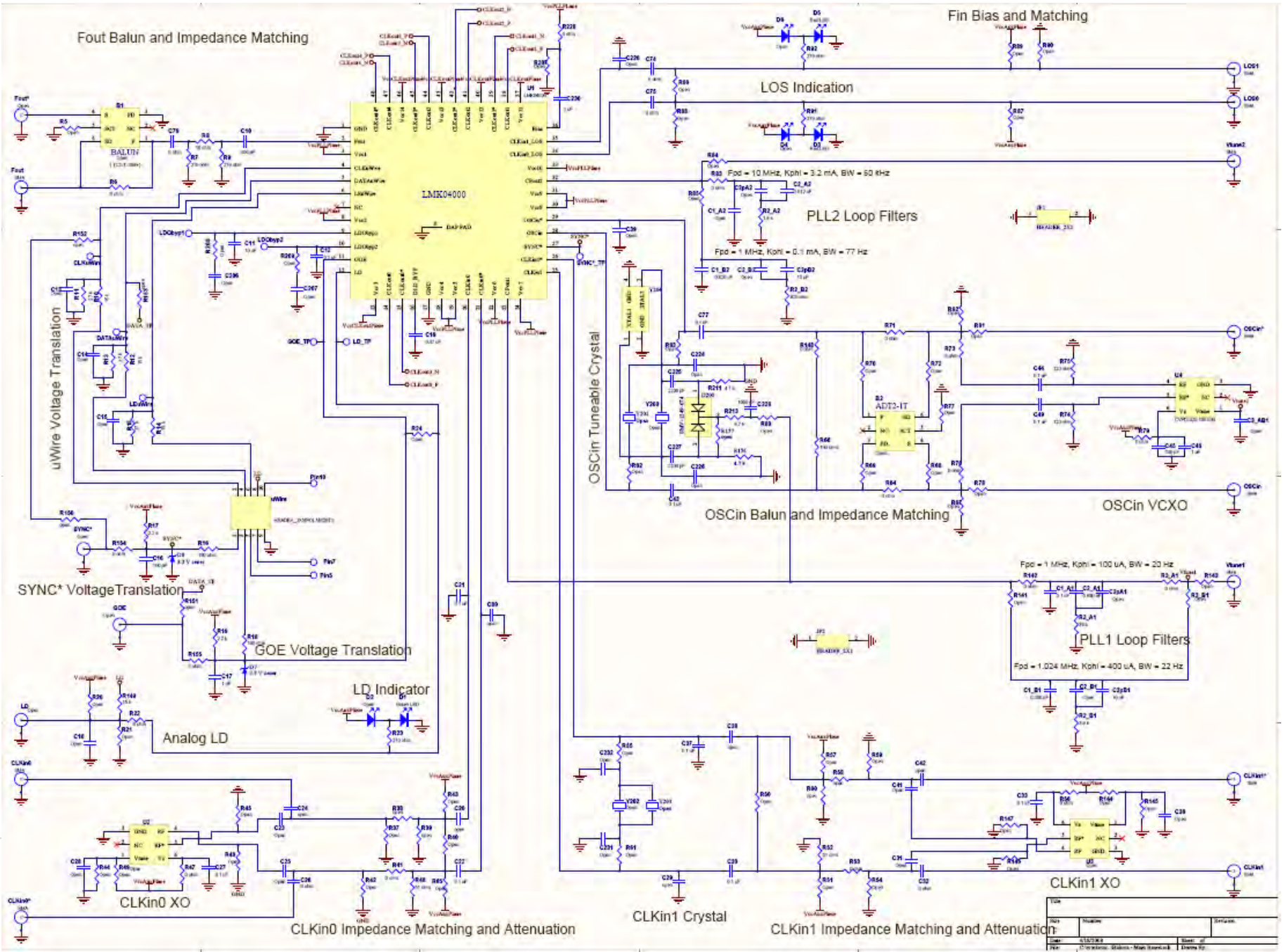

Figure 8. Typical Phase noise, LMK04020, VCXO Option (61.44 MHz). Jitter metrics are for an integration bandwidth of 100 Hz to 20 MHz.

Appendix A: Schematics



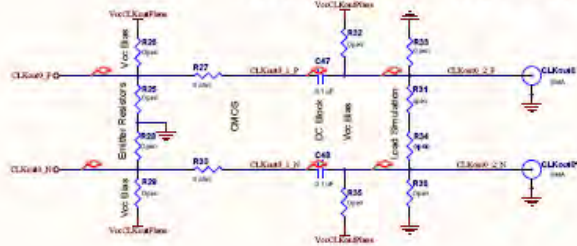

Rev	Number	Stratum
1	01/01/01	1
2	01/01/01	1

CLKout0 (LVPECL/2VPECL or LVDS)

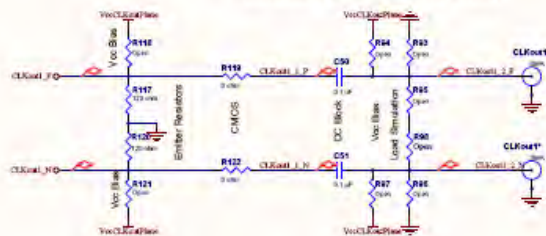
CLKout4 (LVPECL/2VPECL or LVDS)

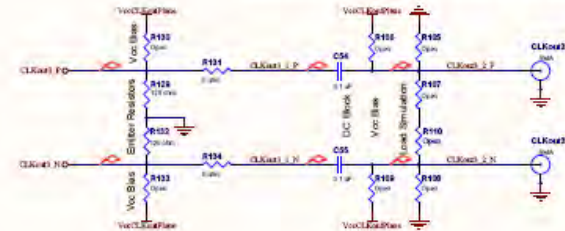
CLKout1 (LVPECL/2VPECL)

CLKout2 (LVPECL/2VPECL or LVCMOS)

CLKout3 (LVPECL/2VPECL or LVCMOS)

Appendix B: Board Layers Stackup

Layers of the 6 layer evaluation board include:

Blue is dielectrics

- Top layer for high priority high frequency signals
 - 1 oz CU
- RO4003 Dielectric, **16 mils**
- Ground plane
- FR4, **2.5 mils** thick.
- Power plane #1 – VccCLK
- FR4, xx mils
- middle ground plane
- FR4, xx mils
- VccPLL, VccAux
- FR4, xx mils
- Bottom layer copper clad for thermal relief

Top to bottom layer order:

LMK04000.GTL	(1)
LMK04000.GP1	(2) gnd
LMK04000.GP2	(3) vcc
LMK04000.GP3	(4) gnd
LMK04000.G1	(5) vcc
LMK04000.GBL	(6)

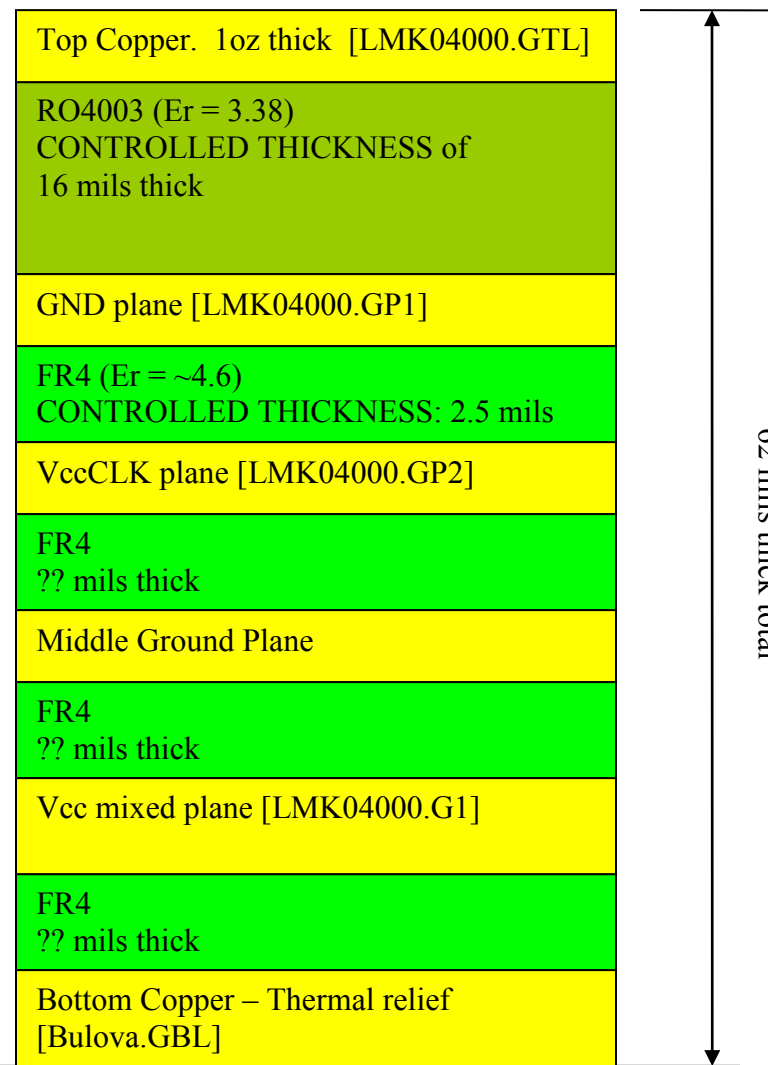

Appendix C: Bill of Materials

Part	Manufacturer	Part Number	Qty	Identifier
Capacitors				
100 pF	Kemet	C0603C101J5GAC	4	C10, C16, C45, C79
100 pF	Kemet	C0603C101J5GAC	14	C208, C209, C210, C211, C212, C213, C214, C215, C216, C217, C218, C219, C222, C229
1 nF	Kemet	C0603C102J5GAC	1	C1_B1
1 nF	Kemet	C0603C102J5GAC	1	C228
2.2 nF	Kemet	C0603C222K5RAC	2	C225, C227
5.6 nF	Kemet	C1210C562J1GAC	1	C2pB1
12 nF	Kemet	ECH-U01123JX5	1	C2_A2
0.1 uF	Kemet	C0603C104J3RAC	10	C3, C6, C9, C12, C35, C61, C66, C69, C71, C78
0.1 uF	Kemet	C0603C104J3RAC	27	C19, C20, C21, C24, C26, C27, C30, C32, C33, C37, C42, C43, C44, C47, C48, C49, C50, C51, C52, C53, C54, C55, C56, C57, C77, C221, C223
100 nF	Kemet	C0603C104J3RAC	1	C1_A1
680 nF	Kemet	C0603C684K8PAC	1	C2_A1
820 nF	Kemet	C0603C824K8PAC	1	C1_B2
1 uF	Kemet	C0603C105K8VAC	17	C2, C5, C8, C17, C34, C46, C58, C59, C60, C63, C64, C67, C68, C70, C72, C73, C76
1 uF	Kemet	C0603C105K8VAC	1	C230
10 uF	Kemet	C0805C106K9PAC	6	C1, C2pB2, C4, C7, C62, C65
10 uF	Kemet	C0805C106K9PAC	1	C11
10 uF	Kemet	C0805C106K9PAC	1	C40
Resistors				
0 ohm	Vishay	CRCW0603000ZRT1	33	C74, C75, R27, R30, R38, R41, R47, R53, R56, R64, R71, R119, R122, R125, R128, R131, R134, R137, R140, R148, R214, R215, R216, R218, R219, R220, R221, R222, R224, R225, R226, R227, R228
0 ohm	Vishay	CRCW0603000ZRT1	13	R1, R2, R3, R3_A1, R22, R73, R76, R79, R83, R142,

				R212, R217, R223
0 ohm	Yageo	RC0805JR-070RL	1	R6
18 ohm	Vishay	CRCW0603180JRT1	1	R8
51 ohm	Vishay/Dale	CRCW060351R0JNEA	2	R39, R52
100 ohm	Vishay	CRCW0603101JRT1	1	R66
120 ohm	Vishay/Dale	CRCW0603120RJNEA	4	R74, R75, R117, R120
180 ohm	Vishay	CRCW0603181JRT1	2	R16, R18
270 ohm	Vishay	CRCW0603271JRT1	2	R7, R9
820 ohm	Vishay	CRCW0603821JRT1	1	R2_B2
1.8 k	Vishay/Dale	CRCW06031K80JNEA	1	R2_A2
2.2 k	Vishay/Dale	CRCW06032K20JNEA	2	R17, R19
15 k	Vishay	CRCW0603153JRT1	4	R10, R12, R14, R149
27 k	Vishay	CRCW0603273JRT1	3	R11, R13, R15
39 k	Vishay/Dale	CRCW060339K0JNEA	1	R2_A1
47 k	Vishay/Dale	CRCW060347K0JNEA	2	R211, R213
390 k	Vishay/Dale	CRCW0603390KJNEA	1	R2_B1
Other				
SMV1249	Skyworks	SMV1249-074LF	1	D200
3.3 V zener	Comchip	CZRU52C3V3	2	D7, D8
SMA_FRAME	Printed Circuits Corp.	PCB	1	F1
HEADER_2X3	Comm Con Connectors	HTSM3203-6G2	1	GND_TP
HEADER_2X4	Comm Con Connectors	HTSM3203-8G2	1	Vcc_TP
HEADER_2X5 (POLARIZED)	FCI Electronics	52601-S10-8	1	uWire
Green LED	Lumex	SML-LX2832GC-TR	1	D1
Red LED	Lumex	SML-LX2832IC-TR	2	D3, D5
SMA	Johnson Components	142-0701-851	23	CLKin0, CLKin0*, CLKin1, CLKin1*, CLKout0, CLKout0*, CLKout1, CLKout1*, CLKout2, CLKout2*, CLKout3, CLKout3*, CLKout4, CLKout4*, Fout, LOS0, LOS1, OSCin, OSCin*, Vcc, VccAux, Vtune1, Vtune2
CVPD-920-100.000	Crystek	CVPD-920-100.000	1	U4
0.875" Standoffs	SPC Technology	SPCS-14	4	Standoffs in the four corners (insert from bottom)

Open				
Open	-	603	45	C1_A2, C2_B1, C2_B2, C2pA2, C3_AB1, C13, C14, C15, C18, C28, C36, C201, C204, C220, C224, C226, C231, C232, R3_B1, R4, R5, R20, R21, R23, R24, R44, R49, R78, R80, R81, R84, R85, R141, R143, R144, R145, R200, R201, R202, R203, R204, R205, R206, R208, R210
Open	-	Open	93	C22, C23, C25, C29, C31, C38, C39, C41, R25, R26, R28, R29, R31, R32, R33, R34, R35, R36, R37, R40, R42, R43, R45, R46, R48, R50, R51, R54, R55, R57, R58, R59, R60, R61, R62, R63, R65, R67, R68, R69, R70, R72, R77, R82, R86, R87, R88, R89, R90, R91, R92, R93, R94, R95, R96, R97, R98, R99, R100, R101, R102, R103, R104, R105, R106, R107, R108, R109, R110, R111, R112, R113, R114, R115, R116, R118, R121, R123, R124, R126, R127, R129, R130, R132, R133, R135, R136, R138, R139, R146, R147, R207, R209
Open	-	805	3	C203, C206, C207
Open	-	Open	4	C2pA1, C200, C202, C205
Open	-	Open	1	B2
Open	-	Open	1	B1
Open	-	Open	2	Y200, Y202
Open	-	Open	3	D2, D4, D6
Open	-	Open	1	U200
Open	-	Open	2	Y201, Y203
Open	-	Open	5	Fout*, GOE, LD, SYNC*, VinLDOByp
Open	-	Open	1	U201
Open	-	Open	2	U1, U2, U3

Appendix D: Typical BALUN Board Frequency Response

The following figure illustrates the typical frequency response of BALUN using either of the Mini-Circuits models listed.

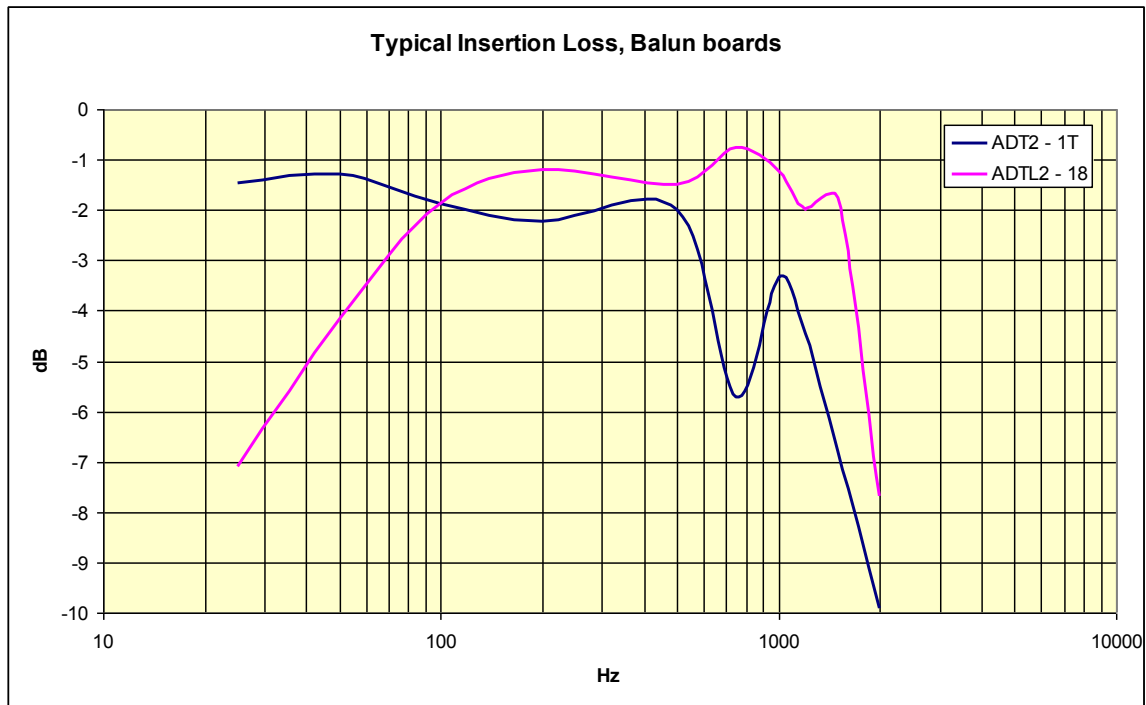

Figure 9. Typical BALUN Frequency Response

Appendix E: Changing Active On-board Oscillator for PLL1

Changing from Crystal Resonator to VCXO

If the board has been setup to use the crystal-based oscillator with PLL1, the crystal may be disabled and the VCXO enabled as described on the following pages:

1. Install a zero Ohm resistor in R79 (near the VCXO)

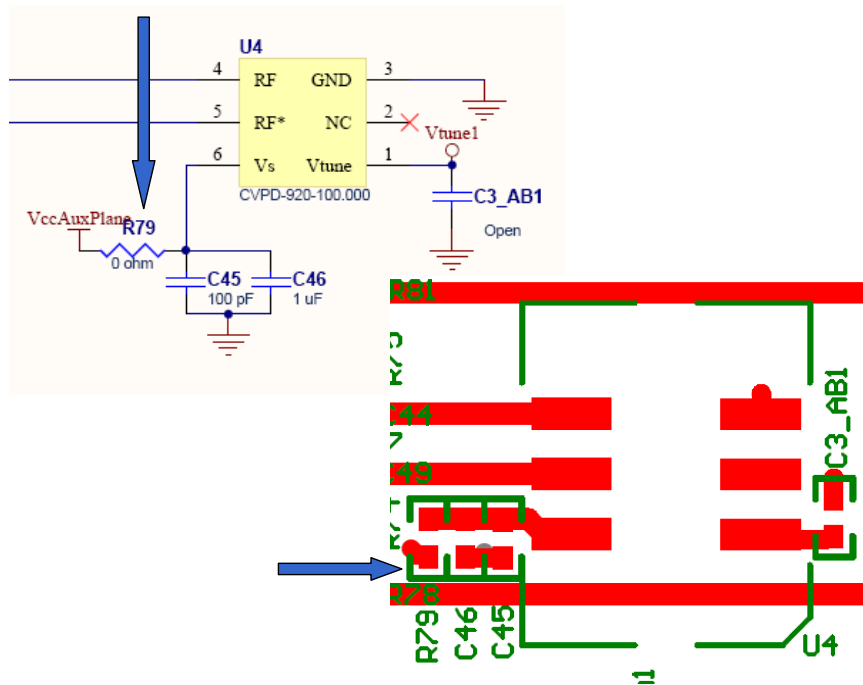

2. Remove resistors R62 and R63 and install 0.1 uF capacitors in C43 and C77.

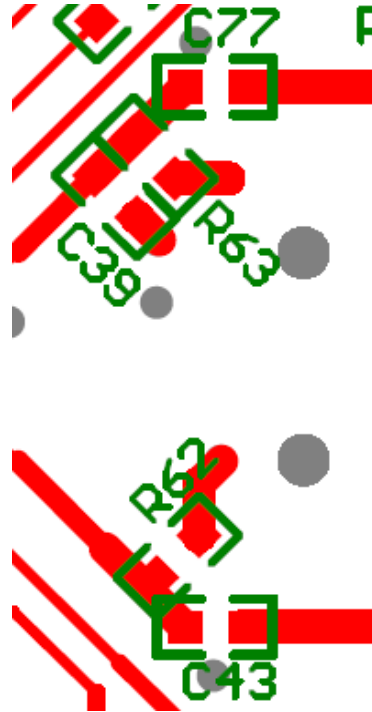
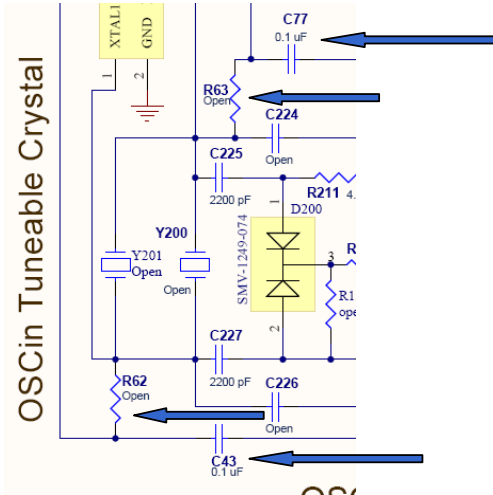

3. Remove resistors R141 and R80. Install a zero Ohm resistor in R142

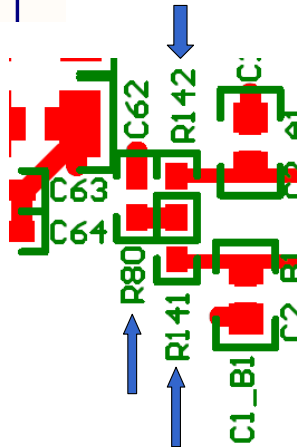
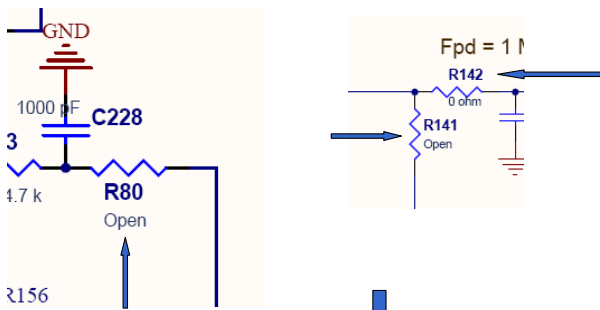

4. Install a 0 Ohm resistor in R83 and remove the 0 Ohm resistor in R85

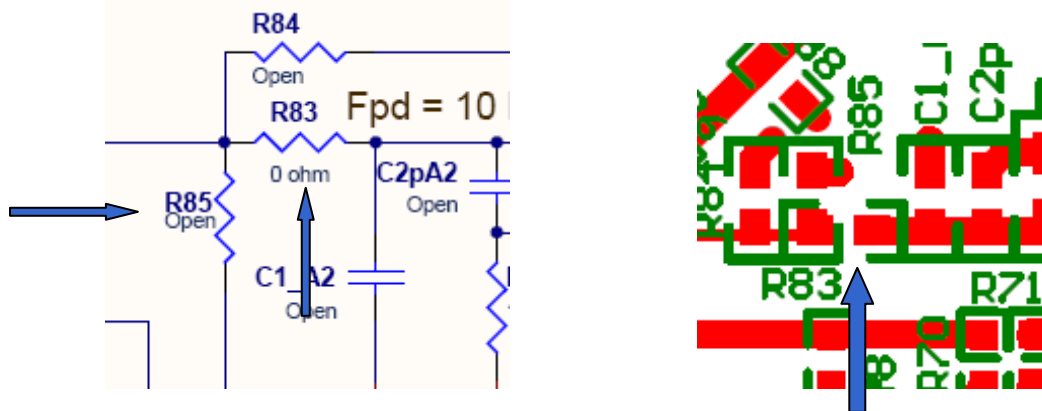

5. Power to the VCXO is provided by placing a jumper on the Vcc_TP header across the traces labeled “VccSMA” and “VccAUXPlane”.

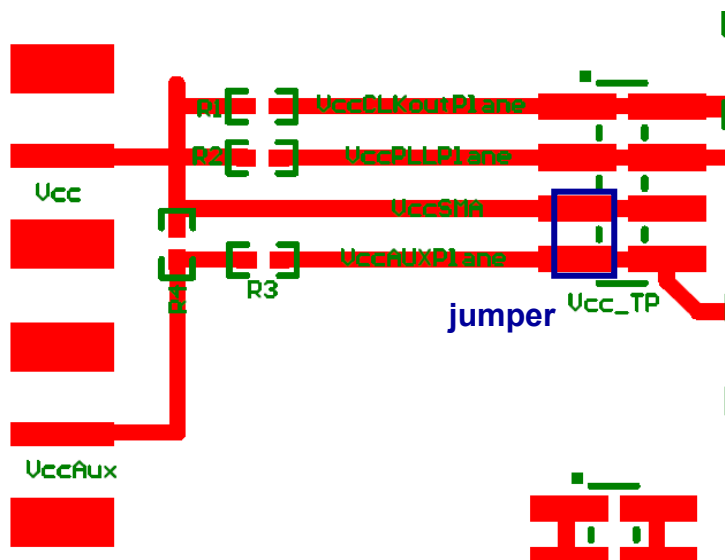

Changing from VCXO to Crystal Resonator

If the board has been setup to use the VCXO for PLL1, the VCXO may be disabled and the crystal enabled as described on the following pages:

1. Remove the zero Ohm resistor R79 (near the VCXO)

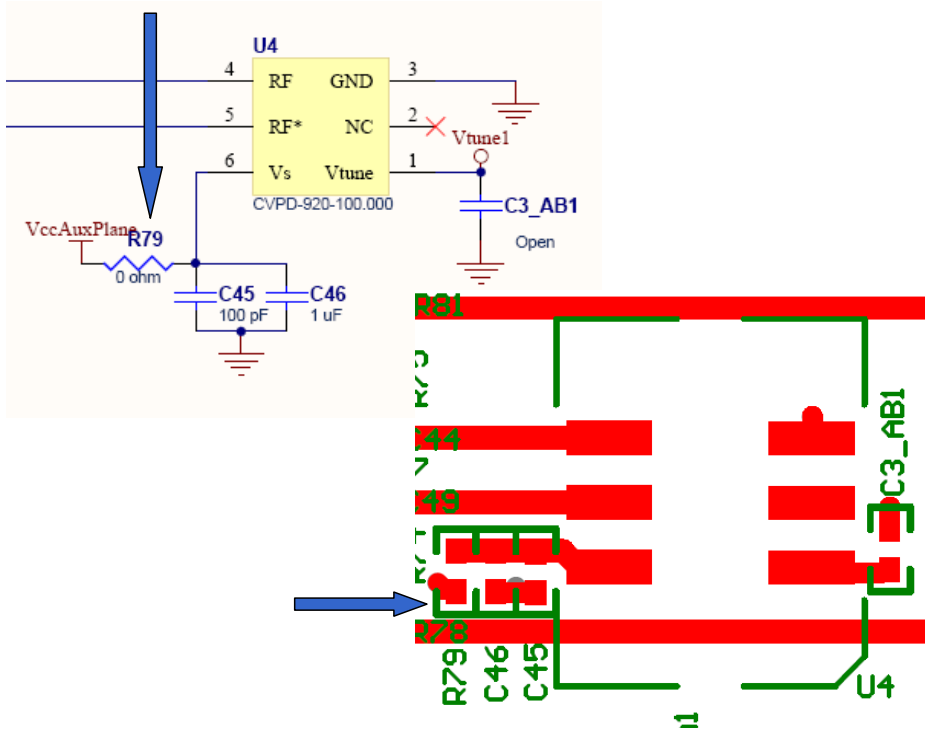

2. Install 0 Ohm resistors R62 and R63 and remove the 0.1 uF capacitors in C43 and C77.

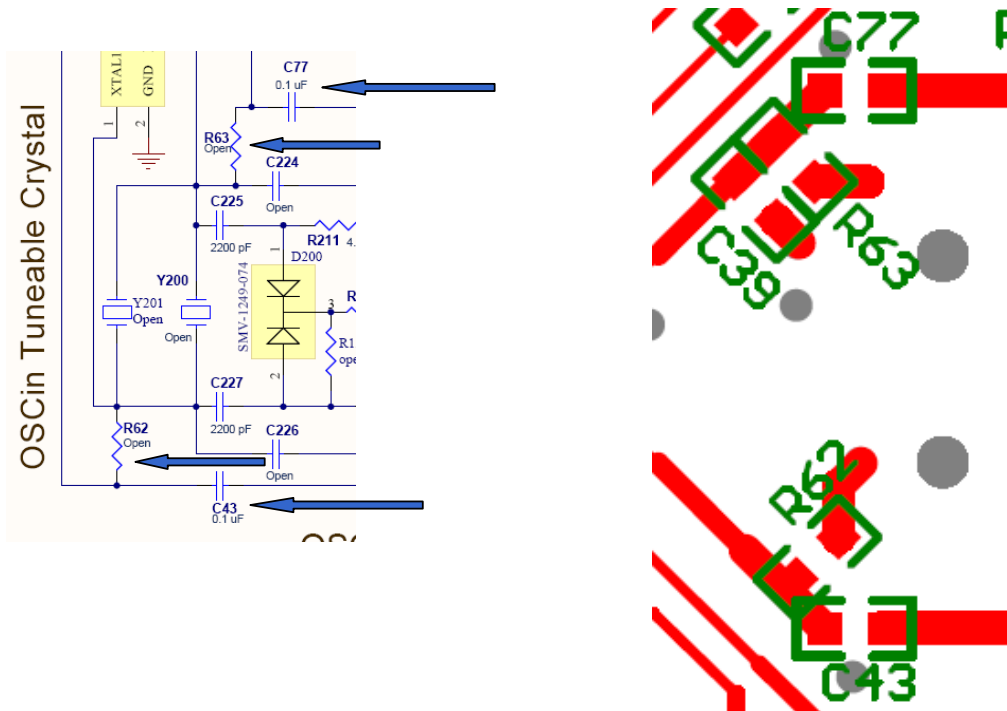

3. Install a 0 Ohm resistor at R141 and R80. Remove the zero Ohm resistor in R142

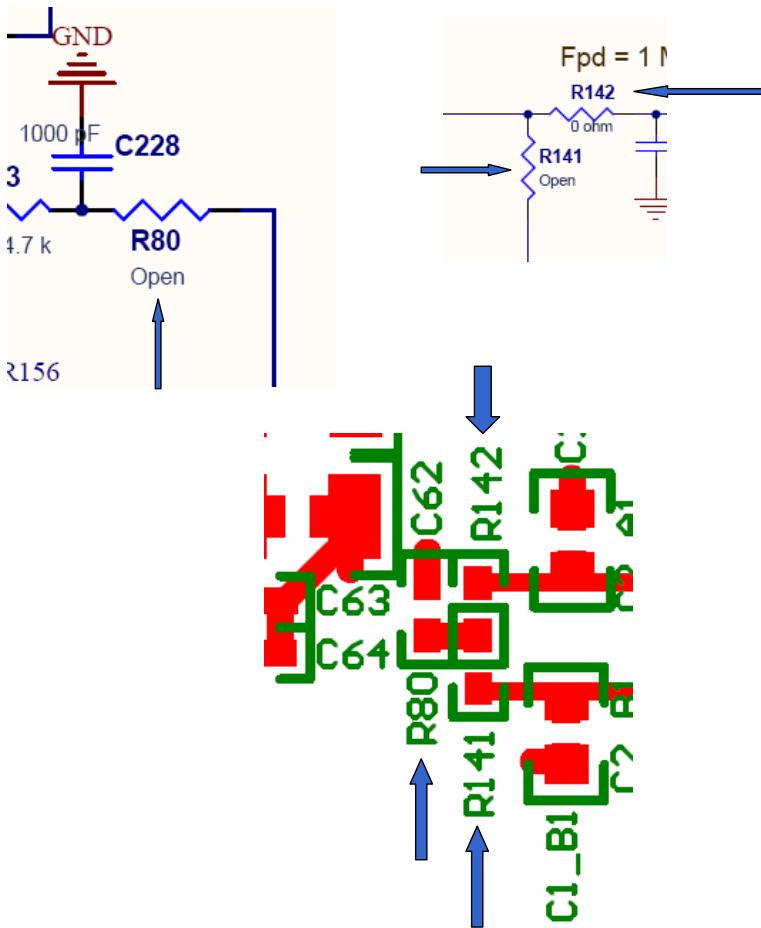

4. Remove the 0 Ohm resistor installed in R83 and install a 0 Ohm resistor in R85.

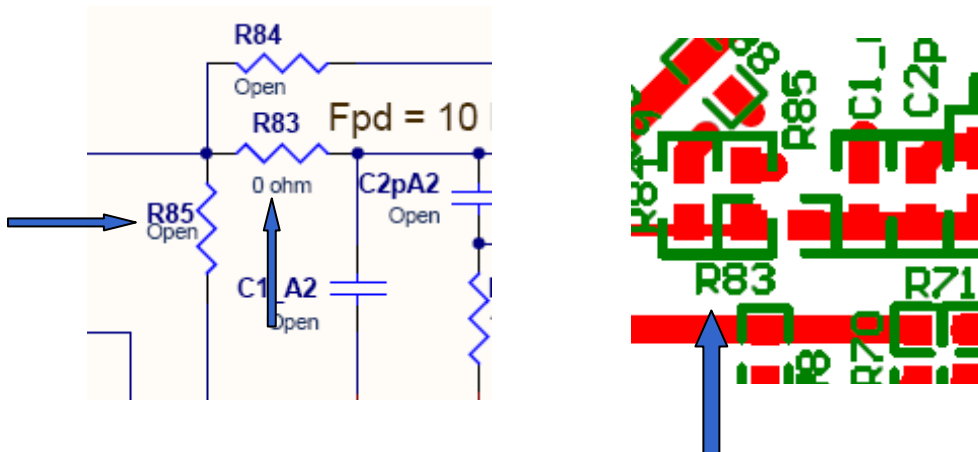

5. Disconnect power to the VCXO by removing the jumper on the Vcc_TP header across the traces labeled “VccSMA” and “VccAUXPlane”, if installed.

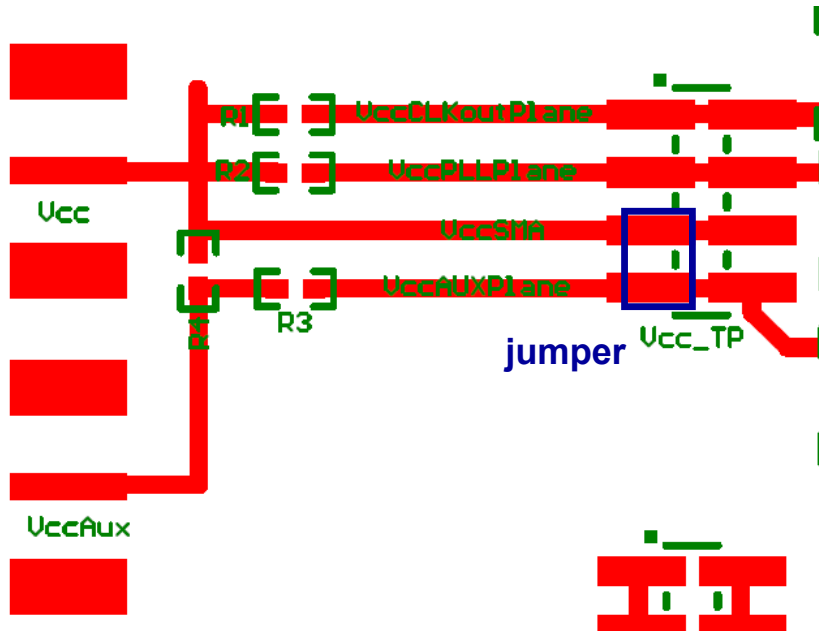

Appendix F: Quick Start for EVM Communication

Codeloader is the software used to communicate with the EVM (Please download the latest version from TI.com - <http://www.ti.com/tool/codeloader>). This EVM can be controlled through the uWire interface on board. There are two options in communicating with the uWire interface from the computer.

OPTION 1

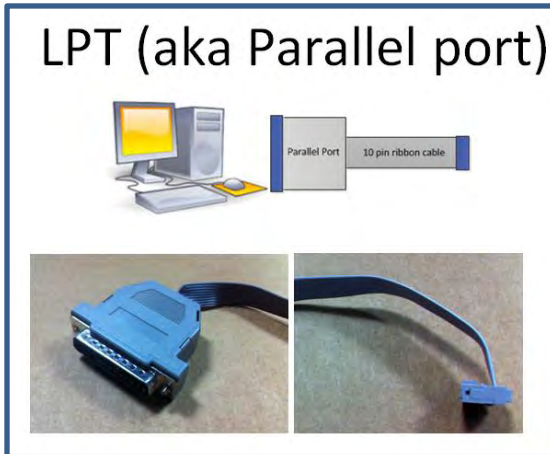

Open Codeloader.exe → Click “Select Device” → Click “Port Setup” tab → Click “LPT” (in Communication Mode)

OPTION 2

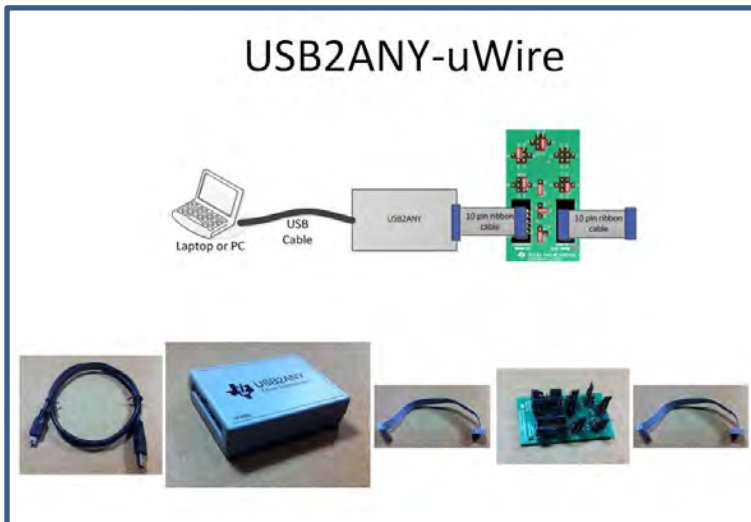

The Adapter Board

This table describes the pins configuration on the adapter board for each EVM board (See examples below table)

EVM	Jumper Bank								Code Loader Configuration
	A	B	C	D	E	F	G	H	
LMX2581	A4	B1	C2		E5	F1	G1	H1	BUFEN (pin 1), Trigger (pin 7)
LMX2541	A4		C3		E4	F1	G1	H1	CE (pin 1), Trigger (pin 10)
LMK0400x	A0		C3		E5	F1	G1	H1	GOE (pin 7)
LMK01000	A0		C1		E5	F1	G1	H1	GOE (pin 7)
LMK030xx	A0		C1		E5	F1	G1	H1	SYNC (pin 7)
LMK02000	A0		C1		E5	F1	G1	H1	SYNC (pin 7)
LMK0480x	A0	B2	C3		E5	F0	G0	H1	Status_CLKin1 (pin 3)
LMK04816/4906	A0	B2	C3		E5	F0	G0	H1	Status_CLKin1 (pin 3)
LMK01801	A0	B4	C5		E2	F0	G0	H1	Test (pin 3), SYNC0 (pin 10)
LMK0482x (pre-release)	A0	B5	C3	D2	E4	F0	G0	H1	CLKin1_SEL (pin 6), Reset (pin 10)
LMX2531	A0				E5	F2	G1	H2	Trigger (pin 1)
LMX2485/7	A0		C1		E5	F2	G1	H0	ENOSC (pin 7), CE (pin 10)
LMK03200	A0				E5	F0	G0	H1	SYNC (pin 7)
LMK03806	A0		C1		E5	F0	G0	H1	
LMK04100	A0		C1		E5	F1	G1	H1	

Example adapter configuration (LMK01801)

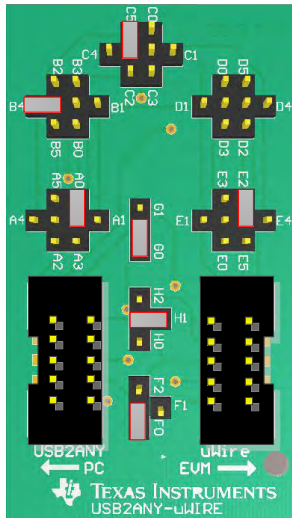

Open Codeloader.exe → Click “Select Device” → Click “Port Setup” Tab → Click “USB” (in Communication Mode)

**Remember to also make modifications in “Pin Configuration” Section according to Table above.*

EVALUATION BOARD/KIT/MODULE (EVM) ADDITIONAL TERMS

Texas Instruments (TI) provides the enclosed Evaluation Board/Kit/Module (EVM) under the following conditions:

The user assumes all responsibility and liability for proper and safe handling of the goods. Further, the user indemnifies TI from all claims arising from the handling or use of the goods.

Should this evaluation board/kit not meet the specifications indicated in the User's Guide, the board/kit may be returned within 30 days from the date of delivery for a full refund. THE FOREGOING LIMITED WARRANTY IS THE EXCLUSIVE WARRANTY MADE BY SELLER TO BUYER AND IS IN LIEU OF ALL OTHER WARRANTIES, EXPRESSED, IMPLIED, OR STATUTORY, INCLUDING ANY WARRANTY OF MERCHANTABILITY OR FITNESS FOR ANY PARTICULAR PURPOSE. EXCEPT TO THE EXTENT OF THE INDEMNITY SET FORTH ABOVE, NEITHER PARTY SHALL BE LIABLE TO THE OTHER FOR ANY INDIRECT, SPECIAL, INCIDENTAL, OR CONSEQUENTIAL DAMAGES.

Please read the User's Guide and, specifically, the Warnings and Restrictions notice in the User's Guide prior to handling the product. This notice contains important safety information about temperatures and voltages. For additional information on TI's environmental and/or safety programs, please visit www.ti.com/esh or contact TI.

No license is granted under any patent right or other intellectual property right of TI covering or relating to any machine, process, or combination in which such TI products or services might be or are used. TI currently deals with a variety of customers for products, and therefore our arrangement with the user is not exclusive. TI assumes no liability for applications assistance, customer product design, software performance, or infringement of patents or services described herein.

REGULATORY COMPLIANCE INFORMATION

As noted in the EVM User's Guide and/or EVM itself, this EVM and/or accompanying hardware may or may not be subject to the Federal Communications Commission (FCC) and Industry Canada (IC) rules.

For EVMs **not** subject to the above rules, this evaluation board/kit/module is intended for use for ENGINEERING DEVELOPMENT, DEMONSTRATION OR EVALUATION PURPOSES ONLY and is not considered by TI to be a finished end product fit for general consumer use. It generates, uses, and can radiate radio frequency energy and has not been tested for compliance with the limits of computing devices pursuant to part 15 of FCC or ICES-003 rules, which are designed to provide reasonable protection against radio frequency interference. Operation of the equipment may cause interference with radio communications, in which case the user at his own expense will be required to take whatever measures may be required to correct this interference.

General Statement for EVMs including a radio

User Power/Frequency Use Obligations: This radio is intended for development/professional use only in legally allocated frequency and power limits. Any use of radio frequencies and/or power availability of this EVM and its development application(s) must comply with local laws governing radio spectrum allocation and power limits for this evaluation module. It is the user's sole responsibility to only operate this radio in legally acceptable frequency space and within legally mandated power limitations. Any exceptions to this are strictly prohibited and unauthorized by Texas Instruments unless user has obtained appropriate experimental/development licenses from local regulatory authorities, which is responsibility of user including its acceptable authorization.

For EVMs annotated as FCC – FEDERAL COMMUNICATIONS COMMISSION Part 15 Compliant

Caution

This device complies with part 15 of the FCC Rules. Operation is subject to the following two conditions: (1) This device may not cause harmful interference, and (2) this device must accept any interference received, including interference that may cause undesired operation.

Changes or modifications not expressly approved by the party responsible for compliance could void the user's authority to operate the equipment.

FCC Interference Statement for Class A EVM devices

This equipment has been tested and found to comply with the limits for a Class A digital device, pursuant to part 15 of the FCC Rules. These limits are designed to provide reasonable protection against harmful interference when the equipment is operated in a commercial environment. This equipment generates, uses, and can radiate radio frequency energy and, if not installed and used in accordance with the instruction manual, may cause harmful interference to radio communications. Operation of this equipment in a residential area is likely to cause harmful interference in which case the user will be required to correct the interference at his own expense.

FCC Interference Statement for Class B EVM devices

This equipment has been tested and found to comply with the limits for a Class B digital device, pursuant to part 15 of the FCC Rules. These limits are designed to provide reasonable protection against harmful interference in a residential installation. This equipment generates, uses and can radiate radio frequency energy and, if not installed and used in accordance with the instructions, may cause harmful interference to radio communications. However, there is no guarantee that interference will not occur in a particular installation. If this equipment does cause harmful interference to radio or television reception, which can be determined by turning the equipment off and on, the user is encouraged to try to correct the interference by one or more of the following measures:

- Reorient or relocate the receiving antenna.
- Increase the separation between the equipment and receiver.
- Connect the equipment into an outlet on a circuit different from that to which the receiver is connected.
- Consult the dealer or an experienced radio/TV technician for help.

For EVMs annotated as IC – INDUSTRY CANADA Compliant

This Class A or B digital apparatus complies with Canadian ICES-003.

Changes or modifications not expressly approved by the party responsible for compliance could void the user's authority to operate the equipment.

Concerning EVMs including radio transmitters

This device complies with Industry Canada licence-exempt RSS standard(s). Operation is subject to the following two conditions: (1) this device may not cause interference, and (2) this device must accept any interference, including interference that may cause undesired operation of the device.

Concerning EVMs including detachable antennas

Under Industry Canada regulations, this radio transmitter may only operate using an antenna of a type and maximum (or lesser) gain approved for the transmitter by Industry Canada. To reduce potential radio interference to other users, the antenna type and its gain should be so chosen that the equivalent isotropically radiated power (e.i.r.p.) is not more than that necessary for successful communication.

This radio transmitter has been approved by Industry Canada to operate with the antenna types listed in the user guide with the maximum permissible gain and required antenna impedance for each antenna type indicated. Antenna types not included in this list, having a gain greater than the maximum gain indicated for that type, are strictly prohibited for use with this device.

Cet appareil numérique de la classe A ou B est conforme à la norme NMB-003 du Canada.

Les changements ou les modifications pas expressément approuvés par la partie responsable de la conformité ont pu vider l'autorité de l'utilisateur pour actionner l'équipement.

Concernant les EVMs avec appareils radio

Le présent appareil est conforme aux CNR d'Industrie Canada applicables aux appareils radio exempts de licence. L'exploitation est autorisée aux deux conditions suivantes : (1) l'appareil ne doit pas produire de brouillage, et (2) l'utilisateur de l'appareil doit accepter tout brouillage radioélectrique subi, même si le brouillage est susceptible d'en compromettre le fonctionnement.

Concernant les EVMs avec antennes détachables

Conformément à la réglementation d'Industrie Canada, le présent émetteur radio peut fonctionner avec une antenne d'un type et d'un gain maximal (ou inférieur) approuvé pour l'émetteur par Industrie Canada. Dans le but de réduire les risques de brouillage radioélectrique à l'intention des autres utilisateurs, il faut choisir le type d'antenne et son gain de sorte que la puissance isotrope rayonnée équivalente (p.i.r.e.) ne dépasse pas l'intensité nécessaire à l'établissement d'une communication satisfaisante.

Le présent émetteur radio a été approuvé par Industrie Canada pour fonctionner avec les types d'antenne énumérés dans le manuel d'usage et ayant un gain admissible maximal et l'impédance requise pour chaque type d'antenne. Les types d'antenne non inclus dans cette liste, ou dont le gain est supérieur au gain maximal indiqué, sont strictement interdits pour l'exploitation de l'émetteur.

【Important Notice for Users of EVMs for RF Products in Japan】

This development kit is NOT certified as Confirming to Technical Regulations of Radio Law of Japan

If you use this product in Japan, you are required by Radio Law of Japan to follow the instructions below with respect to this product:

1. Use this product in a shielded room or any other test facility as defined in the notification #173 issued by Ministry of Internal Affairs and Communications on March 28, 2006, based on Sub-section 1.1 of Article 6 of the Ministry's Rule for Enforcement of Radio Law of Japan,
2. Use this product only after you obtained the license of Test Radio Station as provided in Radio Law of Japan with respect to this product, or
3. Use of this product only after you obtained the Technical Regulations Conformity Certification as provided in Radio Law of Japan with respect to this product. Also, please do not transfer this product, unless you give the same notice above to the transferee. Please note that if you could not follow the instructions above, you will be subject to penalties of Radio Law of Japan.

Texas Instruments Japan Limited
(address) 24-1, Nishi-Shinjuku 6 chome, Shinjuku-ku, Tokyo, Japan

<http://www.tij.co.jp>

【無線電波を送信する製品の開発キットをお使いになる際の注意事項】

本開発キットは技術基準適合証明を受けておりません。

本製品のご使用に際しては、電波法遵守のため、以下のいずれかの措置を取っていただく必要がありますのでご注意ください。

1. 電波法施行規則第6条第1項第1号に基づく平成18年3月28日総務省告示第173号で定められた電波暗室等の試験設備でご使用いただく。
2. 実験局の免許を取得後ご使用いただく。
3. 技術基準適合証明を取得後ご使用いただく。

なお、本製品は、上記の「ご使用にあたっての注意」を譲渡先、移転先に通知しない限り、譲渡、移転できないものとします。

上記を遵守頂けない場合は、電波法の罰則が適用される可能性があることをご留意ください。

日本テキサス・インスツルメンツ株式会社
東京都新宿区西新宿6丁目24番1号
西新宿三井ビル

<http://www.tij.co.jp>

EVALUATION BOARD/KIT/MODULE (EVM) WARNINGS, RESTRICTIONS AND DISCLAIMERS

For Feasibility Evaluation Only, in Laboratory/Development Environments. Unless otherwise indicated, this EVM is not a finished electrical equipment and not intended for consumer use. It is intended solely for use for preliminary feasibility evaluation in laboratory/development environments by technically qualified electronics experts who are familiar with the dangers and application risks associated with handling electrical mechanical components, systems and subsystems. It should not be used as all or part of a finished end product.

Your Sole Responsibility and Risk. You acknowledge, represent and agree that:

1. You have unique knowledge concerning Federal, State and local regulatory requirements (including but not limited to Food and Drug Administration regulations, if applicable) which relate to your products and which relate to your use (and/or that of your employees, affiliates, contractors or designees) of the EVM for evaluation, testing and other purposes.
2. You have full and exclusive responsibility to assure the safety and compliance of your products with all such laws and other applicable regulatory requirements, and also to assure the safety of any activities to be conducted by you and/or your employees, affiliates, contractors or designees, using the EVM. Further, you are responsible to assure that any interfaces (electronic and/or mechanical) between the EVM and any human body are designed with suitable isolation and means to safely limit accessible leakage currents to minimize the risk of electrical shock hazard.
3. Since the EVM is not a completed product, it may not meet all applicable regulatory and safety compliance standards (such as UL, CSA, VDE, CE, RoHS and WEEE) which may normally be associated with similar items. You assume full responsibility to determine and/or assure compliance with any such standards and related certifications as may be applicable. You will employ reasonable safeguards to ensure that your use of the EVM will not result in any property damage, injury or death, even if the EVM should fail to perform as described or expected.
4. You will take care of proper disposal and recycling of the EVM's electronic components and packing materials.

Certain Instructions. It is important to operate this EVM within TI's recommended specifications and environmental considerations per the user guidelines. Exceeding the specified EVM ratings (including but not limited to input and output voltage, current, power, and environmental ranges) may cause property damage, personal injury or death. If there are questions concerning these ratings please contact a TI field representative prior to connecting interface electronics including input power and intended loads. Any loads applied outside of the specified output range may result in unintended and/or inaccurate operation and/or possible permanent damage to the EVM and/or interface electronics. Please consult the EVM User's Guide prior to connecting any load to the EVM output. If there is uncertainty as to the load specification, please contact a TI field representative. During normal operation, some circuit components may have case temperatures greater than 60°C as long as the input and output are maintained at a normal ambient operating temperature. These components include but are not limited to linear regulators, switching transistors, pass transistors, and current sense resistors which can be identified using the EVM schematic located in the EVM User's Guide. When placing measurement probes near these devices during normal operation, please be aware that these devices may be very warm to the touch. As with all electronic evaluation tools, only qualified personnel knowledgeable in electronic measurement and diagnostics normally found in development environments should use these EVMs.

Agreement to Defend, Indemnify and Hold Harmless. You agree to defend, indemnify and hold TI, its licensors and their representatives harmless from and against any and all claims, damages, losses, expenses, costs and liabilities (collectively, "Claims") arising out of or in connection with any use of the EVM that is not in accordance with the terms of the agreement. This obligation shall apply whether Claims arise under law of tort or contract or any other legal theory, and even if the EVM fails to perform as described or expected.

Safety-Critical or Life-Critical Applications. If you intend to evaluate the components for possible use in safety critical applications (such as life support) where a failure of the TI product would reasonably be expected to cause severe personal injury or death, such as devices which are classified as FDA Class III or similar classification, then you must specifically notify TI of such intent and enter into a separate Assurance and Indemnity Agreement.

Mailing Address: Texas Instruments, Post Office Box 655303, Dallas, Texas 75265
Copyright © 2013, Texas Instruments Incorporated

IMPORTANT NOTICE

Texas Instruments Incorporated and its subsidiaries (TI) reserve the right to make corrections, enhancements, improvements and other changes to its semiconductor products and services per JESD46, latest issue, and to discontinue any product or service per JESD48, latest issue. Buyers should obtain the latest relevant information before placing orders and should verify that such information is current and complete. All semiconductor products (also referred to herein as "components") are sold subject to TI's terms and conditions of sale supplied at the time of order acknowledgment.

TI warrants performance of its components to the specifications applicable at the time of sale, in accordance with the warranty in TI's terms and conditions of sale of semiconductor products. Testing and other quality control techniques are used to the extent TI deems necessary to support this warranty. Except where mandated by applicable law, testing of all parameters of each component is not necessarily performed.

TI assumes no liability for applications assistance or the design of Buyers' products. Buyers are responsible for their products and applications using TI components. To minimize the risks associated with Buyers' products and applications, Buyers should provide adequate design and operating safeguards.

TI does not warrant or represent that any license, either express or implied, is granted under any patent right, copyright, mask work right, or other intellectual property right relating to any combination, machine, or process in which TI components or services are used. Information published by TI regarding third-party products or services does not constitute a license to use such products or services or a warranty or endorsement thereof. Use of such information may require a license from a third party under the patents or other intellectual property of the third party, or a license from TI under the patents or other intellectual property of TI.

Reproduction of significant portions of TI information in TI data books or data sheets is permissible only if reproduction is without alteration and is accompanied by all associated warranties, conditions, limitations, and notices. TI is not responsible or liable for such altered documentation. Information of third parties may be subject to additional restrictions.

Resale of TI components or services with statements different from or beyond the parameters stated by TI for that component or service voids all express and any implied warranties for the associated TI component or service and is an unfair and deceptive business practice. TI is not responsible or liable for any such statements.

Buyer acknowledges and agrees that it is solely responsible for compliance with all legal, regulatory and safety-related requirements concerning its products, and any use of TI components in its applications, notwithstanding any applications-related information or support that may be provided by TI. Buyer represents and agrees that it has all the necessary expertise to create and implement safeguards which anticipate dangerous consequences of failures, monitor failures and their consequences, lessen the likelihood of failures that might cause harm and take appropriate remedial actions. Buyer will fully indemnify TI and its representatives against any damages arising out of the use of any TI components in safety-critical applications.

In some cases, TI components may be promoted specifically to facilitate safety-related applications. With such components, TI's goal is to help enable customers to design and create their own end-product solutions that meet applicable functional safety standards and requirements. Nonetheless, such components are subject to these terms.

No TI components are authorized for use in FDA Class III (or similar life-critical medical equipment) unless authorized officers of the parties have executed a special agreement specifically governing such use.

Only those TI components which TI has specifically designated as military grade or "enhanced plastic" are designed and intended for use in military/aerospace applications or environments. Buyer acknowledges and agrees that any military or aerospace use of TI components which have **not** been so designated is solely at the Buyer's risk, and that Buyer is solely responsible for compliance with all legal and regulatory requirements in connection with such use.

TI has specifically designated certain components as meeting ISO/TS16949 requirements, mainly for automotive use. In any case of use of non-designated products, TI will not be responsible for any failure to meet ISO/TS16949.

Products

Audio	www.ti.com/audio
Amplifiers	amplifier.ti.com
Data Converters	dataconverter.ti.com
DLP® Products	www.dlp.com
DSP	dsp.ti.com
Clocks and Timers	www.ti.com/clocks
Interface	interface.ti.com
Logic	logic.ti.com
Power Mgmt	power.ti.com
Microcontrollers	microcontroller.ti.com
RFID	www.ti-rfid.com
OMAP Applications Processors	www.ti.com/omap
Wireless Connectivity	www.ti.com/wirelessconnectivity

Applications

Automotive and Transportation	www.ti.com/automotive
Communications and Telecom	www.ti.com/communications
Computers and Peripherals	www.ti.com/computers
Consumer Electronics	www.ti.com/consumer-apps
Energy and Lighting	www.ti.com/energy
Industrial	www.ti.com/industrial
Medical	www.ti.com/medical
Security	www.ti.com/security
Space, Avionics and Defense	www.ti.com/space-avionics-defense
Video and Imaging	www.ti.com/video

TI E2E Community

e2e.ti.com