

# TWR-RF Module

---

## Reference Manual

Rev. 4.0

# Table of Contents

<b>1 TWR-RF Overview .....</b>	<b>4</b>
1.1 Contents.....	4
1.2 Features .....	5
1.3 Reference Documents .....	6
<b>2 Hardware Description .....</b>	<b>6</b>
2.1 System Power .....	6
2.2 MRB J4 & J5 Sockets.....	7
2.3 GPIO Customer Access .....	9
2.4 Buttons and Leds .....	10
2.5 USB.....	10
<b>3 Tower Elevator Connections .....</b>	<b>11</b>
<b>4 Schematics .....</b>	<b>18</b>
4.1 Schematic Rev B4.....	19
4.2 Schematic Rev C.....	22

## List of Figures

Figure 1. Freescale Tower System Overview .....	4
Figure 2. TWR-RF Module (Top Side) .....	5
Figure 3. TWR Elevator Block Diagram .....	6
Figure 4. J1 2X20 Pin out .....	10
Figure 5. Schematic Revision Identification .....	18
Figure 6. Schematic Revision History .....	18

## List of Tables

Table 1. J4 2x10 Socket .....	7
Table 2. J5 2x9 Socket .....	7
Table 3. J6 3x12 Header .....	9
Table 4. TWR-RF Primary Connector Pin out .....	11

## Revision History

Revision	Date	Changes
0.0	Jul,2011	Draft for TWR-RF REV A
1.0	Sep, 2011	TWR-RF REV B
2.0	Feb, 2012	Changes to support Feb 8 release
3.0	Jun, 2012	TWR-RF REV C
4.0	Feb, 2014	Changes to reflect new MRB products

# 1 TWR-RF Overview

The TWR-RF is a Tower Controller Module compatible with the Freescale Tower System. It can function as a stand-alone, low-cost platform for the evaluation of Freescale’s wireless mounted on the appropriate Modular Reference Board (MRB).

The TWR-RF module works with the Tower Elevator Modules (TWR-ELEV) and can also be combined with other Freescale Tower peripheral modules to create development platforms for a wide variety of applications. Figure 1 provides an overview of the Freescale Tower System.

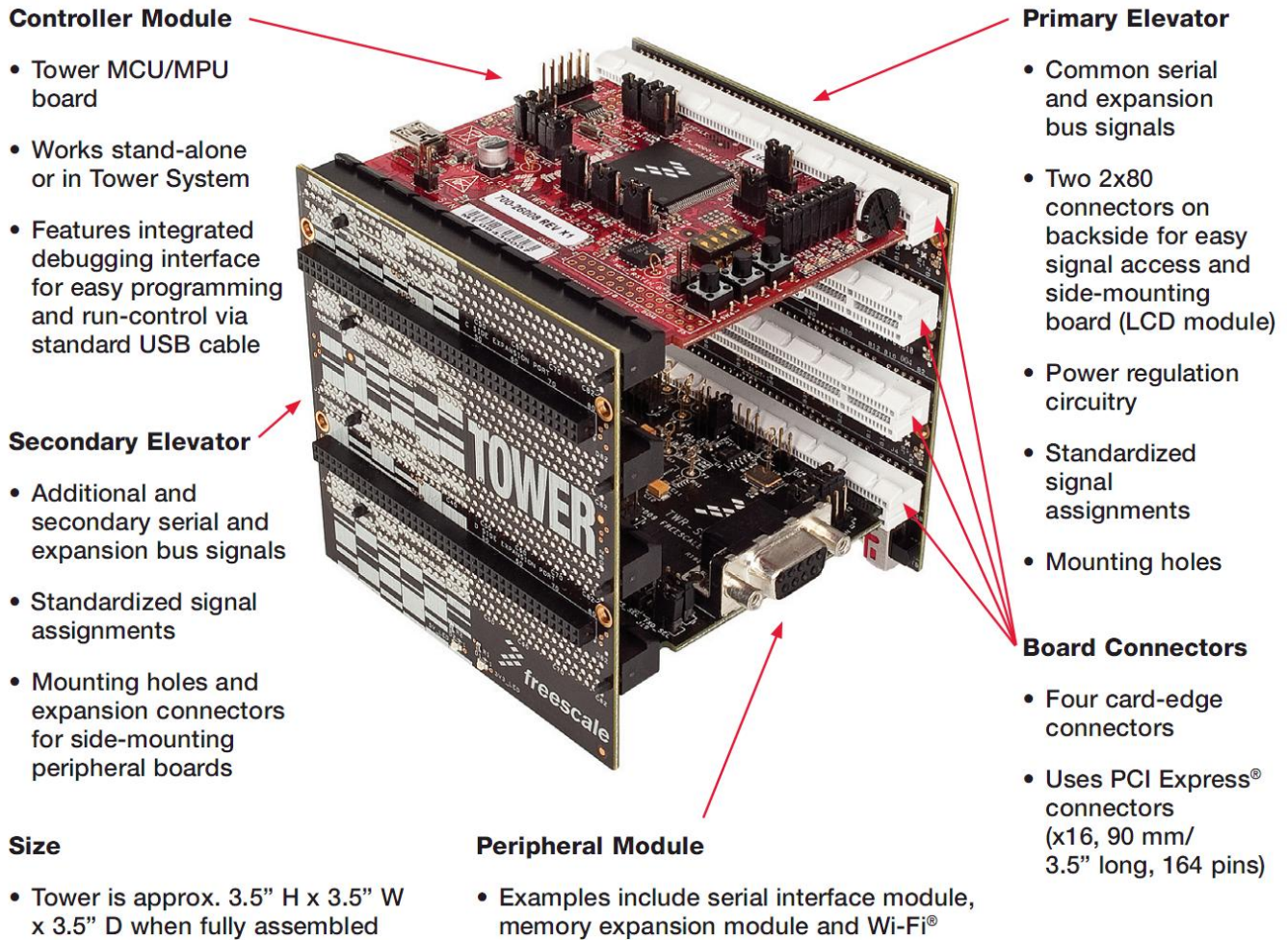

Figure 1. Freescale Tower System Overview

## 1.1 Contents

The TWR-RF module includes:

- TWR-RF board assembly only (The different available MRBs are available separately)

## 1.2 Features

Figure 2 shows the TWR-RF module with some key features called out. The following list summarizes TWR-RF Module features:

- Standard sockets 100 mils spacing J5 and J4 (2X9 and 2x10) to connect any of Freescale’s line of product-specific Modular Reference Board (MRB)
- Standard header 100 mils spacing J1 (2x20) to enable signalling path to TWR primary and secondary connectors.
- Standard header 100 mils spacing J6 (3x12) to enable signalling to onboard HW and USB interface or to TWR system Hardware
- On-board regulator to supply power to the MRB
- Four (4) user-controllable LEDs
- Four (4) user pushbutton switches
- USB Mini-B connector

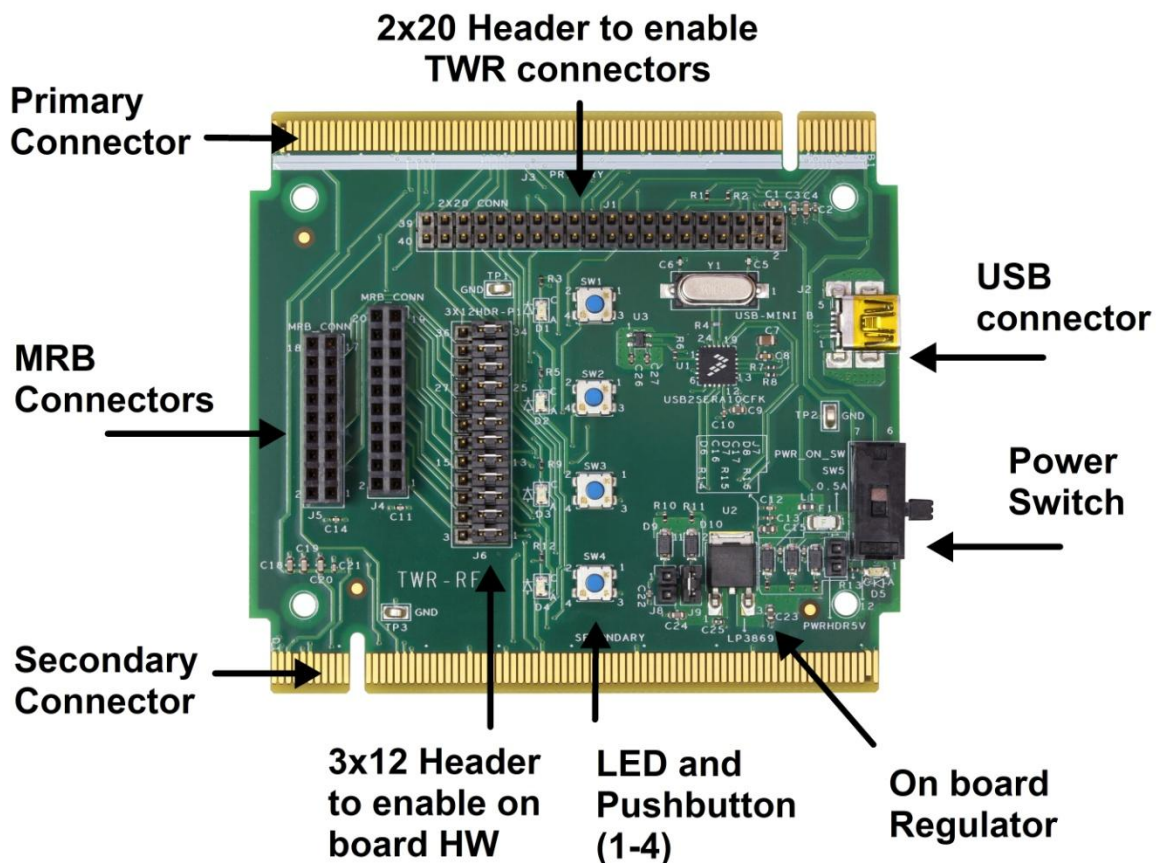

Figure 2. TWR-RF Module (Top Side)

## 1.3 Reference Documents

See the documents that can be found in the documentation section of [freescale.com/802154](http://freescale.com/802154) or [freescale.com/tower](http://freescale.com/tower) for more information on the Freescale 802.15.4 and sub 1 GHz product family Tower System, and MCU Modules.

## 2 Hardware Description

The TWR-RF module is a motherboard for use with any of Freescale's line of product-specific MBR boards to enable their use in the Tower system.

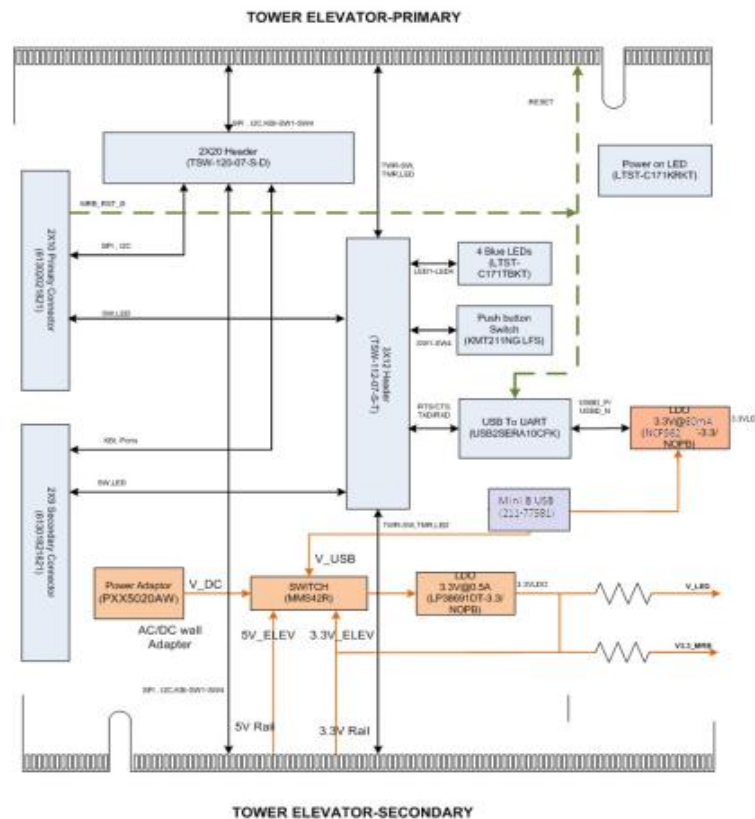

Figure 3. TWR Elevator Block Diagram

### 2.1 System Power

In stand-alone operation, the main power source for the TWR-RF module is derived from the 5.0V input from either the USB Mini-B connector, J2, or from External supply 2-pin header, J7. A low-dropout regulator provides a 3.3V supply from the 5.0V input voltage. Refer to sheet 5 of the TWR-RF schematics for more details.

When installed into a Tower System, the TWR-RF module can be powered from either an on-board source or from another source in the assembled Tower System. Use J9 and J8 to enable/disable both the on-board and off-board sources available.

The 3.3V power supplied to the MCU is routed through jumper J9. The jumper shunt can be removed to allow for either of the following:

- 1) Alternate supply voltages to be injected.
- 2) The measurement of power consumed.

## 2.2 MRB J4 & J5 Sockets

The TWR-RF module features two sockets that can accept any of Freescale's line of product-specific MRB boards. See the relevant documentation for more information on these MRB boards. These standard 100mil sockets provide access to I2C, SPI, IRQs, GPIOs, timers, reset, and voltage supplies to the MRBs. The pin out for sockets J4 and J5 are defined in the following tables.

Table 1. J4 2x10 Socket

HEADER PIN #	MRB PIN NAME	DESCRIPTION / COMMENTS
1	VDD	VDD supply to module (Pin 19)
2	NSS/SS	NOT CONNECTED --SPI Bus Slave Select (SS) (Pad 59)
3	VSS/GND	Module ground (Pin 4, 20)
4	MOSI	NOT CONNECTED --SPI Bus MOSI signal (Pad 58)
5	PTB1/TXD	UART TXD output from MCU → UART RXD to the USB interface (Pin 15)
6	MISO	NOT CONNECTED --SPI Bus MISO signal (Pad 60)
7	PTB0/RXD	UART RXD Input to MCU → UART TXD to the USB interface (Pin 16)
8	SPICLK	NOT CONNECTED --SPI Clock (SPISCK) (Pad 57)
9	PTC0/TPM3CH0	GPIO / Timer IO (Pin 12) (LED 3 -TWR)
10	RESET	Reset (Pin 33)
11	PTA2/SDA	I2C Bus data signal (SDA) (Pin 25)
12	PTD4/KBI2P4	UART RTS input into MCU (implemented in software <sup>1</sup> )
13	PTA3/SCL	I2C Bus clock signal (SCL) (Pin 24)
14	PTD3/KBI2P3	UART CTS output from MCU (implemented in software <sup>1</sup> )
15	GND	Module ground (Pin 4, 20)
16	DIO5/CLKOUT	FX Crystal Oscillator frequency (Pin 54)
17	PTA0/KBI1P0	Port A Bit 0 / KBI1 Input Bit 0 (Pin 27) (SW 1-TWR)
18	PTA1/KBI1P1	Port A Bit 1 / KBI1 Input Bit 1 (Pin 26) (SW 2 -TWR)
19	PTB2/KBI1P6	Port B Bit 2 / KBI1 Input Bit 6 (Pin 14) (SW 3 -TWR)
20	PTB3/KBI1P7	Port B Bit 3 / KBI1 Input Bit 7 (Pin 13) (SW 4 -TWR)

Table 2. J5 2x9 Socket

HEADER PIN #	PIN NAME	DESCRIPTION / COMMENTS
1	VBATT	VBATT supply to MRB
2	PTB7/EXTAL	Port B Bit 7 (Pin 5)
3	PTB6/XTAL_32K	Port B Bit 6 (Pin 6) (LED1 -TWR)
4	GND	Module GND

5	PTB5/TPM1CH1	Port B Bit 5 (Pin 7)
6	PTB4/TPM2CH1	Port B Bit 4 (Pin 8)
7	PTC3/TPM3CH3	Port C Bit 3 (Pin 9) (LED 2)
8	PTC2/TPM3CH2	Port C Bit 2 (Pin 10)
9	PTC1/TPM3CH1	Port C Bit 1 (Pin 11)
10	PTA7/TPM2CH2	Port A Bit 7 (Pin 17)
11	PTA6/TPM1CH2	Port A Bit 6 (Pin 18)
12	PTC7	Port C Bit 7 (Pin 28)
13	PTC6	Port C Bit 6 (Pin 29)
14	PTC5/TPM3CH5	Port C Bit 5 (Pin 31)
15	PTC4/TPM3CH4	Port C Bit 4 (Pin 32) (LED4 -TWR)
16	NC	NC
17	NC	NC
18	GND	Module ground



## 2.3 GPIO Customer Access

The TWR-RF provides a standard 100mil 3x12 header to allow routing to the ON board hardware or to the lateral Tower system connectors. Jumpers may be installed for normal operation to use the on-board hardware. See the following table for connector J6 signal connections.

Table 3. J6 3x12 Header

HEADER PIN #	PIN NAME	DESCRIPTION / COMMENTS
1	UART_TXD_RF_TWR	On board TXD from USB-UART transceiver IC
2	PTB1/TXD	MRB UART TXD
3	UART_TXD_TWR	UART TXD Tower Primary / Secondary Conn (A42)
4	UART_RXD_RF_TWR	On board RXD from USB-UART transceiver IC
5	PTB0/RXD	MRB UART RXD
6	UART_RXD_TWR	UART RXD Tower Primary / Secondary Conn (A41)
7	UART_CTS_RF_TWR	On board CTS from USB-UART transceiver IC
8	PTD3/KBI2P3	MRB UART CTS
9	UART_CTS_TWR	UART CTS Tower Primary / Secondary Conn (A9)
10	UART_RTS_RF_TWR	On board RTS from USB-UART transceiver IC
11	PTD4/KBI2P4	MRB UART RTS
12	UART_RTS_TWR	UART RTS Tower Primary / Secondary Conn (B21)
13	SW1_RF_TWR	On board SW1
14	PTA0/KBI1P0	MRB J4-17
15	SW1_TWR	Tower Primary / Secondary Conn (A45)
16	SW2_RF_TWR	On board SW2
17	PTA1/KBI1P1	MRB J4-18
18	SW2_TWR	Tower Primary / Secondary Conn (A46)
19	SW3_RF_TWR	On board SW3
20	PTB2/KBI1P6	MRB J4-19
21	SW3_TWR	Tower Primary / Secondary Conn (A47)
22	SW4_RF_TWR	On board SW4
23	PTB3/KBI1P7	MRB J4-20
24	SW4_TWR	Tower Primary / Secondary Conn (A48)
25	LED1_RF_TWR	On board LED1
26	PTB6/XTAL_32K	MRB J6- 3
27	LED1_TWR	Tower Primary / Secondary Conn (A50)
28	LED2_RF_TWR	On board LED2
29	PTC3/TPM3CH3	MRB J5-7

30	LED2_TWR	Tower Primary / Secondary Conn (A51)
31	LED3_RF_TWR	On board LED3
32	PTC0/TPM3CH0	MRB J4-9
33	LED3_TWR	Tower Primary / Secondary Conn (A52)
34	LED4_RF_TWR	On board LED4
35	PTC4/TPM3CH4	MRB J5-15
36	LED4_TWR	Tower Primary / Secondary Conn (A53)

The TWR-RF provides a standard 100mil 2x20 header to allow routing to the TWR Elevator side connectors or to external hardware. Jumpers may be installed to allow communication with other TWR system boards. See Figure 4 for Pin connector signal connections.

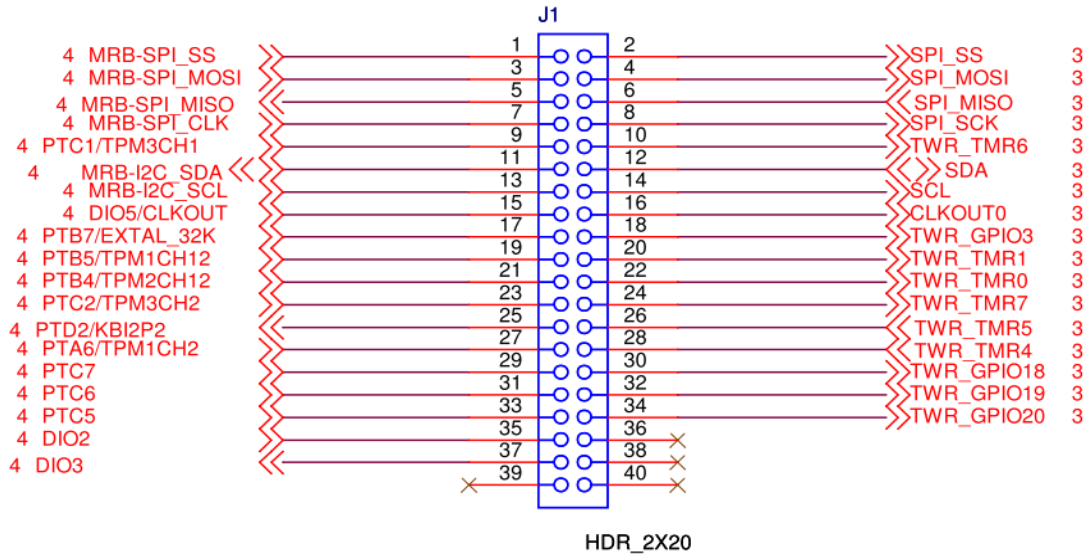

Figure 4. J1 2X20 Pin out

## 2.4 Buttons and Leds

The TWR-RF includes the following:

- An ON/OFF switch to control all possible voltage resources.
- Reset signal comes from the Reset (MCU) on the MRB.
- Four push buttons and four LEDs controlled by the MRB onboard MCU.
- A Power-On red LED is included.

## 2.5 USB

The TWR-RF includes USB2SER which is a USB to UART bridge controller. It supports USB 2.0 full-speed and TTL RS232 or RS485 UART with options for hardware flow control, software flow control (Xon-Xoff), even or odd parity and stop bits configuration. The USB2SER is fully compliant with the USB 2.0 specification.

### 3 Tower Elevator Connections

The TWR-RF features two expansion card-edge connectors that interface to the Primary and Secondary Elevator boards in a Tower system. The following tables Table 4 provide the pin outs for the Primary and Secondary Connectors.

Table 4. TWR-RF Primary Connector Pin out

TWR Primary Connector											
Side B						Side A					
Pin #	Name	Group	Usage	Used	Jmp	Pin #	Name	Group	Usage	Used	Jmp
B1	5V	Power	5.0V Power	X	X	A1	5V	Power	5.0V Power	X	X
B2	GND	Power	Ground	X		A2	GND	Power	Ground	X	
B3	3.3V	Power	3.3V Power	X	X	A3	3.3V	Power	3.3V Power	X	X
B4	ELE_PS_SENSE	Power	Elevator Power Sense			A4	3.3V	Power	3.3V Power	X	X
B5	GND	Power	Ground	X		A5	GND	Power	Ground	X	
B6	GND	Power	Ground	X		A6	GND	Power	Ground	X	
B7	SPI1_CLK / SDHC1_CLK	SPI 1 / SDHC1	SPI_SCK (J4-8)	X	X	A7	SCL0	I2C 0	SCL (J4-13)	X	X
B8	SPI1_CS1 / SDHC1_CS1	SPI 1 / SDHC1	SPI_SS (J4-2)	X	X	A8	SDA0	I2C 0	SDA (J4-11)	X	X
B9	SPI1_CS0 / SDHC1_CS0	SPI 1 / SDHC1	SPI_SS (J4-2)	X	X	A9	GPIO9 / CTS1	GPIO/ UART	UART CTS (J6-9)	X	X
B10	SPI1_MOSI / SDHC1_CMD	SPI 1 / SDHC1	SPI_MOSI (J4-4)	X	X	A10	GPIO8 / SDHC_D2	GPIO/ SDHC1			
B11	SPI1_MISO / SDHC1_D0	SPI 1 / SDHC1	SPI_MISO (J4-6)	X	X	A11	GPIO7 / SD_WP_DET	GPIO/ SD / SDHC1			
Mechanical Key											
B12	ETH_COL	Ethernet				A12	ETH_CRS	Ethernet			
B13	ETH_RXER	Ethernet				A13	ETH_MDC	Ethernet			
B14	ETH_TXCLK	Ethernet				A14	ETH_MDIO	Ethernet			
B15	ETH_TXEN	Ethernet				A15	ETH_RXCLK	Ethernet			
B16	ETH_TXER	Ethernet				A16	ETH_RXDV	Ethernet			
B17	ETH_TXD3	Ethernet				A17	ETH_RXD3	Ethernet			
B18	ETH_TXD2	Ethernet				A18	ETH_RXD2	Ethernet			
B19	ETH_TXD1	Ethernet				A19	ETH_RXD1	Ethernet			

B20	ETH_TXD0	Ethernet				A20	ETH_RXD0	Ethernet			
B21	GPIO1 / RTS1	GPIO/ UART	UART_RTS (J6-12)	X	X	A21	SSI_M CLK	SSI			
B22	GPIO2 / SDHC1_D1	GPIO/ SDHC1		X	X	A22	SSI_BC LK	SSI			
B23	GPIO3	GPIO	J1-18	X	X	A23	SSI_FS	SSI			
B24	CLKIN0	Clock				A24	SSI_RX D	SSI			
B25	CLKOUT1	Clock				A25	SSI_TX D	SSI			
B26	<b>GND</b>	<b>Power</b>	<b>Ground</b>	<b>X</b>		A26	<b>GND</b>	<b>Power</b>	<b>Ground</b>	<b>X</b>	
B27	AN7	ADC				A27	AN3	ADC			
B28	AN6	ADC				A28	AN2	ADC			
B29	AN5	ADC				A29	AN1	ADC			
B30	AN4	ADC				A30	AN0	ADC			
B31	<b>GND</b>	<b>Power</b>	<b>Ground</b>	<b>X</b>		A31	<b>GND</b>	<b>Power</b>	<b>Ground</b>	<b>X</b>	
B32	DAC1	DAC				A32	DAC0	DAC			
B33	TMR3	Timer				A33	TMR1	Timer	J1-20	X	X
B34	TMR2	Timer				A34	TMR0	Timer	J1-22	X	X
B35	GPIO4	GPIO				A35	GPIO6	GPIO			
B36	<b>3.3V</b>	<b>Power</b>	<b>3.3V Power</b>	<b>X</b>		A36	<b>3.3V</b>	<b>Power</b>	<b>3.3V Power</b>	<b>X</b>	
B37	PWM7	PWM				A37	PWM3	PWM			
B38	PWM6	PWM				A38	PWM2	PWM			
B39	PWM5	PWM				A39	PWM1	PWM			
B40	PWM4	PWM				A40	PWM0	PWM			
B41	CANRX	CAN				A41	RXD0	UART 0			
B42	CANTX	CAN				A42	TXD0	UART 0			
B43	1WIRE	1-Wire				A43	RXD1	UART 1	J6 -6	X	X
B44	SPIO_MISO	SPI 0				A44	TXD1	UART 1	J6-3	X	X
B45	SPIO_MOSI	SPI 0				A45	VSSA				
B46	SPIO_CS0	SPI 0				A46	VDDA				
B47	SPIO_CS1	SPI 0				A47	VREFA 1				
B48	SPIO_CLK	SPI 0				A48	VREFA 1				
B49	<b>GND</b>	<b>Power</b>	<b>Ground</b>	<b>X</b>		A49	<b>GND</b>	<b>Power</b>	<b>Ground</b>	<b>X</b>	
B50	SCL1	I2C 1				A50	GPIO1 4	GPIO	LED 3 (J6-27)	X	X
B51	SDA1	I2C 1				A51	GPIO1 5	GPIO	LED 3 (J6-30)	X	X
B52	GPIO5 / SD_CARD_DET	GPIO/ SD / SDHC1				A52	GPIO1 6	GPIO	LED 3 (J6-33)	X	X
B53	USB0_DP_PDO WN	USB 0				A53	GPIO1 7	GPIO	LED 3 (J6-36)	X	X
B54	USB0_DM_PD OWN	USB 0				A54	USB0_ DM	USB 0			

B55	IRQ_H	Interrupt				A55	USB0_DP	USB 0			
B56	IRQ_G	Interrupt				A56	USB0_ID	USB 0			
B57	IRQ_F	Interrupt				A57	USB0_VBUS	USB 0			
B58	IRQ_E	Interrupt				A58	TMR7	Timer	J1-24	X	X
B59	IRQ_D	Interrupt				A59	TMR6	Timer	J1-10	X	X
B60	IRQ_C	Interrupt				A60	TMR5	Timer	J1-26	X	X
B61	IRQ_B	Interrupt				A61	TMR4	Timer	J1-28	X	X
B62	IRQ_A	Interrupt				A62	RSTIN_b	Reset	RSTb (J4-10)	X	
B63	EBI_ALE/EBI_CS1_b	EBI				A63	RSTOUT_b	Reset			
B64	EBI_CS0_b	EBI				A64	CLKOUT0	Clock	J1-16	X	X
B65	<b>GND</b>	<b>Power</b>	<b>Ground</b>	<b>X</b>		A65	<b>GND</b>	<b>Power</b>	<b>Ground</b>	<b>X</b>	
B66	EBI_AD15	EBI				A66	EBI_AD14	EBI			
B67	EBI_AD16	EBI				A67	EBI_AD13	EBI			
B68	EBI_AD17	EBI				A68	EBI_AD12	EBI			
B69	EBI_AD18	EBI				A69	EBI_AD11	EBI			
B70	EBI_AD19	EBI				A70	EBI_AD10	EBI			
B71	EBI_R/W_b	EBI				A71	EBI_AD9	EBI			
B72	EBI_OE_b	EBI				A72	EBI_AD8	EBI			
B73	EBI_D7	EBI				A73	EBI_AD7	EBI			
B74	EBI_D6	EBI				A74	EBI_AD6	EBI			
B75	EBI_D5	EBI				A75	EBI_AD5	EBI			
B76	EBI_D4	EBI				A76	EBI_AD4	EBI			
B77	EBI_D3	EBI				A77	EBI_AD3	EBI			
B78	EBI_D2	EBI				A78	EBI_AD2	EBI			
B79	FB_D1	Flexbus				A79	FB_AD1	Flexbus			
B80	FB_D0	Flexbus				A80	FB_AD0	Flexbus			
B81	<b>GND</b>	<b>Power</b>	<b>Ground</b>	<b>X</b>		A81	<b>GND</b>	<b>Power</b>	<b>Ground</b>	<b>X</b>	
B82	<b>3.3V</b>	<b>Power</b>	<b>3.3V Power</b>	<b>X</b>		A82	<b>3.3V</b>	<b>Power</b>	<b>3.3V Power</b>	<b>X</b>	

TWR-802154 Secondary Connector											
Side B						Side A					
Pin #	Name	Group	Usage	Used	Jmp	Pin #	Name	Group	Usage	Used	Jmp
D1	5V	Power	5.0V Power	X	X	C1	5V	Power	5.0V Power	X	X
D2	GND	Power	Ground	X		C2	GND	Power	Ground	X	
D3	3.3V	Power	3.3V Power	X	X	C3	3.3V	Power	3.3V Power	X	X
D4	ELE_PS_SENSE	Power	Elevator Power Sense			C4	3.3V	Power	3.3V Power	X	X
D5	GND	Power	Ground	X		C5	GND	Power	Ground	X	
D6	GND	Power	Ground	X		C6	GND	Power	Ground	X	
D7	SPI2_CLK	SPI 2				C7	SCL2	I2C 2			
D8	SPI2_CS1	SPI 2				C8	SDA2	I2C 2			
D9	SPI2_CS0	SPI 2				C9	GPIO2_5	GPIO	SW 1 (J6-16)	X	X
D10	SPI2_MOSI	SPI 2				C10	USB_S TOP	ULPI			
D11	SPI2_MISO	SPI 2				C11	USB_C LK	ULPI			
Mechanical Key											
D12	ETH_COL	Ethernet				C12	GPIO2_6	GPIO	SW 2 (J6-18)	X	X
D13	ETH_RXER	Ethernet				C13	ETH_M DC	Ethernet			
D14	ETH_TXCLK	Ethernet				C14	ETH_M DIO	Ethernet			
D15	ETH_TXEN	Ethernet				C15	ETH_R XCLK	Ethernet			
D16	GPIO18	GPIO	J1-30	X	X	C16	ETH_R XDV	Ethernet			
D17	GPIO19	GPIO	J1-32	X	X	C17	GPIO2_7	GPIO			
D18	GPIO20	GPIO	J1-34	X	X	C18	GPIO2_8	GPIO			
D19	ETH_TXD1	Ethernet				C19	ETH_R XD1	Ethernet			
D20	ETH_TXD0	Ethernet				C20	ETH_R XD0	Ethernet			
D21	ULPI_NEXT/USB1_DM	ULPI / USB 1				C21	ULPI_D ATA0/USB3_DM	ULPI / USB 3			
D22	ULPI_DIR/USB1_DP	ULPI / USB 1				C22	ULPI_D ATA1/USB3_DP	ULPI / USB 3			

D23	UPLI_DATA5/U SB2_DM	ULPI / USB 2				C23	ULPI_D ATA2/ USB4_ DM	ULPI / USB 4			
D24	UPLI_DATA6/U SB2_DP	ULPI / USB 2				C24	ULPI_D ATA3/ USB4_ DP	ULPI / USB 4			
D25	UPLI_DATA7	ULPI				C25	ULPI_D ATA4	ULPI			
D26	<b>GND</b>	<b>Power</b>	<b>Ground</b>	<b>X</b>		C26	<b>GND</b>	<b>Power</b>	<b>Ground</b>	<b>X</b>	
D27	LCD_HSYNC / LCD24	Display				C27	AN11	ADC			
D28	LCD_VSYNC / LCD25	Display				C28	AN10	ADC			
D29	AN13	ADC				C29	AN9	ADC			
D30	AN12	ADC				C30	AN8	ADC			
D31	<b>GND</b>	<b>Power</b>	<b>Ground</b>	<b>X</b>		C31	<b>GND</b>	<b>Power</b>	<b>Ground</b>	<b>X</b>	
D32	LCD_CLK / LCD26	Display				C32	GPIO2 9	GPIO	SW 3 (J6-21)	<b>X</b>	<b>X</b>
D33	TMR11	Timer				C33	TMR9	Timer			
D34	TMR10	Timer				C34	TMR8	Timer			
D35	GPIO21	GPIO				C35	GPIO3 0	GPIO	SW 4 (J6-24)	<b>X</b>	<b>X</b>
D36	<b>3.3V</b>	<b>Power</b>	<b>3.3V Power</b>	<b>X</b>	<b>X</b>	C36	<b>3.3V</b>	<b>Power</b>	<b>3.3V Power</b>	<b>X</b>	<b>X</b>
D37	PWM15	PWM				C37	PWM1 1	PWM			
D38	PWM14	PWM				C38	PWM1 0	PWM			
D39	PWM13	PWM				C39	PWM9	PWM			
D40	PWM12	PWM				C40	PWM8	PWM			
D41	CANRX1	CAN				C41	RXD2 / TSI0	UART 2 / TSI			
D42	CANTX1	CAN				C42	TXD2 / TSI1	UART 2 / TSI			
D43	GPIO22	GPIO				C43	RTS2 / TSI2	UART 2 / TSI			
D44	LCD_OE / LCD27	Display				C44	CTS2 / TSI3	UART 2 / TSI			
D45	LCD_D0 / LCD0	Display				C45	RXD3 / TSI4	UART 3 / TSI			
D46	LCD_D1 / LCD1	Display				C46	TXD3 / TSI5	UART 3 / TSI			
D47	LCD_D2 / LCD2	Display				C47	RTS3 / TSI6	UART 3 / TSI			
D48	LCD_D3 / LCD3	Display				C48	CTS3 / TSI7	UART 3 / TSI			
D49	<b>GND</b>	<b>Power</b>	<b>Ground</b>	<b>X</b>		C49	<b>GND</b>	<b>Power</b>	<b>Ground</b>	<b>X</b>	
D50	GPIO23	GPIO				C50	LCD_D 4 /	Display			

							LCD4				
D51	GPIO24	GPIO				C51	LCD_D 5 / LCD5	Display			
D52	LCD_D12 / LCD12	Display				C52	LCD_D 6 / LCD6	Display			
D53	LCD_D13 / LCD13	Display				C53	LCD_D 7 / LCD7	Display			
D54	LCD_D14 / LCD14	Display				C54	LCD_D 8 / LCD8	Display			
D55	IRQ_P/SPI2_CS 2	Interrupt / SPI 2				C55	LCD_D 9 / LCD9	Display			
D56	IRQ_O/SPI2_C S3	Interrupt / SPI 2				C56	LCD_D 10 / LCD10	Display			
D57	IRQ_N	Interrupt				C57	LCD_D 11 / LCD11	Display			
D58	IRQ_M	Interrupt				C58	TMR16	Timer			
D59	IRQ_L	Interrupt				C59	TMR15	Timer			
D60	IRQ_K	Interrupt				C60	TMR14	Timer			
D61	IRQ_J	Interrupt				C61	TMR13	Timer			
D62	IRQ_I	Interrupt				C62	LCD_D 15 / LCD15	Display			
D63	LCD_D18 / LCD18	Display				C63	LCD_D 16 / LCD16	Display			
D64	LCD_D19 / LCD19	Display				C64	LCD_D 17 / LCD17	Display			
D65	<b>GND</b>	<b>Power</b>	<b>Ground</b>	<b>X</b>		C65	<b>GND</b>	<b>Power</b>	<b>Ground</b>	<b>X</b>	
D66	EBI_AD20 / LCD42	External Bus Interface / Display				C66	EBI_BE 3 / LCD28	External Bus Interface / Display			
D67	EBI_AD21 / LCD43	External Bus Interface / Display				C67	EBI_BE 2 / LCD29	External Bus Interface / Display			
D68	EBI_AD22 / LCD44	External Bus Interface / Display				C68	EBI_BE 1 / LCD30	External Bus Interface / Display			
D69	EBI_AD23 / LCD45	External Bus Interface / Display				C69	EBI_BE 0 / LCD31	External Bus Interface / Display			



D70	EBI_AD24 / LCD46	External Bus Interface / Display				C70	EBI_TSIZE0 / LCD32	External Bus Interface / Display			
D71	EBI_AD25 / LCD47	External Bus Interface / Display				C71	EBI_TSIZE1 / LCD33	External Bus Interface / Display			
D72	EBI_AD26 / LCD48	External Bus Interface / Display				C72	EBI_TSI / LCD34	External Bus Interface / Display			
D73	EBI_AD27 / LCD49	External Bus Interface / Display				C73	EBI_TBST / LCD35	External Bus Interface / Display			
D74	EBI_AD28 / LCD50	External Bus Interface / Display				C74	TB_TA / LCD36	External Bus Interface / Display			
D75	EBI_AD29 / LCD51	External Bus Interface / Display				C75	EBI_CS4 / LCD37	External Bus Interface / Display			
D76	EBI_AD30 / LCD52	External Bus Interface / Display				C76	EBI_CS3 / LCD38	External Bus Interface / Display			
D77	EBI_AD31 / LCD53	External Bus Interface / Display				C77	EBI_CS2 / LCD39	External Bus Interface / Display			
D78	LCD_D20 / LCD20	Display				C78	EBI_CS1 / LCD40	External Bus Interface / Display			
D79	LCD_D21 / LCD21	Display				C79	GPIO31 / LCD41	GPIO			
D80	LCD_D22 / LCD22	Display				C80	LCD_D23 / LCD23	Display			
D81	<b>GND</b>	<b>Power</b>	<b>Ground</b>	<b>X</b>		C81	<b>GND</b>	<b>Power</b>	<b>Ground</b>	<b>X</b>	
D82	<b>3.3V</b>	<b>Power</b>	<b>3.3V Power</b>	<b>X</b>	<b>X</b>	C82	<b>3.3V</b>	<b>Power</b>	<b>3.3V Power</b>	<b>X</b>	<b>X</b>

## 4 Schematics

The TWR-RF boards have a Label on bottom side to identify the schematic revision Figure 5. Also, any change in revisions is documented in the schematic revision history Figure 6.

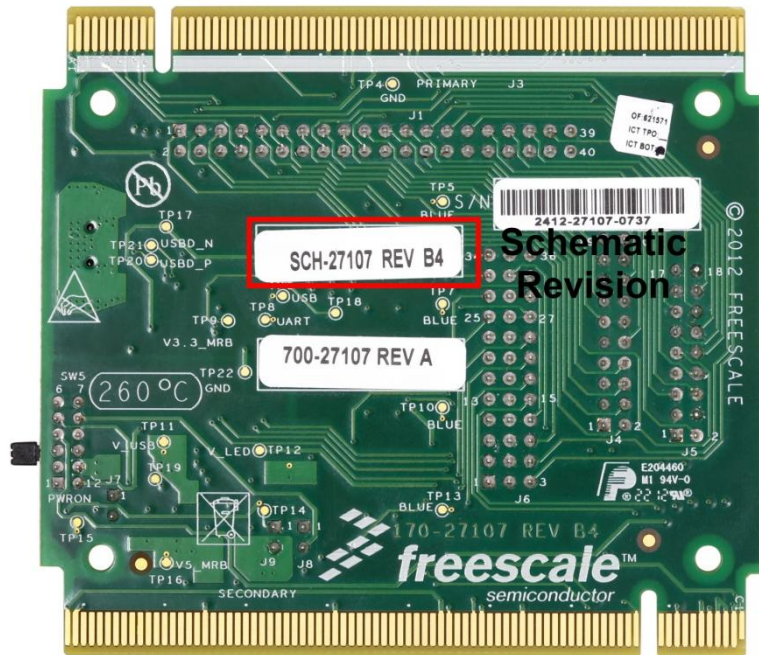

Figure 5. Schematic Revision Identification

Revision History			
Revision	Date	Description	
X1	11-Apr-11	Initial Draft	SV SIVASANKAR
A	10-May-11	1. Prototype Release	SV SIVASANKAR
B	5-Aug-11	1. Replace USB Type B with a USB Mini-B 2. Delete MRB_Reset line in U1	Antonio Quiroz
B1	15-Aug-11	1. USB2SER always ON	Antonio Quiroz
B2	7-Sep-11	1. Rename SW1, SW2, SW4 and SWS with they correct Net Alias 2. Added TP17, TP18, TP19, U 3. Rename D4, D5, D9 and D10	Antonio Quiroz
B3	5-Jan-12	1. TP20, TP21 and TP22 were added	Ricardo Silva
B4	3-Feb-12	1. Layout Silkscreen 2. Rename J6 3. Replaced name X-RF-TWR with TWR-RF	Antonio Quiroz
C	5-Jun-12	1. Tx/Rx from UART0 to UART1 Change on TWR-Primary Elevator.	Antonio Quiroz

freescale semiconductor		Wireless Connectivity Operation	
This document contains information proprietary to Freescale Semiconductor and shall not be used for engineering design, procurement or manufacture in whole or in part without the express written permission of Freescale Semiconductor.		6501 William Cannon Drive West Austin, TX 78726-6998	
Designer: Antonio Quiroz	Drawing Title: <b>TWR-RF</b>	ICAP Classification: FGP_X	F3/QC_PURE
Drawn by: Ricardo Silva	Page Title: <b>TITLE PAGE</b>		
Approved: Jairo Muñoz	Size: C	Document Number: SCH-27107 PDF: SPF-27107	Rev: C
Date: Tuesday, June 05, 2012	Sheet 1 of 5		

Figure 6. Schematic Revision History

# 4.1 Schematic Rev B4

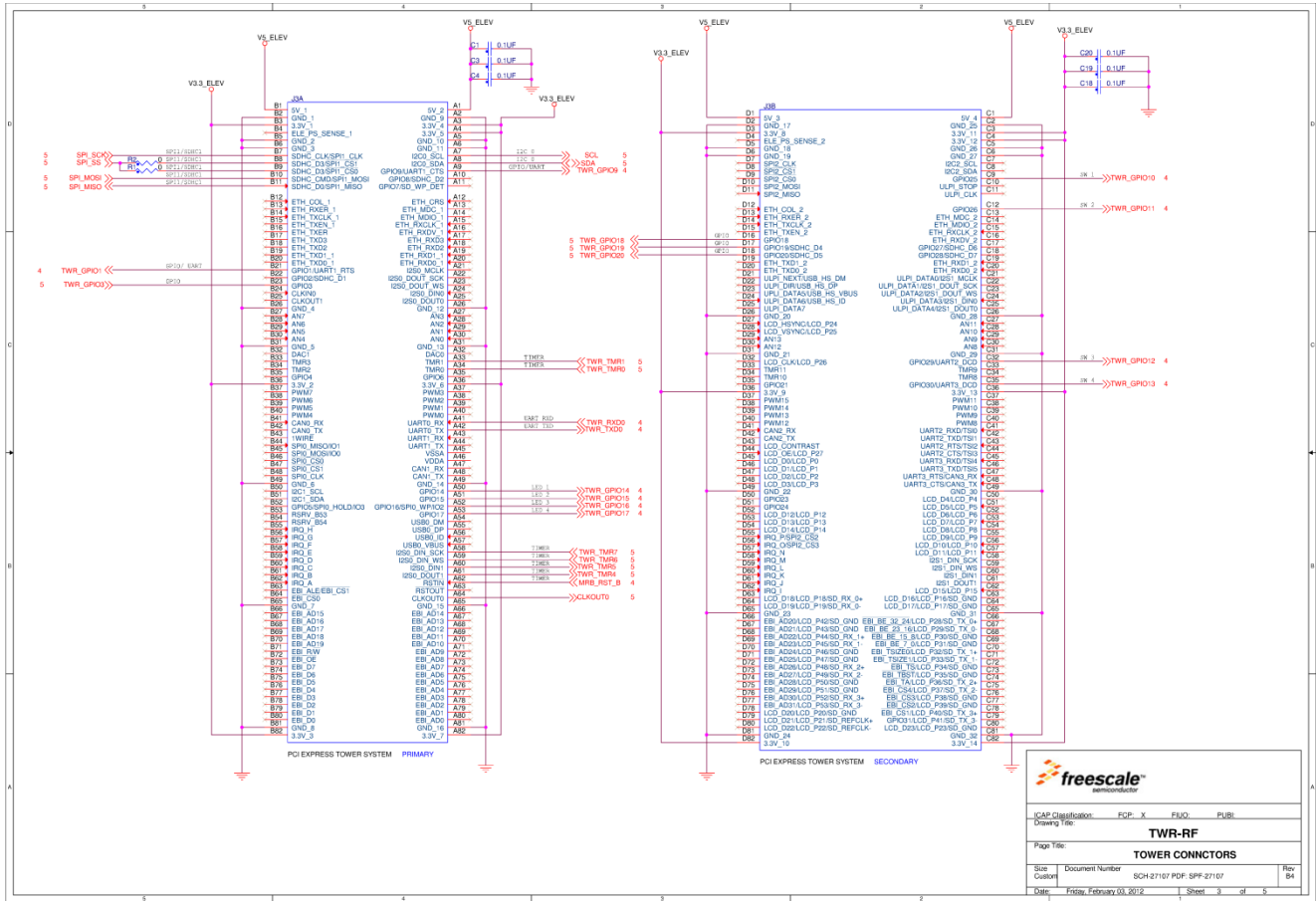

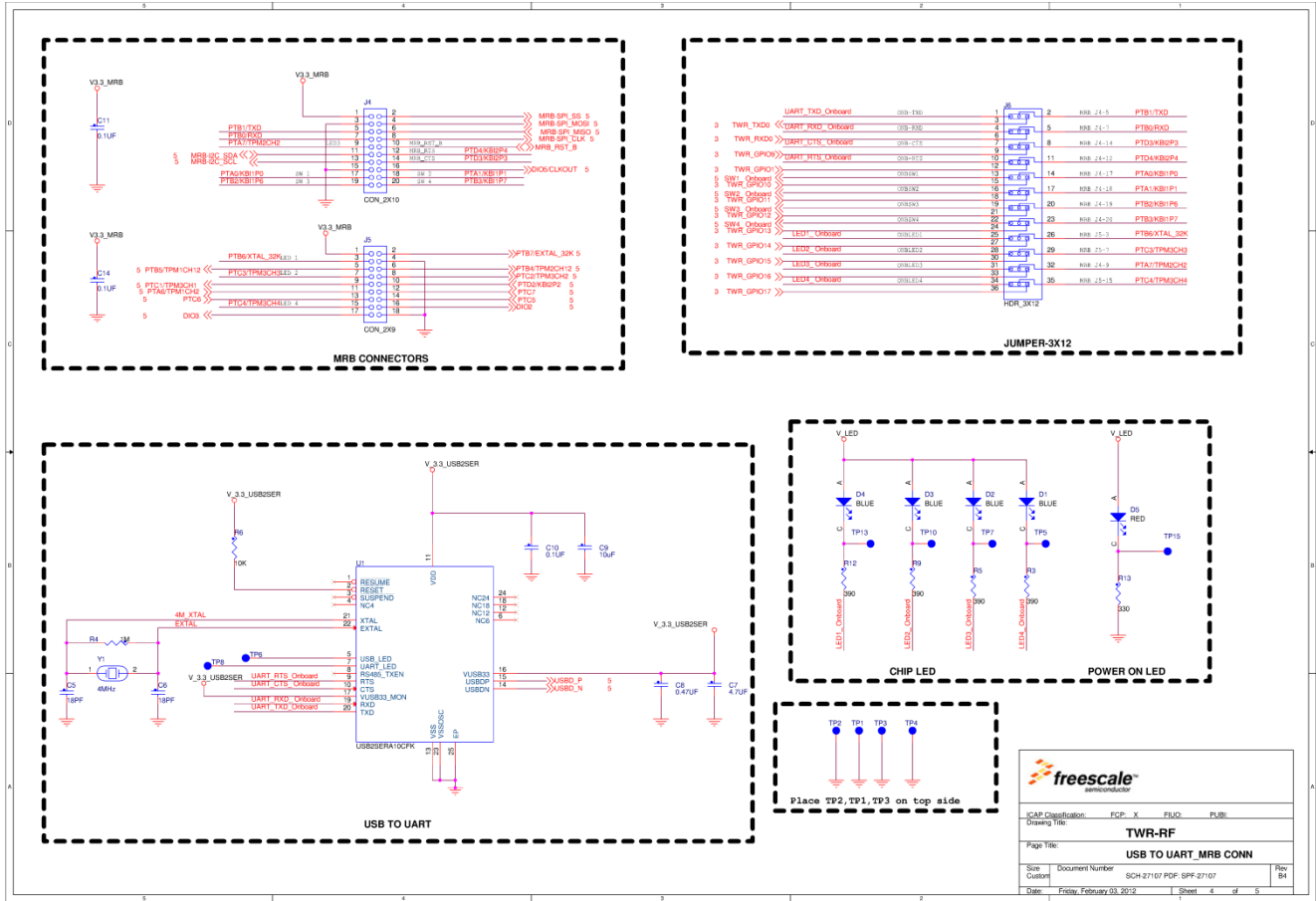

ICAP Classification: FCP: X    FW:    FL:R			
Drawing Title: <b>TWR-RF</b>			
Page Title: <b>USB TO UART_MRБ CONN</b>			
Site:	Document Number:	SCH-27101 PDP-69F-27101	
Custom:			Rev: 01
Date:	Friday, February 03, 2012	Sheet:	4 of 5

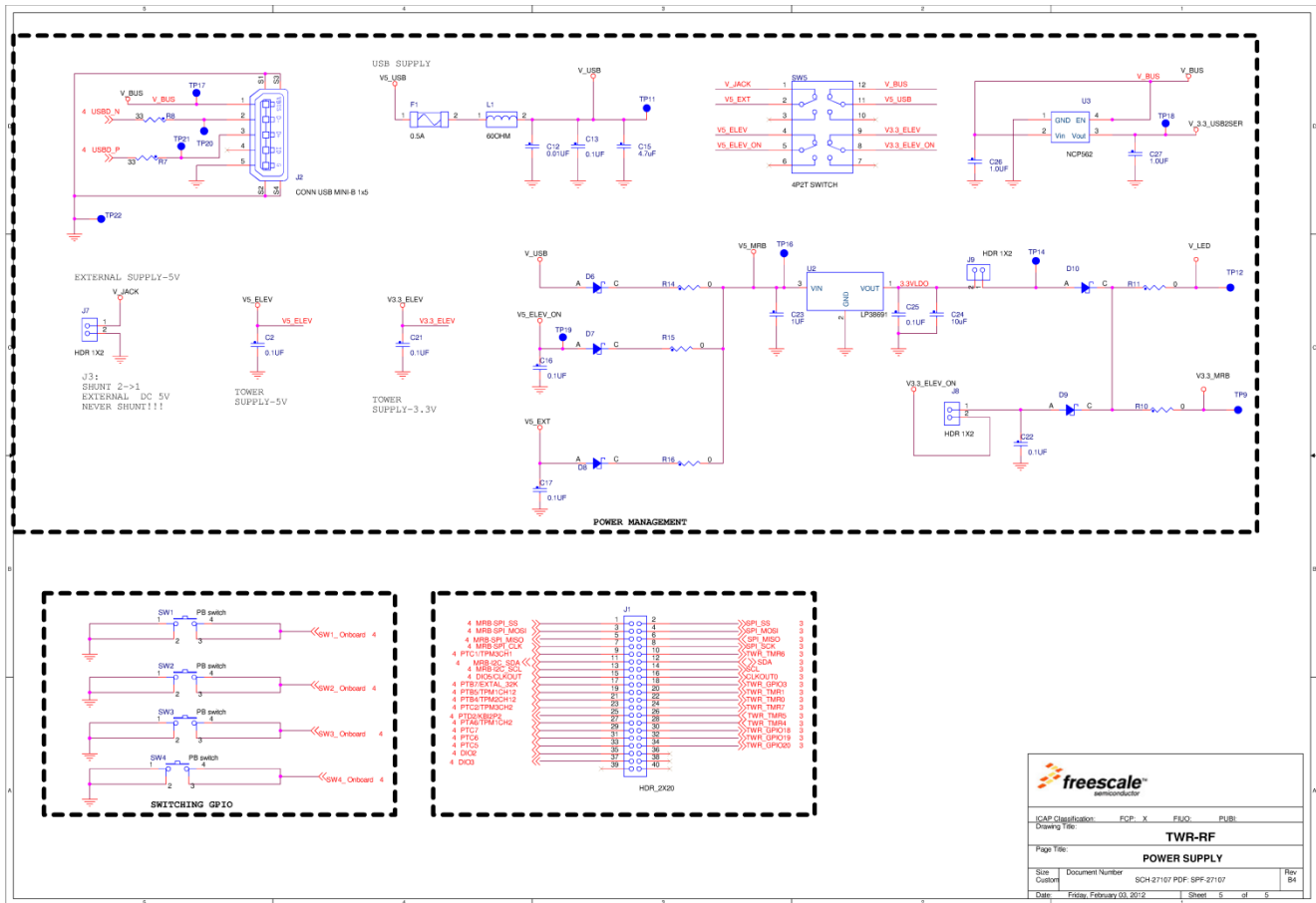

**freescale**  
semiconductor

Doc Classification: FOP, X, FUC, PUBI  
Drawing Title: **TWR-RF**

Page Title: **POWER SUPPLY**

Size: Custom | Document Number: 524-27107 PDF-SPF-27107 | Rev: B4  
Date: Friday, February 03, 2012 | Sheet: 5 of 5

# 4.2 Schematic Rev C

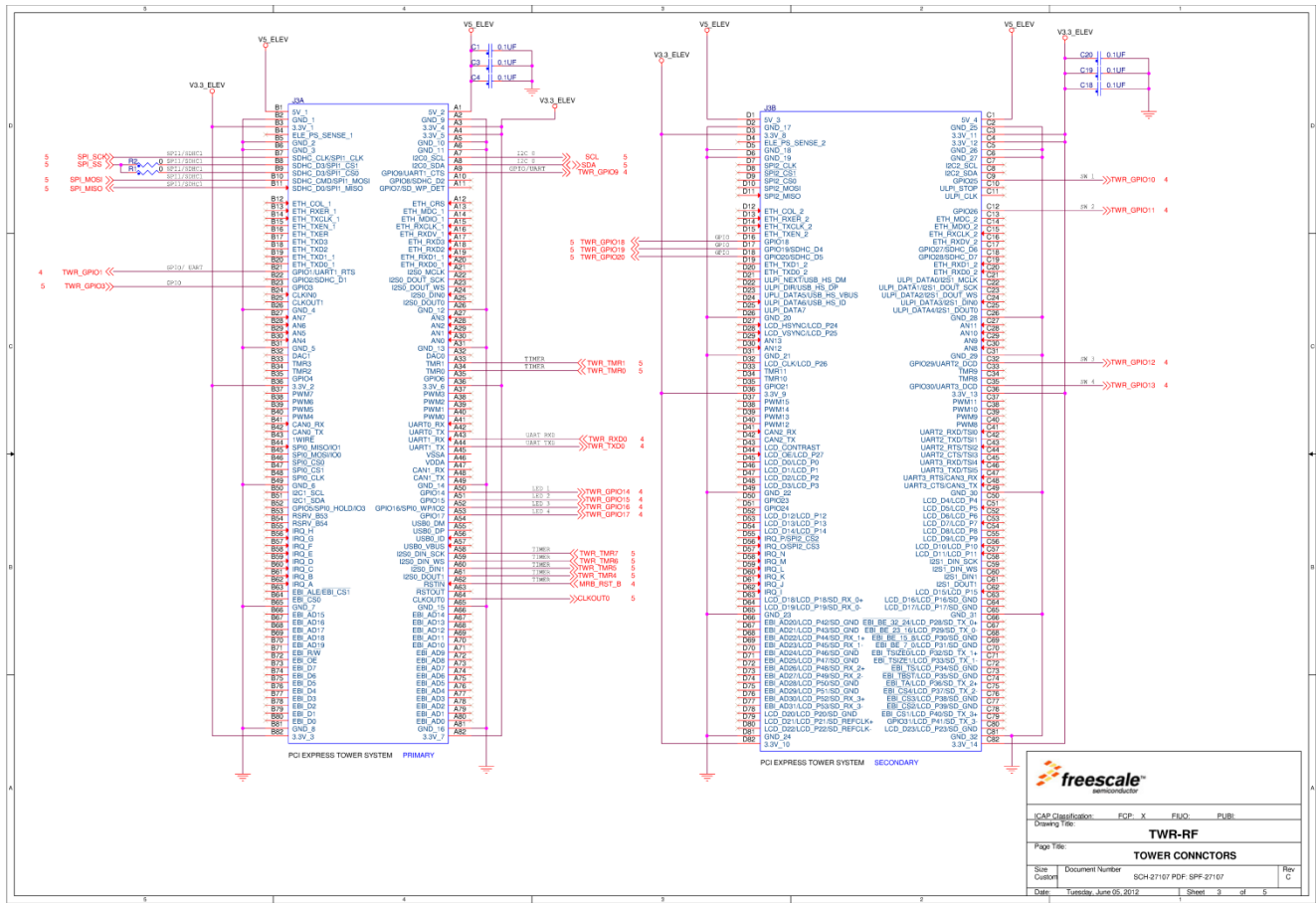

<b>freescale</b> semiconductor			
ICAP Classification:	FCCP	X	ESD
Document Number:	SCH-271107 PDF: SPF-271107		
Customer:	TWR-RF		
Date:	Tuesday, June 05, 2012		
Page 156:	<b>TOWER CONNECTORS</b>		
Sheet:	1	of	5

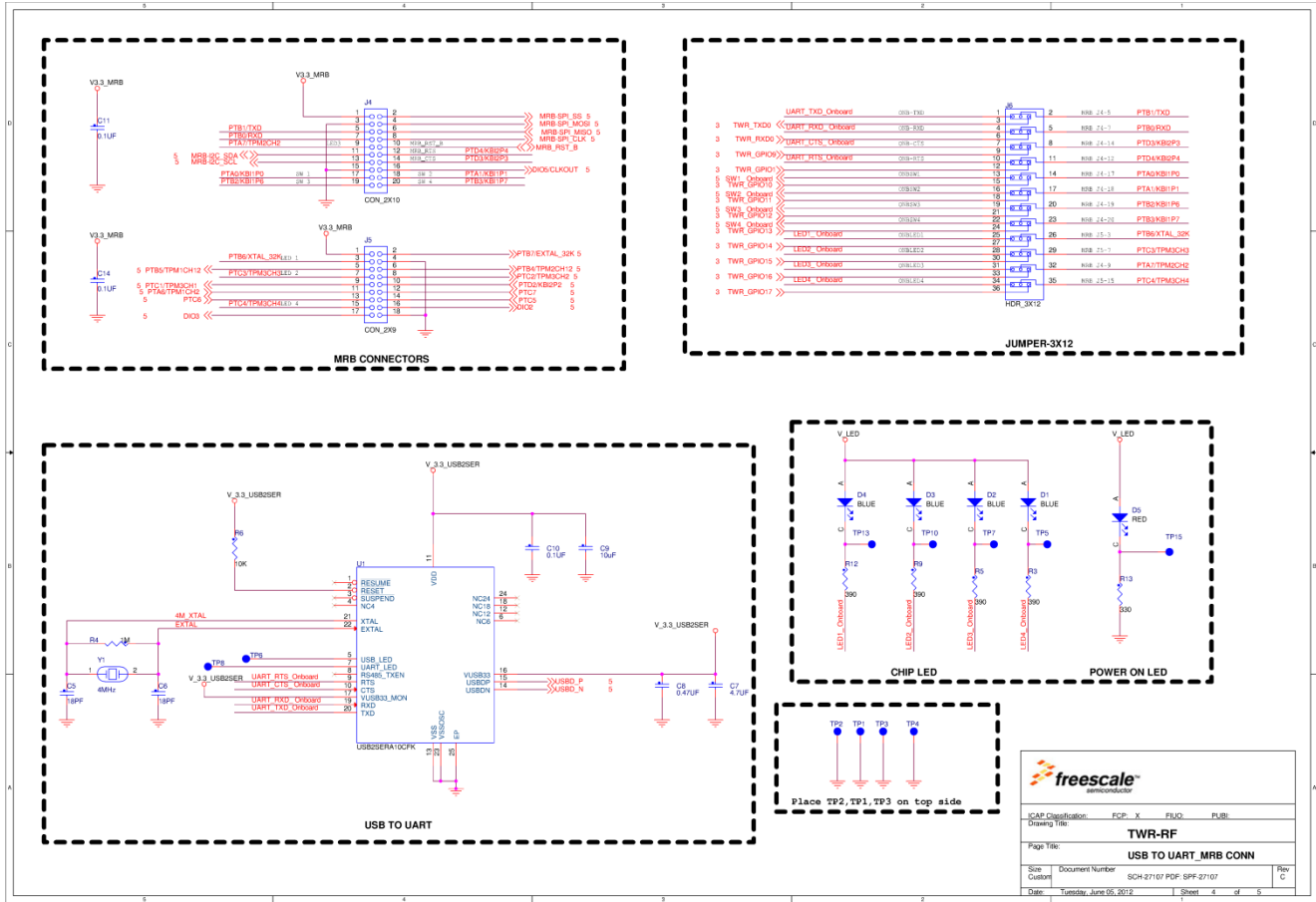

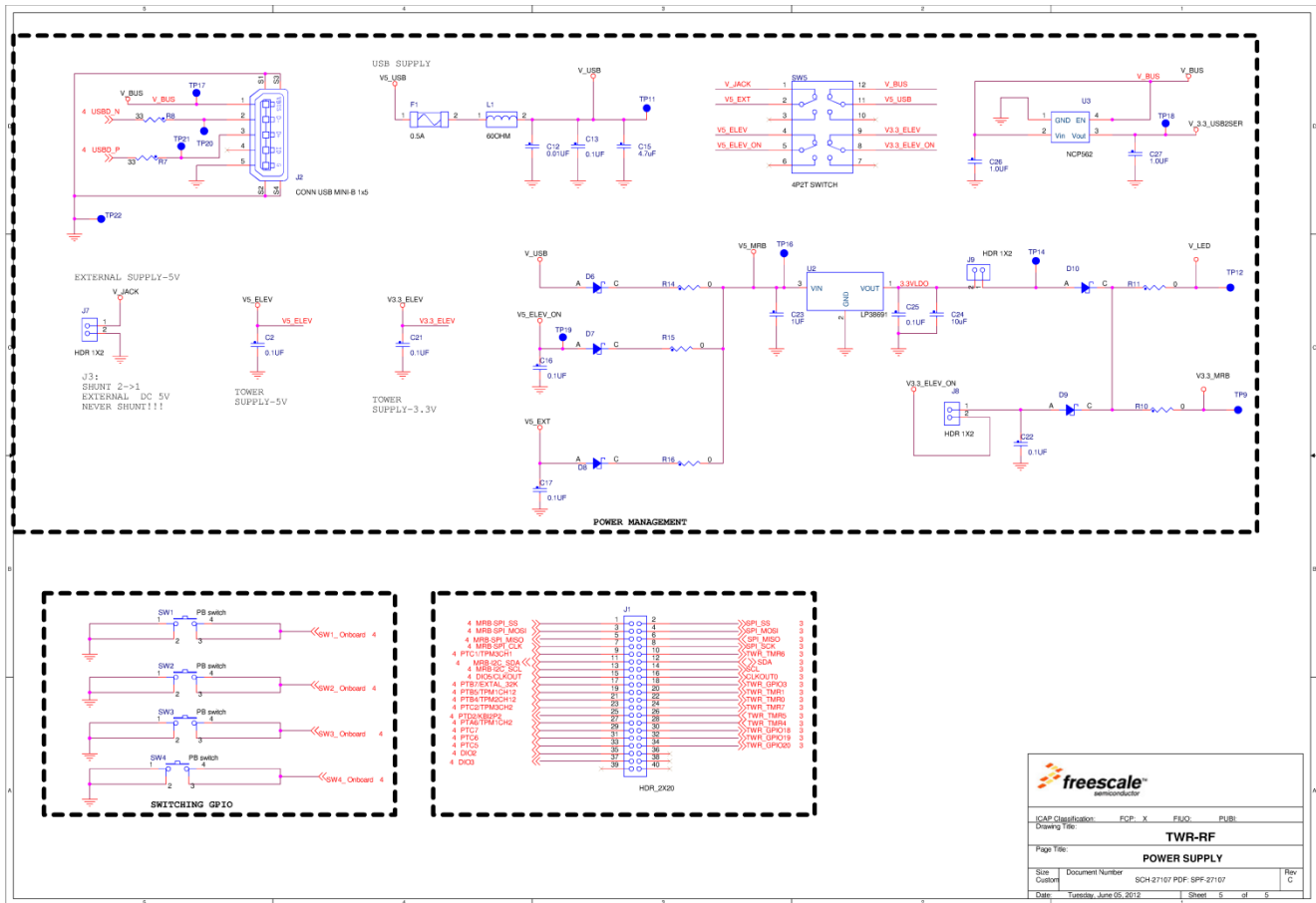



---

**How to Reach Us:**

**Home Page:**

[freescale.com](http://freescale.com)

**Web Support:**

[freescale.com/support](http://freescale.com/support)

Information in this document is provided solely to enable system and software implementers to use Freescale products. There are no express or implied copyright licenses granted hereunder to design or fabricate any integrated circuits based on the information in this document.

Freescale reserves the right to make changes without further notice to any products herein. Freescale makes no warranty, representation, or guarantee regarding the suitability of its products for any particular purpose, nor does Freescale assume any liability arising out of the application or use of any product or circuit, and specifically disclaims any and all liability, including without limitation consequential or incidental damages. "Typical" parameters that may be provided in Freescale data sheets and/or specifications can and do vary in different applications, and actual performance may vary over time. All operating parameters, including "typicals," must be validated for each customer application by customer's technical experts. Freescale does not convey any license under its patent rights nor the rights of others. Freescale sells products pursuant to standard terms and conditions of sale, which can be found at the following address: [freescale.com/SalesTermsandConditions](http://freescale.com/SalesTermsandConditions).

Freescale and the Freescale logo are trademarks of Freescale Semiconductor, Inc., Reg. U.S. Pat. & Tm. Off. Toweris a trademark of Freescale Semiconductor, Inc. All other product or service names are the property of their respective owners.

© 2014 Freescale Semiconductor, Inc.

Document Number: TWRRFRM

Rev. 4.0

02/2014

