

for Automotive Applications

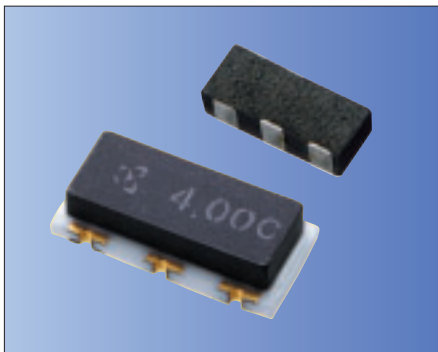

RoHS Compliant

Features

- Stable oscillation by using fundamental vibration in all frequencies
- Small & low profile
- Built-in capacitor structure
- Reflow solderable

Applications

- Automotive
- ABS
- ECU
- Air-Bag System

How to Order (PBRV-H,PBRV-M)

PBRV 15.00 H R 50 Y 000
 ① ② ③ ④ ⑤ ⑥ ⑦

- ① Series (PBRV: Automotive)
- ② Frequency (MHz)
- ③ Type (H, M)
- ④ Packing R: Tape & Reel
 PBRV-H (2000 pcs./ Reel)
 PBRV-M (3000 pcs./ Reel)
 (Null): Bulk
- ⑤ Frequency Tolerance at 25°C

10	±0.1%	20	±0.2%
30	±0.3%	40	±0.4%
50	±0.5%	70	±0.7%

- ⑥ Operating Temperature

X	-40°C to 85°C	Y	-40°C to 125°C
Z	-40°C to 150°C		

- ⑦ Unique Code

How to Order (PRQV)

PRQV 8.00 C R 50 10 Y 000
 ① ② ③ ④ ⑤ ⑥ ⑦ ⑧

- ① Series (PRQV: Automotive)
- ② Frequency (MHz)
- ③ Type (C)
- ④ Packing R: Tape & Reel (3000 pcs./ Reel)
 (Null): Bulk
- ⑤ Frequency Tolerance at 25°C

30	±0.3%	40	±0.4%
50	±0.5%	70	±0.7%

- ⑥ Built-in Capacitance 10pF: 10 5pF: 05

- ⑦ Operating Temperature

X	-40°C to 85°C	Y	-40°C to 125°C
Z	-40°C to 150°C		

- ⑧ Unique Code

Specifications

Series	Frequency Range (MHz)	Frequency Tolerance (25°C)	Temperature Stability	Operating Temperature Range (°C)
PBRV-HR	2.0 to 8.0	±0.50%	±0.30%	-40 to 125
	8.1 to 20.0	±0.50%	±0.10%	-40 to 125
PBRV-MR	8.0 to 20.0	±0.50%	±0.10%	-40 to 125
	4.0 to 10.0	±0.50%	±0.30%	-40 to 125
PRQV	8.0 to 20.0	±0.50%	±0.50%	-40 to 125

* Please contact us for products without built-in capacitors.

Note)

- This product includes built-in capacitors, but values may not be the most appropriate depending on IC's.
- Evaluation of circuit with IC is necessary. IC circuit matching may be referenced with
 - 1) IC data books
 - 2) List of Recommended circuits in Kyocera website.
- Please contact IC manufacturer or Kyocera when there are difficulties in finding recommended circuits.

Test Circuit

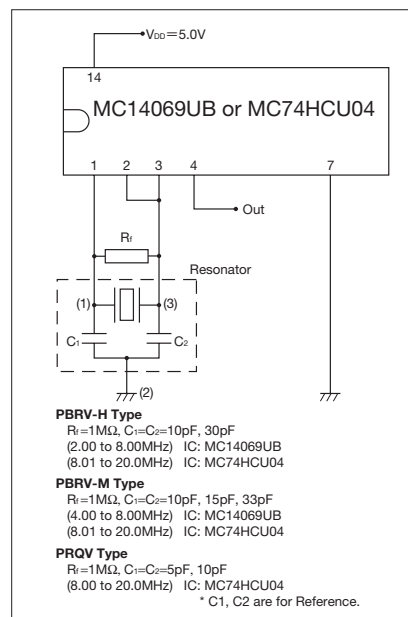

Dimensions

(Unit: mm)

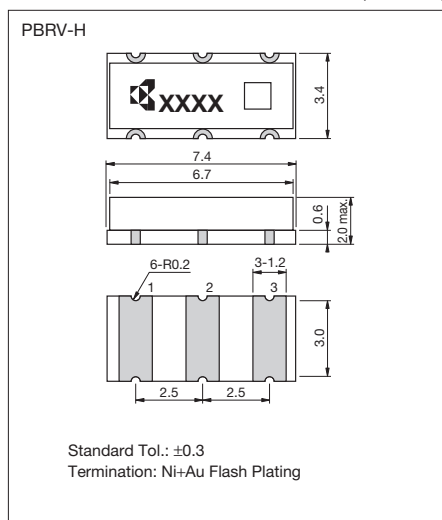

(Unit: mm)

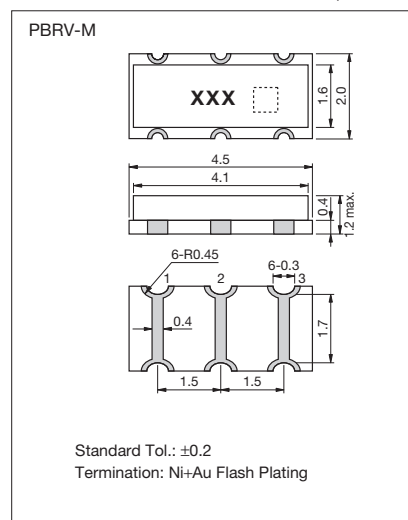

(Unit: mm)

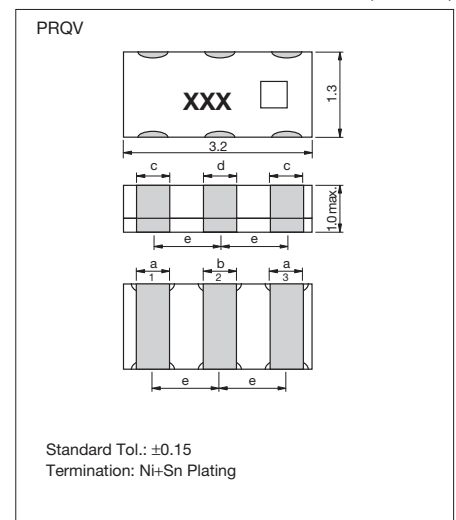

(Unit: mm)

Type	Frequency (MHz)	a	b	c	d	e
C	8.00 to 20.00	0.4	0.4	0.6	0.4	1.2



MHz Band Ceramic Chip Resonators (SMD) PBRV/ PRQV Frequency Tight Tolerance Series



for Automotive Applications

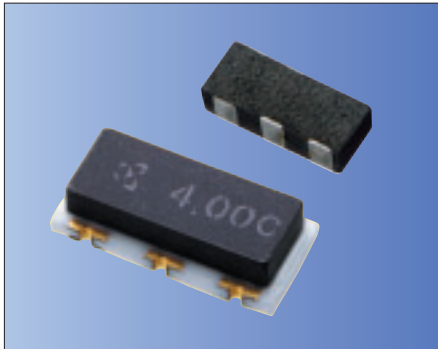

RoHS Compliant

Features

- Improved frequency tolerance suitable for CAN-BUS application
- The series are high accuracy resonators whose total tolerance is available for less than ± 3000 ppm

How to Order (PBRV)

PBRV 15.00 H R 10 Y 000
① ② ③ ④ ⑤ ⑥ ⑦

- Series (PBRV: Automotive)
- Frequency (MHz)
- Type (H, M)
- Packing R: Tape & Reel
PBRV-H (2000 pcs./ Reel)
PBRV-M (3000 pcs./ Reel)
(Null): Bulk
- Frequency Tolerance at 25°C

10 $\pm 0.1\%$

- Operating Temperature

X -40°C to 85°C Y -40°C to 125°C
Z -40°C to 150°C

- Unique Code

How to Order (PRQV)

PRQV 8.00 C R 15 10 Y 000
① ② ③ ④ ⑤ ⑥ ⑦ ⑧

- Series (PRQV: Automotive)
- Frequency (MHz)
- Type (C)
- Packing R: Tape & Reel (3000 pcs./ Reel)
(Null): Bulk
- Frequency Tolerance at 25°C

15 $\pm 0.15\%$

- Built-in Capacitance 10pF: 10 5pF: 05

- Operating Temperature

X -40°C to 85°C Y -40°C to 125°C
Z -40°C to 150°C

- Unique Code

Specifications

Series	Frequency Range (MHz)	Frequency Tolerance Initial + Temperature	Operating Temperature Range (°C)
PBRV-HR	2.0 to 20.0	$\pm 0.25\%$	-40 to 125
PBRV-MR	4.0 to 20.0	$\pm 0.25\%$	-40 to 125
PRQV	8.0 to 20.0	$\pm 0.25\%$	-40 to 125

* Please refer to the specification sheet of each product for information including detail dimensions.

Test Circuit

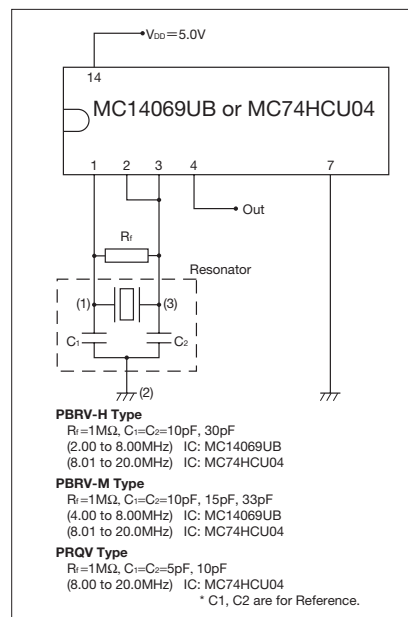

Dimensions

(Unit: mm)

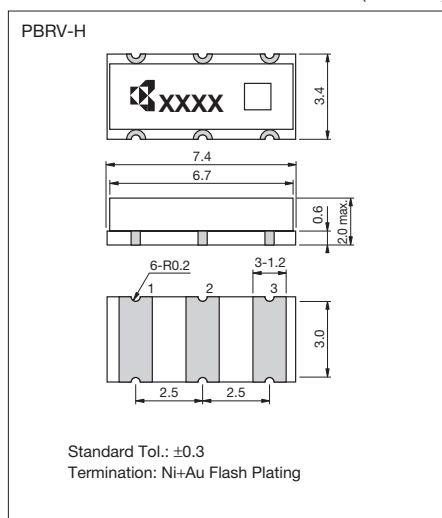

(Unit: mm)

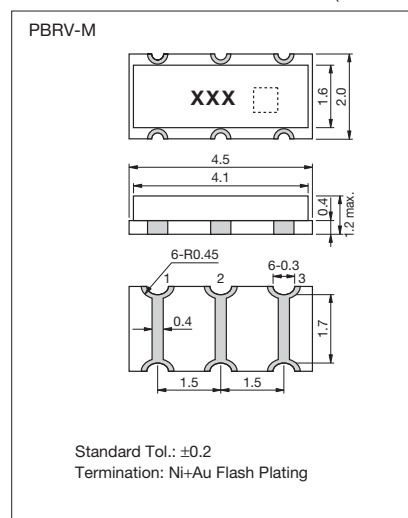

(Unit: mm)

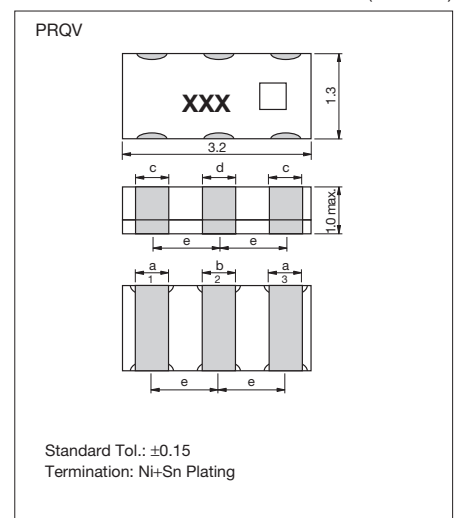

(Unit: mm)

Type	Frequency (MHz)	a	b	c	d	e
C	8.00 to 20.00	0.4	0.4	0.6	0.4	1.2

for Consumer Applications

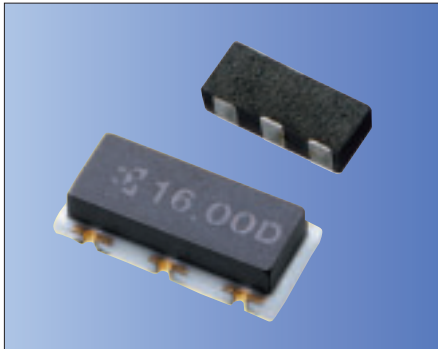

RoHS Compliant

Features

- Stable oscillation by using fundamental vibration in all frequencies
- Small & low profile
- Built-in capacitor structure
- Reflow solderable

How to Order (PBRC-H, PBRC-M)

PBRC 15.00 H R 50 X 000
① ② ③ ④ ⑤ ⑥ ⑦

- ① Series
- ② Frequency (MHz)
- ③ Type (H, M)
- ④ Packing R: Tape & Reel
PBRC-H (2000 pcs./ Reel)
PBRC-M (3000 pcs./ Reel)
(Null): Bulk
- ⑤ Frequency Tolerance at 25°C

10	±0.1%	20	±0.2%
30	±0.3%	40	±0.4%
50	±0.5%	70	±0.7%

- ⑥ Operating Temperature

X -40°C to 85°C

- ⑦ Unique Code

How to Order (PRQC)

PRQC 8.00 C R 50 10 X 000
① ② ③ ④ ⑤ ⑥ ⑦ ⑧

- ① Series
- ② Frequency (MHz)
- ③ Type (C, S)
- ④ Packing R: Tape & Reel (3000 pcs./ Reel)
(Null): Bulk
- ⑤ Frequency Tolerance at 25°C

30	±0.3%	40	±0.4%
50	±0.5%	70	±0.7%

- ⑥ Built-in Capacitance 10pF: 10 5pF: 05

- ⑦ Operating Temperature

W -20°C to 80°C **X** -40°C to 85°C

- ⑧ Unique Code

Specifications

Series	Frequency Range (MHz)	Frequency Tolerance (25°C)	Temperature Stability	Operating Temperature Range (°C)
PBRC-HR	2.0 to 8.0	±0.50%	±0.30%	-40 to 85
	8.1 to 20.0	±0.50%	±0.10%	-40 to 85
PBRC-MR	8.0 to 20.0	±0.50%	±0.10%	-40 to 85
	4.0 to 10.0	±0.50%	±0.30%	-40 to 85
PRQC	4.0 to 10.0	±0.50%	±0.30%	-40 to 85
	10.1 to 20.0	±0.50%	±0.50%	-40 to 85
PRQC	8.0 to 20.0	±0.50%	±0.50%	-40 to 85

Test Circuit

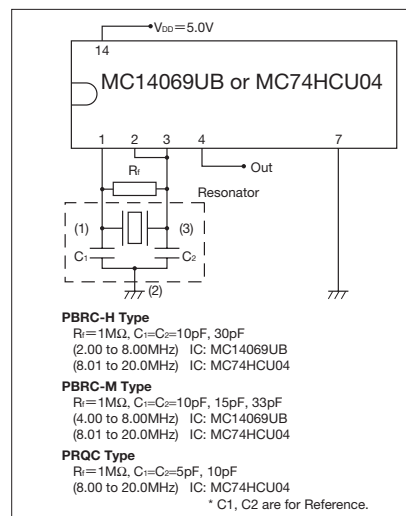

Note)

- This product includes built-in capacitors, but values may not be the most appropriate depending on IC's.
- Evaluation of circuit with IC is necessary. IC circuit matching may be referenced with
 - 1) IC data books
 - 2) List of Recommended circuits in Kyocera website.
- Please contact IC manufacturer or Kyocera when there are difficulties in finding recommended circuits.

Dimensions

(Unit: mm)

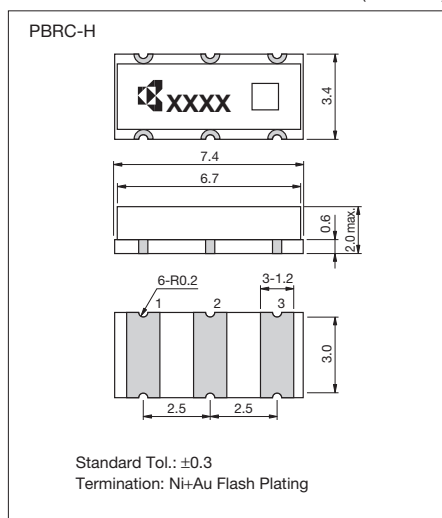

(Unit: mm)

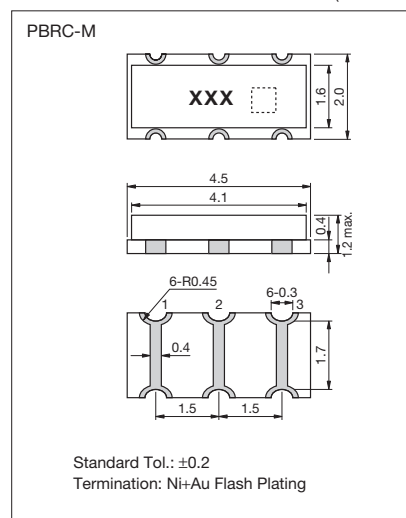

(Unit: mm)

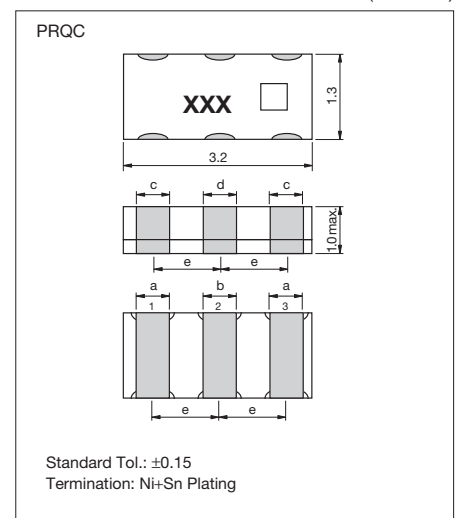

(Unit: mm)

Type	Frequency (MHz)	a	b	c	d	e
C	8.00 to 20.00	0.4	0.4	0.6	0.4	1.2
S	14.00 to 20.00	0.6	0.4	0.6	0.4	0.95

for Consumer Applications



RoHS Compliant

Features

- Stable oscillation by using fundamental vibration in all frequencies
- Small & low profile
- Reflow solderable

How to Order

PBRC 8.00 G R 50 X 000
 ① ② ③ ④ ⑤ ⑥ ⑦

- ① Series
- ② Frequency (MHz)
- ③ Type (G)
- ④ Packing R: Tape & Reel (2000 pcs./ Reel)
(Null): Bulk
- ⑤ Frequency Tolerance at 25°C

10	±0.1%	20	±0.2%
30	±0.3%	40	±0.4%
50	±0.5%		

- ⑥ Operating Temperature

X	-40°C to 85°C
---	---------------

- ⑦ Unique Code

Specifications

Series	Frequency Range (MHz)	Frequency Tolerance (25°C)	Temperature Stability	Operating Temperature Range (°C)
PBRC-GR	2.0 to 8.0	±0.50%	±0.50%	-40 to 85

Test Circuit

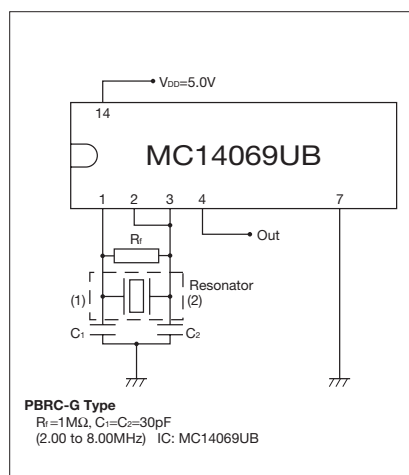

Note)

- Values of C_1 , C_2 and R_f are evaluated with IC, MC14069UB, and evaluation of circuit is necessary when using other IC's.
- IC circuit matching may be referenced with
 - 1) IC data books
 - 2) List of Recommended circuits in Kyocera website.
- Please contact IC manufacturer or Kyocera when there are difficulties in finding recommended circuits.

Dimensions

(Unit: mm)

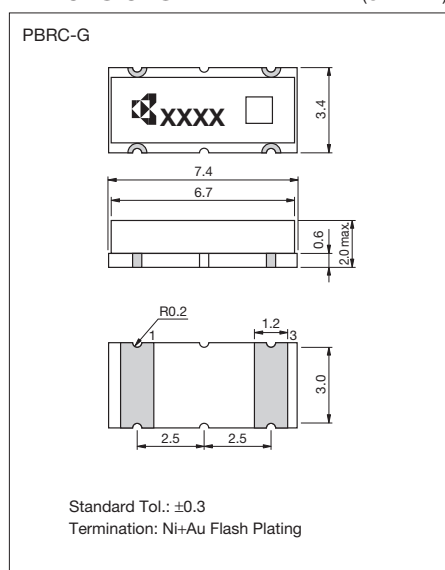

Recommended Land Pattern

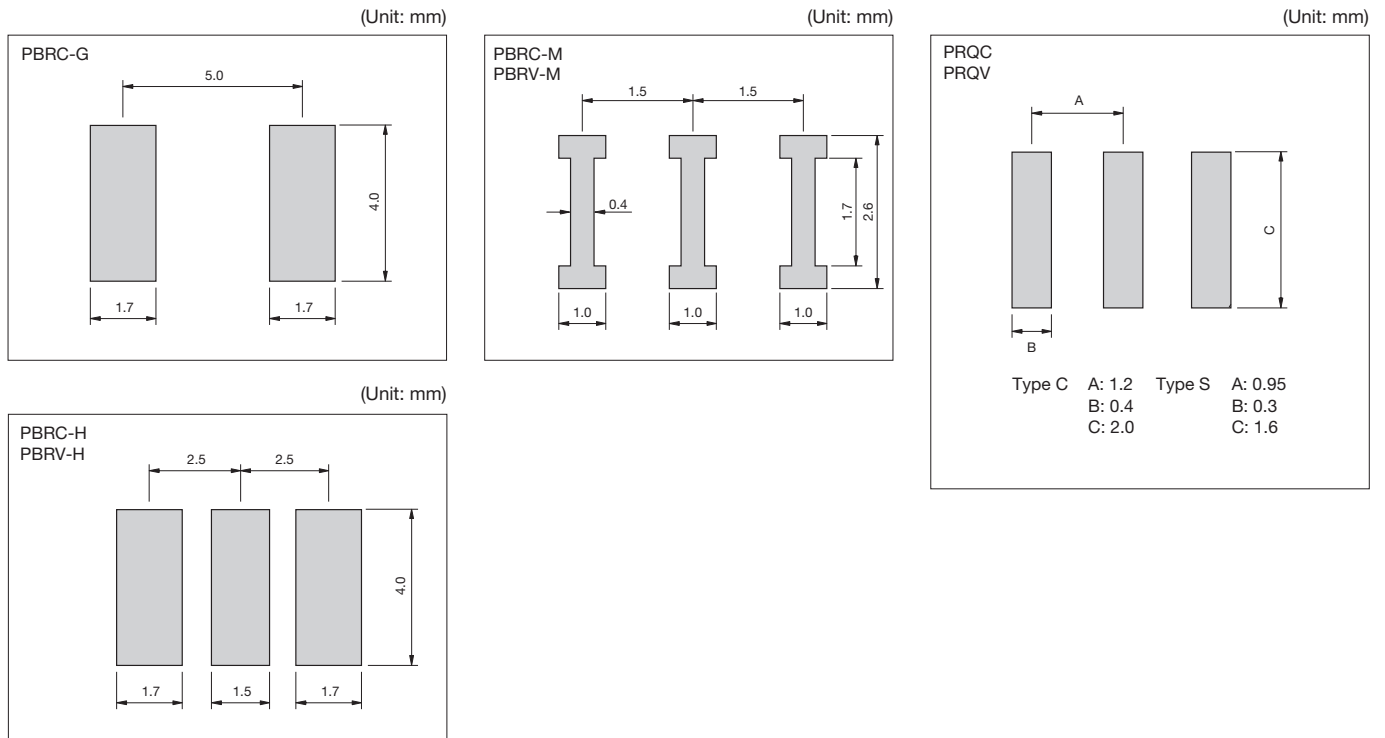

Packaging

Reel

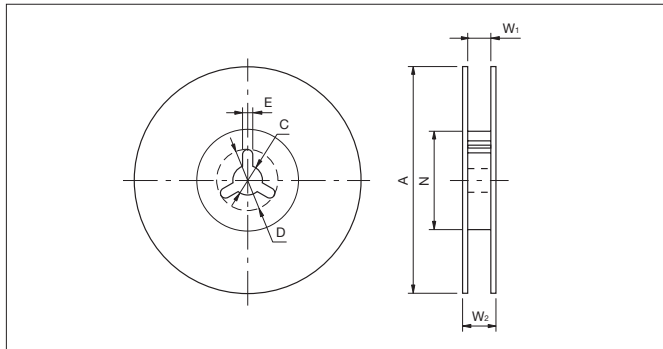

Taping

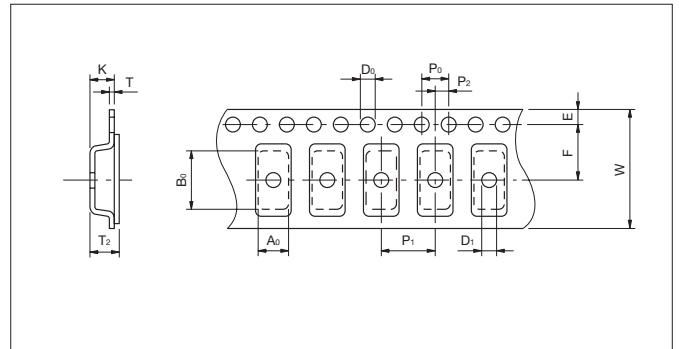

Code	A	N	W ₁	W ₂	C	D	E
7.4×3.4×2.0mm	250±2.0	80±2.0	16.5 ^{+1.1} _{-0.0}	23.6 max.	13.0±0.5	21.0±0.8	2.0±0.5
4.5×2.0×1.2mm	180 ⁺⁰ ₋₃	60 ⁺¹ ₋₀	13.0±0.3	15.4±1	13.0±0.2	21.0±0.8	2.0±0.5
3.2×1.3×1.3mm	180 ⁺⁰ ₋₉	50 min	9.0±0.3	12.4 max.	13.0±0.5	21.0±0.8	2.0±0.5

Code	A ₀	B ₀	W	F	E	P ₁	P ₂	P ₀	D ₀	D ₁	T	T ₂	K
7.4×3.4×2.0mm	3.80±0.1	7.80±0.1	16.00±0.3	7.50±0.1	1.75±0.1	8.00±0.1	2.0±0.1	4.00±0.1	1.50 ^{+0.1} _{-0.0}	1.50 ^{+0.1} _{-0.0}	0.30±0.05	2.45±0.2	2.40±0.2
4.5×2.0×1.2mm	2.20±0.1	4.70±0.1	12.00±0.2	5.5±0.05	1.75±0.1	4.00±0.1	2.0±0.05	4.00±0.1	1.50 ^{+0.1} _{-0.0}	1.0±0.1	0.30±0.05	1.85 max.	1.80 max.
3.2×1.3×1.3mm	1.50±0.2	3.45±0.2	8.00±0.3	3.50±0.05	1.75±0.1	4.00±0.1	2.0±0.05	4.00±0.1	1.50 ^{+0.1} _{-0.0}	1.0 ^{+0.1} _{-0.0}	0.25±0.05	1.40 max.	1.10±0.2