

NEMA line Outlet 5-15R, Snap-in Mounting, Front Side, Solder Terminal



Snap-In Version



Description

- Panel Mount:
Snap-in, Front Side
- 1 Function:
Line Outlet, Protection class II
- Solder

Approvals

- UL File Number: E103791
- CSA File Number: 73165

Characteristics

- Designed for standard applications

References

Alternative: Version in protection class I 0709

Weblinks

pdf-datasheet, html-datasheet, General Product Information, Approvals, CE declaration of conformity, RoHS, CHINA-RoHS, Mating Connectors, e-Shop, SCHURTER-Stock-Check, Distributor-Stock-Check, CAD-Drawings, Accessories, Detailed request for product

Technical Data

Ratings IEC	15 A / 250VAC; Hz
Ratings UL/CSA	15 A / 125VAC; 60Hz
Allowable Operation Temp.	-40 °C to 60 °C
Degree of Protection	from front side IP 20 acc. to IEC 60529
Protection Class	Suitable for appliances with protection class II acc. to IEC 61140
Terminal	Solder terminals
Panel Thickness s	Snap-in 0.8 mm to 1.5 mm
Material: Housing	Thermoplastic, black

Dimensions

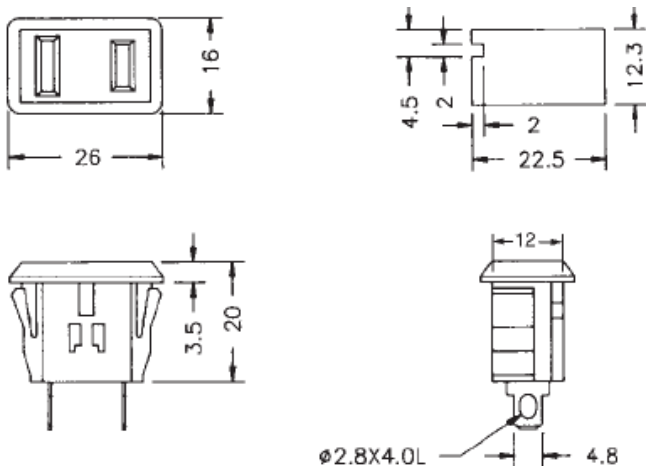

All Variants

Type	Protection Class	Panel mounting	Panel Thickness s [mm]	Terminal	Order Number
0715	II	Snap-in	0.8 to 1.5	Solder	4300.0705

Availability for all products can be searched real-time: <http://www.schurter.com/en/Stock-Check/Stock-Check-SCHURTER>

Packaging unit 200 Pcs

Mating Inlets/Plugs

Category / Description



[Power Supply or Interconnection Cord Overview complete](#)

[Diverse Power Supply and Interconnection Cords 2.5 A](#)

CS01.0221.150

[Diverse Power Supply and Interconnection Cords 2.5 A](#)

CS02.0221.150

[Power Supply or Interconnection Cord further types to 0715](#)
