

**PLEASE CHECK WWW.MOLEX.COM FOR LATEST PART INFORMATION**

**Part Number:** [50039-8000](#)  
**Status:** **Active**  
**Overview:** Mizu-P25™ Miniature Waterproof Connectors  
**Description:** 2.50mm Pitch Mizu-P25™ Crimp Terminal, 50039, Reel

**Documents:**

<a href="#">Drawing (PDF)</a>	<a href="#">Application Specification AS-50038-001 (PDF)</a>
<a href="#">Product Specification PS-52048-001 (PDF)</a>	<a href="#">Packaging Specification RPK-50039-901 (PDF)</a>
<a href="#">Product Specification PS-52117-008 (PDF)</a>	<a href="#">RoHS Certificate of Compliance (PDF)</a>

**General**

Product Family	Crimp Terminals
Series	<a href="#">50039</a>
Application	Signal
Crimp Quality Equipment	Yes
Overview	<a href="#">Mizu-P25™ Miniature Waterproof Connectors</a>
Packaging Alternative	<a href="#">50039-8100 (Loose)</a>
Product Name	Mizu-P25™ Waterproof
UPC	800754368681

**Physical**

Gender	Female
Material - Metal	Phosphor Bronze
Material - Plating Mating	Tin
Material - Plating Termination	Tin
Net Weight	60.500/mg
Packaging Type	Reel
Plating min - Mating	0.889µm
Plating min - Termination	0.914µm
Termination Interface: Style	Crimp or Compression
Wire Insulation Diameter	1.80-1.90mm
Wire Size AWG	20, 22
Wire Size mm²	N/A

**Electrical**

Voltage - Maximum	250V
-------------------	------

**Material Info**

**Reference - Drawing Numbers**

Application Specification	AS-50038-001
Packaging Specification	RPK-50039-901
Product Specification	PS-52048-001, PS-52117-008, RPS-52048-001
Sales Drawing	SD-50039-001

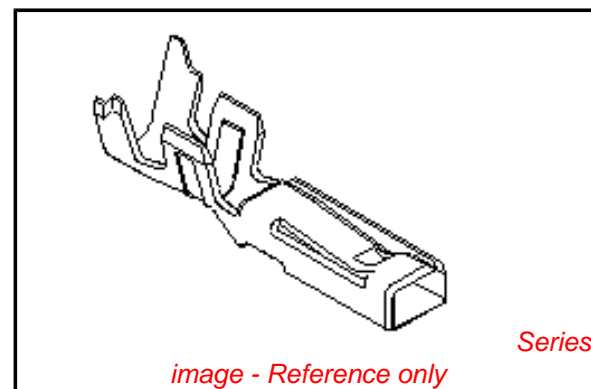

**EU RoHS**

**ELV and RoHS Compliant**  
**REACH SVHC**  
**Contains SVHC: No**  
**Low-Halogen Status**  
**Low-Halogen**

**China RoHS**



**Need more information on product environmental compliance?**

Email [productcompliance@molex.com](mailto:productcompliance@molex.com)  
 For a multiple part number RoHS Certificate of Compliance, [click here](#)

Please visit the [Contact Us](#) section for any non-product compliance questions.

**Search Parts in this Series**

[50039Series](#)

**Mates With**

[50038 2.50mm Pitch Mizu-P25™ Crimp Terminal](#)

**Use With**

[52117 Mizu-P25™ 2.50mm Pitch Waterproof Wire-to-Wire Receptacle Housing](#)

**Application Tooling | FAQ**

*Tooling specifications and manuals are found by selecting the products below. Crimp Height Specifications are then contained in the Application Tooling Specification document.*

**Global**

Description	Product #
Hand Crimp Tool for Splash Proof Crimp Terminal	<a href="#">0638233900</a>

FineAdjust™ Applicator for 2.50mm Pitch Splash Proof Crimp Terminal, 20-22 AWG	<u>0639000100</u>
T2 Terminator Tooling Die for 2.50mm Pitch Splash Proof Crimp Terminal, 20-22 AWG	<u>0639100100</u>
<b>Japan</b>	
<b>Description</b>	<b>Product #</b>
Applicator for M21 1A Bench Press	<u>0570843000</u>

This document was generated on 10/30/2013

**PLEASE CHECK [WWW.MOLEX.COM](http://WWW.MOLEX.COM) FOR LATEST PART INFORMATION**