

Small Hole Gage Set

SERIES 154

FEATURES

- Used with an outside micrometer for measuring inside diameter of bores.
- 4 sizes of gages are supplied in a fitted pouch.
- Extra long for gaging deep and shallow holes, slots, and similar workpieces.
- Gaging surface is fully hardened to insure long tool life.



154-901

DIMENSIONS

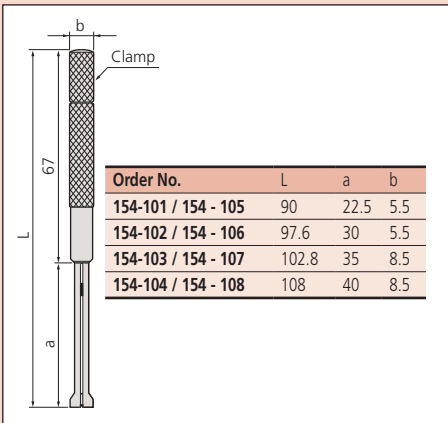

SPECIFICATIONS

| Metric | | |
|---------------------------|---------------|----------------------------|
| Total range | Set Order No. | Assortment of gages |
| ø3 - 13mm (4-gage set) | 154-902 | ø3 - 5mm gage (154-101) |
| | | ø5 - 7.5mm gage (154-102) |
| | | ø7.5 - 10mm gage (154-103) |
| | | ø10 - 13mm gage (154-104) |

| Inch | | |
|-------------------------------------|---------------|---------------------------------|
| Total range | Set Order No. | Assortment of gages |
| .125" - .5" DIA. (4-gage set) | 154-901 | .125" - .2" DIA. gage (154-105) |
| | | .2" - .3" DIA. gage (154-106) |
| | | .3" - .4" DIA. gage (154-107) |
| | | .4" - .5" DIA. gage (154-108) |

Telescoping Gage Set

SERIES 155

FEATURES

- Spring-loaded plunger expands within the bore (or groove), allowing determination of the internal diameter (or groove width).
- With a knurled clamp.
- Supplied in a fitted pouch.



155-903

DIMENSIONS

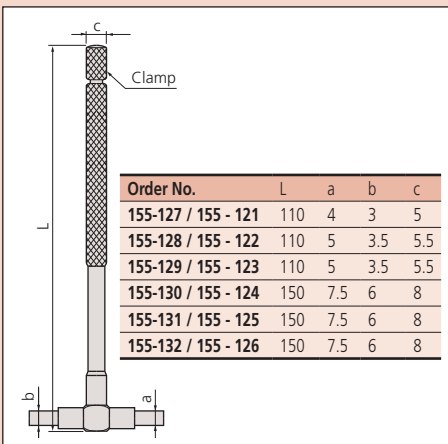

SPECIFICATIONS

| Metric | | |
|---------------------------|---------------|----------------------------|
| Total range | Set Order No. | Included in set |
| 8 - 150mm (6-gage set) | 155-905 | 8 - 12.7mm gage (155-127) |
| | | 12.7 - 19mm gage (155-128) |
| | | 19 - 32mm gage (155-129) |
| | | 32 - 54mm gage (155-130) |
| | | 54 - 90mm gage (155-131) |
| | | 90 - 150mm gage (155-132) |

| Inch | | |
|-------------------------------|---------------|---|
| Total range | Set Order No. | Included in set |
| .313 - 6" (6-gage set) | 155-903 | .313" - .5" gage (155-121) |
| | | .5" - .75" gage (155-122) |
| | | .75" - 1.25" gage (155-123) |
| | | 1.25" - 2.125" gage (155-124) |
| | | 2.125" - 3.5" gage (155-125) |
| | | 3.5" - 6" gage (155-126) |
| .50 - 6" (5-gage set) | 155-904 | 155-122, 155-123, 155-124, 155-125, 155-126 |
| .315 - 2.125" (4-gage set) | 155-907 | 155-121, 155-122, 155-123, 155-124 |