

Ultra compact and efficient 1-stage filter in ECO design for 3-phase systems



Description

- High attenuation value
- Cost optimized filter design with excellent price / performance ratio
- Very light due to partial potting

Standards

- IEC 60939
- UL 1283

Approvals

- VDE Certificate Number: pending
- UL File Number: pending

Applications

- Voltage rating 480 VAC for world wide acceptance
- Especially designed for industrial applications such as: Frequency Converters, Stepper Motor Drives, UPS-Systems, Inverters
- Suitable for use in equipment according to IEC/UL 60950

Weblinks

[pdf-datasheet](#), [html-datasheet](#), [General Product Information](#), [Approvals](#), [CE declaration of conformity](#), [RoHS](#), [CHINA-RoHS](#), [e-Shop](#), [SCHURTER-Stock-Check](#), [Distributor-Stock-Check](#), [Detailed request for product](#)

Technical Data

Rated Current	16 - 150A @ Ta 40°C
Rated voltage	480VAC, 50/60 Hz
Approval for	16 - 150A @ Ta 40 °C / 480VAC; 50/60Hz
Overload Current	1.5 x Ir
Leakage Current	< 33mA (440V / 50Hz)
Dielectric Strength	480VAC: > 2.25kVDC between L-L > 3kVDC between L-PE Test voltage 2 sec
Number of Filter Stages	1-stage
Weight	1 - 7kg
Material: Housing	Aluminum
Sealing Compound	UL 94V-0

Mounting	Screw-on mounting on chassis, upright or lengthwise
Terminal	Bolts and nuts
Operating Temperature [°C]	-25°C to 100°C
Climatic Category	25/100/21 acc. to IEC 60068-1
Degree of Protection	IP 20 acc. to IEC 60529
Protection Class	Suitable for appliances with protection class I acc. to IEC 61140
MTBF	> 200'000h acc. to MIL-HB-217 F

Dimension

Case 1C

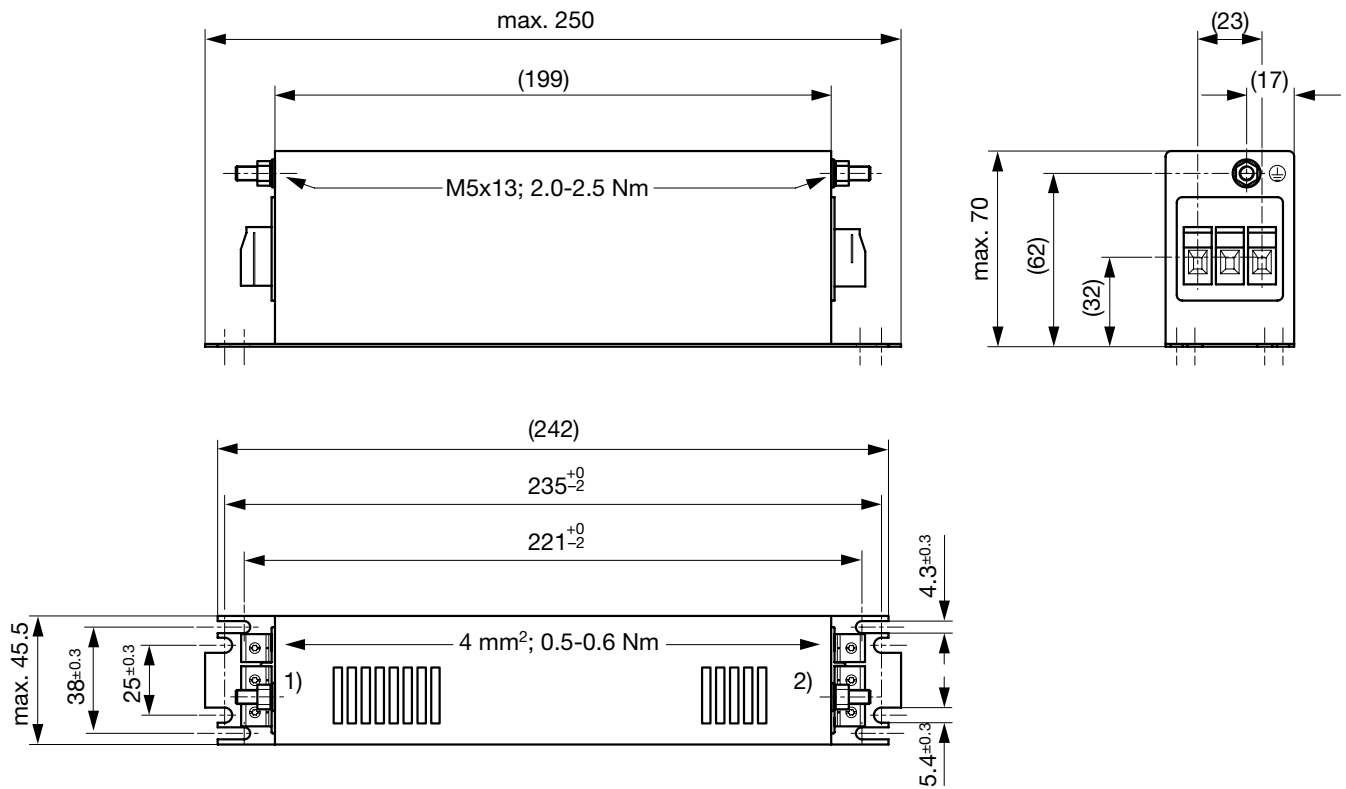

- 1) Line
- 2) Load

Case 1D-6

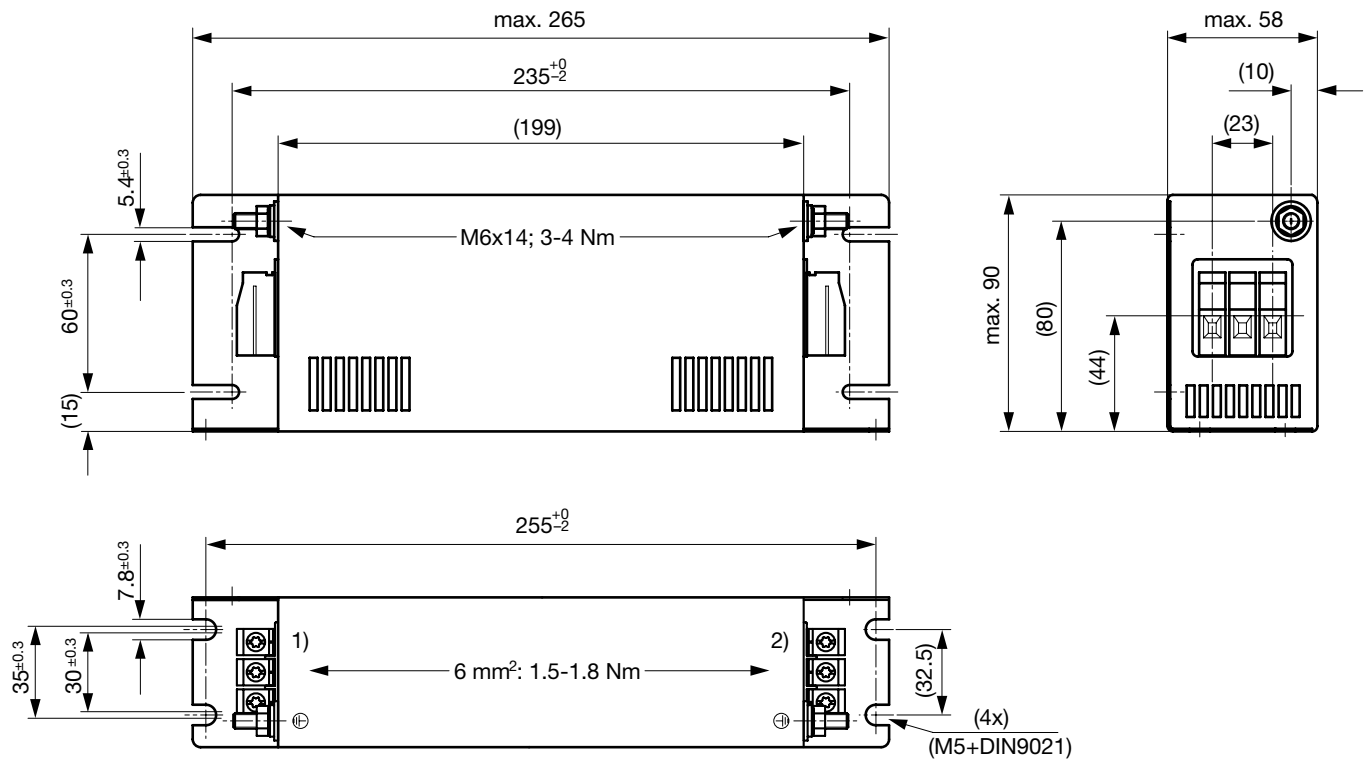

- 1) Line
- 2) Load

Case 1D-10

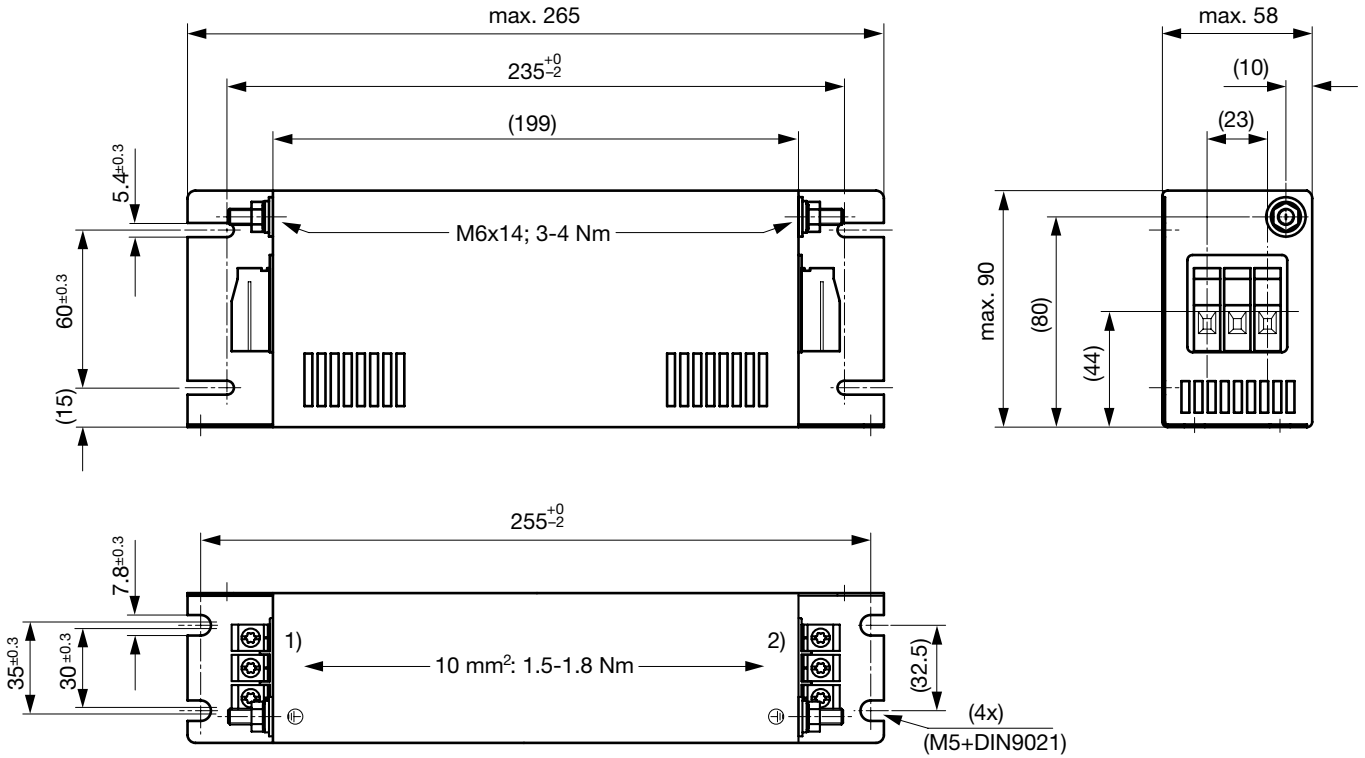

- 1) Line
- 2) Load

Case 1E

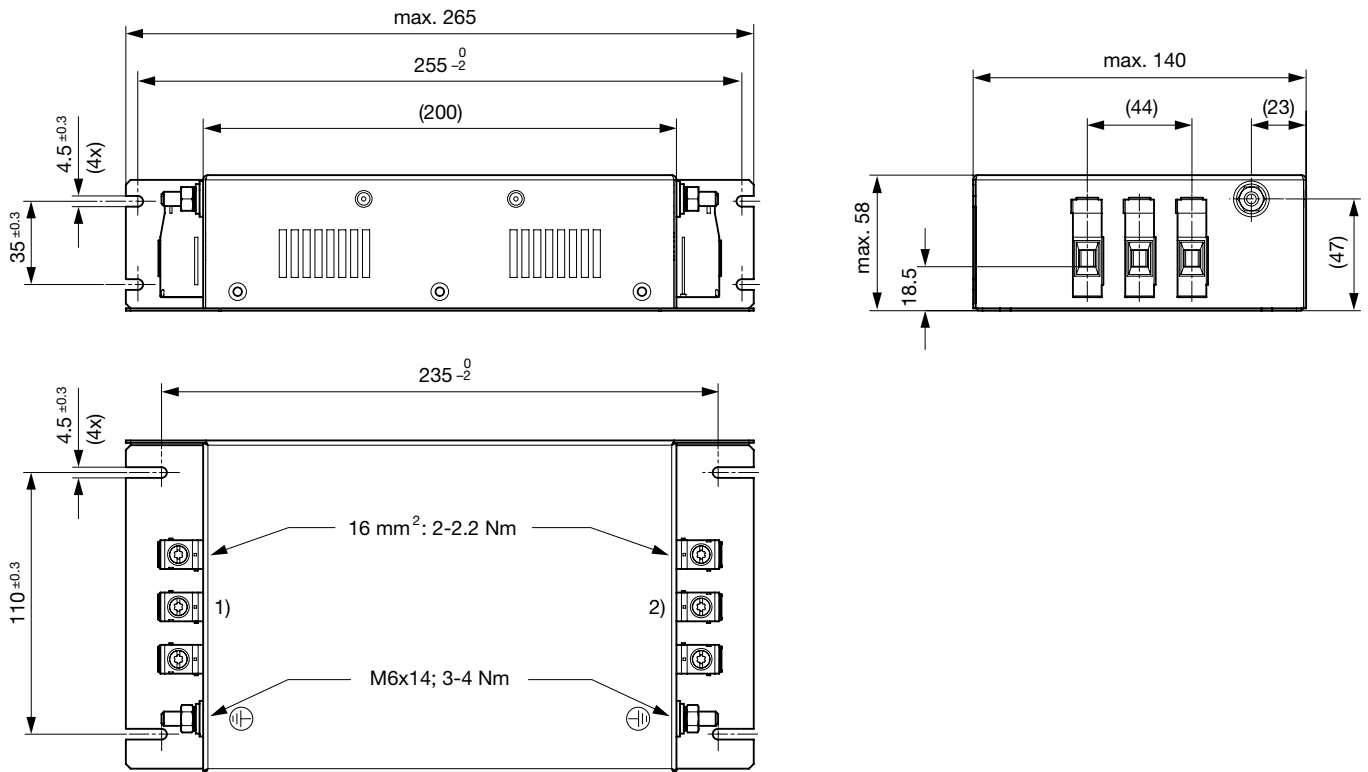

- 1) Line
- 2) Load

Case 1T

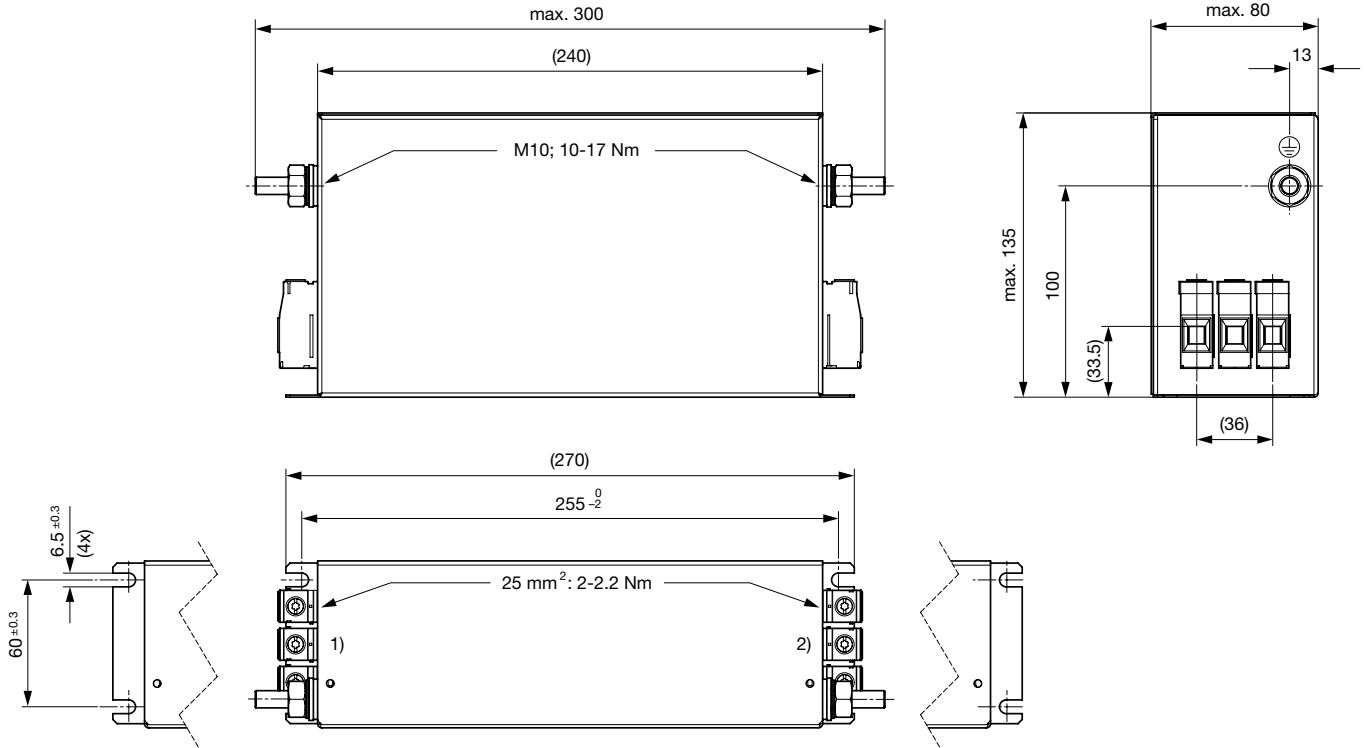

- 1) Line
- 2) Load

Case 1G

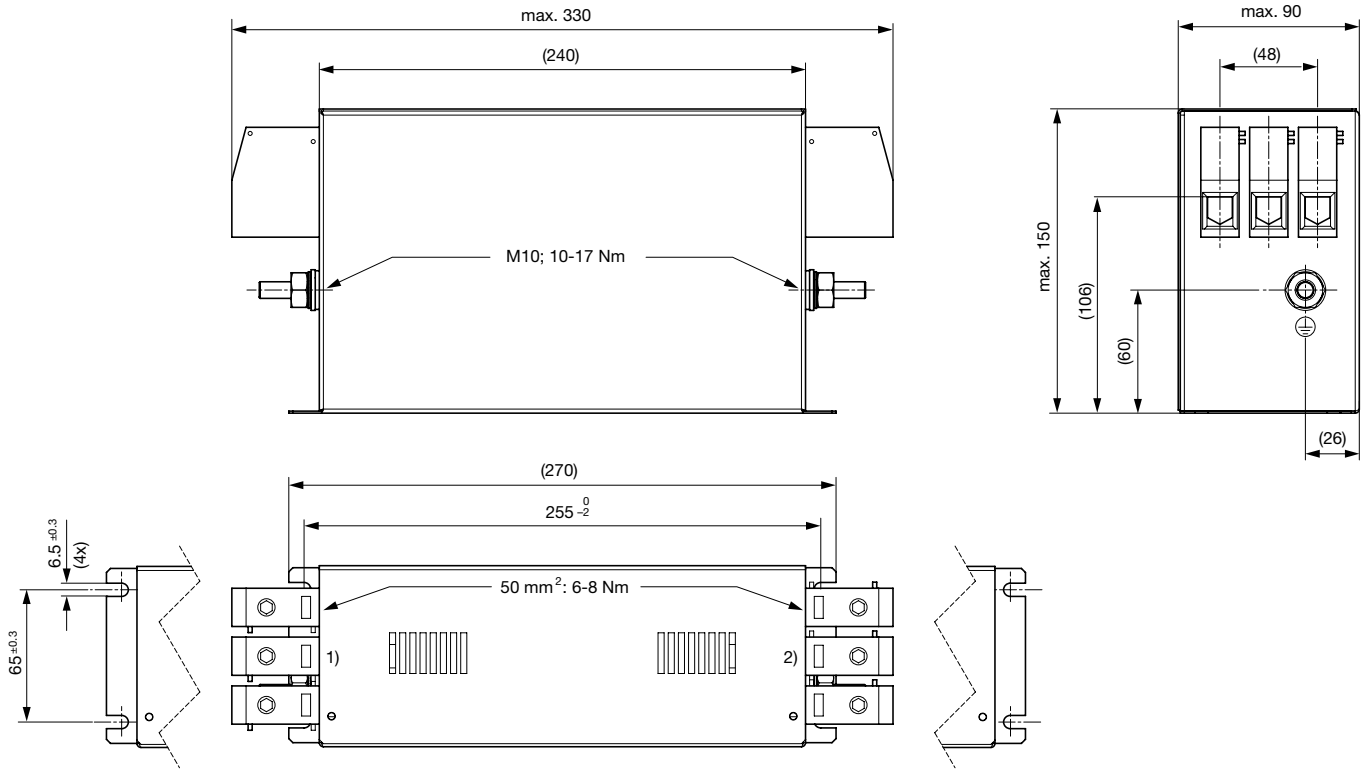

- 1) Line
- 2) Load

Technical data to the filter components

Rated Current [A]	L [mH]	C1 [μF]	C2 [μF]	C3 [μF]	R1 [MΩ]	R2 [MΩ]	Filter-Type
110	0.55	6.6	6.6	3.3	1	1	Indus-
150	0.48	6.6	6.6	3.3	1	1	Indus-
16	0.55	2.2	2.2	3.3	1	1	Indus-
25	0.45	2.2	2.2	3.3	1	1	Indus-
36	0.57	2.2	2.2	3.3	1	1	Indus-
50	0.65	4.7	3.3	3.3	1	1	Indus-
55	0.75	4.7	3.3	3.3	1	1	Indus-
64	0.55	4.7	3.3	3.3	1	1	Indus-
80	0.55	4.7	4.7	3.3	1	1	Indus-

Diagrams

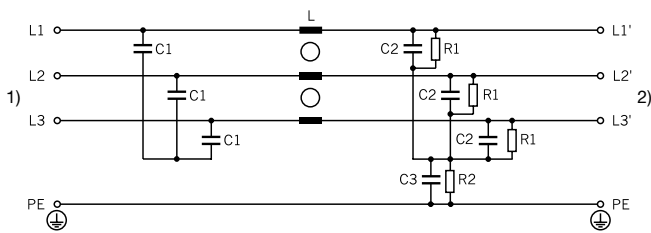

- 1) Line
- 2) Load

Attenuation Loss

- - - differential mode ____ common mode

Industrial version

16A (FMAC-091C-1610)

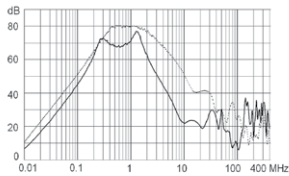

25A (FMAC-091C-2510)

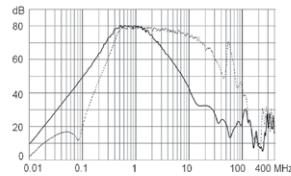

36A (FMAC-091D-3610)

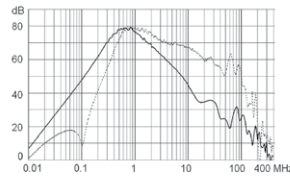

50A (FMAC-091D-5010)

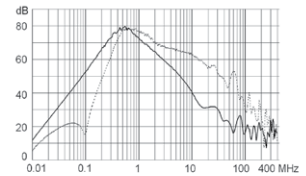

55A (FMAC-091D-5510)

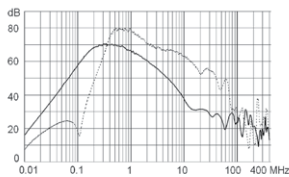

64A (FMAC-091E-6410)

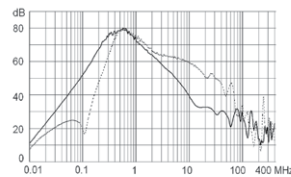

80A (FMAC-091T-8010)

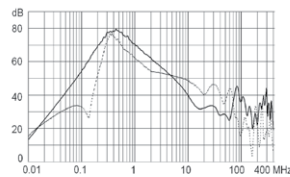

110A (FMAC-091G-H110)

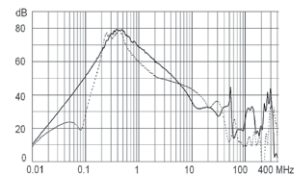

150A (FMAC-091G-H210)

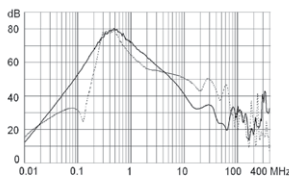

All Variants

Rated Current @ Ta 40°C (75°C) [A]	Characteristic	Rated Voltage [VAC]	Tripped Power Dissipation [W]	Leakage Current [mA] ¹⁾	Contact Resistance [mΩ]	Weight [kg]	Screw clamps [mm ²] ²⁾	Housing	Order Number
16	High attenuation	-	6	96	7.6	1 kg	4	1C	FMAC-091C-1610
25	High attenuation	-	8	96	4.1	1 kg	4	1C	FMAC-091C-2510
36	High attenuation	-	10	96	2.5	1.3 kg	6	1D-6	FMAC-091D-3610
50	High attenuation	-	13	103	1.7	1.7 kg	10	1D-10	FMAC-091D-5010
55	High attenuation	-	14	103	1.5	1.7 kg	10	1D-10	FMAC-091D-5510
64	High attenuation	-	17	103	1.4	2 kg	25	1E	FMAC-091E-6410
110	High attenuation	-	28	110	0.8	5.8 kg	50	1G	FMAC-091G-H110
150	High attenuation	-	40	110	0.6	7 kg	50	1G	FMAC-091G-H210
80	High attenuation	-	22	110	1.1	5.1 kg	25	1T	FMAC-091T-8010

Most Popular.

Availability for all products can be searched real-time: <http://www.schurter.com/en/Stock-Check/Stock-Check-SCHURTER>

1) Nominal leakage current acc. to IEC60950 - 5.2.5. under normal operating conditions. Note: worst case leakage current acc. to IEC60950 - Annex G4 (situation with two interrupted lines) can be much higher.

2) Maximum conductor cross section (wire gauge) to be used; a comparative table for AWG and mm² values can be found in the general product information www.schurter.com/emc_info

Packaging unit 1 Pcs