

TWR-KV31F120M Tower Module User's Guide

1 TWR-KV31F120M

The TWR-KV31F120M microcontroller module is designed to work in standalone mode or as part of the Freescale Tower system, a modular development platform that enables rapid prototyping and tool reuse through reconfigurable hardware. Take your design to the next level and begin constructing your Tower system today by visiting www.freescale.com/tower for additional Tower System microcontroller modules and compatible peripherals.

Contents

1. TWR-KV31F120M	1
2. Contents	2
3. TWR-KV31F120M features	3
4. Get to know the TWR-KV31F120M	3
5. Reference documents	4
6. Hardware description	4
6.1. Microcontroller	5
6.2. Clocking	6
6.3. System power	6
6.4. Debug interface	6
6.5. Accelerometer plus Magnetometer	7
6.6. Potentiometer, pushbuttons, and LEDs	8
6.7. General Purpose Tower Plug-in (TWRPI) socket	8
7. TWR-KV31F120M jumper options and headers	9
8. Useful links	11
9. Revision history	12

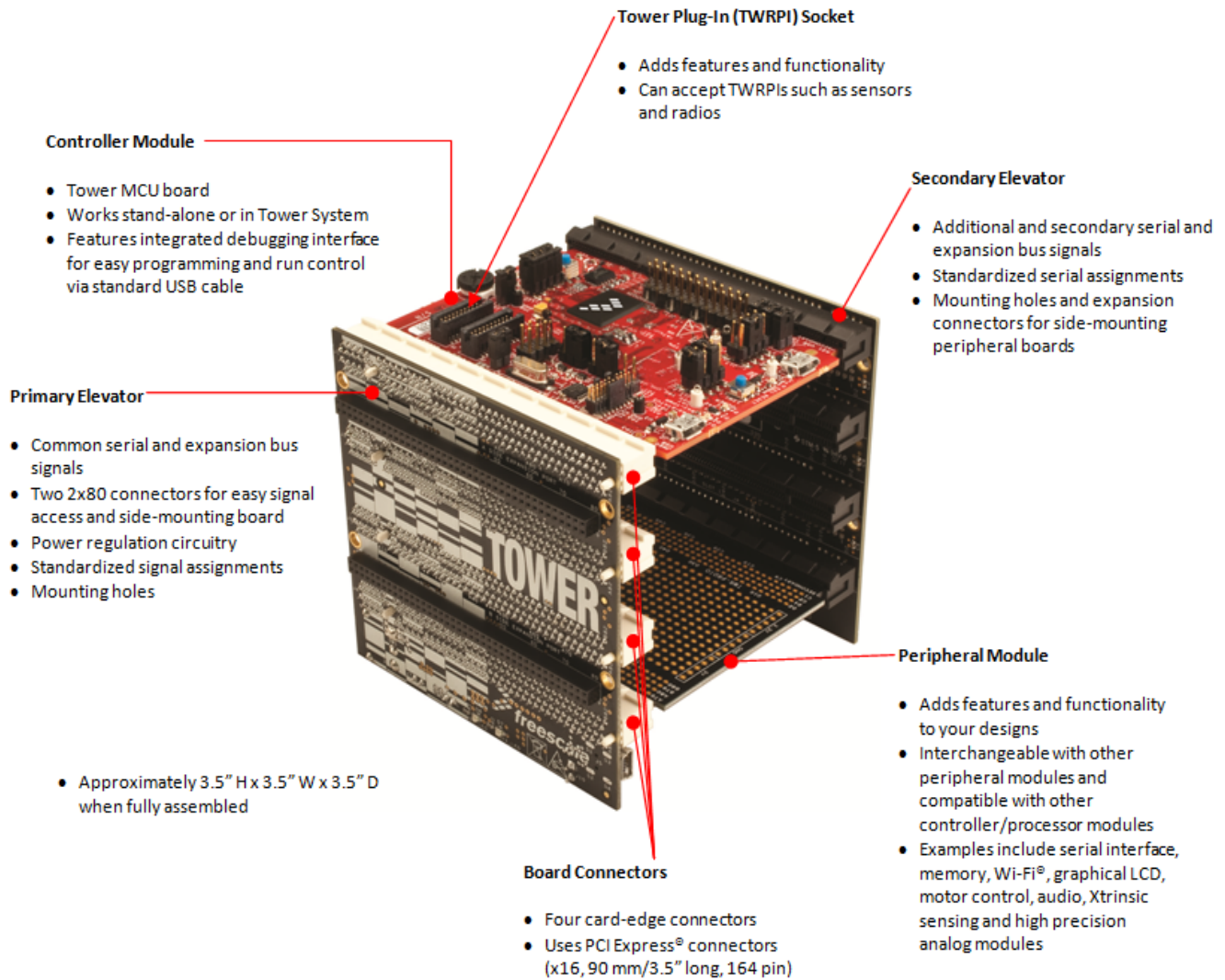

Figure 1. Freescale tower system overview

2 Contents

The TWR-KV31F120M contents include:

- TWR-KV31F120M board assembly
- A to micro-B USB cable for debug interface and power
- Quick start guide

3 TWR-KV31F120M features

- Tower-compatible microcontroller module.
- KV31F512VLL12 MCU (120 MHz, 512 KB Flash, 96 KB RAM, low power, 100 LQFP package).
- General-purpose Tower Plug-in (TWRPI) socket.
- On-board debug circuit: K20DX128VFM5 (OpenSDA) with virtual serial port.
- FXOS8700CQ: 6-Axis Digital Sensor Accelerometer + Magnetometer.
- Four (4) user-controllable LEDs plus RGB LED.
- Four (4) user pushbutton switches for GPIO interrupts.
- One (1) user pushbutton switch for MCU reset.
- Potentiometer.

4 Get to know the TWR-KV31F120M

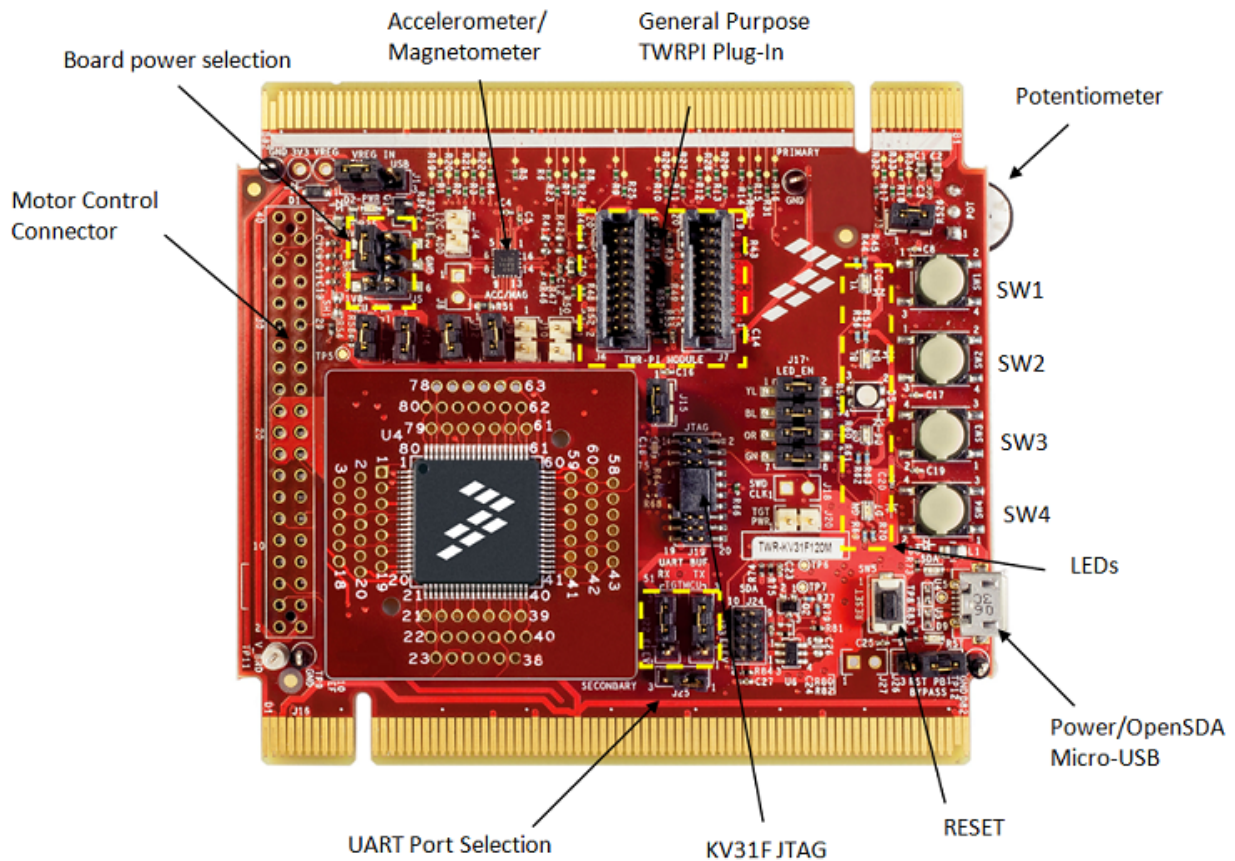

Figure 2. Front side of TWR-KV31F120M module (TWRPI devices not shown)

5 Reference documents

The documents listed below should be referenced for more information on the Kinetis K Series, Tower System, and MCU modules. These can be found in the documentation section of www.freescale.com/kinetis.

- TWR-KV31F120M-SCH (schematics)
- KV31P100M120SF7RM (reference manual)
- Tower configuration tool
- Tower mechanical drawing

6 Hardware description

The TWR-KV31F120M is a Tower MCU Module featuring the KV31F512VLL12—a Kinetis V Series microcontroller in a 100 LQFP package with high speed run mode. It is intended for use in the Freescale Tower System but can also operate alone. An on-board OpenSDA debug circuit provides a Serial Wire Debug (SWD) interface and a power supply input through a single micro-USB connector.

The block diagram of the TWR-KV31F120M board is presented in the following figure:

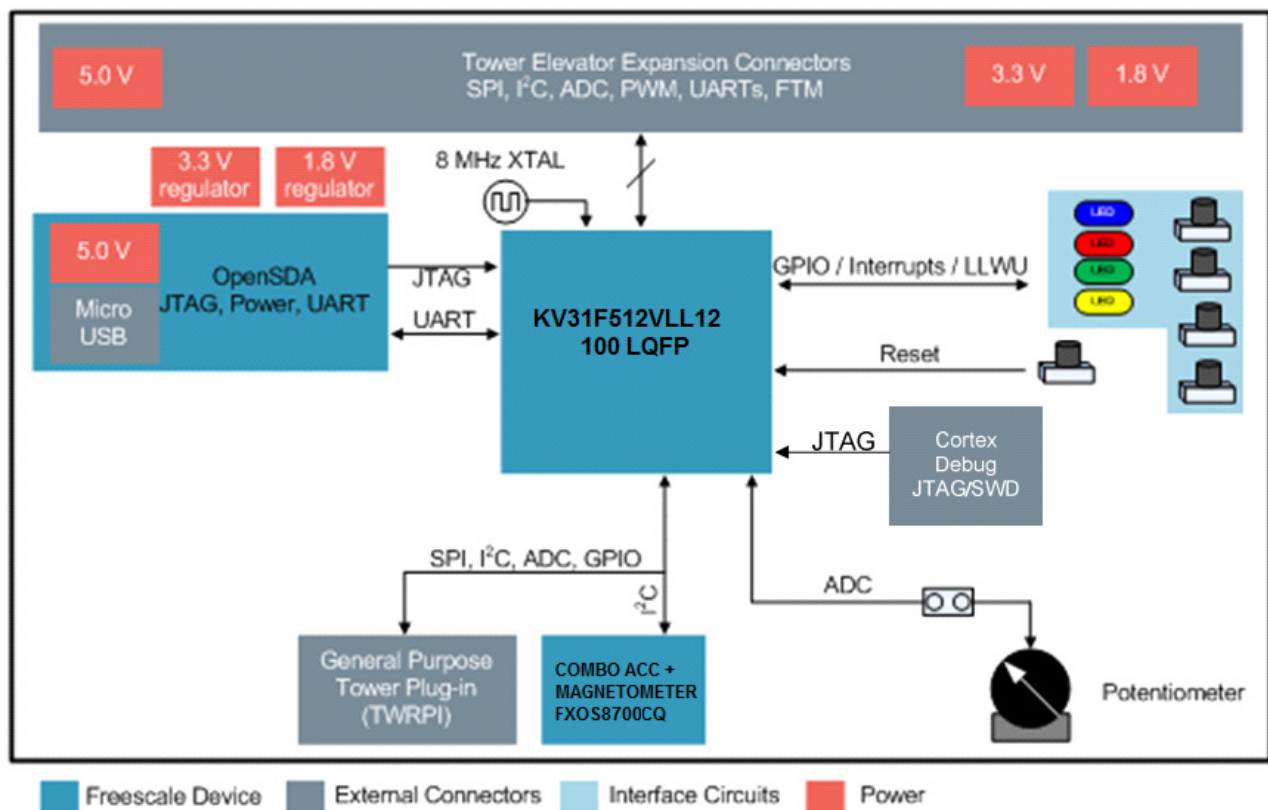

Figure 3. Block Diagram of TWR-KV31F120M

6.1 Microcontroller

The TWR-KV31F120M features the KV31F512VLL12 MCU. This 120 MHz microcontroller is part of the Kinetis KV3x family and is implemented in a 100 LQFP package. The following table notes some of the features of the KV31F512VLL12 MCU.

Table 1. Features of KV31F512VLL12

Feature	Description
Ultra low-power	<ul style="list-style-type: none"> • 11 low-power modes with power and clock gating for optimal peripheral activity and recovery times. • Full memory and analog operation down to 1.71 V for extended battery life • Low-leakage wake-up unit with up to three internal modules and 8 pins as wake-up sources in low-leakage stop (LLS) and very low-leakage stop (VLLS) modes • Low-power timer for continual system operation in reduced power states
Flash and SRAM	<ul style="list-style-type: none"> • 512-KB flash featuring fast access times, high reliability, and four levels of security protection • 96 KB of SRAM • No user or system intervention to complete programming and erase functions, and full operation down to 1.71 V
Mixed-signal capability	<ul style="list-style-type: none"> • High-speed 16-bit ADC with configurable resolution • Single or differential output modes for improved noise rejection • 500-ns conversion time achievable with programmable delay block triggering • Two high-speed comparators providing fast and accurate motor over-current protection by driving PWMs to a safe state • Optional analog voltage reference provides an accurate reference to analog blocks and replaces external voltage references to reduce system cost
Performance	<ul style="list-style-type: none"> • 120-MHz ARM Cortex-M4F core with DSP and FPU instruction set, single cycle MAC, and single instruction multiple data (SIMD) extensions • Up to 16 channel DMA for peripheral and memory servicing with reduced CPU loading and faster system throughput • Crossbar switch enables concurrent multi-master bus accesses, increasing bus bandwidth
Timing and control	<ul style="list-style-type: none"> • Up to four FlexTimers (FTM) with a total of 20 channels • Hardware dead-time insertion and quadrature decoding for motor control • Four-channel 32-bit periodic interrupt timer (PIT) provides time base for RTOS task scheduler, or trigger source for ADC conversion and programmable delay block
Connectivity and communications	<ul style="list-style-type: none"> • Four UARTs: <ul style="list-style-type: none"> – one UART that supports RS232 with flow control, RS485, and ISO7816 – two UARTs that support RS232 with flow control and RS485 – one low power UART (LPUART) • Two DSPI modules and two I²C modules
Reliability, safety, and security	<ul style="list-style-type: none"> • Cyclic redundancy check (CRC) engine validates memory contents and communication data, increasing system reliability • Independently-clocked COP guards against clock skew or code runaway for fail-safe applications such as the IEC 60730 safety standard for household appliances • External watchdog monitor drives output pin to safe state for external components in the event that a watchdog timeout occurs • Included in Freescale's product longevity program, with assured supply for a minimum of 10 years after launch

6.2 Clocking

Kinetis V Series MCUs start up from an internal digitally controlled oscillator (DCO). Software can enable the main external oscillator (EXTAL0/XTAL0) if desired. The external oscillator/resonator can range from 32.768 KHz up to 32 MHz. An 8-MHz crystal is the default external source for the MCG oscillator inputs (XTAL/EXTAL).

By connecting J25 (2-3) jumper enables other external clock sources for the KV31F512VLL12 include the CLKIN0 signal, which can be provided through the TWR-ELEV module or pin 20 of TWRPI connector J6.

6.3 System power

When installed into a Tower System, the TWR-KV31F120M can be powered from either an on-board source or from another source in the assembled Tower System.

In stand-alone operation, the main power source (5.0 V) for the TWR-KV31F120M module is derived from the OpenSDA USB micro-B connector (J21). Two low-dropout regulators provide 3.3 V and 1.8 V supplies from the 5.0 V input voltage. All of the user-selectable options can be configured using two headers, J1 and J5. Refer to sheet 4 of the TWR-KV31F120M schematics for more details.

6.4 Debug interface

There are two debug interface options provided: the on-board OpenSDA circuit and an external ARM Cortex JTAG connector. The ARM Cortex JTAG connector (J19) is a standard 2x10-pin connector that provides an external debugger cable access to the JTAG interface of the KV31F512VLL12. Alternatively, the on-board OpenSDA debug interface can be used to access the debug interface of the KV31F512VLL12.

6.4.1 OpenSDA

An on-board K20DX128VFM5-based OpenSDA circuit provides a SWD debug interface to the KV31F512VLL12. A standard USB A male to micro-B male cable (provided) can be used for debugging via the USB connector (J21).

The OpenSDA interface also provides a USB to serial bridge. Drivers for the OpenSDA interface are provided in the P&E Micro OpenSDA Tower Toolkit. These drivers and more utilities can be found online at <http://www.pemicro.com/opensda>.

6.4.2 Cortex debug connector

The Cortex Debug connector is a 20-pin (0.05") connector providing access to the SWD, JTAG, cJTAG, and EzPort signals available on the KV31 device. The pinout and KV31 pin connections to the debug connector (J19) are shown in [Table 2](#).

Table 2. Cortex debug connector

Pin	Function	TWR-KV31F120M connection
1	VTref	3.3 V MCU supply (MCU_PWR)
2	TMS / SWDIO	PTA3/UART0_RTS_b/FTM0_CH0/JTAG_TMS/SWD_DIO
3	GND	GND
4	TCK / SWCLK	PTA0/UART0_CTS_b/FTM0_CH5/JTAG_CLK/SWD_CLK/EZP_CLK
5	GND	GND
6	TDO/SWO	PTA2/UART0_TX/FTM0_CH7/JTAG_TDO/TRACE_SWO/EZP_DO
7	Key	–
8	TDI	PTA1/UART0_RX/FTM0_CH6/JTAG_TDI/EZP_DI
9	GNDDetect	PTA4/FTM0_CH1/MS/NMI_b/EZP_CS_b
10	nRESET	RESET_b
11	Target Power	5 V supply (via jumper J20)
12	–	NC
13	Target Power	5 V supply (via jumper J20)
14	–	NC
15	GND	GND
16	–	NC
17	GND	GND
18	–	NC
19	GND	GND
20	–	NC

6.5 Accelerometer plus Magnetometer

An FXOS8700CQ 6-Axis Digital Sensor Accelerometer + Magnetometer is connected to the KV31F512VLL12 MCU through an I²C interface (I2C0) and GPIO/IRQ signals (PTD0 and PTE24).

6.6 Potentiometer, pushbuttons, and LEDs

The TWR-KV31F120M also features:

- A potentiometer connected to an ADC input signal (ADC0_SE23).
- Four pushbutton switches
- SW1-PTC6/LLWU_P10, SW2-PTC11/LLWU_P11, SW3-PTA4/LLWU_P3, SW4-PTE25.
- Four user-controllable LEDs connected to GPIO signals (optionally isolated using jumpers):
 - Yellow LED (D3) to PTE1
 - Red LED (D4) to PTE0
 - Orange LED (D6) to PTB19
 - Green LED (D7) to PTD7
- RGB LED

6.7 General Purpose Tower Plug-in (TWRPI) socket

The TWR-KV31F120M features a socket (J6 and J7) that can accept a variety of different Tower Plug-in modules featuring sensors, RF transceivers, and other peripherals. The General Purpose TWRPI socket provides access to I2C, SPI, IRQs, GPIOs, timers, analog conversion signals, TWRPI ID signals, reset, and voltage supplies. The pinout for the TWRPI Socket is defined in [Table 3](#).

Table 3. General purpose TWRPI socket pinout

J6		J5	
Pin	Description	Pin	Description
1	5 V VCC	1	GND
2	3.3 V VCC	2	GND
3	GND	3	I2C: SCL
4	3.3 V VDDA	4	I2C: SDA
5	VSS (Analog GND)	5	GND
6	VSS (Analog GND)	6	GND
7	VSS (Analog GND)	7	GND
8	ADC: Analog 0	8	GND
9	ADC: Analog 1	9	SPI:MISO
10	VSS (Analog GND)	10	SPI:MOSI
11	VSS (Analog GND)	11	SPI:SS

J6		J5	
Pin	Description	Pin	Description
12	ADC: Analog 2	12	SPI:CLK
13	VSS (Analog GND)	13	GND
14	VSS (Analog GND)	14	GND
15	GND	15	GPIO:GPIO0/IRQ
16	GND	16	GPIO:GPIO1/IRQ
17	ADC: TWRPI ID 0	17	UART:UART_RX or GPIO: GPIO2
18	ADC: TWRPI ID 1	18	UART:UART_TX or GPIO: GPIO3
19	GND	19	UART:UART_CTS or GPIO:GPIO4/Timer
20	Resist	20	UART:UART_CTS or GPIO:GPIO5/Timer

7 TWR-KV31F120M jumper options and headers

The following is a list of all of the jumper options on the TWR-KV31F120M. The default installed jumper settings are indicated by white text on a black background

Table 4. TWR-KV31F120M jumper options

Option	Jumper	Setting	Description
Clock Input Source Selection	J25	1-2	Connect main EXTAL to on-board 8 MHz crystal
		2-3	Connect EXTAL to CLKIN0 signal on Primary Elevator (B24)
Debug Target Power	J20	ON	Connect P5V_SDA to target power
		OFF	Disconnect P5V_SDA from target power
Tower Voltage Regulator Input Selector	J1	1-2	[Default] Connect P5V_TRG_SDA (5V from OpenSDA) or P5_Elev to VREG_IN
		2-3	[EXT]Connect USB0_VBUS from Primary Elevator (A57) to VREG_IN
Board Power Selector	J5	1-3	Connect on-board 3.3V regulator output (P3V3_REG) to main board power line (V_BRD)
		3-5	Connect on-board 1.8V regulator output (P1V8) to main board power line (V_BRD)
MCU VDD current measurement	J13	ON	Connect V_BRD to MCU_PWR
		OFF	Allow current measurement on MCU VDD

Option	Jumper	Setting	Description
VDDA and VREFH Power	J14	ON	Connect V_BRD to VDDA and VREFH
		OFF	Disconnect V_BRD from VDDA and VREF
LED Connections	J17	1-2	Connect PTE1 to Yellow LED D3
		3-4	Connect PTE0 to Red LED D4
		5-6	Connect PTB19 to Orange LED D6
		7-8	Connect PTD7 Green LED D7
TWRPI Current Measurement	J15	ON	Connect V_BRD to TWRPI 3-V power (GPT_VBRD)
		OFF	Disconnect V_BRD from TWRPI 3-V power (GPT_VBRD)
Accelerometer/Magnetometer* I2C SCL Connection	J9	ON	Connect PTD2 to I2C_SCL_SNSR
		OFF	Disconnect PTD2 from I2C_SCL_SNSR
Accelerometer/Magnetometer I2C SDA Connection	J12	ON	Connect PTD3 to I2C_SDA_SNSR
		OFF	Disconnect PTD3 from I2C_SDA_SNSR
Accelerometer/Magnetometer I2C Slave Address	J4	ON	Pull accelerometer/magnetometer SA0 low
		OFF	Pull accelerometer/magnetometer SA0 high
Magnetometer I2C Slave Address	J8	ON	Pull magnetometer SA1 high
		OFF	Pull magnetometer SA1 low (also used for accelerometer GND)
Accelerometer/Magnetometer I2C Interrupt 1	J11	ON	Connect PTD0 to INT1
		OFF	Disconnect PTD0 from INT1
Accelerometer/Magnetometer I2C Interrupt 2	J10	ON	Connect PTE24 to INT2
		OFF	Disconnect PTE24 from INT2
Potentiometer Enable	J3	ON	Connect DAC0_OUT/ADC0_SE23 to POT_5K
		OFF	Disconnect DAC0_OUT/ADC0_SE23 from POT_5K
Reset Pushbutton	J26	1-2	Connect SW5 to SDA_RST_TGTMCU_J_B
		2-3	Connect SW5 to RST_TGTMCU_B (Needed when OpenSDA is not powered)
UART RX Selection	J22	1-2	Connect UART0_RX_TGTMCU to UART1_RX_ELEV_BUF (Tower Elevator)
		2-3	Connect UART0_RX_TGTMCU to UART1_RX_TGTMCU_BUF (OpenSDA)
UART TX Selection	J23	1-2	Connect UART0_TX_TGTMCU to UART1_TX_ELEV_BUF (Tower Elevator)
		2-3	Connect UART0_TX_TGTMCU to UART1_TX_TGTMCU_BUF (OpenSDA)

*FXOS8700CQ Accelerometer/Magnetometer is standard. MMA8451Q Accelerometer is optional

The following figure shows jumper default position on TWR-KV31F120M.

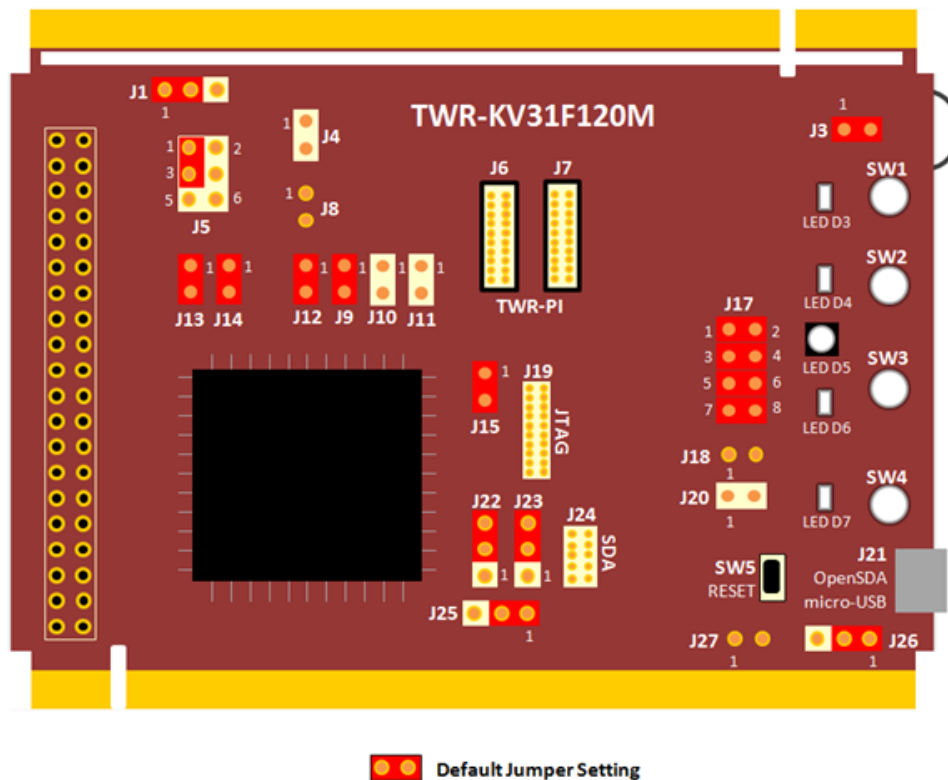

Figure 4. Jumper default position

8 Useful links

- www.freescale.com
 - [freescale.com/Kinetis](http://www.freescale.com/Kinetis)
- www.iar.com/freescale
- www.pemicro.com
 - <http://www.pemicro.com/opensda>
- www.segger.com
 - <http://www.segger.com/jlink-flash-download.html>

9 Revision history

Table 5. Revision history

Revision number	Date	Substantial changes
0	03/2014	Initial release

How to Reach Us:

Home Page:
freescale.com

Web Support:
freescale.com/support

Information in this document is provided solely to enable system and software implementers to use Freescale products. There are no express or implied copyright licenses granted hereunder to design or fabricate any integrated circuits based on the information in this document.

Freescale reserves the right to make changes without further notice to any products herein. Freescale makes no warranty, representation, or guarantee regarding the suitability of its products for any particular purpose, nor does Freescale assume any liability arising out of the application or use of any product or circuit, and specifically disclaims any and all liability, including without limitation consequential or incidental damages. "Typical" parameters that may be provided in Freescale data sheets and/or specifications can and do vary in different applications, and actual performance may vary over time. All operating parameters, including "typicals," must be validated for each customer application by customer's technical experts. Freescale does not convey any license under its patent rights nor the rights of others. Freescale sells products pursuant to standard terms and conditions of sale, which can be found at the following address: freescale.com/SalesTermsandConditions.

Freescale, the Freescale logo, and Kinetis are trademarks of Freescale Semiconductor, Inc., Reg. U.S. Pat. & Tm. Off. Tower is a trademark of Freescale Semiconductor, Inc. All other product or service names are the property of their respective owners. ARM and Cortex are registered trademarks of ARM Limited (or its subsidiaries) in the EU and/or elsewhere. All rights reserved.

© 2014 Freescale Semiconductor, Inc.



Document Number: TWRKV31F120MUG
Rev. 0
03/2014

