

Dimensions and Specifications

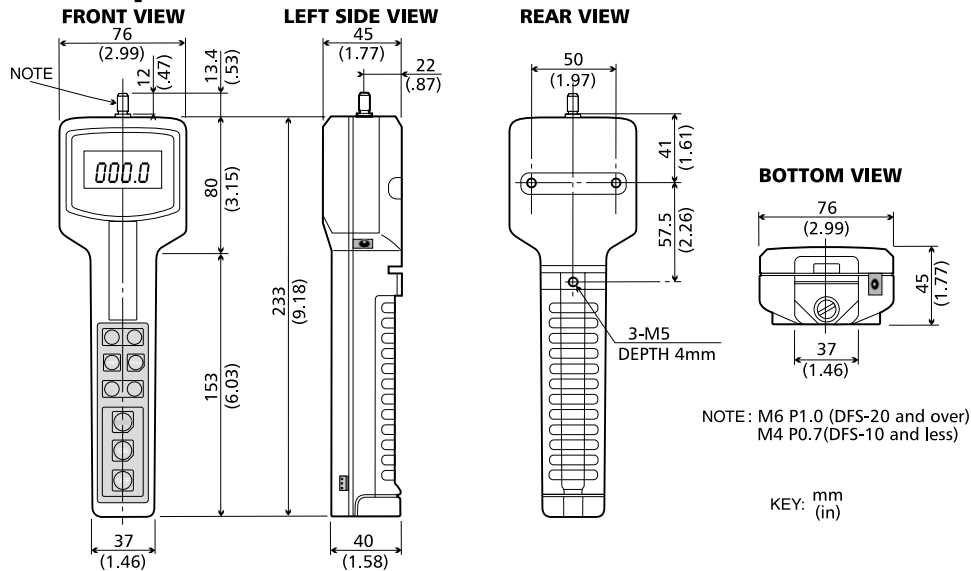

MODELS	DFS-0.5 DFS-0.5R	DFS-1 DFS-1R	DFS-2 DFS-2R	DFS-5 DFS-5R	DFS-10 DFS-10R	DFS-20 DFS-20R	DFS-50 DFS-50R	DFS-100 DFS-100R
CAPACITY	8 oz 200 g 2 N	16 oz 500 g 5 N	2 lb 1000 g 10 N	5 lb 2 Kg 20 N	10 lb 5 Kg 50 N	20 lb 10 Kg 100 N	50 lb 20 Kg 200 N	100 lb 50 Kg 500 N
RESOLUTION	0.01 oz		0.001 lb		0.01 lb		0.1 lb	
	0.1 g		1 g		0.001 Kg		0.01 Kg	
	0.001 N		0.01 N				0.1 N	
ACCURACY	±0.2% FS + 1/2 digit at 23°C							
DISPLAY	4-Digit LCD, 11.5 mm High with various indicators including Low Battery Indication and minus sign for Tension.							
MEASURING MODE	Average, Peak Compression, Peak Tension (selectable)							
DISPLAY UPDATE	125 ms, 250 ms, 1 sec, 2 sec (selectable)							
SAMPLING RATE	Average Mode: 125 ms, 250 ms, 1 sec, 2 sec Peak Mode: 1 ms, 125 ms, 250 ms, 1 sec, 2 sec							
TEMPERATURE COEFFICIENT	Zero: ±0.02% FS/°C (max.), Span: ±0.015% of reading/°C (max.)							
OUTPUTS	1. RS232C 2. Digimatic: (works with Mitutoyo's printer model DP-1HS) 3. Analog: (±1VDC with load impedance of 2K or higher and tare function capability.)							
OVERLOAD CAPACITY	200% of FS							
COMPARATOR OUTPUT (Set Points)	Three open collector NPN transistors for HI, GO, and LO (28VDC, 7 ma max.)							
OVERLOAD OUTPUT	Two open collector NPN transistors one for Tension and one for Compression (28VDC, 5 ma max.)							
TARE & HOLD CONTROL	Relay contact (selectable)							
MEMORY	Holds 100 samples plus statistics (MAX, MIN, AVG, and Standard Deviation)							
POWER	4 - AA Alkaline batteries. Last approx. 20hrs. in continuous operation or AC Adapter for continuous use (6VDC, 200 ma)							
AUTO POWER SHUT-OFF	Selectable (3 minutes if there is no activity)							
OPERATING TEMP RANGE	32 - 113°F (0 - 45°C)							
DIMENSIONS/WEIGHT	3"W x 1.77"H x 9.72"L (76 x 45 x 247)mm /1.2 lbs. (550 g)							
ACCESSORIES (Included)	Batteries, carrying case, overload output cable, AC adapter, 6 adapters (flat head, hook, chisel, notched head, cone & extension rod)							
ACCESSORIES (Available)	Test stands, RS232C cable, Digimatic, analog and comparator output cables.							

Warranty

LIMITED EXPRESS WARRANTY: Shimpo Instruments warrants, to the original purchaser of new products only, that this product shall be free from defects in workmanship and materials under normal use and proper maintenance for one year from the date of original purchase. This warranty shall not be effective if the product has been subject to overload, misuse, negligence, or accident, or if the product has been repaired or altered outside of Shimpo Instruments's authorized control in any respect which in Shimpo Instruments's judgment, adversely affects its condition or operation.

DISCLAIMER OF ALL OTHER WARRANTIES: The foregoing warranty constitutes the SOLE AND EXCLUSIVE WARRANTY, and Shimpo Instruments hereby disclaims all other warranties, expressed, statutory or implied, applicable to the product, including, but not limited to all implied warranties of merchantability and fitness.

LIMITATION OF REMEDY: Under this warranty, Shimpo Instruments' SOLE OBLIGATION SHALL BE TO REPAIR OR REPLACE the defective product or part, at Shimpo Instruments' option. Shimpo Instruments reserves the right to satisfy warranty obligation in full by reimbursing Buyer for all payments made to Shimpo Instruments, whereupon, title shall pass to Shimpo Instruments upon acceptance of return goods. To obtain warranty service, Purchaser must obtain Shimpo Instruments's authorization before returning the product, properly repackaged, freight pre-paid to Shimpo Instruments.

INDEMNIFICATION & LIMITATION OF DAMAGES: Buyer agrees to indemnify and hold Shimpo Instruments harmless from and against all claims and damages imposed upon or incurred arising, directly or indirectly, from Buyer's failure to perform or satisfy any of the terms described herein. In no event shall Shimpo Instruments be liable for injuries of any nature involving the product, including incidental or consequential damages to person or property, any economic loss or loss of use.

MERGER CLAUSE: Any statements made by the Seller's representative do not constitute warranties except to the extent that they also appear in writing. This writing constitutes the entire and final expression of the parties' agreement.

Copyright® Nidec-Shimpo America Corporation 2001. All rights reserved. Product specifications are subject to change without notice.

NIDEC-SHIMPO AMERICA CORPORATION • 1701 Glenlake Avenue Itasca, IL 60143 USA • Phone: (800) 237-7079 • Fax: (630) 924-0342
 www.shimpoinst.com • info@shimpoinst.com