

PH100F24

SPECIFICATION

C101 - 01 - 01A

MODEL		PH100F	PH100F	PH100F	PH100F	PH100F	PH100F	PH100F	PH100F
ITEMS		24-2	24-3	24-5	24-12	24-15	24-24	24-28	
1	Nominal Output Voltage	V	2	3	5	12	15	24	28
2	Maximum Output Current	A	20	20	20	8.4	6.7	4.2	3.6
3	Nominal Output Power	W	40	60	100	100.8	100.5	100.8	100.8
4	Efficiency (Typ.) (*1)	%	66	70	80	81	82	83	83
5	Input Voltage Range	-	18 ~ 36VDC						
6	Input Current (Typ.) (*1)	A	2.53	3.57	5.21	5.19	5.11	5.06	5.06
7	Output Voltage Accuracy (*1)	-	±1%						
8	Output Voltage Range (*10)	-	±20%		+20%, -60%				
9	Maximum Ripple & Noise (*9)	mV	100	100	100	150	150	240	280
10	Maximum Line Regulation (*2)	mV	20	20	20	48	60	96	112
11	Maximum Load Regulation (*3)	mV	40	40	40	96	120	192	224
12	Over Current Protection (*4)	A	105% ~ 140%						
13	Over Voltage Protection (*5)	V	165% ~ 240%		125% ~ 145%				
14	Remote Sensing (*8)	-	Possible						
15	Remote ON/OFF Control (*8)	-	Possible (SHORT:ON OPEN:OFF)						
16	Parallel Operation (*8)	-	Possible						
17	Series Operation (*8)	-	Possible						
18	I.O.G. Signal (*8)	-	Possible (Open Collector Output)						
19	Operating Temperature (*6)	-	- 20°C ~ + 85°C (Base plate) Ambient Temperature MIN = - 20°C.						
20	Operating Humidity	-	30 - 95%RH (No Dewdrop)						
21	Storage Temperature	-	- 40°C ~ + 85°C						
22	Storage Humidity	-	10 - 95%RH (No Dewdrop)						
23	Cooling (*7)	-	Conduction Cooled						
24	Temperature Coefficient (%)	-	0.02% / °C						
25	Withstand Voltage	-	Input-Baseplate : 2kVAC, Input-Output : 2kVAC(20mA) for 1min Output-Baseplate : 500VDC(100mA) for 1min						
26	Isolation Resistance	-	More than 100Mohm at 25°C and 70%RH Output-Baseplate...500VDC						
27	Vibration	-	At No Operating, 10-55Hz (Sweep for 1min) Amplitude 0.825mm Constant (Maximum 49.0m/s ²) X,Y,Z 1h each						
28	Shock	-	196.1m/s ² (In package)						
29	Weight (Typ.)	-	180g						
30	Size (W x H x D)	mm	83 x 12.7 x 86 (Refer to Outline Drawing)						

=NOTES=

- *1. At 24VDC and Maximum Output Current.
- *2. 18 ~ 36VDC, Constant Load.
- *3. No load ~ Full load, Constant input voltage.
- *4. Constant current limiting with automatic recovery.
- *5. Inverter shutdown method, Manual Reset.
- *6. Ratings - Refer to Derating Curve on the Right.
- Load(%) is Percent of Maximum Output Current.
- *7. Heatsink has to be Chosen According to Instruction Manual.
- *8. Refer to Instruction Manual.
- *9. External Components are Needed for Operation.
(Refer to Basical Connection and Instruction Manual)
- *10. At 24VDC Input.(Refer to Instruction Manual.)

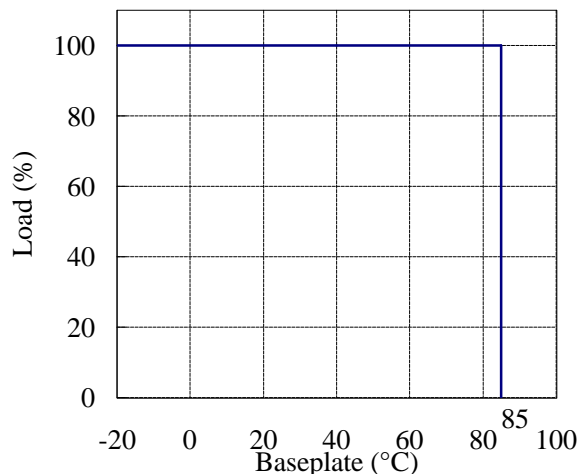
DERATING CURVE

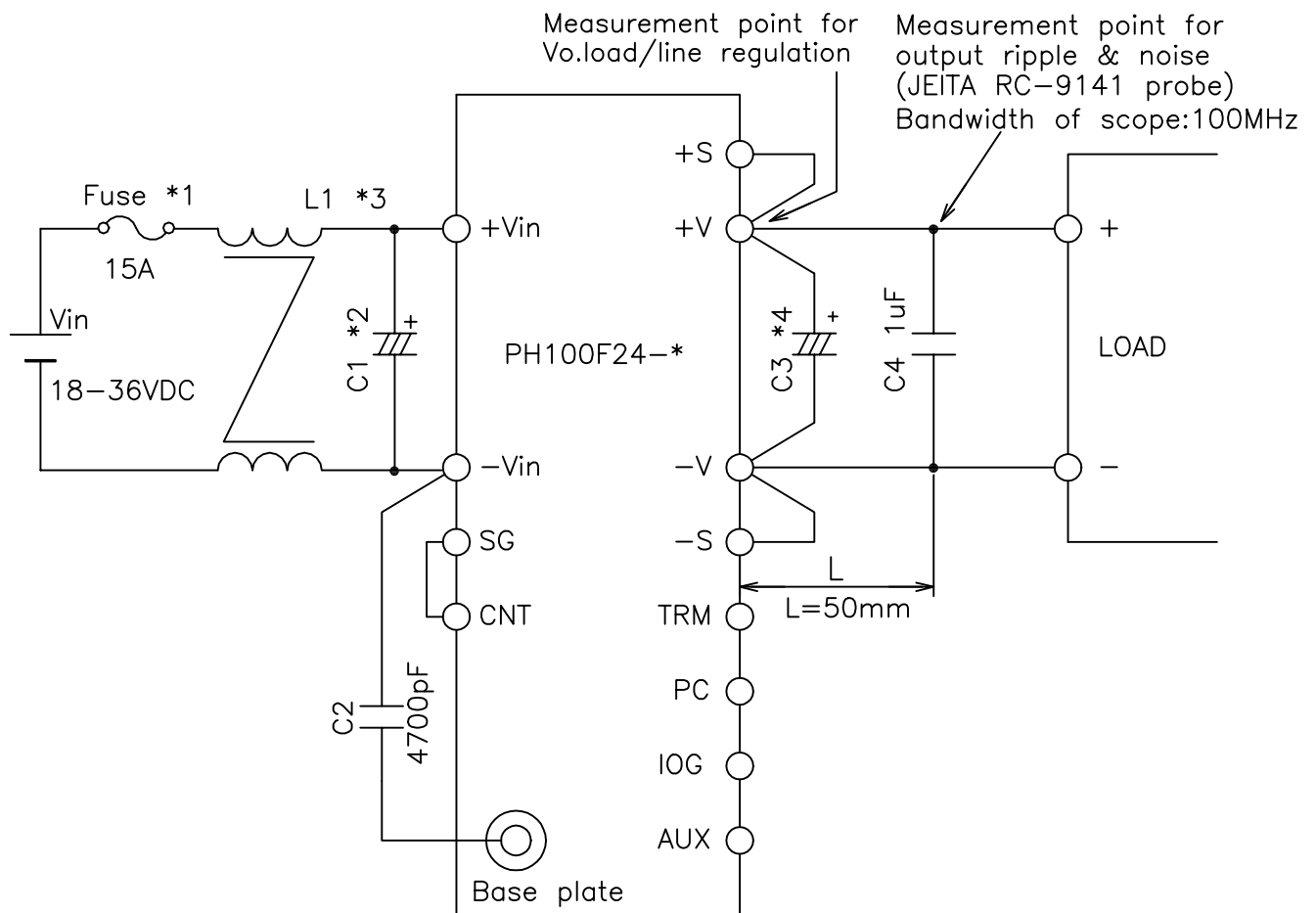

==NOTE==

- *1. Use an external fuse of fast blow type, for each unit.
- *2. When the input line impedance is high, insert input capacitor, C1, more than 470uF. (Refer to instruction manual)
- *3 Put an input common mode choke coil, L1, more than 1mH.
- *4. Put an output capacitor. (2,3V: more than 2,200uF, 5V: more than 1,000uF, 12V,15V: more than 470uF, 24V,28V: more than 220uF)
- *5. Refer to instruction manual for further details.

(unit : mm)

MODEL NAME	PH100F24
DENSEI-LAMBDA	

C101-01-02B