



Micropower Omnipolar  
Digital Hall-effect Sensor ICs  
**SL353 Series**

# Micropower Omnipolar Digital Hall-effect Sensor ICs

SL353 Series Micropower Omnipolar Digital Hall-effect Sensor ICs are small, and versatile, digital Hall-effect devices operated by the magnetic field from a permanent magnet or an electromagnet. These sensitive devices are designed to meet a wide range of potential applications with low power requirements including battery-operated equipment.

The SL353 Series devices respond to either a North or South Pole, meaning that they do not require the magnet polarity to be identified, providing an easier installation and potentially reducing system cost.

These low-power sensing devices use BiCMOS (Bipolar Complementary Metal Oxide Semiconductor) technology and a timing circuit that turns the power on for only a short time – it is off for the rest of the period (duty cycle) – significantly reducing the average current consumption.

Micropower omnipolar digital Hall-effect sensor ICs can operate from a supply voltage as low as 2.2 V, promoting energy efficiency.

The push-pull output does not require a pull-up resistor and can operate with very low current levels, potentially helping to reduce cost and minimizing the total current consumption.

The SL353 Series is available in two duty cycle configurations to accommodate a variety of application needs:

- SL353HT: High duty cycle (13 % typ.) for applications requiring high switching speed and a lower current (0.33 mA typ.) than standard Hall-effect sensor ICs.
- SL353LT: Very low duty cycle (0.013 % typ.) resulting in extended battery life in applications requiring extremely low current drain (1.8  $\mu$ A typ.) and not requiring a high switching speed.

The SL353 Series has a typical operating point of  $\pm 60$  Gauss at 25 °C [77 °F].

These sensors are available in a subminiature SOT-23 surface mount package on tape and reel (3000 units per reel), for use in automated pick-and-place component installation.

## What makes our sensors better?

- Energy efficient  
Supply voltage as low as 2.2 Vdc, combined with very low average current (1.8  $\mu$ A typ. for SL353LT the lowest in its class), reduces power consumption, provides extended battery life, and promotes energy efficiency.
- Push-pull output does not require external pull-up resistor  
Simplifies interface with common electrical circuits and likely reducing PCB (Printed Circuit Board) space and costs to the customer.
- Non-chopper stabilized design  
Does not utilize chopper stabilization, eliminating the noise generated by products using this technique. Customers do not need filters to eliminate the chopper noise, helping to reduce PCB (Printed Circuit Board) space, part counts, and costs for the application.

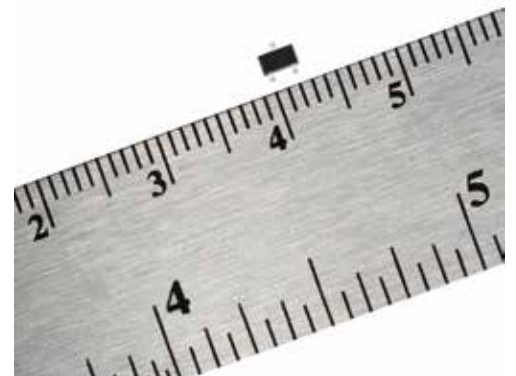

ENERGY EFFICIENT • NON-CHOPPER STABILIZATION

## Features and Benefits

### **VERSATILE**

Omnipolar capability with high-duty and low-duty cycle options allows for use in a variety of potential applications with low power requirements and/or battery operations.

### **STABLE**

Thermally balanced integrated circuit provides for stable operation over a wide temperature range, from -40 °C to 85 °C [-40 °F to 185 °F].

*Offers value-priced solution*

### **PRICE COMPETITIVE**

By using BiCMOS technology, Honeywell has been able to design a full-featured integrated circuit with reduced size, saving on manufacturing costs, and resulting in more economical pricing to customers.

### **HELPS REDUCE TOTAL SYSTEM COST**

SL353 Series Hall-effect sensor ICs can be operated by a North Pole or a South Pole. They do not require the magnet polarity to be identified, thus making the installation easier and potentially reducing the system cost.

### **REDUCES MANUFACTURING COSTS**

SL353 Series is supplied on tape and reel, allowing for automated, pick-and-place assembly which can help the customer reduce manufacturing costs.

### **DOES NOT REQUIRE EXTERNAL COMPONENTS**

The push-pull output does not require a pull-up resistor, potentially helping to reduce component and PCB (Printed Circuit Board) cost.

### **ROHS-COMPLIANT MATERIALS MEET DIRECTIVE 2002/95/EC**

## Potential Applications



### **BATTERY-OPERATED, MOBILE EQUIPMENT**

- Door or lid closure detection in computer notebooks, scanners, hand-held industrial computers and instrumentation
- Mobile printer head position sensing
- Small, hand-held medical and dental equipment
- Trigger switch for battery-operated hand tools (e.g. drills, drivers)
- Reed switch replacement in battery-operated security systems
- Magnetic encoder for building access (array)
- Power switch or open-close detection in small battery-operated appliances (e.g. vacuum cleaners, fans)
- Gas or water consumption measurement in remote, battery-operated utility meters

# SL353 Series

**Table 1. Electrical and Environmental Characteristics for SL353 Series<sup>1</sup>**

(At 2.2 V ≤ V<sub>s</sub> ≤ 5.5 V, -40 °C ≤ T<sub>a</sub> ≤ 85 °C [185 °F] and V<sub>s</sub> = 2.8 V, T<sub>a</sub> = 25 °C unless otherwise specified.)

Characteristics	Condition	Min.	Typ.	Max.	Unit
Supply voltage (V <sub>s</sub> )	T <sub>a</sub> = -40 °C to 85 °C [-40 °F to 185 °F]	2.2	2.8	5.5	V
Active mode current	V <sub>s</sub> = 2.8 V, T <sub>a</sub> = 25 °C [77 °F]	-	2.5	4	mA
	V <sub>s</sub> = 2.2 V to 5.5 V, T <sub>a</sub> = -40 °C to 85 °C [-40 °F to 185 °F]	-	2.5	9	mA
Sleep mode current	V <sub>s</sub> = 2.8 V, T <sub>a</sub> = 25 °C [77 °F]	-	1.5	2.5	μA
	V <sub>s</sub> = 2.2 V to 5.5 V, T <sub>a</sub> = -40 °C to 85 °C [-40 °F to 185 °F]	-	1.5	8	μA
Average current					
SL353HT	V <sub>s</sub> = 2.8 V, T <sub>a</sub> = 25 °C [77 °F]	-	0.33	0.64	mA
SL353HT	V <sub>s</sub> = 2.2 V to 5.5 V, T <sub>a</sub> = -40 °C to 85 °C [-40 °F to 185 °F]	-	0.33	2.3	mA
SL353LT	V <sub>s</sub> = 2.8 V, T <sub>a</sub> = 25 °C [77 °F]	-	1.8	3	μA
SL353LT	V <sub>s</sub> = 2.2 V to 5.5 V, T <sub>a</sub> = -40 °C to 85 °C [-40 °F to 185 °F]	-	1.8	9	μA
Active mode time	V <sub>s</sub> = 2.8 V, T <sub>a</sub> = 25 °C [77 °F]	3	6	9	μs
	V <sub>s</sub> = 2.2 V to 5.5 V, T <sub>a</sub> = -40 °C to 85 °C [-40 °F to 185 °F]	3	6	30	μs
Period					
SL353HT	V <sub>s</sub> = 2.8 V, T <sub>a</sub> = 25 °C [77 °F]	30	45	80	μs
SL353HT	V <sub>s</sub> = 2.2 V to 5.5 V, T <sub>a</sub> = -40 °C to 85 °C [-40 °F to 185 °F]	20	45	150	μs
SL353LT	V <sub>s</sub> = 2.8 V, T <sub>a</sub> = 25 °C [77 °F]	30	45	80	ms
SL353LT	V <sub>s</sub> = 2.2 V to 5.5 V, T <sub>a</sub> = -40 °C to 85 °C [-40 °F to 185 °F]	20	45	150	ms
Duty cycle					
SL353HT	V <sub>s</sub> = 2.8 V, T <sub>a</sub> = 25 °C [77 °F]	10	13	16	%
SL353HT	V <sub>s</sub> = 2.2 V to 5.5 V, T <sub>a</sub> = -40 °C to 85 °C [-40 °F to 185 °F]	5	13	25	%
SL353LT	V <sub>s</sub> = 2.8 V, T <sub>a</sub> = 25 °C [77 °F]	0.01	0.013	0.016	%
SL353LT	V <sub>s</sub> = 2.2 V to 5.5 V, T <sub>a</sub> = -40 °C to 85 °C [-40 °F to 185 °F]	0.005	0.013	0.025	%
V out					
High	V <sub>s</sub> = 2.8 V, T <sub>a</sub> = 25 °C [77 °F], load current = 100 μA	V <sub>s</sub> - 0.15	V <sub>s</sub> - 0.11	-	V
High	V <sub>s</sub> = 2.2 V to 5.5 V, T <sub>a</sub> = -40 °C to 85 °C [-40 °F to 185 °F], load current = 100 μA	V <sub>s</sub> - 0.25	V <sub>s</sub> - 0.11	-	V
Low	V <sub>s</sub> = 2.8 V, T <sub>a</sub> = 25 °C [77 °F], load current = 100 μA	-	0.11	0.15	V
Low	V <sub>s</sub> = 2.2 V to 5.5 V, T <sub>a</sub> = -40 °C to 85 °C [-40 °F to 185 °F], load current = 100 μA	-	0.11	0.25	V
Operating temperature	V <sub>s</sub> = 2.2 V to 5.5 V, T <sub>a</sub> = -40 °C to 85 °C [-40 °F to 185 °F]	-40 [-40]	-	85 [185]	°C [°F]
Storage temperature	-	-40 [-40]	-	150 [302]	°C [°F]

Note 1: These Hall-effect sensors ICs may have an initial output in either the on or off state if powered up with an applied magnetic field in the differential zone (applied magnetic field > Brp and < Bop). Honeywell recommends that the application circuit designer allow 10 μs after apply voltage has reached its rated value for the output voltage to stabilize

# Micropower Omnipolar Digital Hall-Effect Sensor ICs

**Table 2. Magnetic Characteristics for SL353 Series**  
(2.2 V ≤ V<sub>s</sub> ≤ 5.5 V, -40 °C [-40 °F] ≤ T<sub>a</sub> ≤ 85 °C [185 °F])

Characteristics	Condition	Min.	Typ.	Max.	Unit
Operate point (positive)	V <sub>s</sub> = 2.2 V to 5.5 V, T <sub>a</sub> = -40 °C to 85 °C [-40 °F to 185 °F]	20	60	110	Gauss
Operate point (negative)	V <sub>s</sub> = 2.2 V to 5.5 V, T <sub>a</sub> = -40 °C to 85 °C [-40 °F to 185 °F]	-110	-60	-20	Gauss
Release point (positive)	V <sub>s</sub> = 2.2 V to 5.5 V, T <sub>a</sub> = -40 °C to 85 °C [-40 °F to 185 °F]	5	45	95	Gauss
Release point (negative)	V <sub>s</sub> = 2.2 V to 5.5 V, T <sub>a</sub> = -40 °C to 85 °C [-40 °F to 185 °F]	-95	-45	-5	Gauss
Hysteresis	V <sub>s</sub> = 2.2 V to 5.5 V, T <sub>a</sub> = -40 °C to 85 °C [-40 °F to 185 °F]	3	15	60	Gauss

**Table 3. Absolute Maximum Ratings<sup>2</sup>**

Characteristics	Condition	Min.	Typ.	Max.	Unit
Supply voltage	-	-0.5	-	6	Volts
Operating temperature	Ambient	-40 [-40]	-	150 [302]	°C [°F]
Soldering temperature	Applied for <10 seconds	-	-	265 [509]	°C [°F]
Load current	-	-	-	5	mA

Note 2: The magnetic field strength (Gauss) required to cause the sensor to change state (operate and release) will be as specified in the magnetic characteristics. To test the sensor against the specified magnetic characteristics, the sensor must be placed in a uniform magnetic field

## NOTICE

Absolute maximum ratings are the extreme limits that the device will withstand without damage to the device. However, the electrical and mechanical characteristics are not guaranteed as the maximum limits (above recommended operating conditions) are approached, nor will the device necessary operate at absolute maximum ratings.



Figure 1. Block/Electric Diagram

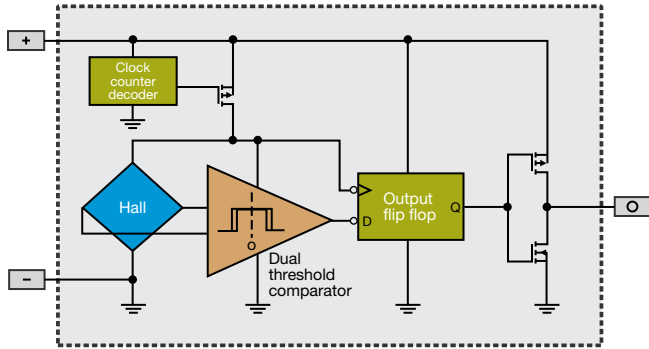

Figure 2. Typical Magnetic Performance vs Temperature

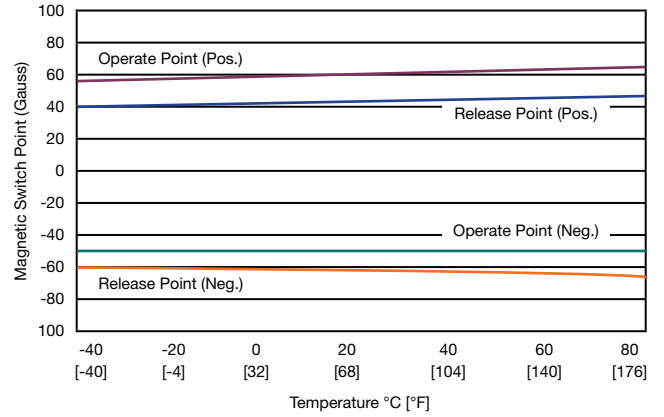

Figure 3. Typical Period vs Temperature

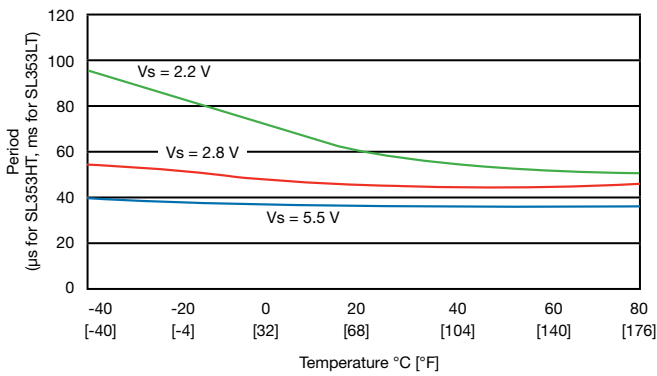

Figure 4. Typical Active Mode Time vs Temperature

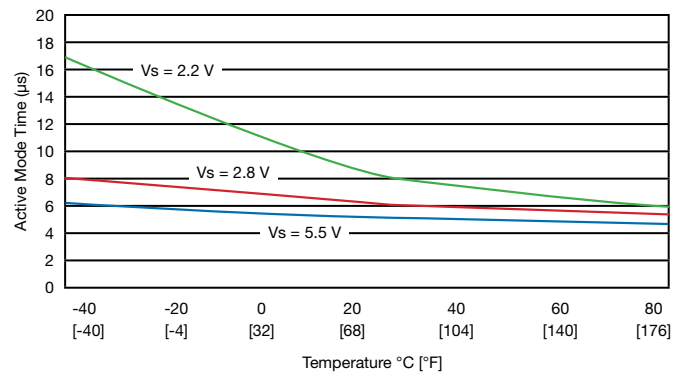

Figure 5. Typical Average Current vs Temperature

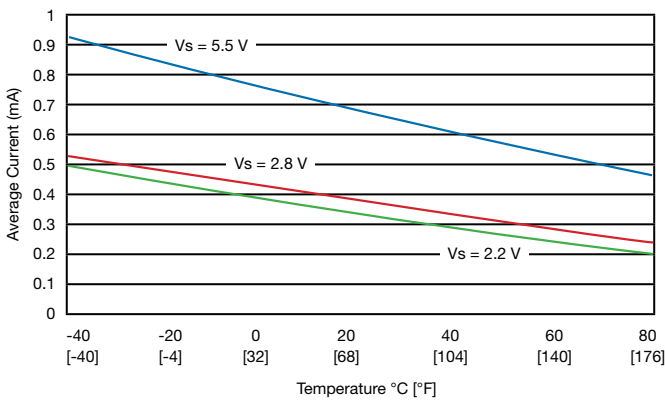
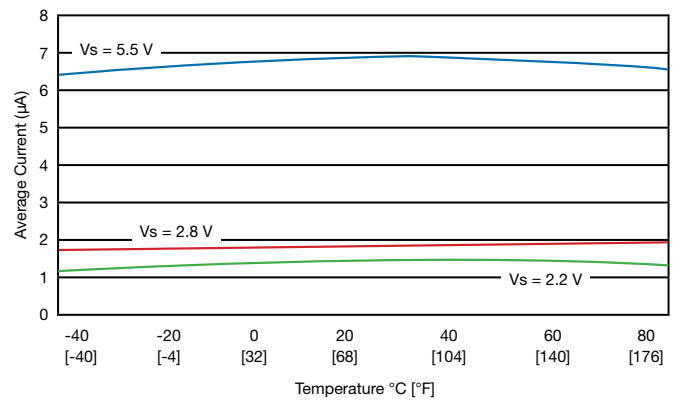

Figure 6. Typical Average Current vs Temperature



# Micropower Omnipolar Digital Hall-Effect Sensor ICs

Figure 7. Package, Tape and Reel Mounting Dimensions (For reference only. mm/in)

## Sensor

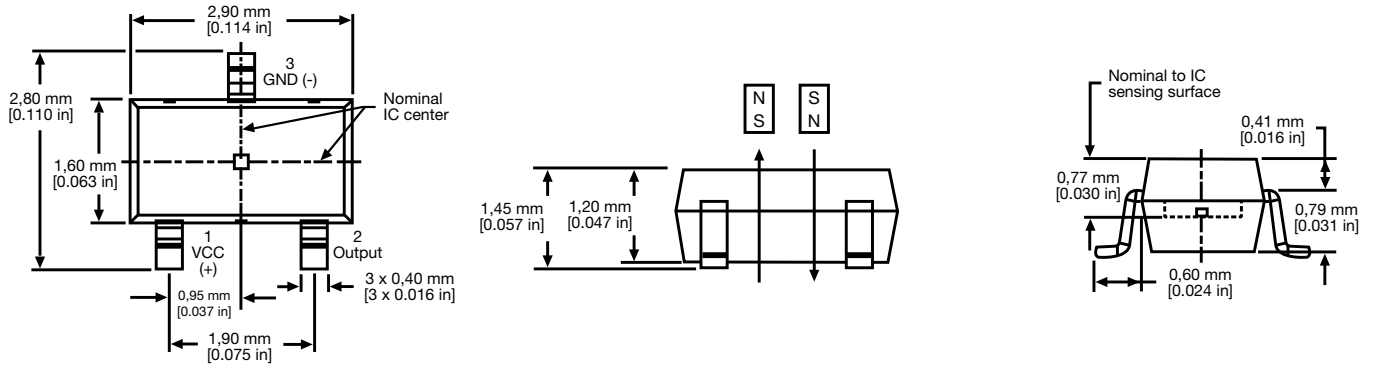

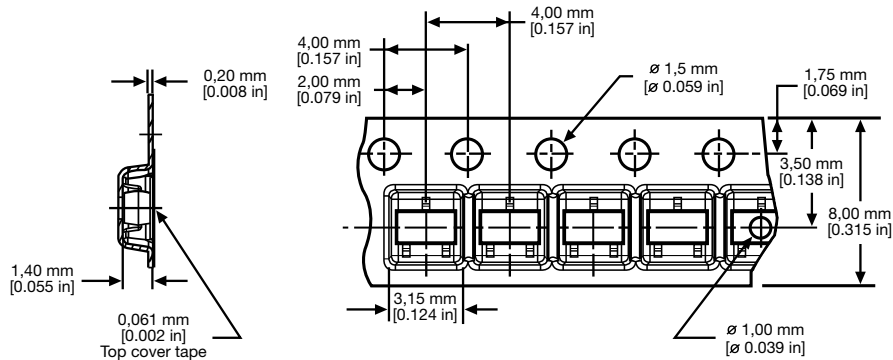

## Tape

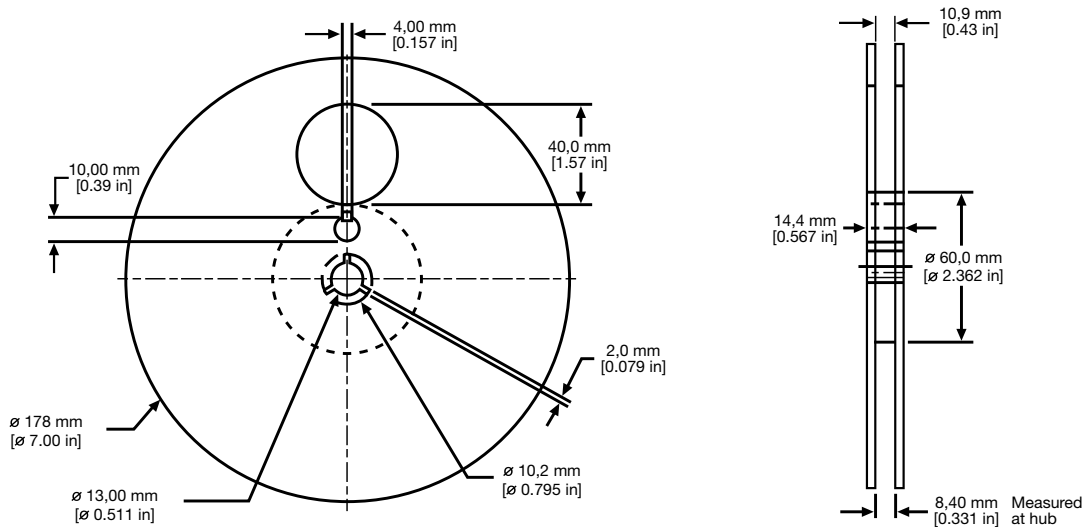

## Reel



## Order Guide (Measurements for reference only)

	Catalog Listing	Packaging Material and Style
	SL353HT	SL353 Series micropower omnipolar digital Hall-effect sensor IC, high-duty cycle, low power (0.33 mA, 2.8 Vdc), SOT-23 package, tape-and-reel packaging (3000 units per reel)
	SL353LT	SL353 Series micropower omnipolar digital Hall-effect sensor IC, low-duty cycle, ultra low power (1.8 µA, 2.8 Vdc), SOT-23 package, tape-and-reel packaging (3000 units per reel)

# SL353 Series

## ADDITIONAL INFORMATION

The following associated literature is available on the Honeywell website at [sensing.honeywell.com](http://sensing.honeywell.com):

- Magnetic sensors line guide
- Product range guide
- Sensors and switches for potential medical applications
- Product installation instructions
- Engineering drawing
- Application note: Shaft Encoding - Tachometer

### **WARNING**

#### **PERSONAL INJURY**

**DO NOT USE** these products as safety or emergency stop devices or in any other application where failure of the product could result in personal injury.

**Failure to comply with these instructions could result in death or serious injury.**

### **WARNING**

#### **MISUSE OF DOCUMENTATION**

- The information presented in this product sheet is for reference only. Do not use this document as a product installation guide.
- Complete installation, operation, and maintenance information is provided in the instructions supplied with each product.

**Failure to comply with these instructions could result in death or serious injury.**

## WARRANTY/REMEDY

Honeywell warrants goods of its manufacture as being free of defective materials and faulty workmanship. Honeywell's standard product warranty applies unless agreed to otherwise by Honeywell in writing; please refer to your order acknowledgement or consult your local sales office for specific warranty details. If warranted goods are returned to Honeywell during the period of coverage, Honeywell will repair or replace, at its option, without charge those items it finds defective. **The foregoing is buyer's sole remedy and is in lieu of all other warranties, expressed or implied, including those of merchantability and fitness for a particular purpose. In no event shall Honeywell be liable for consequential, special, or indirect damages.**

While we provide application assistance personally, through our literature and the Honeywell website, it is up to the customer to determine the suitability of the product in the application.

Specifications may change without notice. The information we supply is believed to be accurate and reliable as of this printing. However, we assume no responsibility for its use.



**Find out more**

Honeywell serves its customers through a worldwide network of sales offices, representatives and distributors. For application assistance, current specifications, pricing or name of the nearest Authorized Distributor, contact your local sales office.

To learn more about Honeywell's sensing and control products, call **+1-815-235-6847** or **1-800-537-6945**, visit **sensing.honeywell.com**, or e-mail inquiries to **info.sc@honeywell.com**

Sensing and Control  
Honeywell  
1985 Douglas Drive North  
Golden Valley, MN 55422  
**honeywell.com**

The Honeywell logo is displayed in a bold, red, sans-serif font.

005935-2-EN IL50 GLO  
March 2014  
Copyright 2014 Honeywell International Inc. All rights reserved.