

(0,80 mm) .0315"

SEM, SEMS, SEML SERIES

MICRO TIGER EYE™ SOCKET

SPECIFICATIONS

For complete specifications and recommended PCB layouts see www.samtec.com?SEM, www.samtec.com?SEMS or www.samtec.com?SEML

Insulator Material: Black Liquid Crystal Polymer
Contact Material: BeCu
Plating: Au or Sn over 50µ" (1,27 µm) Ni
Operating Temp Range: -55°C to +125°C
Current Rating (SEM/TEM): 2,6 A per pin (1 pin powered per row)
RoHS Compliant: Yes

Processing:
Lead-Free Solderable: Yes
SMT Lead Coplanarity: (0,10 mm) .004" max

SEM, SEML Mates with: TEM

SEMS Mates with: TEMS



TEM/SEM 6 mm Stack Height	Rated @ 3dB Insertion Loss*
Single-Ended Signaling	12 GHz / 24 Gbps
Differential Pair Signaling	17 GHz / 34 Gbps

*Test board losses de-embedded from performance data.
 Complete test data available at www.samtec.com?SEM or contact sig@samtec.com

High reliability Tiger Eye™ contacts

Choice of mated heights



- Passes 10 year MFG
- Locking clip option
- Weld tab option

ALSO AVAILABLE (MOQ Required)

- Other sizes
 - Other platings
- Contact Samtec.

28+ Gbps

Weld tab

RECOGNITIONS

For complete scope of recognitions see www.samtec.com/quality



OTHER SOLUTIONS

- (1,27 mm) .050" board-to-board and cable-to-board Tiger Eye™ systems available.
 - Board Stacking: See SFM, TFM Series
 - Cable Assemblies: See SFSD, TFSD Series
- Contact Samtec.



SEM = Tiger Eye™ Strip	SEMS = Tiger Eye™ Slim Strip	SEML = Tiger Eye™ Friction Lock	NO. PINS PER ROW 05, 10, 15, 20, 25 30, 35, 40, 45, 50 (SEM/SEML only) (Standard sizes)	STACK HEIGHT -03.0 = 6 mm, 7 mm or 10 mm Stack Height when mated with TEM/TEMS Series (SEML only available with 6 mm Stack Height)	PLATING OPTION -FG = Gold Flash -G = 10µ" (0,25 µm) Gold on contact, Gold Flash on tail -H = 30µ" (0,76 µm) Gold on contact, Gold Flash on tail	D Leave blank for SEMS	OPTION -A = Alignment Pin (Not available with -LC or -WT) -LC = Locking Clip (Not available with -A or -WT) (Manual placement required) -WT = Weld Tab (Not available with -A or -LC) (Required callout for SEML)	OTHER OPTION -K = (3,50 mm) .138" DIA Polyimide film Pick & Place Pad (Required for SEMS) -TR = Tape & Reel (Required for SEMS)
----------------------------------	--	---	--	--	---	----------------------------------	---	--

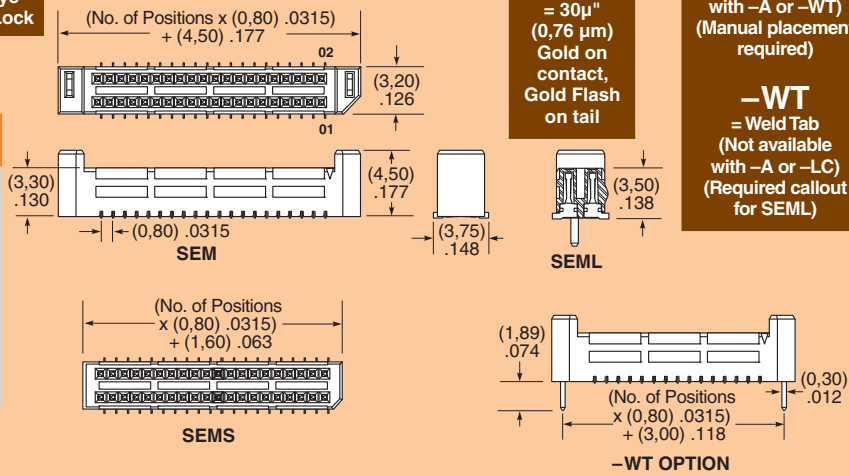

MATED HEIGHT

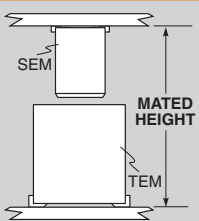

TEM LEAD STYLE	MATED HEIGHT*
-03.0	6 mm
-04.0	7 mm
-07.0	10 mm

*Processing conditions will affect mated height.

Note: Some sizes, styles and options are non-standard, non-returnable.

Due to technical progress, all designs, specifications and components are subject to change without notice.

WWW.SAMTEC.COM