

## Kinetis K22F 512KB Flash

### 120 MHz Cortex-M4 Based Microcontroller with FPU

Ideal for low-power applications that require processing efficiency. Shares the comprehensive enablement and scalability of the Kinetis family.

This product offers:

- Run power consumption down to 180  $\mu$ A/MHz.
- Static power consumption down to 4.5  $\mu$ A, full state retention and 6  $\mu$ S wakeup. Lowest Static mode down to 180 nA.
- High Flash to RAM ratio, with 128 KB of embedded SRAM to support wireless communication, RTOS and other software stacks.
- USB LS/FS OTG 2.0 with embedded 3.3 V, 120 mA LDO voltage regulator.

**MK22FN512VDC12**  
**MK22FN512VLL12**  
**MK22FN512VLH12**  
**MK22FN512VMP12**

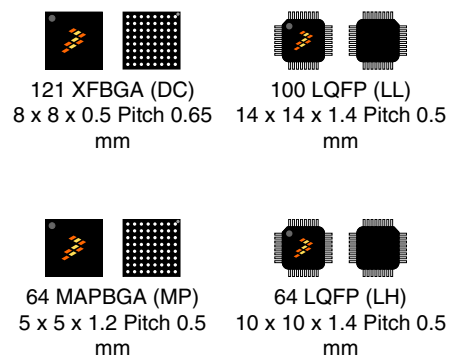

#### Performance

- 120 MHz ARM Cortex-M4 core with DSP instructions delivering 1.25 Dhrystone MIPS per MHz

#### Memories and memory interfaces

- 512 KB of embedded flash and 128 KB of RAM
- FlexBus external bus interface
- Serial programming interface (EzPort)

#### System peripherals

- Flexible low-power modes, multiple wake up sources
- 16-channel DMA controller
- Independent External and Software Watchdog monitor

#### Clocks

- Two crystal oscillators: 32 kHz (RTC) and 32-40 kHz or 3-32 MHz
- Three internal oscillators: 32 kHz, 4 MHz, and 48 MHz
- Multi-purpose clock generator with PLL and FLL

#### Security and integrity modules

- Hardware CRC module
- 128-bit unique identification (ID) number per chip
- Flash access control to protect proprietary software

#### Human-machine interface

- Up to 81 general-purpose I/O

#### Analog modules

- Two 16-bit SAR ADCs converting at 1.2 MS/s in 12bit mode
- Two 12-bit DACs
- Two analog comparators (CMP) with 6-bit DAC
- Accurate internal voltage reference

#### Communication interfaces

- USB full/low-speed On-the-Go controller with on-chip transceiver with 120 mA USB LDO voltage regulator
- Two SPI modules
- Three UART modules and one low-power UART
- Two I2C: Support for up to 400 Kbit/s operation
- I2S module

#### Timers

- Two 8-ch motor control/general purpose/PWM timers
- Two 2-ch motor control/general purpose timers with quadrature decoder functionality
- Periodic interrupt timers
- 16-bit low-power timer
- Real-time clock with independent power domain
- Programmable delay block

#### Operating Characteristics

- Voltage range: 1.71 to 3.6 V
- Temperature range (ambient): -40 to 105°C

### Ordering Information

Part Number	Memory		Maximum number of I/O's
	Flash (KB)	SRAM (KB)	
MK22FN512VDC12	512	128	81
MK22FN512VLL12	512	128	66
MK22FN512VLH12	512	128	40
MK22FN512VMP12	512	128	40

### Related Resources

Type	Description
Selector Guide	The Freescale Solution Advisor is a web-based tool that features interactive application wizards and a dynamic product selector.
Product Brief	The Product Brief contains concise overview/summary information to enable quick evaluation of a device for design suitability.
Reference Manual	The Reference Manual contains a comprehensive description of the structure and function (operation) of a device.
Data Sheet	The Data Sheet includes electrical characteristics and signal connections.
Chip Errata	The chip mask set Errata provides additional or corrective information for a particular device mask set.
Package drawing	Package dimensions are provided in package drawings.

Figure 1 shows the functional modules in the chip.

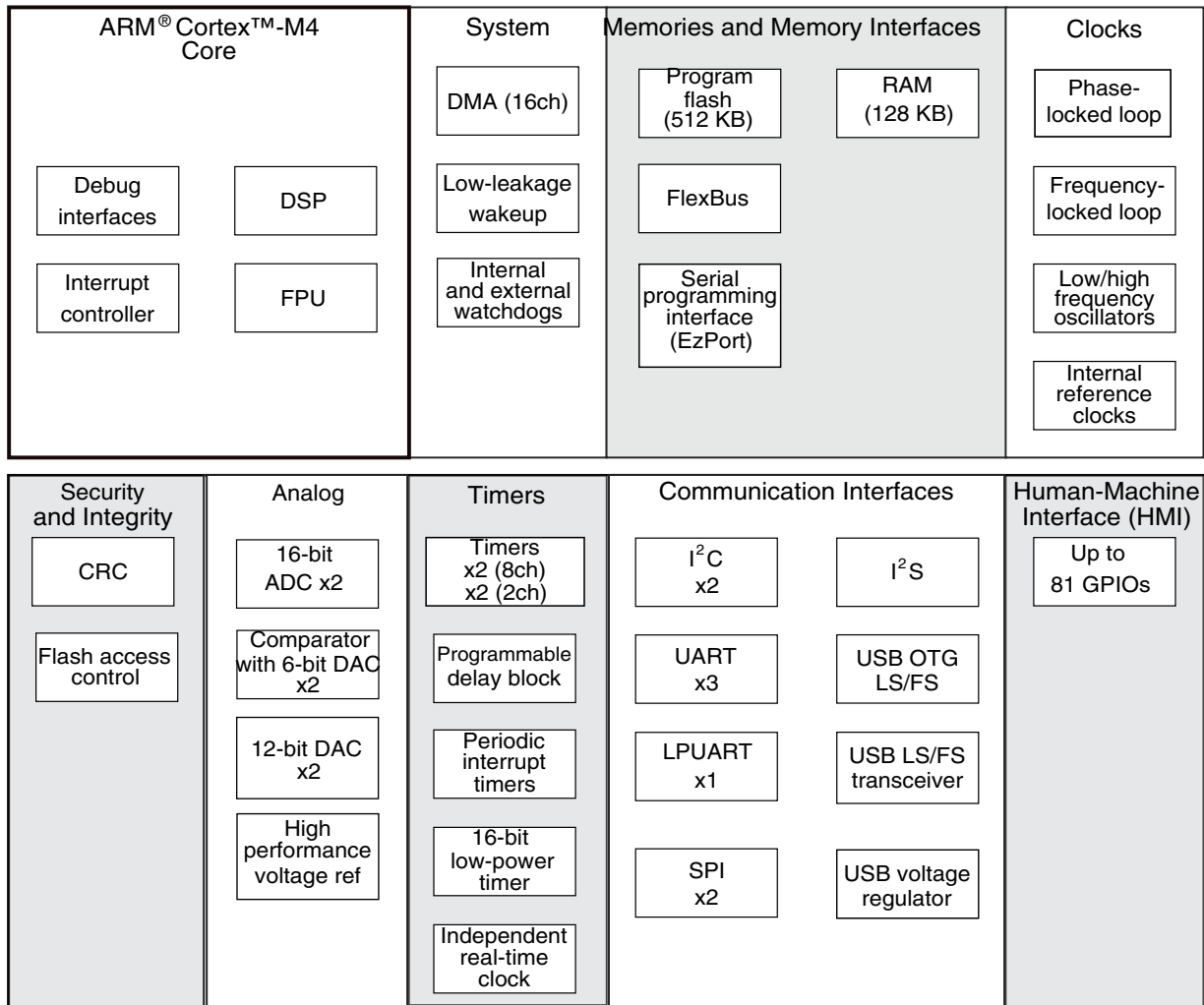

**Figure 1. Functional block diagram**

# Table of Contents

1	Ratings.....	5	3.4.2	EzPort switching specifications.....	31
1.1	Thermal handling ratings.....	5	3.4.3	Flexbus switching specifications.....	32
1.2	Moisture handling ratings.....	5	3.5	Security and integrity modules.....	35
1.3	ESD handling ratings.....	5	3.6	Analog.....	35
1.4	Voltage and current operating ratings.....	5	3.6.1	ADC electrical specifications.....	36
2	General.....	6	3.6.2	CMP and 6-bit DAC electrical specifications.....	40
2.1	AC electrical characteristics.....	6	3.6.3	12-bit DAC electrical characteristics.....	42
2.2	Nonswitching electrical specifications.....	6	3.6.4	Voltage reference electrical specifications.....	45
2.2.1	Voltage and current operating requirements.....	6	3.7	Timers.....	46
2.2.2	LVD and POR operating requirements.....	7	3.8	Communication interfaces.....	46
2.2.3	Voltage and current operating behaviors.....	8	3.8.1	USB electrical specifications.....	47
2.2.4	Power mode transition operating behaviors.....	9	3.8.2	USB VREG electrical specifications.....	47
2.2.5	Power consumption operating behaviors.....	10	3.8.3	DSPI switching specifications (limited voltage range).....	47
2.2.6	EMC radiated emissions operating behaviors.....	15	3.8.4	DSPI switching specifications (full voltage range).....	49
2.2.7	Designing with radiated emissions in mind.....	16	3.8.5	Inter-Integrated Circuit Interface (I2C) timing.....	51
2.2.8	Capacitance attributes.....	16	3.8.6	UART switching specifications.....	52
2.3	Switching specifications.....	16	3.8.7	I2S/SAI switching specifications.....	52
2.3.1	Device clock specifications.....	16	4	Dimensions.....	58
2.3.2	General switching specifications.....	17	4.1	Obtaining package dimensions.....	58
2.4	Thermal specifications.....	18	5	Pinout.....	59
2.4.1	Thermal operating requirements.....	18	5.1	K22F Signal Multiplexing and Pin Assignments.....	59
2.4.2	Thermal attributes.....	18	5.2	K22 Pinouts.....	64
3	Peripheral operating requirements and behaviors.....	19	6	Ordering parts.....	68
3.1	Core modules.....	19	6.1	Determining valid orderable parts.....	68
3.1.1	SWD electricals.....	20	7	Part identification.....	69
3.1.2	JTAG electricals.....	21	7.1	Description.....	69
3.2	System modules.....	24	7.2	Format.....	69
3.3	Clock modules.....	24	7.3	Fields.....	69
3.3.1	MCG specifications.....	24	7.4	Example.....	70
3.3.2	IRC48M specifications.....	26	7.5	121-pin XFBGA part marking.....	70
3.3.3	Oscillator electrical specifications.....	27	7.6	64-pin MAPBGA part marking.....	70
3.3.4	32 kHz oscillator electrical characteristics.....	29	8	Revision History.....	71
3.4	Memories and memory interfaces.....	30			
3.4.1	Flash electrical specifications.....	30			

# 1 Ratings

## 1.1 Thermal handling ratings

Symbol	Description	Min.	Max.	Unit	Notes
T <sub>STG</sub>	Storage temperature	-55	150	°C	1
T <sub>SDR</sub>	Solder temperature, lead-free	—	260	°C	2

1. Determined according to JEDEC Standard JESD22-A103, *High Temperature Storage Life*.
2. Determined according to IPC/JEDEC Standard J-STD-020, *Moisture/Reflow Sensitivity Classification for Nonhermetic Solid State Surface Mount Devices*.

## 1.2 Moisture handling ratings

Symbol	Description	Min.	Max.	Unit	Notes
MSL	Moisture sensitivity level	—	3	—	1

1. Determined according to IPC/JEDEC Standard J-STD-020, *Moisture/Reflow Sensitivity Classification for Nonhermetic Solid State Surface Mount Devices*.

## 1.3 ESD handling ratings

Symbol	Description	Min.	Max.	Unit	Notes
V <sub>HBM</sub>	Electrostatic discharge voltage, human body model	-2000	+2000	V	1
V <sub>CDM</sub>	Electrostatic discharge voltage, charged-device model	-500	+500	V	2
I <sub>LAT</sub>	Latch-up current at ambient temperature of 105°C	-100	+100	mA	3

1. Determined according to JEDEC Standard JESD22-A114, *Electrostatic Discharge (ESD) Sensitivity Testing Human Body Model (HBM)*.
2. Determined according to JEDEC Standard JESD22-C101, *Field-Induced Charged-Device Model Test Method for Electrostatic-Discharge-Withstand Thresholds of Microelectronic Components*.
3. Determined according to JEDEC Standard JESD78, *IC Latch-Up Test*.

## 1.4 Voltage and current operating ratings

## General

Symbol	Description	Min.	Max.	Unit
$V_{DD}$	Digital supply voltage	-0.3	3.8	V
$I_{DD}$	Digital supply current	—	169	mA
$V_{DIO}$	Digital input voltage	-0.3	$V_{DD} + 0.3$	V
$V_{AIO}$	Analog <sup>1</sup>	-0.3	$V_{DD} + 0.3$	V
$I_D$	Maximum current single pin limit (applies to all digital pins)	-25	25	mA
$V_{DDA}$	Analog supply voltage	$V_{DD} - 0.3$	$V_{DD} + 0.3$	V
$V_{USB0\_DP}$	USB0_DP input voltage	-0.3	3.63	V
$V_{USB0\_DM}$	USB0_DM input voltage	-0.3	3.63	V
VREGIN	USB regulator input	-0.3	6.0	V
$V_{BAT}$	RTC battery supply voltage	-0.3	3.8	V

1. Analog pins are defined as pins that do not have an associated general purpose I/O port function.

## 2 General

### 2.1 AC electrical characteristics

Unless otherwise specified, propagation delays are measured from the 50% to the 50% point, and rise and fall times are measured at the 20% and 80% points, as shown in the following figure.

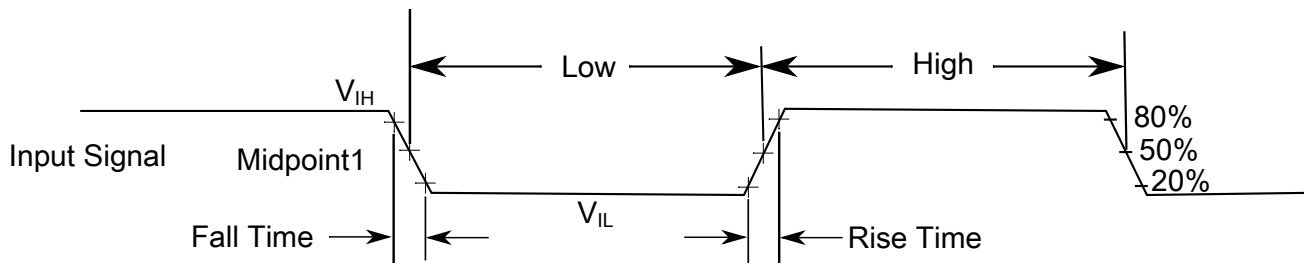

The midpoint is  $V_{IL} + (V_{IH} - V_{IL}) / 2$

**Figure 2. Input signal measurement reference**

### 2.2 Nonswitching electrical specifications

## 2.2.1 Voltage and current operating requirements

**Table 1. Voltage and current operating requirements**

Symbol	Description	Min.	Max.	Unit	Notes
V <sub>DD</sub>	Supply voltage	1.71	3.6	V	
V <sub>DDA</sub>	Analog supply voltage	1.71	3.6	V	
V <sub>DD</sub> – V <sub>DDA</sub>	V <sub>DD</sub> -to-V <sub>DDA</sub> differential voltage	–0.1	0.1	V	
V <sub>SS</sub> – V <sub>SSA</sub>	V <sub>SS</sub> -to-V <sub>SSA</sub> differential voltage	–0.1	0.1	V	
V <sub>BAT</sub>	RTC battery supply voltage	1.71	3.6	V	
V <sub>IH</sub>	Input high voltage <ul style="list-style-type: none"> <li>• 2.7 V ≤ V<sub>DD</sub> ≤ 3.6 V</li> <li>• 1.7 V ≤ V<sub>DD</sub> ≤ 2.7 V</li> </ul>	0.7 × V <sub>DD</sub>	—	V	
		0.75 × V <sub>DD</sub>	—	V	
V <sub>IL</sub>	Input low voltage <ul style="list-style-type: none"> <li>• 2.7 V ≤ V<sub>DD</sub> ≤ 3.6 V</li> <li>• 1.7 V ≤ V<sub>DD</sub> ≤ 2.7 V</li> </ul>	—	0.35 × V <sub>DD</sub>	V	
		—	0.3 × V <sub>DD</sub>	V	
V <sub>HYS</sub>	Input hysteresis	0.06 × V <sub>DD</sub>	—	V	
I <sub>ICIO</sub>	Analog and I/O pin DC injection current — single pin <ul style="list-style-type: none"> <li>• V<sub>IN</sub> &lt; V<sub>SS</sub>-0.3V (Negative current injection)</li> <li>• V<sub>IN</sub> &gt; V<sub>DD</sub>+0.3V (Positive current injection)</li> </ul>	-3 —	— +3	mA	1
I <sub>ICcont</sub>	Contiguous pin DC injection current — regional limit, includes sum of negative injection currents or sum of positive injection currents of 16 contiguous pins <ul style="list-style-type: none"> <li>• Negative current injection</li> <li>• Positive current injection</li> </ul>	-25 —	— +25	mA	
V <sub>ODPU</sub>	Open drain pullup voltage level	V <sub>DD</sub>	V <sub>DD</sub>	V	2
V <sub>RAM</sub>	V <sub>DD</sub> voltage required to retain RAM	1.2	—	V	
V <sub>RFVBAT</sub>	V <sub>BAT</sub> voltage required to retain the VBAT register file	V <sub>POR_VBAT</sub>	—	V	

- All analog and I/O pins are internally clamped to V<sub>SS</sub> and V<sub>DD</sub> through ESD protection diodes. If V<sub>IN</sub> is less than V<sub>IO\_MIN</sub> or greater than V<sub>IO\_MAX</sub>, a current limiting resistor is required. The negative DC injection current limiting resistor is calculated as  $R=(V_{IO\_MIN}-V_{IN})/|I_{ICIO}|$ . The positive injection current limiting resistor is calculated as  $R=(V_{IN}-V_{IO\_MAX})/|I_{ICIO}|$ . Select the larger of these two calculated resistances if the pin is exposed to positive and negative injection currents.
- Open drain outputs must be pulled to V<sub>DD</sub>.

## 2.2.2 LVD and POR operating requirements

**Table 2. V<sub>DD</sub> supply LVD and POR operating requirements**

Symbol	Description	Min.	Typ.	Max.	Unit	Notes
V <sub>POR</sub>	Falling V <sub>DD</sub> POR detect voltage	0.8	1.1	1.5	V	

*Table continues on the next page...*

**Table 2. V<sub>DD</sub> supply LVD and POR operating requirements (continued)**

Symbol	Description	Min.	Typ.	Max.	Unit	Notes
V <sub>LVDH</sub>	Falling low-voltage detect threshold — high range (LVDV=01)	2.48	2.56	2.64	V	
V <sub>LVW1H</sub>	Low-voltage warning thresholds — high range <ul style="list-style-type: none"> <li>• Level 1 falling (LVWV=00)</li> <li>• Level 2 falling (LVWV=01)</li> <li>• Level 3 falling (LVWV=10)</li> <li>• Level 4 falling (LVWV=11)</li> </ul>	2.62	2.70	2.78	V	1
V <sub>LVW2H</sub>		2.72	2.80	2.88	V	
V <sub>LVW3H</sub>		2.82	2.90	2.98	V	
V <sub>LVW4H</sub>		2.92	3.00	3.08	V	
V <sub>HYSH</sub>	Low-voltage inhibit reset/recover hysteresis — high range	—	80	—	mV	
V <sub>LVDL</sub>	Falling low-voltage detect threshold — low range (LVDV=00)	1.54	1.60	1.66	V	
V <sub>LVW1L</sub>	Low-voltage warning thresholds — low range <ul style="list-style-type: none"> <li>• Level 1 falling (LVWV=00)</li> <li>• Level 2 falling (LVWV=01)</li> <li>• Level 3 falling (LVWV=10)</li> <li>• Level 4 falling (LVWV=11)</li> </ul>	1.74	1.80	1.86	V	1,
V <sub>LVW2L</sub>		1.84	1.90	1.96	V	
V <sub>LVW3L</sub>		1.94	2.00	2.06	V	
V <sub>LVW4L</sub>		2.04	2.10	2.16	V	
V <sub>HYSL</sub>	Low-voltage inhibit reset/recover hysteresis — low range	—	60	—	mV	
V <sub>BG</sub>	Bandgap voltage reference	0.97	1.00	1.03	V	
t <sub>LPO</sub>	Internal low power oscillator period — factory trimmed	900	1000	1100	μs	

1. Rising threshold is the sum of falling threshold and hysteresis voltage

**Table 3. VBAT power operating requirements**

Symbol	Description	Min.	Typ.	Max.	Unit	Notes
V <sub>POR_VBAT</sub>	Falling VBAT supply POR detect voltage	0.8	1.1	1.5	V	

## 2.2.3 Voltage and current operating behaviors

**Table 4. Voltage and current operating behaviors**

Symbol	Description	Min.	Typ.	Max.	Unit	Notes
V <sub>OH</sub>	Output high voltage — Normal drive pad <ul style="list-style-type: none"> <li>• 2.7 V ≤ V<sub>DD</sub> ≤ 3.6 V, I<sub>OH</sub> = -5 mA</li> <li>• 1.71 V ≤ V<sub>DD</sub> ≤ 2.7 V, I<sub>OH</sub> = -2.5 mA</li> </ul>	V <sub>DD</sub> - 0.5	—	—	V	1
		V <sub>DD</sub> - 0.5	—	—	V	
		V <sub>DD</sub> - 0.5	—	—	V	
V <sub>OH</sub>	Output high voltage — High drive pad	V <sub>DD</sub> - 0.5	—	—	V	1

Table continues on the next page...



**Table 4. Voltage and current operating behaviors (continued)**

Symbol	Description	Min.	Typ.	Max.	Unit	Notes
	<ul style="list-style-type: none"> <li>• <math>2.7\text{ V} \leq V_{DD} \leq 3.6\text{ V}</math>, <math>I_{OH} = -20\text{ mA}</math></li> <li>• <math>1.71\text{ V} \leq V_{DD} \leq 2.7\text{ V}</math>, <math>I_{OH} = -10\text{ mA}</math></li> </ul>	$V_{DD} - 0.5$	—	—	V	
$I_{OHT}$	Output high current total for all ports	—	—	100	mA	
$V_{OL}$	Output low voltage — Normal drive pad <ul style="list-style-type: none"> <li>• <math>2.7\text{ V} \leq V_{DD} \leq 3.6\text{ V}</math>, <math>I_{OL} = 5\text{ mA}</math></li> <li>• <math>1.71\text{ V} \leq V_{DD} \leq 2.7\text{ V}</math>, <math>I_{OL} = 2.5\text{ mA}</math></li> </ul>	—	—	0.5	V	1
$V_{OL}$	Output low voltage — High drive pad <ul style="list-style-type: none"> <li>• <math>2.7\text{ V} \leq V_{DD} \leq 3.6\text{ V}</math>, <math>I_{OL} = 20\text{ mA}</math></li> <li>• <math>1.71\text{ V} \leq V_{DD} \leq 2.7\text{ V}</math>, <math>I_{OL} = 10\text{ mA}</math></li> </ul>	—	—	0.5	V	1
$I_{OLT}$	Output low current total for all ports	—	—	100	mA	
$I_{IN}$	Input leakage current (per pin) for full temperature range <ul style="list-style-type: none"> <li>• All pins other than high drive port pins</li> <li>• High drive port pins</li> </ul>	—	0.002	0.5	$\mu\text{A}$	1, 2
$I_{IN}$	Input leakage current (total all pins) for full temperature range	—	—	1.0	$\mu\text{A}$	2
$R_{PU}$	Internal pullup resistors	20	—	50	k $\Omega$	3
$R_{PD}$	Internal pulldown resistors	20	—	50	k $\Omega$	4

1. PTB0, PTB1, PTC3, PTC4, PTD4, PTD5, PTD6, and PTD7 I/O have both high drive and normal drive capability selected by the associated PTx\_PCRn[DSE] control bit. All other GPIOs are normal drive only.
2. Measured at  $V_{DD}=3.6\text{V}$
3. Measured at  $V_{DD}$  supply voltage =  $V_{DD}$  min and  $V_{input} = V_{SS}$
4. Measured at  $V_{DD}$  supply voltage =  $V_{DD}$  min and  $V_{input} = V_{DD}$

## 2.2.4 Power mode transition operating behaviors

All specifications except  $t_{POR}$ , and  $VLLSx \rightarrow \text{RUN}$  recovery times in the following table assume this clock configuration:

- CPU and system clocks = 80 MHz
- Bus clock = 40 MHz
- FlexBus clock = 20 MHz
- Flash clock = 20 MHz
- MCG mode: FEI

**Table 5. Power mode transition operating behaviors**

Symbol	Description	Min.	Typ.	Max.	Unit	Notes
$t_{POR}$	After a POR event, amount of time from the point $V_{DD}$ reaches 1.71 V to execution of the first instruction across the operating temperature range of the chip.	—	—	300	$\mu s$	1
	• VLLS0 → RUN	—	—	140	$\mu s$	
	• VLLS1 → RUN	—	—	140	$\mu s$	
	• VLLS2 → RUN	—	—	80	$\mu s$	
	• VLLS3 → RUN	—	—	80	$\mu s$	
	• LLS2 → RUN	—	—	6	$\mu s$	
	• LLS3 → RUN	—	—	6	$\mu s$	
	• VLPS → RUN	—	—	5.7	$\mu s$	
	• STOP → RUN	—	—	5.7	$\mu s$	

1. Normal boot (FTFA\_OPT[LPBOOT]=1)

## 2.2.5 Power consumption operating behaviors

**Table 6. Power consumption operating behaviors**

Symbol	Description	Min.	Typ.	Max.	Unit	Notes
$I_{DDA}$	Analog supply current	—	—	See note	mA	1
$I_{DD\_HSRUN}$	High Speed Run mode current — all peripheral clocks disabled, code executing from flash	—	25.6	—	mA	2
		—	25.7	—	mA	
$I_{DD\_HSRUN}$	High Speed Run mode current — all peripheral clocks enabled, code executing from flash	—	35.5	—	mA	3
		—	35.6	—	mA	
$I_{DD\_RUN}$	Run mode current — all peripheral clocks disabled, code executing from flash					4

Table continues on the next page...

**Table 6. Power consumption operating behaviors (continued)**

Symbol	Description	Min.	Typ.	Max.	Unit	Notes
	<ul style="list-style-type: none"> <li>• @ 1.8V</li> <li>• @ 3.0V</li> </ul>	—	16.6	—	mA	
		—	16.8	—	mA	
I <sub>DD_RUN</sub>	Run mode current — all peripheral clocks enabled, code executing from flash <ul style="list-style-type: none"> <li>• @ 1.8V</li> <li>• @ 3.0V <ul style="list-style-type: none"> <li>• @ 25°C</li> <li>• @ 125°C</li> </ul> </li> </ul>	—	22.8	—	mA	5
		—	22.9	—	mA	
		—	24.1	—	mA	
I <sub>DD_RUN</sub>	Run mode current — Compute Operation, code executing from flash <ul style="list-style-type: none"> <li>• @ 1.8V</li> <li>• @ 3.0V <ul style="list-style-type: none"> <li>• @ 25°C</li> <li>• @ 125°C</li> </ul> </li> </ul>	—	15.1	—	mA	6
		—	15.1	—	mA	
		—	16.3	—	mA	
I <sub>DD_WAIT</sub>	Wait mode high frequency current at 3.0 V — all peripheral clocks disabled	—	9.3	—	mA	4
I <sub>DD_WAIT</sub>	Wait mode reduced frequency current at 3.0 V — all peripheral clocks disabled	—	5.4	—	mA	7
I <sub>DD_VLPR</sub>	Very-low-power run mode current at 3.0 V — all peripheral clocks disabled	—	0.80	—	mA	8
I <sub>DD_VLPR</sub>	Very-low-power run mode current at 3.0 V — all peripheral clocks enabled	—	1.3	—	mA	9
I <sub>DD_VLPR</sub>	Very-low-power run mode current at 3.0 V — Compute Operation	—	0.72	—	mA	10
I <sub>DD_VLPW</sub>	Very-low-power wait mode current at 3.0 V — all peripheral clocks disabled	—	0.45	—	mA	11
I <sub>DD_STOP</sub>	Stop mode current at 3.0 V <ul style="list-style-type: none"> <li>• @ -40 to 25°C</li> <li>• @ 70°C</li> <li>• @ 105°C</li> </ul>	—	0.28	0.46	mA	
		—	0.34	0.68	mA	
		—	0.50	1.1	mA	
I <sub>DD_VLPS</sub>	Very-low-power stop mode current at 3.0 V <ul style="list-style-type: none"> <li>• @ -40 to 25°C</li> <li>• @ 70°C</li> <li>• @ 105°C</li> </ul>	—	9.0	27.5	μA	
		—	31.1	128	μA	
		—	98.6	378	μA	
I <sub>DD_LLS3</sub>	Low leakage stop mode 3 current at 3.0 V <ul style="list-style-type: none"> <li>• @ -40 to 25°C</li> </ul>	—	4.5	7.5	μA	
		—	12.5	45	μA	

Table continues on the next page...

**Table 6. Power consumption operating behaviors (continued)**

Symbol	Description	Min.	Typ.	Max.	Unit	Notes
	<ul style="list-style-type: none"> <li>@ 70°C</li> <li>@ 105°C</li> </ul>	—	39.5	143	μA	
I <sub>DD_LLS2</sub>	Low leakage stop mode 2 current at 3.0 V <ul style="list-style-type: none"> <li>@ -40 to 25°C</li> <li>@ 70°C</li> <li>@ 105°C</li> </ul>	—	3.7	5.2	μA	
		—	7.8	25	μA	
		—	23.6	87	μA	
I <sub>DD_VLLS3</sub>	Very low-leakage stop mode 3 current at 3.0 V <ul style="list-style-type: none"> <li>@ -40 to 25°C</li> <li>@ 70°C</li> <li>@ 105°C</li> </ul>	—	3.0	5.1	μA	
		—	9.5	33	μA	
		—	30.1	102	μA	
I <sub>DD_VLLS2</sub>	Very low-leakage stop mode 2 current at 3.0 V <ul style="list-style-type: none"> <li>@ -40 to 25°C</li> <li>@ 70°C</li> <li>@ 105°C</li> </ul>	—	2.3	3	μA	
		—	4.5	12.5	μA	
		—	13	38	μA	
I <sub>DD_VLLS1</sub>	Very low-leakage stop mode 1 current at 3.0 V <ul style="list-style-type: none"> <li>@ -40 to 25°C</li> <li>@ 70°C</li> <li>@ 105°C</li> </ul>	—	0.86	2.1	μA	
		—	1.7	6	μA	
		—	5.9	15.7	μA	
I <sub>DD_VLLS0</sub>	Very low-leakage stop mode 0 current at 3.0 V with POR detect circuit enabled <ul style="list-style-type: none"> <li>@ -40 to 25°C</li> <li>@ 70°C</li> <li>@ 105°C</li> </ul>	—	0.50	0.675	μA	
		—	1.4	3.5	μA	
		—	5.4	13.2	μA	
I <sub>DD_VLLS0</sub>	Very low-leakage stop mode 0 current at 3.0 V with POR detect circuit disabled <ul style="list-style-type: none"> <li>@ -40 to 25°C</li> <li>@ 70°C</li> <li>@ 105°C</li> </ul>	—	0.18	0.33	μA	
		—	1.1	3.2	μA	
		—	5.1	12.9	μA	
I <sub>DD_VBAT</sub>	Average current with RTC and 32kHz disabled at 3.0 V <ul style="list-style-type: none"> <li>@ -40 to 25°C</li> <li>@ 70°C</li> <li>@ 105°C</li> </ul>	—	0.19	0.22	μA	
		—	0.49	0.64	μA	
		—	2.2	3.2	μA	
I <sub>DD_VBAT</sub>	Average current when CPU is not accessing RTC registers	—	0.57	0.67	μA	12

**Table 6. Power consumption operating behaviors**

Symbol	Description	Min.	Typ.	Max.	Unit	Notes
	• @ 1.8V	—	0.90	1.2	μA	
	• @ -40 to 25°C	—	2.4	3.5	μA	
	• @ 70°C	—	0.67	0.94	μA	
	• @ 105°C	—	1.0	1.4	μA	
	• @ 3.0V	—	2.7	3.9	μA	
	• @ -40 to 25°C	—				
	• @ 70°C	—				
	• @ 105°C	—				

- The analog supply current is the sum of the active or disabled current for each of the analog modules on the device. See each module's specification for its supply current.
- 120MHz core and system clock, 60MHz bus clock, 24MHz FlexBus clock, and 24MHz flash clock. MCG configured for PEE mode. All peripheral clocks disabled.
- 120MHz core and system clock, 60MHz bus clock, 24MHz FlexBus clock, and 24MHz flash clock. MCG configured for PEE mode. All peripheral clocks enabled.
- 80MHz core and system clock, 40MHz bus clock, 20MHz FlexBus clock, and 26.67MHz flash clock. MCG configured for FEI mode. All peripheral clocks disabled.
- 80MHz core and system clock, 40MHz bus clock, 20MHz FlexBus clock, and 26.67MHz flash clock. MCG configured for FEI mode. All peripheral clocks enabled.
- 80MHz core and system clock, 40MHz bus clock, and 26.67MHz flash clock. MCG configured for FEI mode. Compute Operation.
- 25MHz core and system clock, 25MHz bus clock, and 25MHz FlexBus and flash clock. MCG configured for FEI mode.
- 4 MHz core, system, FlexBus, and bus clock and 1MHz flash clock. MCG configured for BLPE mode. All peripheral clocks disabled. Code executing from flash.
- 4 MHz core, system, FlexBus, and bus clock and 1MHz flash clock. MCG configured for BLPE mode. All peripheral clocks enabled but peripherals are not in active operation. Code executing from flash.
- 4 MHz core, system, FlexBus, and bus clock and 1MHz flash clock. MCG configured for BLPE mode. Compute Operation. Code executing from flash.
- 4 MHz core, system, FlexBus, and bus clock and 1MHz flash clock. MCG configured for BLPE mode. All peripheral clocks disabled.
- Includes 32kHz oscillator current and RTC operation.

### 2.2.5.1 Diagram: Typical IDD\_RUN operating behavior

The following data was measured under these conditions:

- MCG in FBE mode for 50 MHz and lower frequencies. MCG in FEE mode at frequencies between 50 MHz and 100MHz. MCG in PEE mode at frequencies greater than 100 MHz.
- USB regulator disabled
- No GPIOs toggled
- Code execution from flash with cache enabled
- For the ALLOFF curve, all peripheral clocks are disabled except FTFA

General

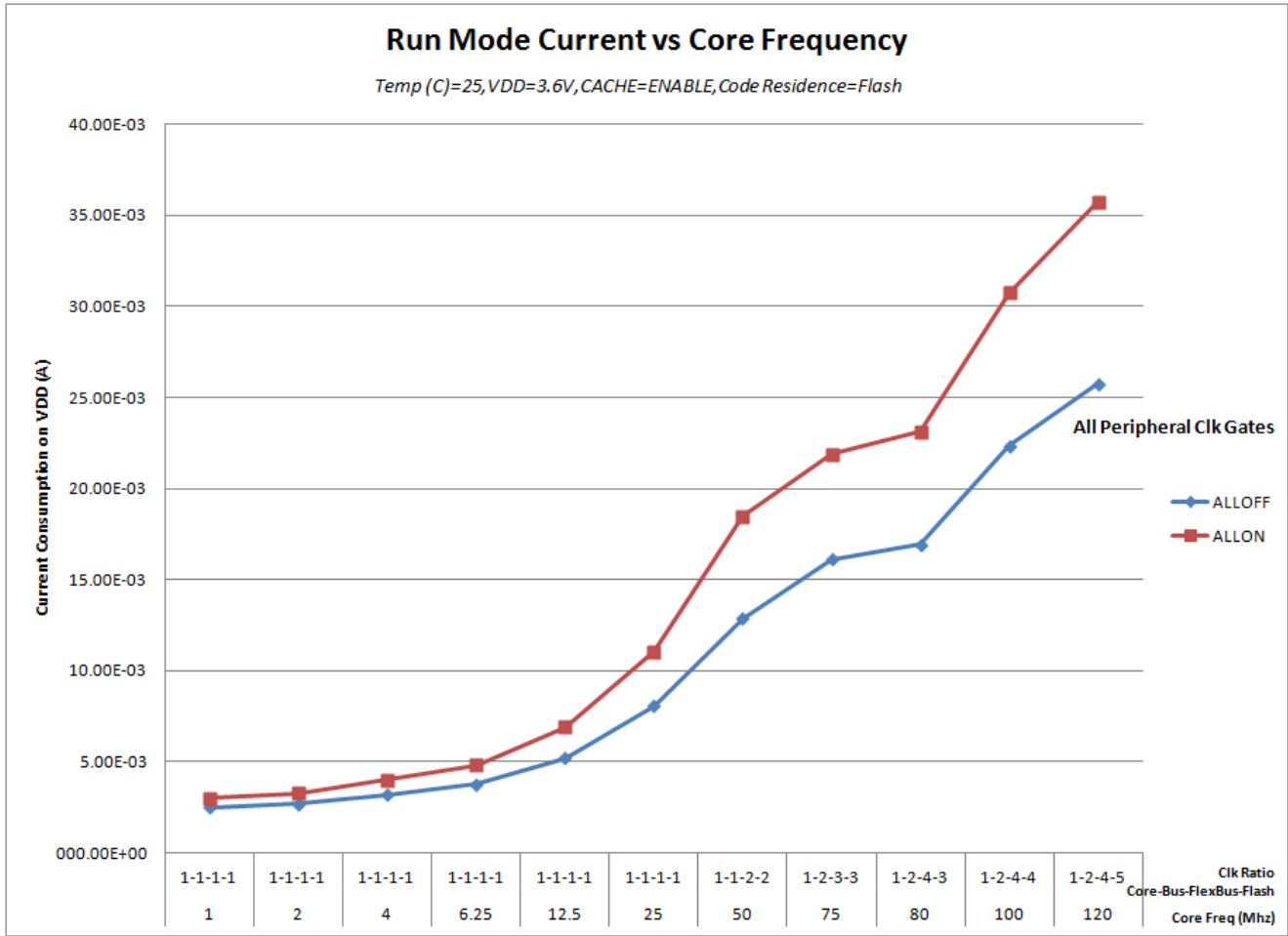

Figure 3. Run mode supply current vs. core frequency

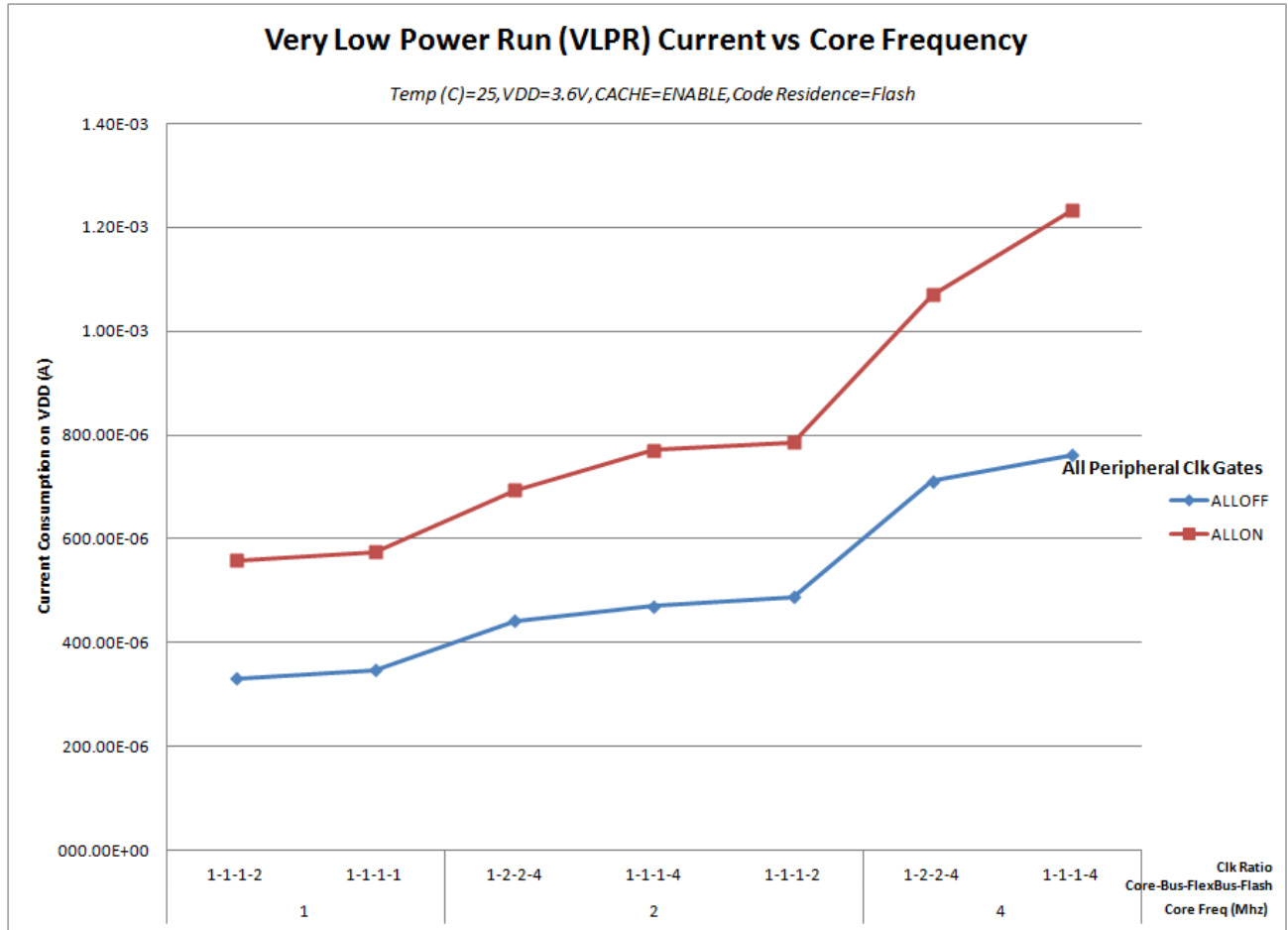

Figure 4. VLPR mode supply current vs. core frequency

## 2.2.6 EMC radiated emissions operating behaviors

Table 7. EMC radiated emissions operating behaviors for 64 LQFP package

Symbol	Description	Frequency band (MHz)	Typ.	Unit	Notes
V <sub>RE1</sub>	Radiated emissions voltage, band 1	0.15–50	14	dB $\mu$ V	1, 2
V <sub>RE2</sub>	Radiated emissions voltage, band 2	50–150	23	dB $\mu$ V	
V <sub>RE3</sub>	Radiated emissions voltage, band 3	150–500	23	dB $\mu$ V	
V <sub>RE4</sub>	Radiated emissions voltage, band 4	500–1000	9	dB $\mu$ V	
V <sub>RE_JEC</sub>	IEC level	0.15–1000	L	—	2, 3, 4

1. Determined according to IEC Standard 61967-1, *Integrated Circuits - Measurement of Electromagnetic Emissions, 150 kHz to 1 GHz Part 1: General Conditions and Definitions* and IEC Standard 61967-2, *Integrated Circuits - Measurement of Electromagnetic Emissions, 150 kHz to 1 GHz Part 2: Measurement of Radiated Emissions—TEM Cell and Wideband TEM Cell Method*. Measurements were made while the microcontroller was running basic

## General

application code. The reported emission level is the value of the maximum measured emission, rounded up to the next whole number, from among the measured orientations in each frequency range.

2.  $V_{DD} = 3.3\text{ V}$ ,  $T_A = 25\text{ }^\circ\text{C}$ ,  $f_{OSC} = 8\text{ MHz}$  (crystal),  $f_{SYS} = 120\text{ MHz}$ ,  $f_{BUS} = 60\text{ MHz}$
3. Specified according to Annex D of IEC Standard 61967-2, *Measurement of Radiated Emissions—TEM Cell and Wideband TEM Cell Method*.
4. IEC Level Maximums: M  $\leq 18\text{ dBmV}$ , L  $\leq 24\text{ dBmV}$ , K  $\leq 30\text{ dBmV}$ , I  $\leq 36\text{ dBmV}$ , H  $\leq 42\text{ dBmV}$

## 2.2.7 Designing with radiated emissions in mind

To find application notes that provide guidance on designing your system to minimize interference from radiated emissions:

1. Go to [www.freescale.com](http://www.freescale.com).
2. Perform a keyword search for “EMC design.”

## 2.2.8 Capacitance attributes

Table 8. Capacitance attributes

Symbol	Description	Min.	Max.	Unit
$C_{IN\_A}$	Input capacitance: analog pins	—	7	pF
$C_{IN\_D}$	Input capacitance: digital pins	—	7	pF

## 2.3 Switching specifications

### 2.3.1 Device clock specifications

Table 9. Device clock specifications

Symbol	Description	Min.	Max.	Unit	Notes
High Speed run mode					
$f_{SYS}$	System and core clock	—	120	MHz	
$f_{BUS}$	Bus clock	—	60	MHz	
Normal run mode (and High Speed run mode unless otherwise specified above)					
$f_{SYS}$	System and core clock	—	80	MHz	
$f_{SYS\_USB}$	System and core clock when Full Speed USB in operation	20	—	MHz	
$f_{BUS}$	Bus clock	—	50	MHz	
FB_CLK	FlexBus clock	—	30	MHz	
$f_{FLASH}$	Flash clock	—	26.67	MHz	

Table continues on the next page...



**Table 9. Device clock specifications (continued)**

Symbol	Description	Min.	Max.	Unit	Notes
f <sub>LPTMR</sub>	LPTMR clock	—	25	MHz	
VLPR mode <sup>1</sup>					
f <sub>SYS</sub>	System and core clock	—	4	MHz	
f <sub>BUS</sub>	Bus clock	—	4	MHz	
FB_CLK	FlexBus clock	—	4	MHz	
f <sub>FLASH</sub>	Flash clock	—	1	MHz	
f <sub>ERCLK</sub>	External reference clock	—	16	MHz	
f <sub>LPTMR_pin</sub>	LPTMR clock	—	25	MHz	
f <sub>LPTMR_ERCLK</sub>	LPTMR external reference clock	—	16	MHz	
f <sub>I2S_MCLK</sub>	I2S master clock	—	12.5	MHz	
f <sub>I2S_BCLK</sub>	I2S bit clock	—	4	MHz	

1. The frequency limitations in VLPR mode here override any frequency specification listed in the timing specification for any other module.

## 2.3.2 General switching specifications

These general purpose specifications apply to all signals configured for GPIO, UART, and timers.

**Table 10. General switching specifications**

Symbol	Description	Min.	Max.	Unit	Notes
	GPIO pin interrupt pulse width (digital glitch filter disabled) — Synchronous path	1.5	—	Bus clock cycles	1, 2
	External RESET and NMI pin interrupt pulse width — Asynchronous path	100	—	ns	3
	GPIO pin interrupt pulse width (digital glitch filter disabled, passive filter disabled) — Asynchronous path	50	—	ns	4
	Mode select (EZP_CS) hold time after reset deassertion	2	—	Bus clock cycles	
	Port rise and fall time				5
	• Slew disabled	—			
	• 1.71 ≤ V <sub>DD</sub> ≤ 2.7V	—	10	ns	
	• 2.7 ≤ V <sub>DD</sub> ≤ 3.6V	—	5	ns	
	• Slew enabled	—			
	• 1.71 ≤ V <sub>DD</sub> ≤ 2.7V	—	30	ns	
	• 2.7 ≤ V <sub>DD</sub> ≤ 3.6V	—	16	ns	

## General

1. This is the minimum pulse width that is guaranteed to pass through the pin synchronization circuitry. Shorter pulses may or may not be recognized. In Stop, VLPS, LLS, and VLLSx modes, the synchronizer is bypassed so shorter pulses can be recognized in that case.
2. The greater of synchronous and asynchronous timing must be met.
3. These pins have a passive filter enabled on the inputs. This is the shortest pulse width that is guaranteed to be recognized.
4. These pins do not have a passive filter on the inputs. This is the shortest pulse width that is guaranteed to be recognized.
5. 25 pF load

## 2.4 Thermal specifications

### 2.4.1 Thermal operating requirements

Table 11. Thermal operating requirements

Symbol	Description	Min.	Max.	Unit
T <sub>J</sub>	Die junction temperature	-40	125	°C
T <sub>A</sub>	Ambient temperature	-40	105	°C

### 2.4.2 Thermal attributes

Board type	Symbol	Description	121 XFBGA	100 LQFP	64 LQFP	64 MAPBGA	Unit	Notes
Single-layer (1s)	R <sub>θJA</sub>	Thermal resistance, junction to ambient (natural convection)	44.4	61	67	TBD	°C/W	1
Four-layer (2s2p)	R <sub>θJA</sub>	Thermal resistance, junction to ambient (natural convection)	27.0	48	48	TBD	°C/W	2
Single-layer (1s)	R <sub>θJMA</sub>	Thermal resistance, junction to ambient (200 ft./min. air speed)	37.2	51	55	TBD	°C/W	3
Four-layer (2s2p)	R <sub>θJMA</sub>	Thermal resistance,	23.7	42	42	TBD	°C/W	3

Table continues on the next page...

Board type	Symbol	Description	121 XFBGA	100 LQFP	64 LQFP	64 MAPBGA	Unit	Notes
		junction to ambient (200 ft./min. air speed)						
—	$R_{\theta JB}$	Thermal resistance, junction to board	23.5	34	31	TBD	°C/W	4
—	$R_{\theta JC}$	Thermal resistance, junction to case	17.4	16	16	TBD	°C/W	5
—	$\Psi_{JT}$	Thermal characterization parameter, junction to package top outside center (natural convection)	0.2	3	3	TBD	°C/W	6

**NOTES:**

1. Determined according to JEDEC Standard JESD51-2, *Integrated Circuits Thermal Test Method Environmental Conditions—Natural Convection (Still Air)* with the single layer board horizontal. Board meets JESD51-9 specification.
2. Determined according to JEDEC Standard JESD51-2, *Integrated Circuits Thermal Test Method Environmental Conditions—Natural Convection (Still Air)*.
3. Determined according to JEDEC Standard JESD51-6, *Integrated Circuits Thermal Test Method Environmental Conditions—Forced Convection (Moving Air)* with the board horizontal.
4. Determined according to JEDEC Standard JESD51-8, *Integrated Circuit Thermal Test Method Environmental Conditions—Junction-to-Board*.
5. Thermal resistance between the die and the case top surface as measured by the cold plate method (MIL SPEC-883 Method 1012.1).
6. Thermal characterization parameter indicating the temperature difference between package top and the junction temperature per JEDEC JESD51-2.

### 3 Peripheral operating requirements and behaviors

### 3.1 Core modules

#### 3.1.1 SWD electricals

Table 12. SWD full voltage range electricals

Symbol	Description	Min.	Max.	Unit
	Operating voltage	1.71	3.6	V
S1	SWD_CLK frequency of operation • Serial wire debug	0	33	MHz
S2	SWD_CLK cycle period	1/S1	—	ns
S3	SWD_CLK clock pulse width • Serial wire debug	15	—	ns
S4	SWD_CLK rise and fall times	—	3	ns
S9	SWD_DIO input data setup time to SWD_CLK rise	8	—	ns
S10	SWD_DIO input data hold time after SWD_CLK rise	1.4	—	ns
S11	SWD_CLK high to SWD_DIO data valid	—	25	ns
S12	SWD_CLK high to SWD_DIO high-Z	5	—	ns

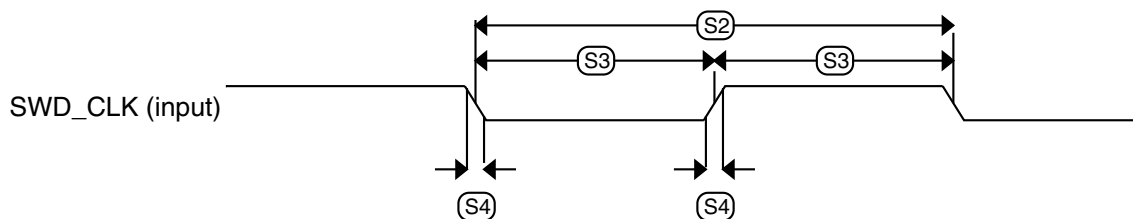

Figure 5. Serial wire clock input timing

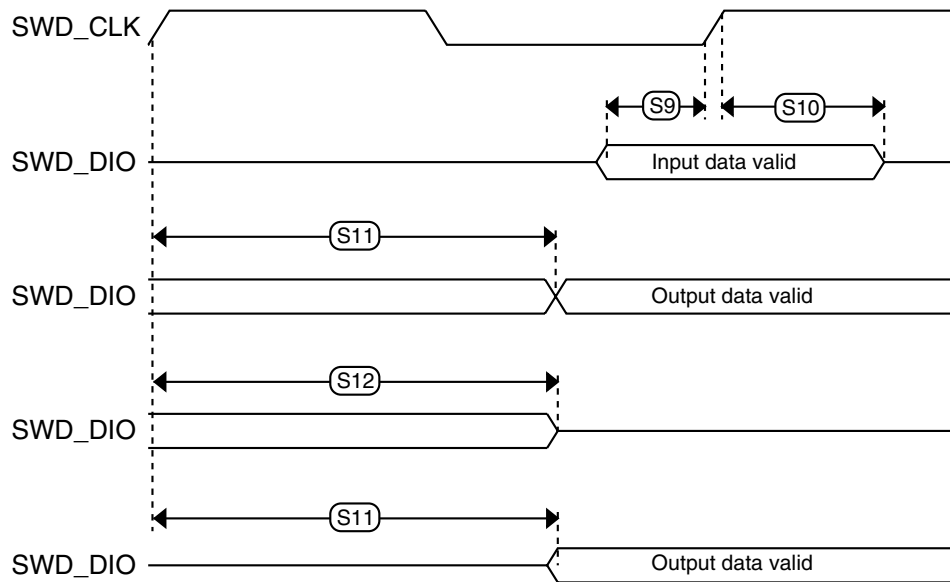

Figure 6. Serial wire data timing

### 3.1.2 JTAG electricals

Table 13. JTAG limited voltage range electricals

Symbol	Description	Min.	Max.	Unit
	Operating voltage	2.7	3.6	V
J1	TCLK frequency of operation			MHz
	• Boundary Scan	0	10	
	• JTAG and CJTAG	0	20	
J2	TCLK cycle period	1/J1	—	ns
J3	TCLK clock pulse width			
	• Boundary Scan	50	—	ns
	• JTAG and CJTAG	25	—	ns
J4	TCLK rise and fall times	—	3	ns
J5	Boundary scan input data setup time to TCLK rise	20	—	ns
J6	Boundary scan input data hold time after TCLK rise	1	—	ns
J7	TCLK low to boundary scan output data valid	—	25	ns
J8	TCLK low to boundary scan output high-Z	—	25	ns
J9	TMS, TDI input data setup time to TCLK rise	8	—	ns

Table continues on the next page...

**Table 13. JTAG limited voltage range electricals (continued)**

Symbol	Description	Min.	Max.	Unit
J10	TMS, TDI input data hold time after TCLK rise	1	—	ns
J11	TCLK low to TDO data valid	—	19	ns
J12	TCLK low to TDO high-Z	—	19	ns
J13	$\overline{\text{TRST}}$ assert time	100	—	ns
J14	$\overline{\text{TRST}}$ setup time (negation) to TCLK high	8	—	ns

**Table 14. JTAG full voltage range electricals**

Symbol	Description	Min.	Max.	Unit
	Operating voltage	1.71	3.6	V
J1	TCLK frequency of operation <ul style="list-style-type: none"> <li>• Boundary Scan</li> <li>• JTAG and CJTAG</li> </ul>	0 0	10 15	MHz
J2	TCLK cycle period	1/J1	—	ns
J3	TCLK clock pulse width <ul style="list-style-type: none"> <li>• Boundary Scan</li> <li>• JTAG and CJTAG</li> </ul>	50 33	— —	ns ns
J4	TCLK rise and fall times	—	3	ns
J5	Boundary scan input data setup time to TCLK rise	20	—	ns
J6	Boundary scan input data hold time after TCLK rise	1.4	—	ns
J7	TCLK low to boundary scan output data valid	—	27	ns
J8	TCLK low to boundary scan output high-Z	—	27	ns
J9	TMS, TDI input data setup time to TCLK rise	8	—	ns
J10	TMS, TDI input data hold time after TCLK rise	1.4	—	ns
J11	TCLK low to TDO data valid	—	26.2	ns
J12	TCLK low to TDO high-Z	—	26.2	ns
J13	$\overline{\text{TRST}}$ assert time	100	—	ns
J14	$\overline{\text{TRST}}$ setup time (negation) to TCLK high	8	—	ns

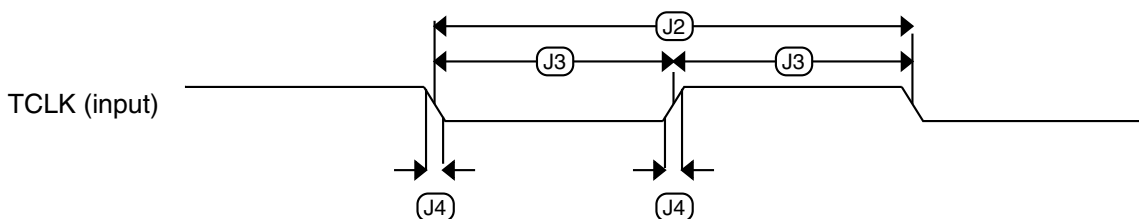

**Figure 7. Test clock input timing**

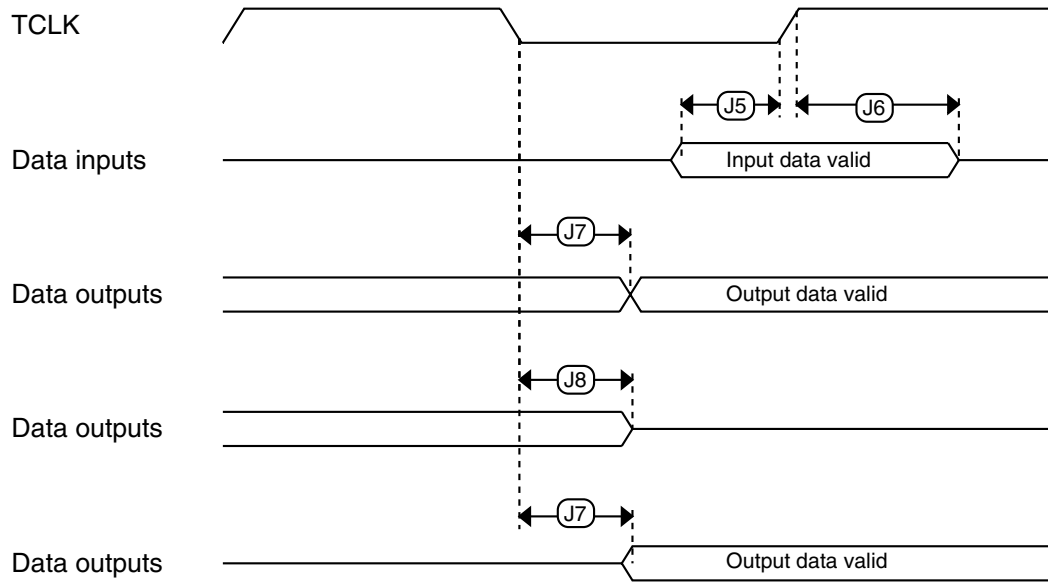

Figure 8. Boundary scan (JTAG) timing

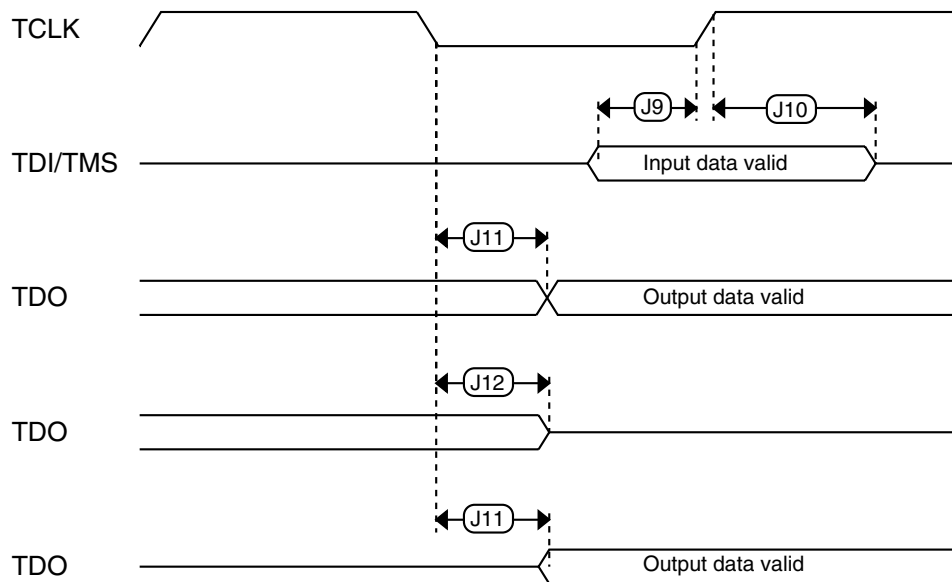

Figure 9. Test Access Port timing

## Peripheral operating requirements and behaviors

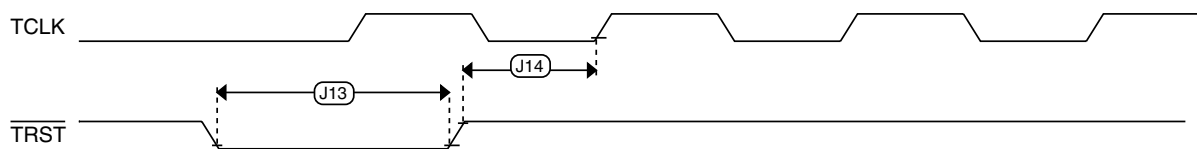

Figure 10.  $\overline{\text{TRST}}$  timing

## 3.2 System modules

There are no specifications necessary for the device's system modules.

## 3.3 Clock modules

### 3.3.1 MCG specifications

Table 15. MCG specifications

Symbol	Description	Min.	Typ.	Max.	Unit	Notes
$f_{\text{ints\_ft}}$	Internal reference frequency (slow clock) — factory trimmed at nominal VDD and 25 °C	—	32.768	—	kHz	
$\Delta f_{\text{ints\_t}}$	Total deviation of internal reference frequency (slow clock) over voltage and temperature	—	+0.5/-0.7	± 2	%	
$f_{\text{ints\_t}}$	Internal reference frequency (slow clock) — user trimmed	31.25	—	39.0625	kHz	
$\Delta f_{\text{dco\_res\_t}}$	Resolution of trimmed average DCO output frequency at fixed voltage and temperature — using SCTRIM and SCFTRIM	—	± 0.3	± 0.6	% $f_{\text{dco}}$	1
$\Delta f_{\text{dco\_t}}$	Total deviation of trimmed average DCO output frequency over voltage and temperature	—	+0.5/-0.7	± 2	% $f_{\text{dco}}$	1, 2
$\Delta f_{\text{dco\_t}}$	Total deviation of trimmed average DCO output frequency over fixed voltage and temperature range of 0–70°C	—	± 0.3	± 1.5	% $f_{\text{dco}}$	1
$f_{\text{intf\_ft}}$	Internal reference frequency (fast clock) — factory trimmed at nominal VDD and 25°C	—	4	—	MHz	
$\Delta f_{\text{intf\_ft}}$	Frequency deviation of internal reference clock (fast clock) over temperature and voltage — factory trimmed at nominal VDD and 25 °C	—	+1/-2	± 5	% $f_{\text{intf\_ft}}$	
$f_{\text{intf\_t}}$	Internal reference frequency (fast clock) — user trimmed at nominal VDD and 25 °C	3	—	5	MHz	

Table continues on the next page...



Table 15. MCG specifications (continued)

Symbol	Description	Min.	Typ.	Max.	Unit	Notes	
$f_{loc\_low}$	Loss of external clock minimum frequency — RANGE = 00	$(3/5) \times f_{ints\_t}$	—	—	kHz		
$f_{loc\_high}$	Loss of external clock minimum frequency — RANGE = 01, 10, or 11	$(16/5) \times f_{ints\_t}$	—	—	kHz		
FLL							
$f_{fill\_ref}$	FLL reference frequency range	31.25	—	39.0625	kHz		
$f_{dco}$	DCO output frequency range	Low range (DRS=00) $640 \times f_{fill\_ref}$	20	20.97	25	MHz	3, 4
		Mid range (DRS=01) $1280 \times f_{fill\_ref}$	40	41.94	50	MHz	
		Mid-high range (DRS=10) $1920 \times f_{fill\_ref}$	60	62.91	75	MHz	
		High range (DRS=11) $2560 \times f_{fill\_ref}$	80	83.89	100	MHz	
$f_{dco\_t\_DMX3}$ 2	DCO output frequency	Low range (DRS=00) $732 \times f_{fill\_ref}$	—	23.99	—	MHz	5, 6
		Mid range (DRS=01) $1464 \times f_{fill\_ref}$	—	47.97	—	MHz	
		Mid-high range (DRS=10) $2197 \times f_{fill\_ref}$	—	71.99	—	MHz	
		High range (DRS=11) $2929 \times f_{fill\_ref}$	—	95.98	—	MHz	
$J_{cyc\_fill}$	FLL period jitter • $f_{VCO} = 48$ MHz • $f_{VCO} = 98$ MHz	— —	— 180 150	— —	ps		
$t_{fill\_acquire}$	FLL target frequency acquisition time	—	—	1	ms	7	
PLL							
$f_{vco}$	VCO operating frequency	48.0	—	100	MHz		
$I_{pll}$	PLL operating current • PLL @ 96 MHz ( $f_{osc\_hi\_1} = 8$ MHz, $f_{pll\_ref} = 2$ MHz, VDIV multiplier = 48)	—	1060	—	$\mu$ A	8	
$I_{pll}$	PLL operating current • PLL @ 48 MHz ( $f_{osc\_hi\_1} = 8$ MHz, $f_{pll\_ref} = 2$ MHz, VDIV multiplier = 24)	—	600	—	$\mu$ A	8	
$f_{pll\_ref}$	PLL reference frequency range	2.0	—	4.0	MHz		
$J_{cyc\_pll}$	PLL period jitter (RMS) • $f_{vco} = 48$ MHz • $f_{vco} = 100$ MHz	—	120	—	ps	9	
		—	75	—	ps		
$J_{acc\_pll}$	PLL accumulated jitter over 1 $\mu$ s (RMS)					9	

Table continues on the next page...

**Table 15. MCG specifications (continued)**

Symbol	Description	Min.	Typ.	Max.	Unit	Notes
	<ul style="list-style-type: none"> <li><math>f_{VCO} = 48 \text{ MHz}</math></li> <li><math>f_{VCO} = 100 \text{ MHz}</math></li> </ul>	—	1350	—	ps	
		—	600	—	ps	
$D_{lock}$	Lock entry frequency tolerance	$\pm 1.49$	—	$\pm 2.98$	%	
$D_{unl}$	Lock exit frequency tolerance	$\pm 4.47$	—	$\pm 5.97$	%	
$t_{pll\_lock}$	Lock detector detection time	—	—	$150 \times 10^{-6} + 1075(1/f_{pll\_ref})$	s	10

1. This parameter is measured with the internal reference (slow clock) being used as a reference to the FLL (FEI clock mode).
2.  $2.0 \text{ V} \leq VDD \leq 3.6 \text{ V}$ .
3. These typical values listed are with the slow internal reference clock (FEI) using factory trim and DMX32=0.
4. The resulting system clock frequencies should not exceed their maximum specified values. The DCO frequency deviation ( $\Delta f_{dco\_t}$ ) over voltage and temperature should be considered.
5. These typical values listed are with the slow internal reference clock (FEI) using factory trim and DMX32=1.
6. The resulting clock frequency must not exceed the maximum specified clock frequency of the device.
7. This specification applies to any time the FLL reference source or reference divider is changed, trim value is changed, DMX32 bit is changed, DRS bits are changed, or changing from FLL disabled (BLPE, BLPI) to FLL enabled (FEI, FEE, FBE, FBI). If a crystal/resonator is being used as the reference, this specification assumes it is already running.
8. Excludes any oscillator currents that are also consuming power while PLL is in operation.
9. This specification was obtained using a Freescale developed PCB. PLL jitter is dependent on the noise characteristics of each PCB and results will vary.
10. This specification applies to any time the PLL VCO divider or reference divider is changed, or changing from PLL disabled (BLPE, BLPI) to PLL enabled (PBE, PEE). If a crystal/resonator is being used as the reference, this specification assumes it is already running.

### 3.3.2 IRC48M specifications

**Table 16. IRC48M specifications**

Symbol	Description	Min.	Typ.	Max.	Unit	Notes
$V_{DD}$	Supply voltage	1.71	—	3.6	V	
$I_{DD48M}$	Supply current	—	400	500	$\mu\text{A}$	
$f_{irc48m}$	Internal reference frequency	—	48	—	MHz	
$\Delta f_{irc48m\_ol\_lv}$	Open loop total deviation of IRC48M frequency at low voltage ( $VDD=1.71\text{V}-1.89\text{V}$ ) over temperature <ul style="list-style-type: none"> <li>Regulator disable (USB_CLK_RECOVER_IRC_EN[REG_EN]=0)</li> <li>Regulator enable (USB_CLK_RECOVER_IRC_EN[REG_EN]=1)</li> </ul>	—	$\pm 0.5$	$\pm 1.0$	$\%f_{irc48m}$	
$\Delta f_{irc48m\_ol\_hv}$	Open loop total deviation of IRC48M frequency at high voltage ( $VDD=1.89\text{V}-3.6\text{V}$ ) over temperature <ul style="list-style-type: none"> <li>Regulator enable (USB_CLK_RECOVER_IRC_EN[REG_EN]=1)</li> </ul>	—	$\pm 0.5$	$\pm 1.0$	$\%f_{irc48m}$	
$\Delta f_{irc48m\_cl}$	Closed loop total deviation of IRC48M frequency over voltage and temperature	—	—	$\pm 0.1$	$\%f_{host}$	1

Table continues on the next page...

**Table 16. IRC48M specifications (continued)**

Symbol	Description	Min.	Typ.	Max.	Unit	Notes
J <sub>cyc_irc48m</sub>	Period Jitter (RMS)	—	35	150	ps	
t <sub>irc48mst</sub>	Startup time	—	2	3	μs	2

1. Closed loop operation of the IRC48M is only feasible for USB device operation; it is not usable for USB host operation. It is enabled by configuring for USB Device, selecting IRC48M as USB clock source, and enabling the clock recover function (USB\_CLK\_RECOVER\_IRC\_CTRL[CLOCK\_RECOVER\_EN]=1, USB\_CLK\_RECOVER\_IRC\_EN[IRC\_EN]=1).
2. IRC48M startup time is defined as the time between clock enablement and clock availability for system use. Enable the clock by one of the following settings:
  - USB\_CLK\_RECOVER\_IRC\_EN[IRC\_EN]=1, or
  - MCG operating in an external clocking mode and MCG\_C7[OSCSSEL]=10, or
  - SIM\_SOPT2[PLLFLLSEL]=11

### 3.3.3 Oscillator electrical specifications

#### 3.3.3.1 Oscillator DC electrical specifications

**Table 17. Oscillator DC electrical specifications**

Symbol	Description	Min.	Typ.	Max.	Unit	Notes
V <sub>DD</sub>	Supply voltage	1.71	—	3.6	V	
I <sub>DDOSC</sub>	Supply current — low-power mode (HGO=0) <ul style="list-style-type: none"> <li>• 32 kHz</li> <li>• 4 MHz</li> <li>• 8 MHz (RANGE=01)</li> <li>• 16 MHz</li> <li>• 24 MHz</li> <li>• 32 MHz</li> </ul>	—	500	—	nA	1
I <sub>DDOSC</sub>	Supply current — high-gain mode (HGO=1) <ul style="list-style-type: none"> <li>• 32 kHz</li> <li>• 4 MHz</li> <li>• 8 MHz (RANGE=01)</li> <li>• 16 MHz</li> <li>• 24 MHz</li> <li>• 32 MHz</li> </ul>	—	25	—	μA	1
C <sub>x</sub>	EXTAL load capacitance	—	—	—		2, 3
C <sub>y</sub>	XTAL load capacitance	—	—	—		2, 3
R <sub>F</sub>	Feedback resistor — low-frequency, low-power mode (HGO=0)	—	—	—	MΩ	2, 4

Table continues on the next page...

**Table 17. Oscillator DC electrical specifications (continued)**

Symbol	Description	Min.	Typ.	Max.	Unit	Notes
	Feedback resistor — low-frequency, high-gain mode (HGO=1)	—	10	—	MΩ	
	Feedback resistor — high-frequency, low-power mode (HGO=0)	—	—	—	MΩ	
	Feedback resistor — high-frequency, high-gain mode (HGO=1)	—	1	—	MΩ	
R <sub>S</sub>	Series resistor — low-frequency, low-power mode (HGO=0)	—	—	—	kΩ	
	Series resistor — low-frequency, high-gain mode (HGO=1)	—	200	—	kΩ	
	Series resistor — high-frequency, low-power mode (HGO=0)	—	—	—	kΩ	
	Series resistor — high-frequency, high-gain mode (HGO=1)	—	0	—	kΩ	
V <sub>pp</sub> <sup>5</sup>	Peak-to-peak amplitude of oscillation (oscillator mode) — low-frequency, low-power mode (HGO=0)	—	0.6	—	V	
	Peak-to-peak amplitude of oscillation (oscillator mode) — low-frequency, high-gain mode (HGO=1)	—	V <sub>DD</sub>	—	V	
	Peak-to-peak amplitude of oscillation (oscillator mode) — high-frequency, low-power mode (HGO=0)	—	0.6	—	V	
	Peak-to-peak amplitude of oscillation (oscillator mode) — high-frequency, high-gain mode (HGO=1)	—	V <sub>DD</sub>	—	V	

1. V<sub>DD</sub>=3.3 V, Temperature =25 °C
2. See crystal or resonator manufacturer's recommendation
3. C<sub>x</sub> and C<sub>y</sub> can be provided by using either integrated capacitors or external components.
4. When low-power mode is selected, R<sub>F</sub> is integrated and must not be attached externally.
5. The EXTAL and XTAL pins should only be connected to required oscillator components and must not be connected to any other device.

### 3.3.3.2 Oscillator frequency specifications

**Table 18. Oscillator frequency specifications**

Symbol	Description	Min.	Typ.	Max.	Unit	Notes
f <sub>osc_lo</sub>	Oscillator crystal or resonator frequency — low-frequency mode (MCG_C2[RANGE]=00)	32	—	40	kHz	
f <sub>osc_hi_1</sub>	Oscillator crystal or resonator frequency — high-frequency mode (low range) (MCG_C2[RANGE]=01)	3	—	8	MHz	

Table continues on the next page...

**Table 18. Oscillator frequency specifications (continued)**

Symbol	Description	Min.	Typ.	Max.	Unit	Notes
$f_{osc\_hi\_2}$	Oscillator crystal or resonator frequency — high frequency mode (high range) (MCG_C2[RANGE]=1x)	8	—	32	MHz	
$f_{ec\_extal}$	Input clock frequency (external clock mode)	—	—	50	MHz	1, 2
$t_{dc\_extal}$	Input clock duty cycle (external clock mode)	40	50	60	%	
$t_{cst}$	Crystal startup time — 32 kHz low-frequency, low-power mode (HGO=0)	—	750	—	ms	3, 4
	Crystal startup time — 32 kHz low-frequency, high-gain mode (HGO=1)	—	250	—	ms	
	Crystal startup time — 8 MHz high-frequency (MCG_C2[RANGE]=01), low-power mode (HGO=0)	—	0.6	—	ms	
	Crystal startup time — 8 MHz high-frequency (MCG_C2[RANGE]=01), high-gain mode (HGO=1)	—	1	—	ms	

1. Other frequency limits may apply when external clock is being used as a reference for the FLL or PLL.
2. When transitioning from FEI or FBI to FBE mode, restrict the frequency of the input clock so that, when it is divided by FRDIV, it remains within the limits of the DCO input clock frequency.
3. Proper PC board layout procedures must be followed to achieve specifications.
4. Crystal startup time is defined as the time between the oscillator being enabled and the OSCINIT bit in the MCG\_S register being set.

### 3.3.4 32 kHz oscillator electrical characteristics

#### 3.3.4.1 32 kHz oscillator DC electrical specifications

**Table 19. 32kHz oscillator DC electrical specifications**

Symbol	Description	Min.	Typ.	Max.	Unit
$V_{BAT}$	Supply voltage	1.71	—	3.6	V
$R_F$	Internal feedback resistor	—	100	—	M $\Omega$
$C_{para}$	Parasitical capacitance of EXTAL32 and XTAL32	—	5	7	pF
$V_{pp}^1$	Peak-to-peak amplitude of oscillation	—	0.6	—	V

1. When a crystal is being used with the 32 kHz oscillator, the EXTAL32 and XTAL32 pins should only be connected to required oscillator components and must not be connected to any other devices.

### 3.3.4.2 32 kHz oscillator frequency specifications

Table 20. 32 kHz oscillator frequency specifications

Symbol	Description	Min.	Typ.	Max.	Unit	Notes
$f_{osc\_lo}$	Oscillator crystal	—	32.768	—	kHz	
$t_{start}$	Crystal start-up time	—	1000	—	ms	1
$f_{ec\_extal32}$	Externally provided input clock frequency	—	32.768	—	kHz	2
$V_{ec\_extal32}$	Externally provided input clock amplitude	700	—	$V_{BAT}$	mV	2, 3

1. Proper PC board layout procedures must be followed to achieve specifications.
2. This specification is for an externally supplied clock driven to EXTAL32 and does not apply to any other clock input. The oscillator remains enabled and XTAL32 must be left unconnected.
3. The parameter specified is a peak-to-peak value and  $V_{IH}$  and  $V_{IL}$  specifications do not apply. The voltage of the applied clock must be within the range of  $V_{SS}$  to  $V_{BAT}$ .

## 3.4 Memories and memory interfaces

### 3.4.1 Flash electrical specifications

This section describes the electrical characteristics of the flash memory module.

#### 3.4.1.1 Flash timing specifications — program and erase

The following specifications represent the amount of time the internal charge pumps are active and do not include command overhead.

Table 21. NVM program/erase timing specifications

Symbol	Description	Min.	Typ.	Max.	Unit	Notes
$t_{hvp4}$	Longword Program high-voltage time	—	7.5	18	$\mu$ s	
$t_{hversscr}$	Sector Erase high-voltage time	—	13	113	ms	1
$t_{hversall}$	Erase All high-voltage time	—	52	452	ms	1

1. Maximum time based on expectations at cycling end-of-life.

#### 3.4.1.2 Flash timing specifications — commands

Table 22. Flash command timing specifications

Symbol	Description	Min.	Typ.	Max.	Unit	Notes
$t_{rd1sec2k}$	Read 1s Section execution time (flash sector)	—	—	60	$\mu$ s	1
$t_{pgmchk}$	Program Check execution time	—	—	45	$\mu$ s	1

Table continues on the next page...

**Table 22. Flash command timing specifications (continued)**

Symbol	Description	Min.	Typ.	Max.	Unit	Notes
$t_{rdsrc}$	Read Resource execution time	—	—	30	$\mu$ s	1
$t_{pgm4}$	Program Longword execution time	—	65	145	$\mu$ s	
$t_{ersscr}$	Erase Flash Sector execution time	—	14	114	ms	2
$t_{rd1all}$	Read 1s All Blocks execution time	—	—	1.8	ms	
$t_{rdonce}$	Read Once execution time	—	—	30	$\mu$ s	1
$t_{pgmonce}$	Program Once execution time	—	100	—	$\mu$ s	
$t_{ersall}$	Erase All Blocks execution time	—	500	3000	ms	2
$t_{vfykey}$	Verify Backdoor Access Key execution time	—	—	30	$\mu$ s	1

1. Assumes 25 MHz flash clock frequency.
2. Maximum times for erase parameters based on expectations at cycling end-of-life.

### 3.4.1.3 Flash high voltage current behaviors

**Table 23. Flash high voltage current behaviors**

Symbol	Description	Min.	Typ.	Max.	Unit
$I_{DD\_PGM}$	Average current adder during high voltage flash programming operation	—	2.5	6.0	mA
$I_{DD\_ERS}$	Average current adder during high voltage flash erase operation	—	1.5	4.0	mA

### 3.4.1.4 Reliability specifications

**Table 24. NVM reliability specifications**

Symbol	Description	Min.	Typ. <sup>1</sup>	Max.	Unit	Notes
Program Flash						
$t_{nvmretp10k}$	Data retention after up to 10 K cycles	5	50	—	years	
$t_{nvmretp1k}$	Data retention after up to 1 K cycles	20	100	—	years	
$n_{nvmcycp}$	Cycling endurance	10 K	50 K	—	cycles	2

1. Typical data retention values are based on measured response accelerated at high temperature and derated to a constant 25 °C use profile. Engineering Bulletin EB618 does not apply to this technology. Typical endurance defined in Engineering Bulletin EB619.
2. Cycling endurance represents number of program/erase cycles at  $-40\text{ °C} \leq T_j \leq 125\text{ °C}$ .

### 3.4.2 EzPort switching specifications

Table 25. EzPort switching specifications

Num	Description	Min.	Max.	Unit
	Operating voltage	1.71	3.6	V
EP1	EZP_CK frequency of operation (all commands except READ)	—	$f_{SYS}/2$	MHz
EP1a	EZP_CK frequency of operation (READ command)	—	$f_{SYS}/8$	MHz
EP2	$\overline{EZP\_CS}$ negation to next $\overline{EZP\_CS}$ assertion	$2 \times t_{EZP\_CK}$	—	ns
EP3	$\overline{EZP\_CS}$ input valid to EZP_CK high (setup)	5	—	ns
EP4	EZP_CK high to $\overline{EZP\_CS}$ input invalid (hold)	5	—	ns
EP5	EZP_D input valid to EZP_CK high (setup)	2	—	ns
EP6	EZP_CK high to EZP_D input invalid (hold)	5	—	ns
EP7	EZP_CK low to EZP_Q output valid	—	25	ns
EP8	EZP_CK low to EZP_Q output invalid (hold)	0	—	ns
EP9	$\overline{EZP\_CS}$ negation to EZP_Q tri-state	—	12	ns

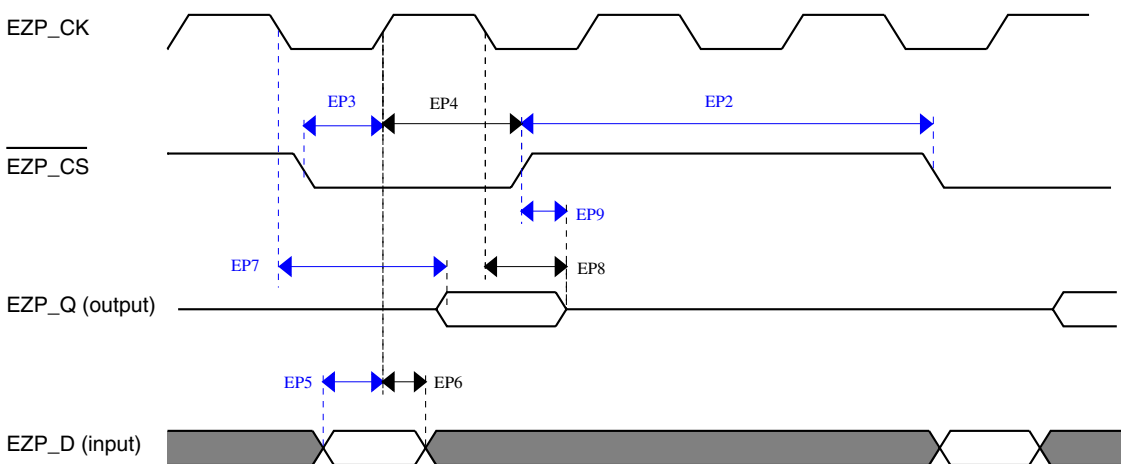

Figure 11. EzPort Timing Diagram

### 3.4.3 Flexbus switching specifications

All processor bus timings are synchronous; input setup/hold and output delay are given in respect to the rising edge of a reference clock, FB\_CLK. The FB\_CLK frequency may be the same as the internal system bus frequency or an integer divider of that frequency.



The following timing numbers indicate when data is latched or driven onto the external bus, relative to the Flexbus output clock (FB\_CLK). All other timing relationships can be derived from these values.

**Table 26. Flexbus limited voltage range switching specifications**

Num	Description	Min.	Max.	Unit	Notes
	Operating voltage	2.7	3.6	V	
	Frequency of operation	—	30	MHz	
FB1	Clock period	33.3	—	ns	
FB2	Address, data, and control output valid	—	15	ns	
FB3	Address, data, and control output hold	0.5	—	ns	1
FB4	Data and $\overline{\text{FB\_TA}}$ input setup	14.5	—	ns	
FB5	Data and $\overline{\text{FB\_TA}}$ input hold	0.5	—	ns	2

1. Specification is valid for all FB\_AD[31:0],  $\overline{\text{FB\_BE/BWE}}$ ,  $\overline{\text{FB\_CS}}$ , FB\_OE, FB\_R/W,  $\overline{\text{FB\_TBST}}$ , FB\_TSIZE[1:0], FB\_ALE, and FB\_TS.
2. Specification is valid for all FB\_AD[31:0] and  $\overline{\text{FB\_TA}}$ .

**Table 27. Flexbus full voltage range switching specifications**

Num	Description	Min.	Max.	Unit	Notes
	Operating voltage	1.71	3.6	V	
	Frequency of operation	—	30	MHz	
FB1	Clock period	33.3	—	ns	
FB2	Address, data, and control output valid	—	21.5	ns	
FB3	Address, data, and control output hold	-1.0	—	ns	1
FB4	Data and $\overline{\text{FB\_TA}}$ input setup	20.0	—	ns	
FB5	Data and $\overline{\text{FB\_TA}}$ input hold	0.5	—	ns	2

1. Specification is valid for all FB\_AD[31:0],  $\overline{\text{FB\_BE/BWE}}$ ,  $\overline{\text{FB\_CS}}$ , FB\_OE, FB\_R/W,  $\overline{\text{FB\_TBST}}$ , FB\_TSIZE[1:0], FB\_ALE, and FB\_TS.
2. Specification is valid for all FB\_AD[31:0] and  $\overline{\text{FB\_TA}}$ .

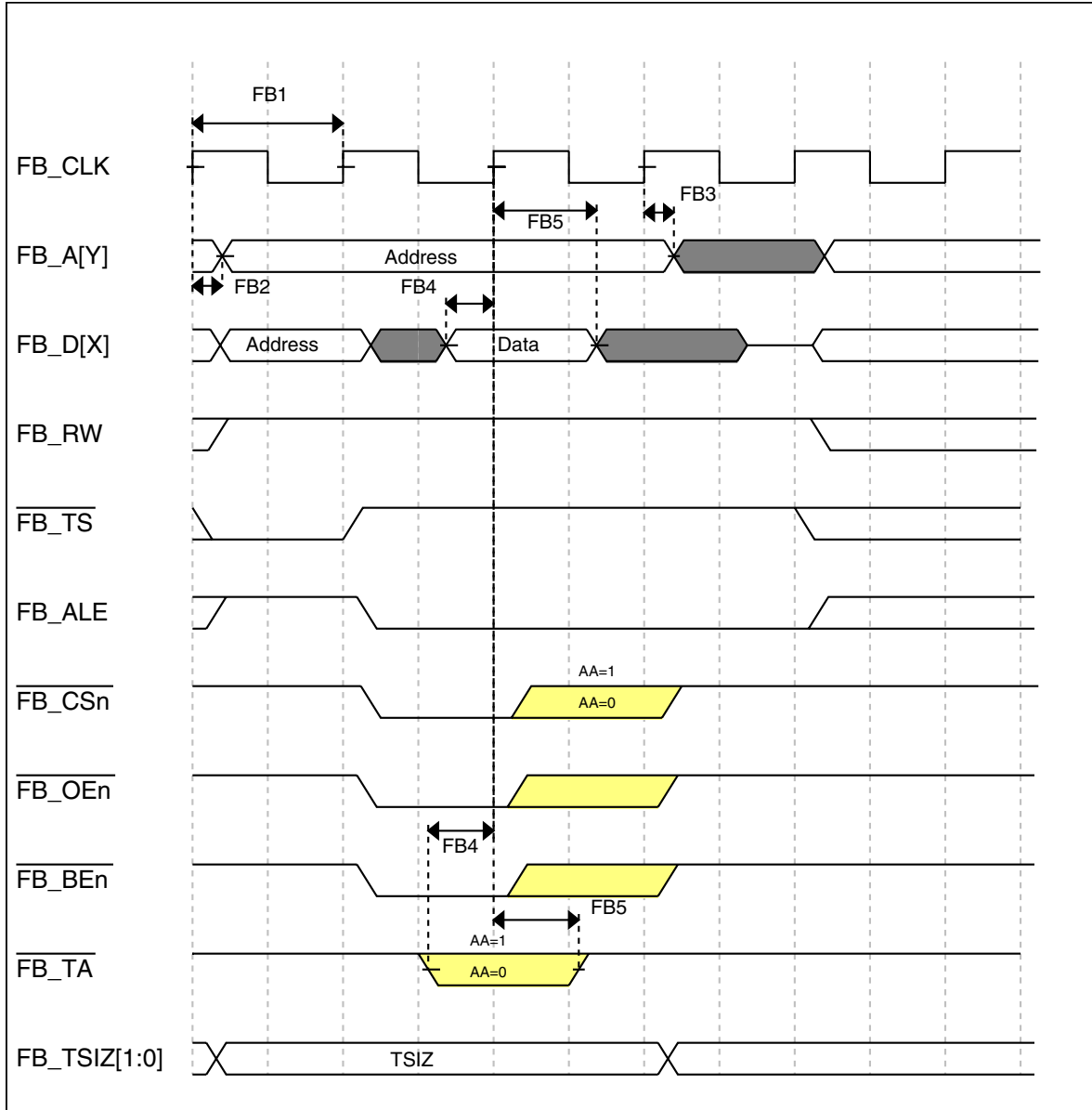

Figure 12. FlexBus read timing diagram

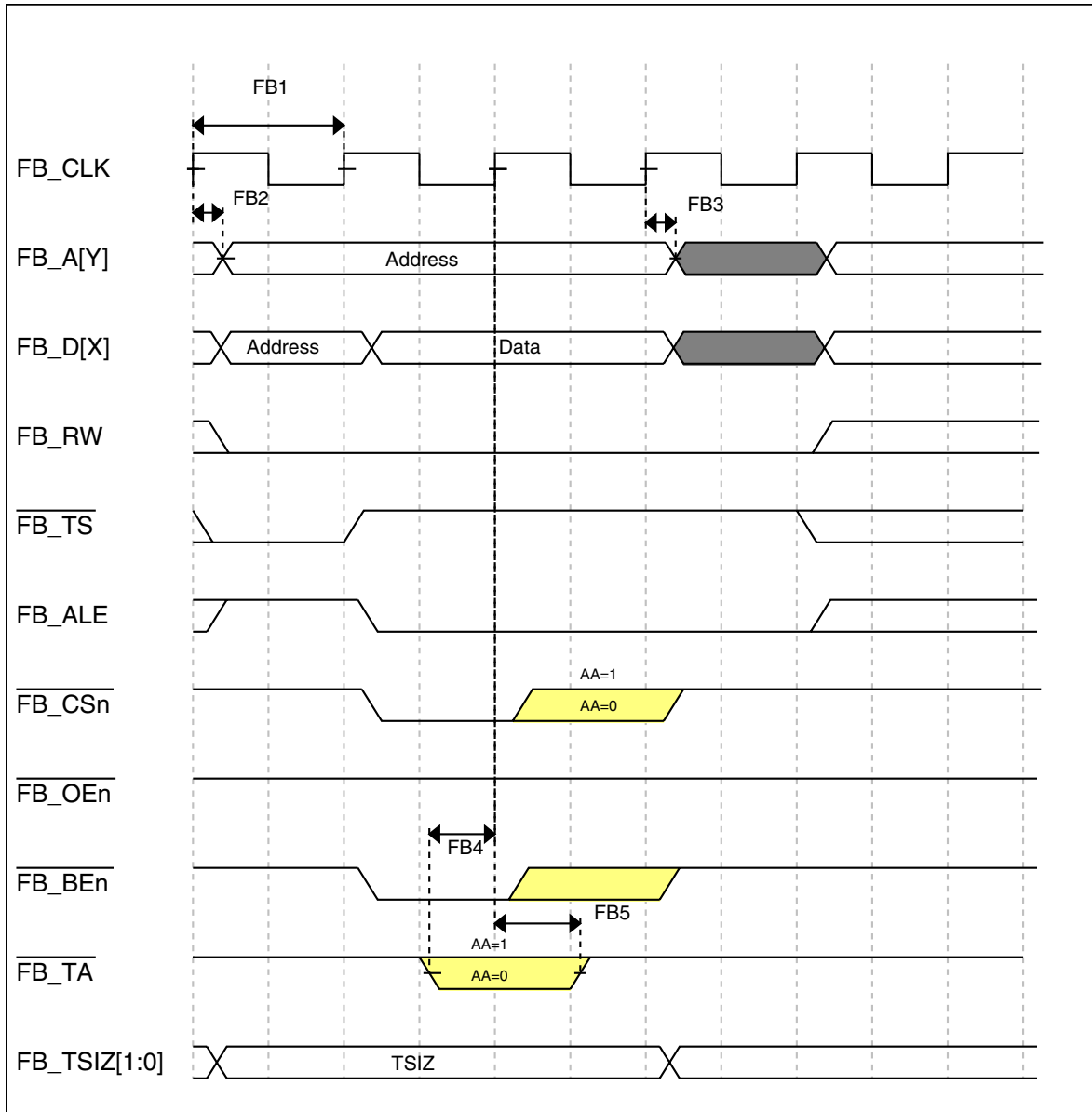

Figure 13. FlexBus write timing diagram

### 3.5 Security and integrity modules

There are no specifications necessary for the device's security and integrity modules.

### 3.6 Analog

### 3.6.1 ADC electrical specifications

The 16-bit accuracy specifications listed in [Table 28](#) and [Table 29](#) are achievable on the differential pins ADCx\_DPx, ADCx\_DMx.

All other ADC channels meet the 13-bit differential/12-bit single-ended accuracy specifications.

#### 3.6.1.1 16-bit ADC operating conditions

**Table 28. 16-bit ADC operating conditions**

Symbol	Description	Conditions	Min.	Typ. <sup>1</sup>	Max.	Unit	Notes
V <sub>DDA</sub>	Supply voltage	Absolute	1.71	—	3.6	V	
ΔV <sub>DDA</sub>	Supply voltage	Delta to V <sub>DD</sub> (V <sub>DD</sub> – V <sub>DDA</sub> )	-100	0	+100	mV	2
ΔV <sub>SSA</sub>	Ground voltage	Delta to V <sub>SS</sub> (V <sub>SS</sub> – V <sub>SSA</sub> )	-100	0	+100	mV	2
V <sub>REFH</sub>	ADC reference voltage high		1.13	V <sub>DDA</sub>	V <sub>DDA</sub>	V	
V <sub>REFL</sub>	ADC reference voltage low		V <sub>SSA</sub>	V <sub>SSA</sub>	V <sub>SSA</sub>	V	
V <sub>ADIN</sub>	Input voltage	<ul style="list-style-type: none"> <li>16-bit differential mode</li> <li>All other modes</li> </ul>	V <sub>REFL</sub> V <sub>REFL</sub>	— —	31/32 * V <sub>REFH</sub> V <sub>REFH</sub>	V	
C <sub>ADIN</sub>	Input capacitance	<ul style="list-style-type: none"> <li>16-bit mode</li> <li>8-bit / 10-bit / 12-bit modes</li> </ul>	— —	8 4	10 5	pF	
R <sub>ADIN</sub>	Input series resistance		—	2	5	kΩ	
R <sub>AS</sub>	Analog source resistance (external)	13-bit / 12-bit modes f <sub>ADCK</sub> < 4 MHz	—	—	5	kΩ	3
f <sub>ADCK</sub>	ADC conversion clock frequency	≤ 13-bit mode	1.0	—	24.0	MHz	4
f <sub>ADCK</sub>	ADC conversion clock frequency	16-bit mode	2.0	—	12.0	MHz	4
C <sub>rate</sub>	ADC conversion rate	≤ 13-bit modes No ADC hardware averaging Continuous conversions enabled, subsequent conversion time	20	—	1200	Ksps	5
C <sub>rate</sub>	ADC conversion rate	16-bit mode No ADC hardware averaging	37	—	461	Ksps	5

**Table 28. 16-bit ADC operating conditions**

Symbol	Description	Conditions	Min.	Typ. <sup>1</sup>	Max.	Unit	Notes
		Continuous conversions enabled, subsequent conversion time					

1. Typical values assume  $V_{DDA} = 3.0\text{ V}$ ,  $\text{Temp} = 25\text{ }^{\circ}\text{C}$ ,  $f_{\text{ADCK}} = 1.0\text{ MHz}$ , unless otherwise stated. Typical values are for reference only, and are not tested in production.
2. DC potential difference.
3. This resistance is external to MCU. To achieve the best results, the analog source resistance must be kept as low as possible. The results in this data sheet were derived from a system that had  $< 8\ \Omega$  analog source resistance. The  $R_{\text{AS}}/C_{\text{AS}}$  time constant should be kept to  $< 1\text{ ns}$ .
4. To use the maximum ADC conversion clock frequency,  $\text{CFG2}[\text{ADHSC}]$  must be set and  $\text{CFG1}[\text{ADLPC}]$  must be clear.
5. For guidelines and examples of conversion rate calculation, download the [ADC calculator tool](#).

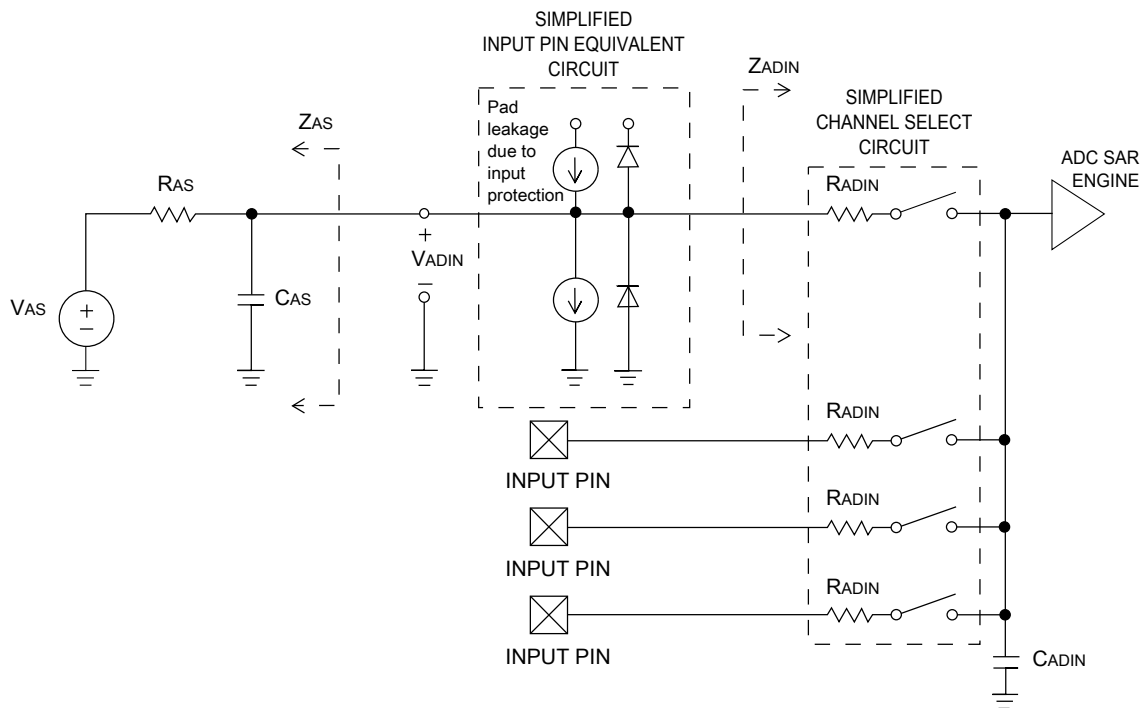
**Figure 14. ADC input impedance equivalency diagram**

### 3.6.1.2 16-bit ADC electrical characteristics

**Table 29. 16-bit ADC characteristics ( $V_{\text{REFH}} = V_{\text{DDA}}$ ,  $V_{\text{REFL}} = V_{\text{SSA}}$ )**

Symbol	Description	Conditions <sup>1</sup>	Min.	Typ. <sup>2</sup>	Max.	Unit	Notes
$I_{\text{DDA\_ADC}}$	Supply current		0.215	—	1.7	mA	3

Table continues on the next page...

**Table 29. 16-bit ADC characteristics ( $V_{REFH} = V_{DDA}$ ,  $V_{REFL} = V_{SSA}$ ) (continued)**

Symbol	Description	Conditions <sup>1</sup>	Min.	Typ. <sup>2</sup>	Max.	Unit	Notes
$f_{ADACK}$	ADC asynchronous clock source	• ADLPC = 1, ADHSC = 0	1.2	2.4	3.9	MHz	$t_{ADACK} = 1/f_{ADACK}$
		• ADLPC = 1, ADHSC = 1	2.4	4.0	6.1	MHz	
		• ADLPC = 0, ADHSC = 0	3.0	5.2	7.3	MHz	
		• ADLPC = 0, ADHSC = 1	4.4	6.2	9.5	MHz	
	Sample Time	See Reference Manual chapter for sample times					
TUE	Total unadjusted error	• 12-bit modes • <12-bit modes	— —	$\pm 4$ $\pm 1.4$	$\pm 6.8$ $\pm 2.1$	LSB <sup>4</sup>	5
DNL	Differential non-linearity	• 12-bit modes • <12-bit modes	— —	$\pm 0.7$ $\pm 0.2$	-1.1 to +1.9 -0.3 to 0.5	LSB <sup>4</sup>	5
INL	Integral non-linearity	• 12-bit modes • <12-bit modes	— —	$\pm 1.0$ $\pm 0.5$	-2.7 to +1.9 -0.7 to +0.5	LSB <sup>4</sup>	5
$E_{FS}$	Full-scale error	• 12-bit modes • <12-bit modes	— —	-4 -1.4	-5.4 -1.8	LSB <sup>4</sup>	$V_{ADIN} = V_{DDA}$ <sup>5</sup>
$E_Q$	Quantization error	• 16-bit modes • $\leq 13$ -bit modes	— —	-1 to 0 —	— $\pm 0.5$	LSB <sup>4</sup>	
ENOB	Effective number of bits	16-bit differential mode	12.8	14.5	—	bits	6
		• Avg = 32	11.9	13.8	—	bits	
		• Avg = 4	12.2	13.9	—	bits	
		16-bit single-ended mode	11.4	13.1	—	bits	
		• Avg = 32 • Avg = 4					
SINAD	Signal-to-noise plus distortion	See ENOB	$6.02 \times \text{ENOB} + 1.76$			dB	
THD	Total harmonic distortion	16-bit differential mode	—	-94	—	dB	7
		• Avg = 32	—	-85	—	dB	
		16-bit single-ended mode					
		• Avg = 32					
SFDR	Spurious free dynamic range	16-bit differential mode	82	95	—	dB	7
		• Avg = 32	78	90	—	dB	

Table continues on the next page...

**Table 29. 16-bit ADC characteristics ( $V_{REFH} = V_{DDA}$ ,  $V_{REFL} = V_{SSA}$ ) (continued)**

Symbol	Description	Conditions <sup>1</sup>	Min.	Typ. <sup>2</sup>	Max.	Unit	Notes
		16-bit single-ended mode • Avg = 32					
$E_{IL}$	Input leakage error		$I_{in} \times R_{AS}$			mV	$I_{in}$ = leakage current (refer to the MCU's voltage and current operating ratings)
	Temp sensor slope	Across the full temperature range of the device	1.55	1.62	1.69	mV/°C	8
$V_{TEMP25}$	Temp sensor voltage	25 °C	706	716	726	mV	8

- All accuracy numbers assume the ADC is calibrated with  $V_{REFH} = V_{DDA}$
- Typical values assume  $V_{DDA} = 3.0$  V, Temp = 25 °C,  $f_{ADCK} = 2.0$  MHz unless otherwise stated. Typical values are for reference only and are not tested in production.
- The ADC supply current depends on the ADC conversion clock speed, conversion rate and ADC\_CFG1[ADLPC] (low power). For lowest power operation, ADC\_CFG1[ADLPC] must be set, the ADC\_CFG2[ADHSC] bit must be clear with 1 MHz ADC conversion clock speed.
- 1 LSB =  $(V_{REFH} - V_{REFL})/2^N$
- ADC conversion clock < 16 MHz, Max hardware averaging (AVGE = %1, AVGS = %11)
- Input data is 100 Hz sine wave. ADC conversion clock < 12 MHz.
- Input data is 1 kHz sine wave. ADC conversion clock < 12 MHz.
- ADC conversion clock < 3 MHz

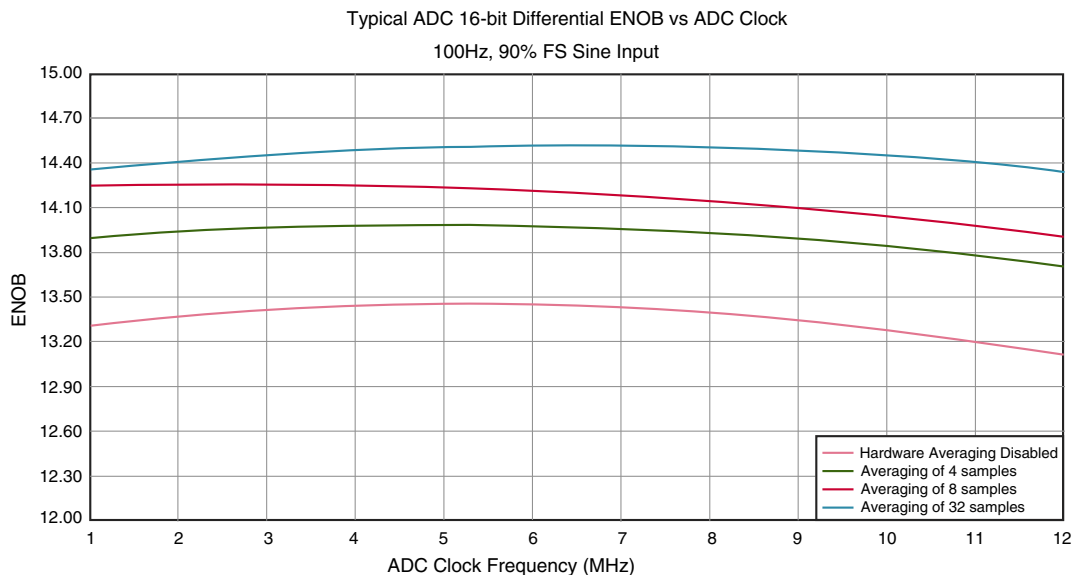
**Figure 15. Typical ENOB vs. ADC\_CLK for 16-bit differential mode**

## Peripheral operating requirements and behaviors

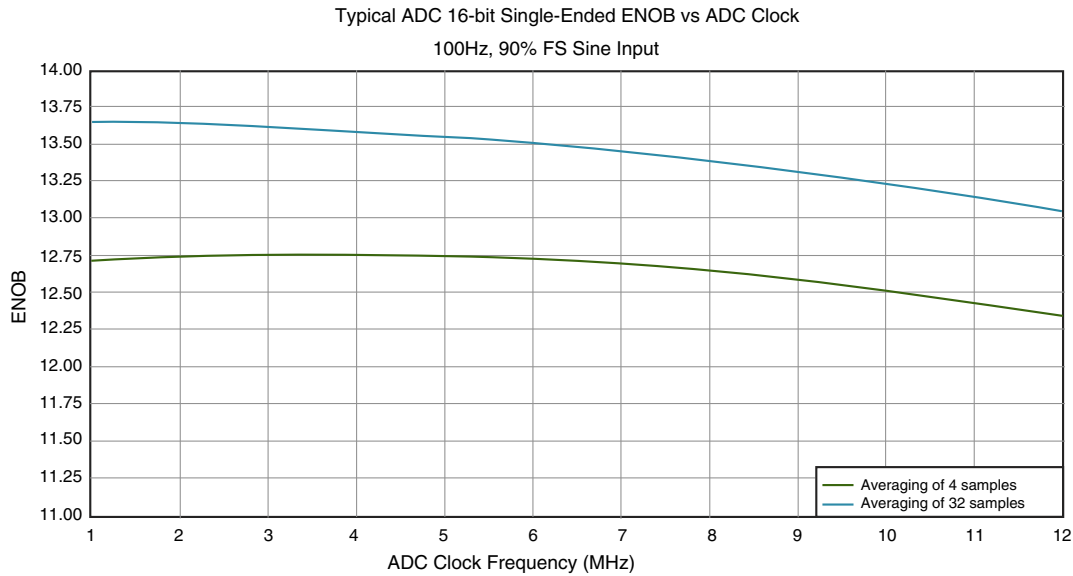

**Figure 16. Typical ENOB vs. ADC\_CLK for 16-bit single-ended mode**

### 3.6.2 CMP and 6-bit DAC electrical specifications

**Table 30. Comparator and 6-bit DAC electrical specifications**

Symbol	Description	Min.	Typ.	Max.	Unit
$V_{DD}$	Supply voltage	1.71	—	3.6	V
$I_{DDHS}$	Supply current, High-speed mode (EN=1, PMODE=1)	—	—	200	$\mu$ A
$I_{DDL S}$	Supply current, low-speed mode (EN=1, PMODE=0)	—	—	20	$\mu$ A
$V_{AIN}$	Analog input voltage	$V_{SS} - 0.3$	—	$V_{DD}$	V
$V_{AIO}$	Analog input offset voltage	—	—	20	mV
$V_H$	Analog comparator hysteresis <sup>1</sup> <ul style="list-style-type: none"> <li>• CR0[HYSTCTR] = 00</li> <li>• CR0[HYSTCTR] = 01</li> <li>• CR0[HYSTCTR] = 10</li> <li>• CR0[HYSTCTR] = 11</li> </ul>	—	5 10 20 30	—	mV
$V_{CMPOh}$	Output high	$V_{DD} - 0.5$	—	—	V
$V_{CMPOl}$	Output low	—	—	0.5	V
$t_{DHS}$	Propagation delay, high-speed mode (EN=1, PMODE=1)	20	50	200	ns
$t_{DLS}$	Propagation delay, low-speed mode (EN=1, PMODE=0)	80	250	600	ns
	Analog comparator initialization delay <sup>2</sup>	—	—	40	$\mu$ s
$I_{DAC6b}$	6-bit DAC current adder (enabled)	—	7	—	$\mu$ A

Table continues on the next page...



**Table 30. Comparator and 6-bit DAC electrical specifications (continued)**

Symbol	Description	Min.	Typ.	Max.	Unit
INL	6-bit DAC integral non-linearity	-0.5	—	0.5	LSB <sup>3</sup>
DNL	6-bit DAC differential non-linearity	-0.3	—	0.3	LSB

1. Typical hysteresis is measured with input voltage range limited to 0.6 to  $V_{DD}-0.6$  V.
2. Comparator initialization delay is defined as the time between software writes to change control inputs (Writes to CMP\_DACCR[DACEN], CMP\_DACCR[VRSEL], CMP\_DACCR[VOSEL], CMP\_MUXCR[PSEL], and CMP\_MUXCR[MSEL]) and the comparator output settling to a stable level.
3. 1 LSB =  $V_{reference}/64$

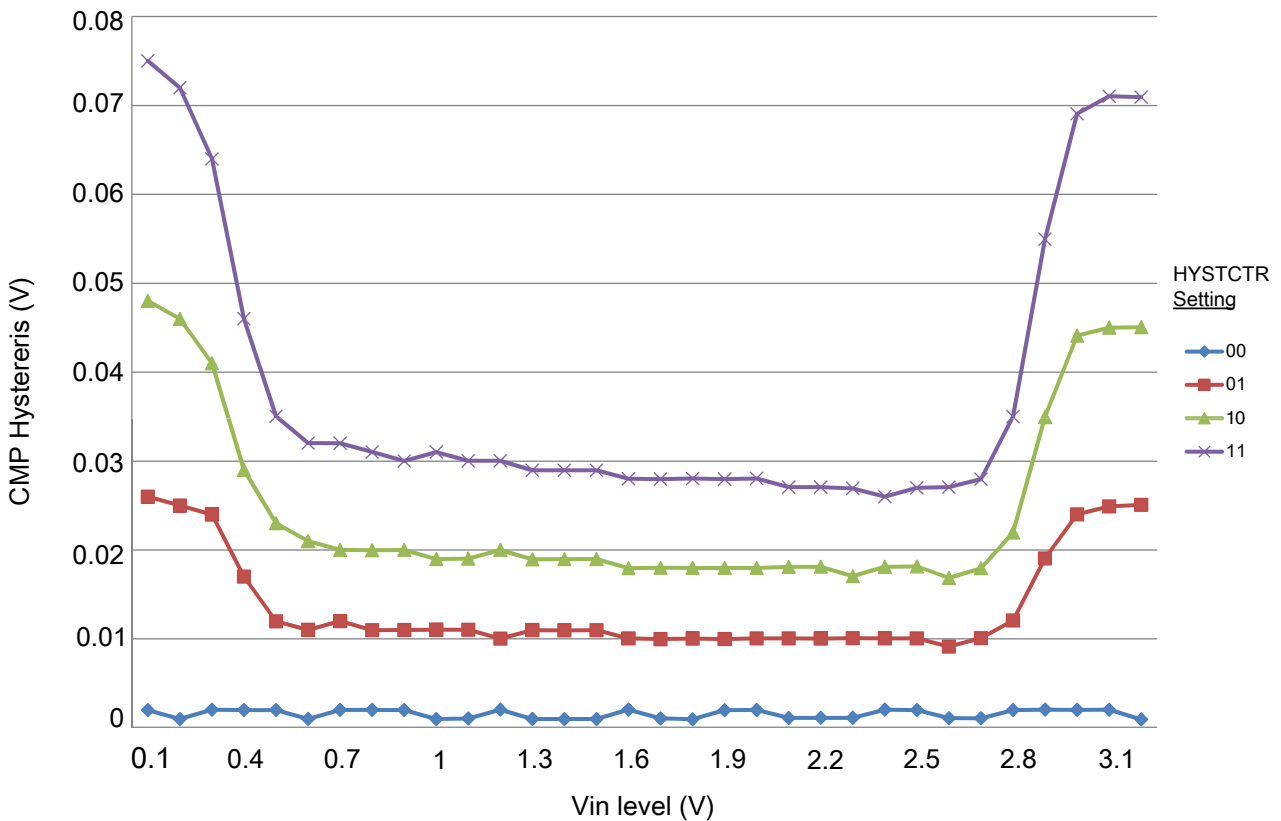
**Figure 17. Typical hysteresis vs. Vin level (VDD = 3.3 V, PMODE = 0)**

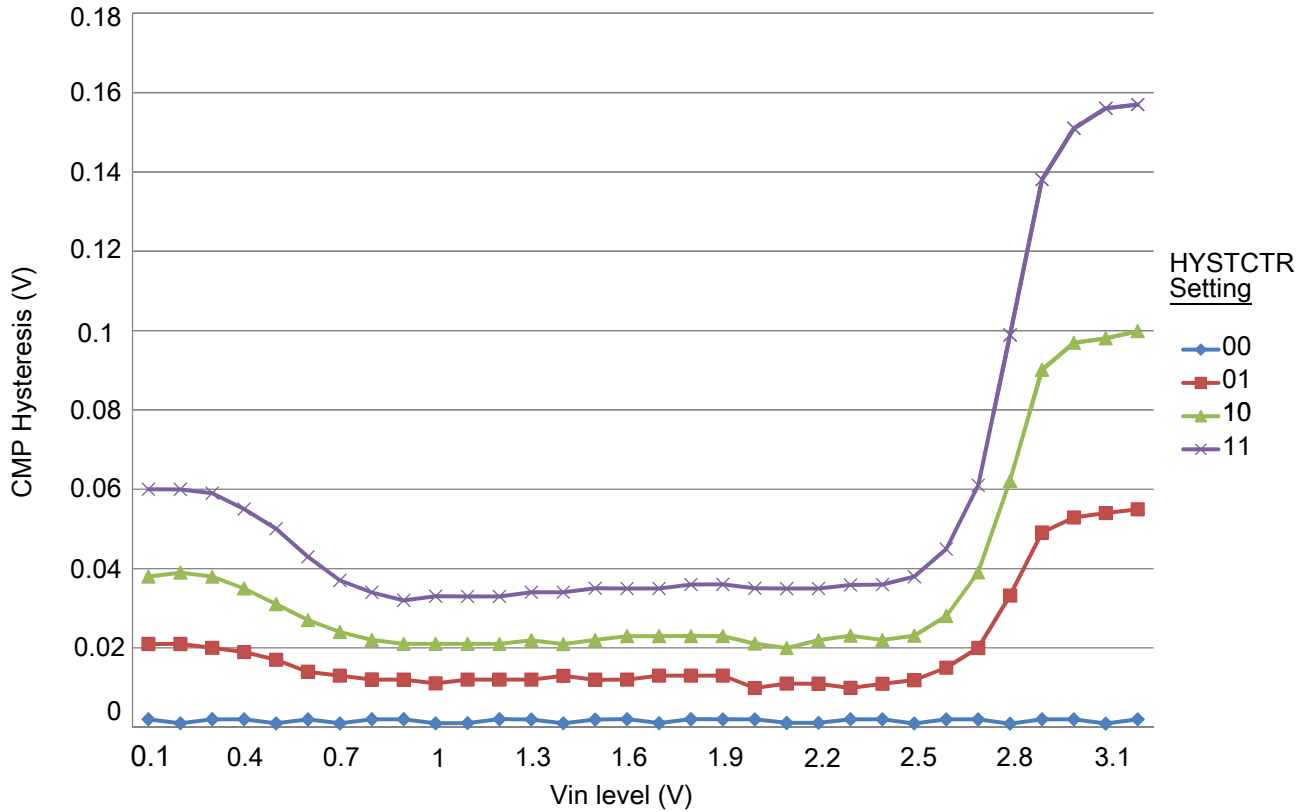

Figure 18. Typical hysteresis vs. Vin level (VDD = 3.3 V, PMODE = 1)

### 3.6.3 12-bit DAC electrical characteristics

#### 3.6.3.1 12-bit DAC operating requirements

Table 31. 12-bit DAC operating requirements

Symbol	Description	Min.	Max.	Unit	Notes
$V_{DDA}$	Supply voltage	1.71	3.6	V	
$V_{DACR}$	Reference voltage	1.13	3.6	V	1
$C_L$	Output load capacitance	—	100	pF	2
$I_L$	Output load current	—	1	mA	

1. The DAC reference can be selected to be  $V_{DDA}$  or  $V_{REFH}$ .
2. A small load capacitance (47 pF) can improve the bandwidth performance of the DAC.

### 3.6.3.2 12-bit DAC operating behaviors

Table 32. 12-bit DAC operating behaviors

Symbol	Description	Min.	Typ.	Max.	Unit	Notes
$I_{DDA\_DACLP}$	Supply current — low-power mode	—	—	330	$\mu\text{A}$	
$I_{DDA\_DACHP}$	Supply current — high-speed mode	—	—	1200	$\mu\text{A}$	
$t_{DACLP}$	Full-scale settling time (0x080 to 0xF7F) — low-power mode	—	100	200	$\mu\text{s}$	1
$t_{DACHP}$	Full-scale settling time (0x080 to 0xF7F) — high-power mode	—	15	30	$\mu\text{s}$	1
$t_{CCDACLP}$	Code-to-code settling time (0xBF8 to 0xC08) — low-power mode and high-speed mode	—	0.7	1	$\mu\text{s}$	1
$V_{dacoutl}$	DAC output voltage range low — high-speed mode, no load, DAC set to 0x000	—	—	100	mV	
$V_{dacouth}$	DAC output voltage range high — high-speed mode, no load, DAC set to 0xFFFF	$V_{DACR} - 100$	—	$V_{DACR}$	mV	
INL	Integral non-linearity error — high speed mode	—	—	$\pm 8$	LSB	2
DNL	Differential non-linearity error — $V_{DACR} > 2\text{ V}$	—	—	$\pm 1$	LSB	3
DNL	Differential non-linearity error — $V_{DACR} = V_{REF\_OUT}$	—	—	$\pm 1$	LSB	4
$V_{OFFSET}$	Offset error	—	$\pm 0.4$	$\pm 0.8$	%FSR	5
$E_G$	Gain error	—	$\pm 0.1$	$\pm 0.6$	%FSR	5
PSRR	Power supply rejection ratio, $V_{DDA} \geq 2.4\text{ V}$	60	—	90	dB	
$T_{CO}$	Temperature coefficient offset voltage	—	3.7	—	$\mu\text{V}/\text{C}$	6
$T_{GE}$	Temperature coefficient gain error	—	0.000421	—	%FSR/C	
$R_{op}$	Output resistance (load = 3 k $\Omega$ )	—	—	250	$\Omega$	
SR	Slew rate -80h → F7Fh → 80h <ul style="list-style-type: none"> <li>High power (<math>SP_{HP}</math>)</li> <li>Low power (<math>SP_{LP}</math>)</li> </ul>	1.2 0.05	1.7 0.12	— —	$\text{V}/\mu\text{s}$	
BW	3dB bandwidth <ul style="list-style-type: none"> <li>High power (<math>SP_{HP}</math>)</li> <li>Low power (<math>SP_{LP}</math>)</li> </ul>	550 40	— —	— —	kHz	

- Settling within  $\pm 1$  LSB
- The INL is measured for 0 + 100 mV to  $V_{DACR} - 100$  mV
- The DNL is measured for 0 + 100 mV to  $V_{DACR} - 100$  mV
- The DNL is measured for 0 + 100 mV to  $V_{DACR} - 100$  mV with  $V_{DDA} > 2.4\text{ V}$
- Calculated by a best fit curve from  $V_{SS} + 100$  mV to  $V_{DACR} - 100$  mV
- $V_{DDA} = 3.0\text{ V}$ , reference select set for  $V_{DDA}$  ( $DACx\_CO:DACRFS = 1$ ), high power mode ( $DACx\_CO:LPEN = 0$ ), DAC set to 0x800, temperature range is across the full range of the device

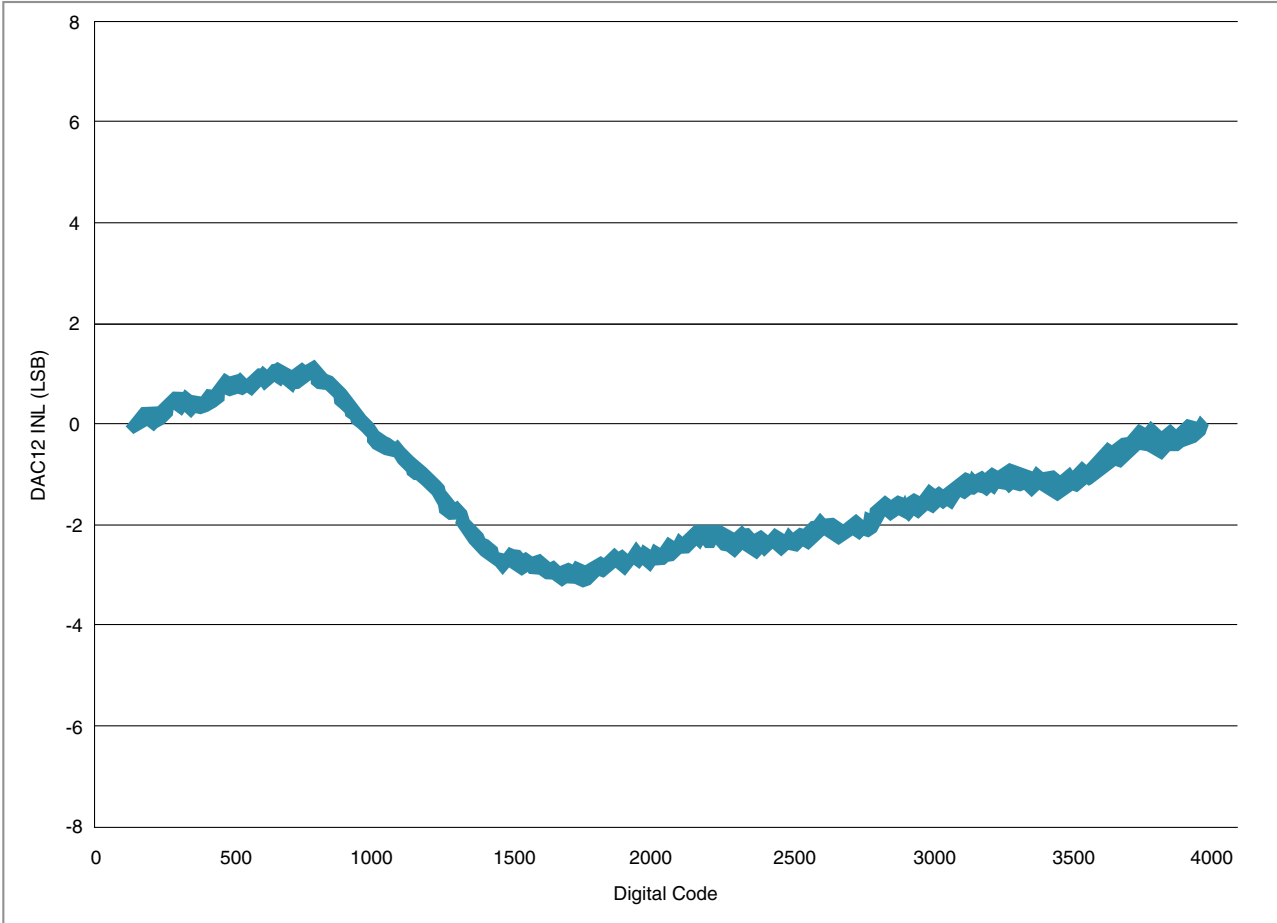

Figure 19. Typical INL error vs. digital code

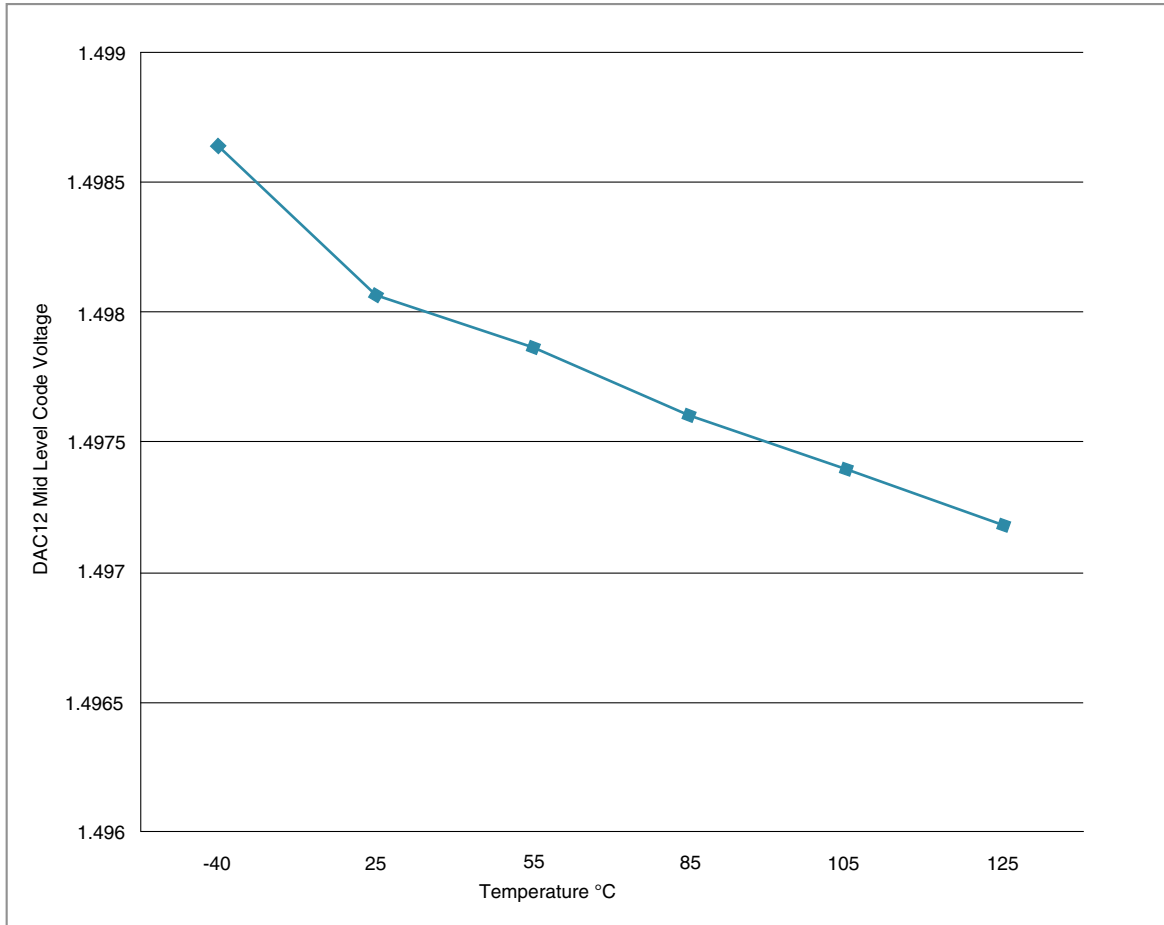

Figure 20. Offset at half scale vs. temperature

### 3.6.4 Voltage reference electrical specifications

Table 33. VREF full-range operating requirements

Symbol	Description	Min.	Max.	Unit	Notes
$V_{DDA}$	Supply voltage	1.71	3.6	V	
$T_A$	Temperature	Operating temperature range of the device		°C	
$C_L$	Output load capacitance	100		nF	1, 2

1.  $C_L$  must be connected to VREF\_OUT if the VREF\_OUT functionality is being used for either an internal or external reference.
2. The load capacitance should not exceed +/-25% of the nominal specified  $C_L$  value over the operating temperature range of the device.

**Table 34. VREF full-range operating behaviors**

Symbol	Description	Min.	Typ.	Max.	Unit	Notes
$V_{out}$	Voltage reference output with factory trim at nominal $V_{DDA}$ and temperature=25°C	1.1920	1.1950	1.1980	V	1
$V_{out}$	Voltage reference output with user trim at nominal $V_{DDA}$ and temperature=25°C	1.1945	1.1950	1.1955	V	1
$V_{step}$	Voltage reference trim step	—	0.5	—	mV	1
$V_{tdrift}$	Temperature drift ( $V_{max} - V_{min}$ across the full temperature range)	—	—	15	mV	1
$I_{bg}$	Bandgap only current	—	—	80	$\mu$ A	
$I_{lp}$	Low-power buffer current	—	—	360	$\mu$ A	1
$I_{hp}$	High-power buffer current	—	—	1	mA	1
$\Delta V_{LOAD}$	Load regulation • current = $\pm 1.0$ mA	—	200	—	$\mu$ V	1, 2
$T_{stup}$	Buffer startup time	—	—	100	$\mu$ s	
$T_{chop\_osc\_st\ up}$	Internal bandgap start-up delay with chop oscillator enabled	—	—	35	ms	
$V_{vdrift}$	Voltage drift ( $V_{max} - V_{min}$ across the full voltage range)	—	2	—	mV	1

1. See the chip's Reference Manual for the appropriate settings of the VREF Status and Control register.
2. Load regulation voltage is the difference between the VREF\_OUT voltage with no load vs. voltage with defined load

**Table 35. VREF limited-range operating requirements**

Symbol	Description	Min.	Max.	Unit	Notes
$T_A$	Temperature	0	70	°C	

**Table 36. VREF limited-range operating behaviors**

Symbol	Description	Min.	Max.	Unit	Notes
$V_{tdrift}$	Temperature drift ( $V_{max} - V_{min}$ across the limited temperature range)	—	10	mV	

## 3.7 Timers

See [General switching specifications](#).

## 3.8 Communication interfaces

### 3.8.1 USB electrical specifications

The USB electricals for the USB On-the-Go module conform to the standards documented by the Universal Serial Bus Implementers Forum. For the most up-to-date standards, visit [usb.org](http://usb.org).

#### NOTE

The MCGFLLCLK and IRC48M do not meet the USB jitter specifications for certification for Host mode operation.

### 3.8.2 USB VREG electrical specifications

**Table 37. USB VREG electrical specifications**

Symbol	Description	Min.	Typ. <sup>1</sup>	Max.	Unit	Notes
VREGIN	Input supply voltage	2.7	—	5.5	V	
I <sub>DDon</sub>	Quiescent current — Run mode, load current equal zero, input supply (VREGIN) > 3.6 V	—	125	186	μA	
I <sub>DDstby</sub>	Quiescent current — Standby mode, load current equal zero	—	1.1	10	μA	
I <sub>DDoff</sub>	Quiescent current — Shutdown mode <ul style="list-style-type: none"> <li>• VREGIN = 5.0 V and temperature=25 °C</li> <li>• Across operating voltage and temperature</li> </ul>	—	650	—	nA	
		—	—	4	μA	
I <sub>LOADrun</sub>	Maximum load current — Run mode	—	—	120	mA	
I <sub>LOADstby</sub>	Maximum load current — Standby mode	—	—	1	mA	
V <sub>Reg33out</sub>	Regulator output voltage — Input supply (VREGIN) > 3.6 V <ul style="list-style-type: none"> <li>• Run mode</li> <li>• Standby mode</li> </ul>	3	3.3	3.6	V	
		2.1	2.8	3.6	V	
V <sub>Reg33out</sub>	Regulator output voltage — Input supply (VREGIN) < 3.6 V, pass-through mode	2.1	—	3.6	V	2
C <sub>OUT</sub>	External output capacitor	1.76	2.2	8.16	μF	
ESR	External output capacitor equivalent series resistance	1	—	100	mΩ	
I <sub>LIM</sub>	Short circuit current	—	290	—	mA	

1. Typical values assume VREGIN = 5.0 V, Temp = 25 °C unless otherwise stated.
2. Operating in pass-through mode: regulator output voltage equal to the input voltage minus a drop proportional to I<sub>Load</sub>.

### 3.8.3 DSPI switching specifications (limited voltage range)

The Deserial Serial Peripheral Interface (DSPI) provides a synchronous serial bus with master and slave operations. Many of the transfer attributes are programmable. The tables below provide DSPI timing characteristics for classic SPI timing modes. Refer to the SPI chapter of the Reference Manual for information on the modified transfer formats used for communicating with slower peripheral devices.

**Table 38. Master mode DSPI timing (limited voltage range)**

Num	Description	Min.	Max.	Unit	Notes
	Operating voltage	2.7	3.6	V	
	Frequency of operation	—	30	MHz	
DS1	DSPI_SCK output cycle time	$2 \times t_{BUS}$	—	ns	
DS2	DSPI_SCK output high/low time	$(t_{SCK}/2) - 2$	$(t_{SCK}/2) + 2$	ns	
DS3	DSPI_PCSn valid to DSPI_SCK delay	$(t_{BUS} \times 2) - 2$	—	ns	1
DS4	DSPI_SCK to DSPI_PCSn invalid delay	$(t_{BUS} \times 2) - 2$	—	ns	2
DS5	DSPI_SCK to DSPI_SOUT valid	—	8.5	ns	
DS6	DSPI_SCK to DSPI_SOUT invalid	-2	—	ns	
DS7	DSPI_SIN to DSPI_SCK input setup	16.2	—	ns	
DS8	DSPI_SCK to DSPI_SIN input hold	0	—	ns	

1. The delay is programmable in SPIx\_CTARn[PSSCK] and SPIx\_CTARn[CSSCK].
2. The delay is programmable in SPIx\_CTARn[PASC] and SPIx\_CTARn[ASC].

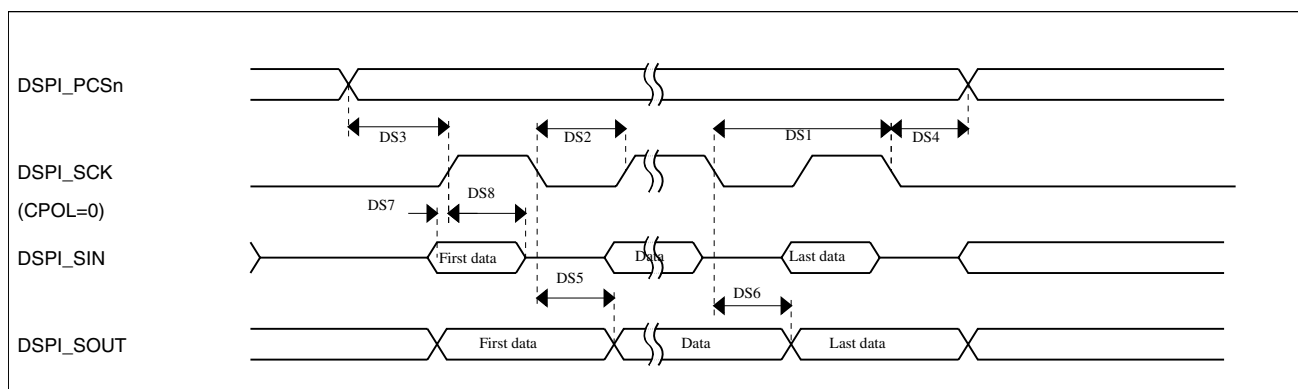

**Figure 21. DSPI classic SPI timing — master mode**

**Table 39. Slave mode DSPI timing (limited voltage range)**

Num	Description	Min.	Max.	Unit
	Operating voltage	2.7	3.6	V
	Frequency of operation	—	15	MHz

Table continues on the next page...



**Table 39. Slave mode DSPI timing (limited voltage range) (continued)**

Num	Description	Min.	Max.	Unit
DS9	DSPI_SCK input cycle time	$4 \times t_{\text{BUS}}$	—	ns
DS10	DSPI_SCK input high/low time	$(t_{\text{SCK}/2}) - 2$	$(t_{\text{SCK}/2}) + 2$	ns
DS11	DSPI_SCK to DSPI_SOUT valid	—	21.4	ns
DS12	DSPI_SCK to DSPI_SOUT invalid	0	—	ns
DS13	DSPI_SIN to DSPI_SCK input setup	2.6	—	ns
DS14	DSPI_SCK to DSPI_SIN input hold	7	—	ns
DS15	DSPI_SS active to DSPI_SOUT driven	—	17	ns </td
DS16	$\overline{\text{DSPI\_SS}}$ inactive to DSPI_SOUT not driven	—	17	ns

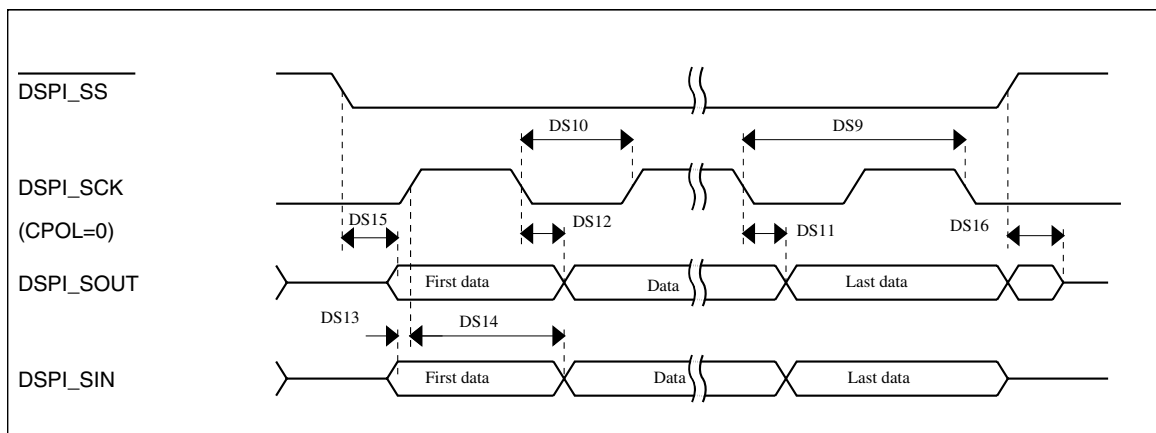
**Figure 22. DSPI classic SPI timing — slave mode**

### 3.8.4 DSPI switching specifications (full voltage range)

The Deserial Serial Peripheral Interface (DSPI) provides a synchronous serial bus with master and slave operations. Many of the transfer attributes are programmable. The tables below provides DSPI timing characteristics for classic SPI timing modes. Refer to the SPI chapter of the Reference Manual for information on the modified transfer formats used for communicating with slower peripheral devices.

**Table 40. Master mode DSPI timing (full voltage range)**

Num	Description	Min.	Max.	Unit	Notes
	Operating voltage	1.71	3.6	V	1
	Frequency of operation	—	15	MHz	
DS1	DSPI_SCK output cycle time	$4 \times t_{\text{BUS}}$	—	ns	
DS2	DSPI_SCK output high/low time	$(t_{\text{SCK}/2}) - 4$	$(t_{\text{SCK}/2}) + 4$	ns	

Table continues on the next page...

**Table 40. Master mode DSPI timing (full voltage range) (continued)**

Num	Description	Min.	Max.	Unit	Notes
DS3	DSPI_PCSn valid to DSPI_SCK delay	$(t_{BUS} \times 2) - 4$	—	ns	2
DS4	DSPI_SCK to DSPI_PCSn invalid delay	$(t_{BUS} \times 2) - 4$	—	ns	3
DS5	DSPI_SCK to DSPI_SOUT valid	—	10	ns	
DS6	DSPI_SCK to DSPI_SOUT invalid	-4.5	—	ns	
DS7	DSPI_SIN to DSPI_SCK input setup	24.6	—	ns	
DS8	DSPI_SCK to DSPI_SIN input hold	0	—	ns	

1. The DSPI module can operate across the entire operating voltage for the processor, but to run across the full voltage range the maximum frequency of operation is reduced.
2. The delay is programmable in SPIx\_CTARn[PSSCK] and SPIx\_CTARn[CSSCK].
3. The delay is programmable in SPIx\_CTARn[PASC] and SPIx\_CTARn[ASC].

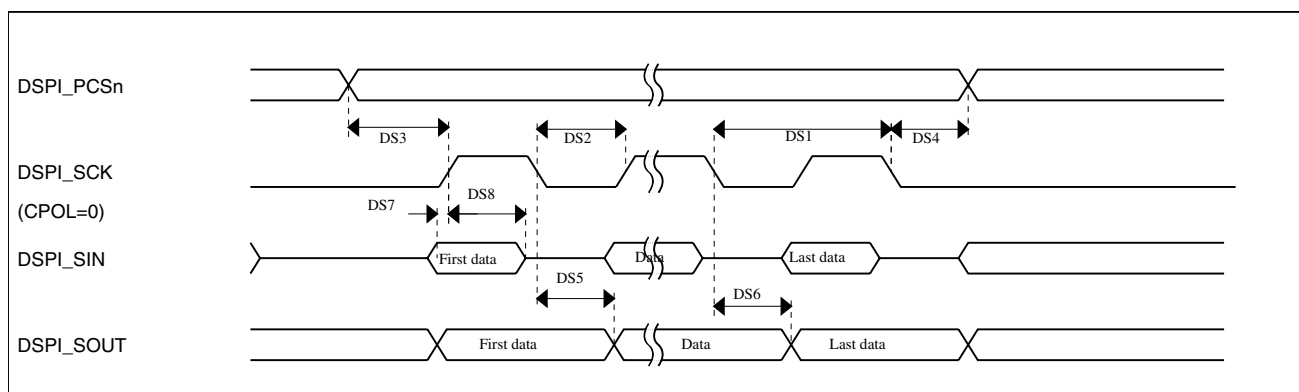

**Figure 23. DSPI classic SPI timing — master mode**

**Table 41. Slave mode DSPI timing (full voltage range)**

Num	Description	Min.	Max.	Unit
	Operating voltage	1.71	3.6	V
	Frequency of operation	—	7.5	MHz
DS9	DSPI_SCK input cycle time	$8 \times t_{BUS}$	—	ns
DS10	DSPI_SCK input high/low time	$(t_{SCK}/2) - 4$	$(t_{SCK}/2) + 4$	ns
DS11	DSPI_SCK to DSPI_SOUT valid	—	29.5	ns
DS12	DSPI_SCK to DSPI_SOUT invalid	0	—	ns
DS13	DSPI_SIN to DSPI_SCK input setup	3.2	—	ns
DS14	DSPI_SCK to DSPI_SIN input hold	7	—	ns
DS15	$\overline{DSPI\_SS}$ active to DSPI_SOUT driven	—	25	ns
DS16	$\overline{DSPI\_SS}$ inactive to DSPI_SOUT not driven	—	25	ns

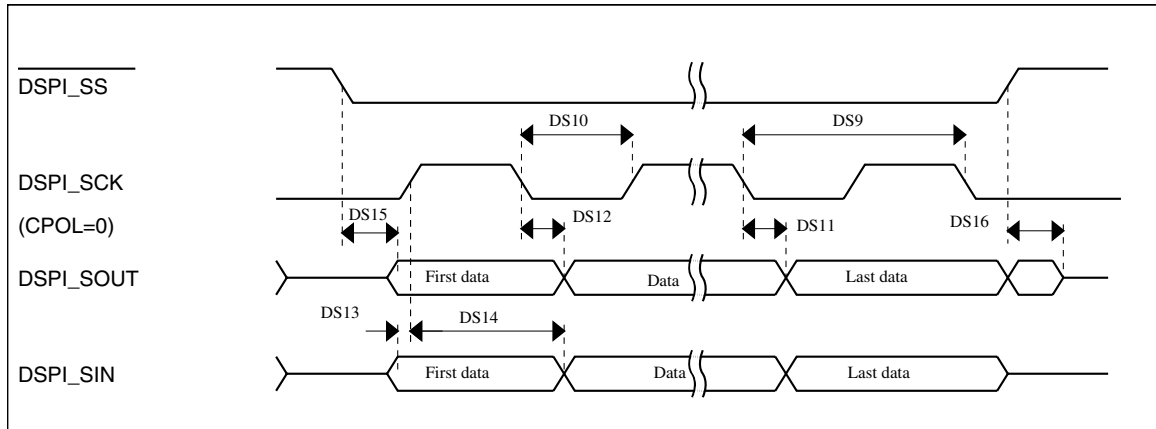

Figure 24. DSPI classic SPI timing — slave mode

### 3.8.5 Inter-Integrated Circuit Interface (I<sup>2</sup>C) timing

Table 42. I<sup>2</sup>C timing

Characteristic	Symbol	Standard Mode		Fast Mode		Unit
		Minimum	Maximum	Minimum	Maximum	
SCL Clock Frequency	$f_{SCL}$	0	100	0	400	kHz
Hold time (repeated) START condition. After this period, the first clock pulse is generated.	$t_{HD}; STA$	4	—	0.6	—	$\mu s$
LOW period of the SCL clock	$t_{LOW}$	4.7	—	1.3	—	$\mu s$
HIGH period of the SCL clock	$t_{HIGH}$	4	—	0.6	—	$\mu s$
Set-up time for a repeated START condition	$t_{SU}; STA$	4.7	—	0.6	—	$\mu s$
Data hold time for I <sup>2</sup> C bus devices	$t_{HD}; DAT$	0 <sup>1</sup>	3.45 <sup>2</sup>	0 <sup>3</sup>	0.9 <sup>1</sup>	$\mu s$
Data set-up time	$t_{SU}; DAT$	250 <sup>4</sup>	—	100 <sup>2, 5</sup>	—	ns
Rise time of SDA and SCL signals	$t_r$	—	1000	$20 + 0.1C_b$ <sup>6</sup>	300	ns
Fall time of SDA and SCL signals	$t_f$	—	300	$20 + 0.1C_b$ <sup>5</sup>	300	ns
Set-up time for STOP condition	$t_{SU}; STO$	4	—	0.6	—	$\mu s$
Bus free time between STOP and START condition	$t_{BUF}$	4.7	—	1.3	—	$\mu s$
Pulse width of spikes that must be suppressed by the input filter	$t_{SP}$	N/A	N/A	0	50	ns

1. The master mode I<sup>2</sup>C deasserts ACK of an address byte simultaneously with the falling edge of SCL. If no slaves acknowledge this address byte, then a negative hold time can result, depending on the edge rates of the SDA and SCL lines.
2. The maximum  $t_{HD}; DAT$  must be met only if the device does not stretch the LOW period ( $t_{LOW}$ ) of the SCL signal.
3. Input signal Slew = 10 ns and Output Load = 50 pF
4. Set-up time in slave-transmitter mode is 1 IPBus clock period, if the TX FIFO is empty.
5. A Fast mode I<sup>2</sup>C bus device can be used in a Standard mode I<sup>2</sup>C bus system, but the requirement  $t_{SU}; DAT \geq 250$  ns must then be met. This is automatically the case if the device does not stretch the LOW period of the SCL signal. If

## Peripheral operating requirements and behaviors

such a device does stretch the LOW period of the SCL signal, then it must output the next data bit to the SDA line  $t_{rmax} + t_{SU; DAT} = 1000 + 250 = 1250$  ns (according to the Standard mode I<sup>2</sup>C bus specification) before the SCL line is released.

6.  $C_b$  = total capacitance of the one bus line in pF.

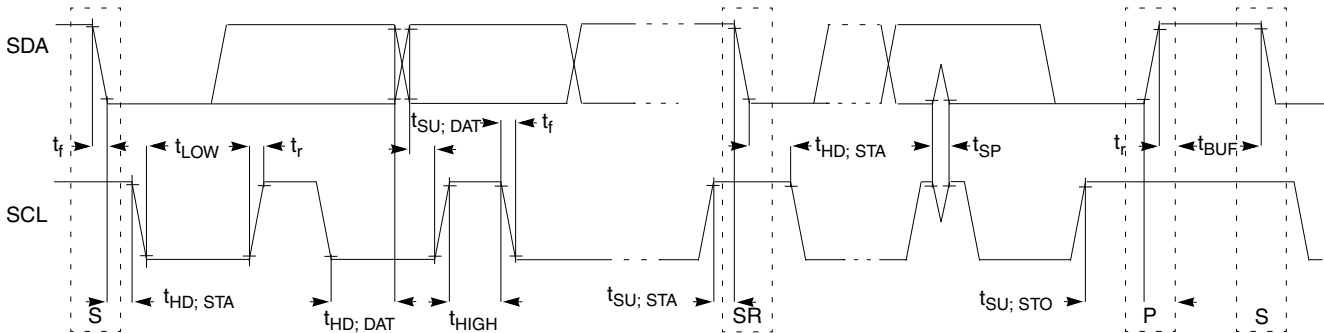

**Figure 25. Timing definition for fast and standard mode devices on the I<sup>2</sup>C bus**

## 3.8.6 UART switching specifications

See [General switching specifications](#).

## 3.8.7 I2S/SAI switching specifications

This section provides the AC timing for the I2S/SAI module in master mode (clocks are driven) and slave mode (clocks are input). All timing is given for noninverted serial clock polarity (TCR2[BCP] is 0, RCR2[BCP] is 0) and a noninverted frame sync (TCR4[FSP] is 0, RCR4[FSP] is 0). If the polarity of the clock and/or the frame sync have been inverted, all the timing remains valid by inverting the bit clock signal (BCLK) and/or the frame sync (FS) signal shown in the following figures.

### 3.8.7.1 Normal Run, Wait and Stop mode performance over a limited operating voltage range

This section provides the operating performance over a limited operating voltage for the device in Normal Run, Wait and Stop modes.

**Table 43. I2S/SAI master mode timing in Normal Run, Wait and Stop modes (limited voltage range)**

Num.	Characteristic	Min.	Max.	Unit
	Operating voltage	2.7	3.6	V
S1	I2S_MCLK cycle time	40	—	ns

*Table continues on the next page...*

**Table 43. I2S/SAI master mode timing in Normal Run, Wait and Stop modes (limited voltage range) (continued)**

Num.	Characteristic	Min.	Max.	Unit
S2	I2S_MCLK pulse width high/low	45%	55%	MCLK period
S3	I2S_TX_BCLK/I2S_RX_BCLK cycle time (output)	80	—	ns
S4	I2S_TX_BCLK/I2S_RX_BCLK pulse width high/low	45%	55%	BCLK period
S5	I2S_TX_BCLK/I2S_RX_BCLK to I2S_TX_FS/ I2S_RX_FS output valid	—	15	ns
S6	I2S_TX_BCLK/I2S_RX_BCLK to I2S_TX_FS/ I2S_RX_FS output invalid	0	—	ns
S7	I2S_TX_BCLK to I2S_TXD valid	—	15	ns
S8	I2S_TX_BCLK to I2S_TXD invalid	0	—	ns
S9	I2S_RXD/I2S_RX_FS input setup before I2S_RX_BCLK	18	—	ns
S10	I2S_RXD/I2S_RX_FS input hold after I2S_RX_BCLK	0	—	ns

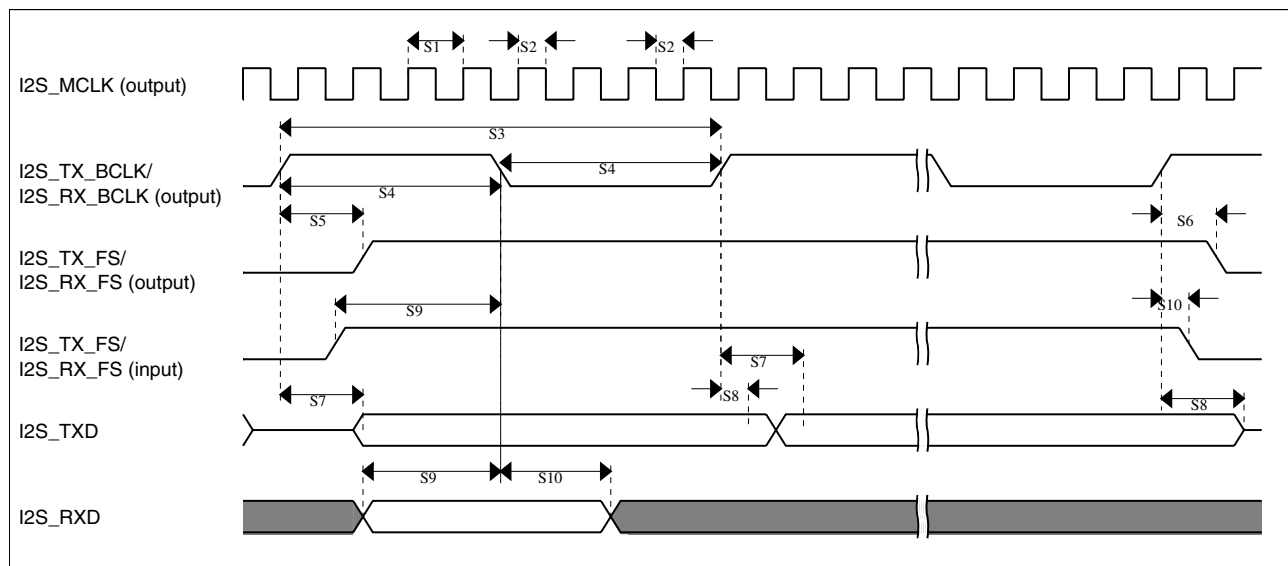
**Figure 26. I2S/SAI timing — master modes****Table 44. I2S/SAI slave mode timing in Normal Run, Wait and Stop modes (limited voltage range)**

Num.	Characteristic	Min.	Max.	Unit
	Operating voltage	2.7	3.6	V
S11	I2S_TX_BCLK/I2S_RX_BCLK cycle time (input)	80	—	ns
S12	I2S_TX_BCLK/I2S_RX_BCLK pulse width high/low (input)	45%	55%	MCLK period

Table continues on the next page...

**Table 44. I2S/SAI slave mode timing in Normal Run, Wait and Stop modes (limited voltage range) (continued)**

Num.	Characteristic	Min.	Max.	Unit
S13	I2S_TX_FS/I2S_RX_FS input setup before I2S_TX_BCLK/I2S_RX_BCLK	4.5	—	ns
S14	I2S_TX_FS/I2S_RX_FS input hold after I2S_TX_BCLK/I2S_RX_BCLK	2	—	ns
S15	I2S_TX_BCLK to I2S_TXD/I2S_TX_FS output valid	—	20	ns
S16	I2S_TX_BCLK to I2S_TXD/I2S_TX_FS output invalid	0	—	ns
S17	I2S_RXD setup before I2S_RX_BCLK	4.5	—	ns
S18	I2S_RXD hold after I2S_RX_BCLK	2	—	ns
S19	I2S_TX_FS input assertion to I2S_TXD output valid <sup>1</sup>	—	25	ns

1. Applies to first bit in each frame and only if the TCR4[FSE] bit is clear

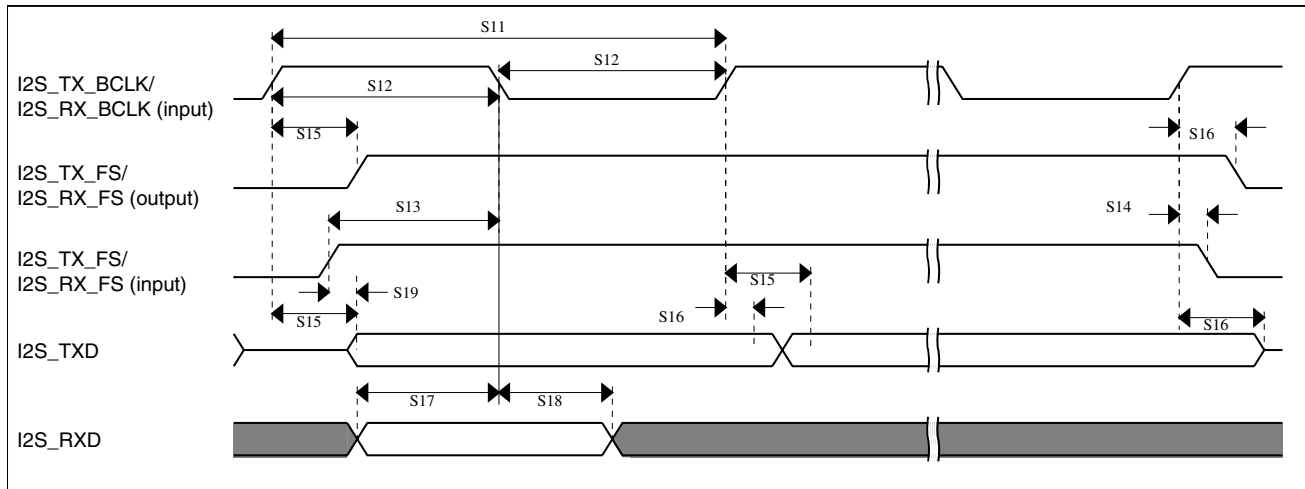

**Figure 27. I2S/SAI timing — slave modes**

### 3.8.7.2 Normal Run, Wait and Stop mode performance over the full operating voltage range

This section provides the operating performance over the full operating voltage for the device in Normal Run, Wait and Stop modes.

**Table 45. I2S/SAI master mode timing in Normal Run, Wait and Stop modes (full voltage range)**

Num.	Characteristic	Min.	Max.	Unit
	Operating voltage	1.71	3.6	V
S1	I2S_MCLK cycle time	40	—	ns

Table continues on the next page...

**Table 45. I2S/SAI master mode timing in Normal Run, Wait and Stop modes (full voltage range) (continued)**

Num.	Characteristic	Min.	Max.	Unit
S2	I2S_MCLK pulse width high/low	45%	55%	MCLK period
S3	I2S_TX_BCLK/I2S_RX_BCLK cycle time (output)	80	—	ns
S4	I2S_TX_BCLK/I2S_RX_BCLK pulse width high/low	45%	55%	BCLK period
S5	I2S_TX_BCLK/I2S_RX_BCLK to I2S_TX_FS/ I2S_RX_FS output valid	—	15	ns
S6	I2S_TX_BCLK/I2S_RX_BCLK to I2S_TX_FS/ I2S_RX_FS output invalid	-1.0	—	ns
S7	I2S_TX_BCLK to I2S_TXD valid	—	15	ns
S8	I2S_TX_BCLK to I2S_TXD invalid	0	—	ns
S9	I2S_RXD/I2S_RX_FS input setup before I2S_RX_BCLK	27	—	ns
S10	I2S_RXD/I2S_RX_FS input hold after I2S_RX_BCLK	0	—	ns

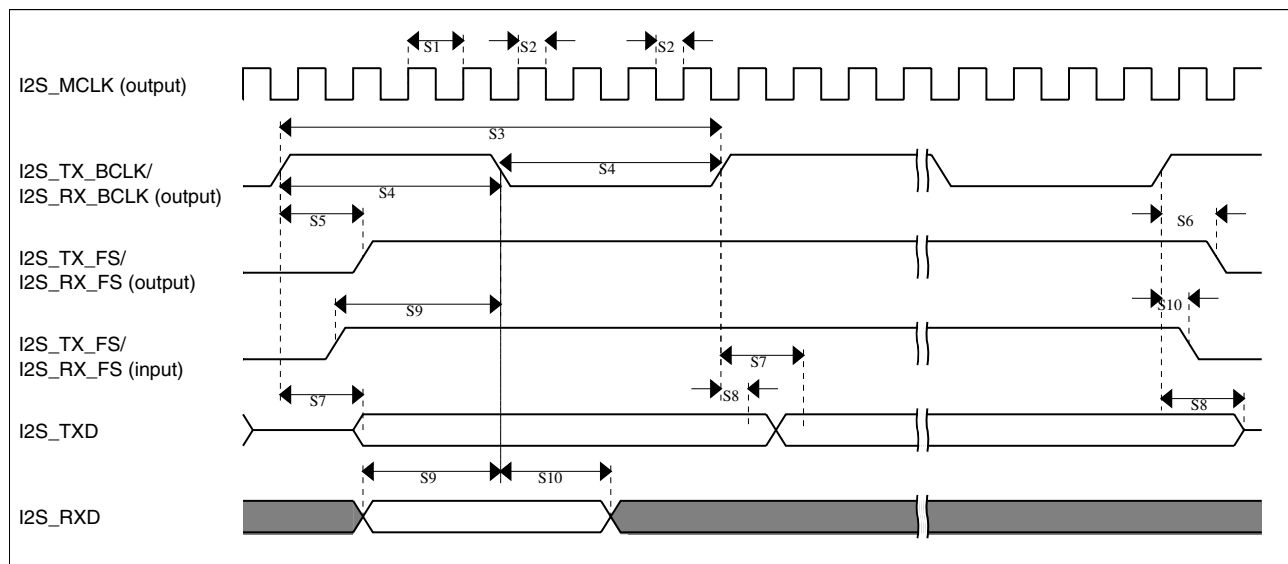
**Figure 28. I2S/SAI timing — master modes****Table 46. I2S/SAI slave mode timing in Normal Run, Wait and Stop modes (full voltage range)**

Num.	Characteristic	Min.	Max.	Unit
	Operating voltage	1.71	3.6	V
S11	I2S_TX_BCLK/I2S_RX_BCLK cycle time (input)	80	—	ns
S12	I2S_TX_BCLK/I2S_RX_BCLK pulse width high/low (input)	45%	55%	MCLK period

Table continues on the next page...

**Table 46. I2S/SAI slave mode timing in Normal Run, Wait and Stop modes (full voltage range) (continued)**

Num.	Characteristic	Min.	Max.	Unit
S13	I2S_TX_FS/I2S_RX_FS input setup before I2S_TX_BCLK/I2S_RX_BCLK	5.8	—	ns
S14	I2S_TX_FS/I2S_RX_FS input hold after I2S_TX_BCLK/I2S_RX_BCLK	2	—	ns
S15	I2S_TX_BCLK to I2S_TXD/I2S_TX_FS output valid	—	28.5	ns
S16	I2S_TX_BCLK to I2S_TXD/I2S_TX_FS output invalid	0	—	ns
S17	I2S_RXD setup before I2S_RX_BCLK	5.8	—	ns
S18	I2S_RXD hold after I2S_RX_BCLK	2	—	ns
S19	I2S_TX_FS input assertion to I2S_TXD output valid <sup>1</sup>	—	26.3	ns

1. Applies to first bit in each frame and only if the TCR4[FSE] bit is clear

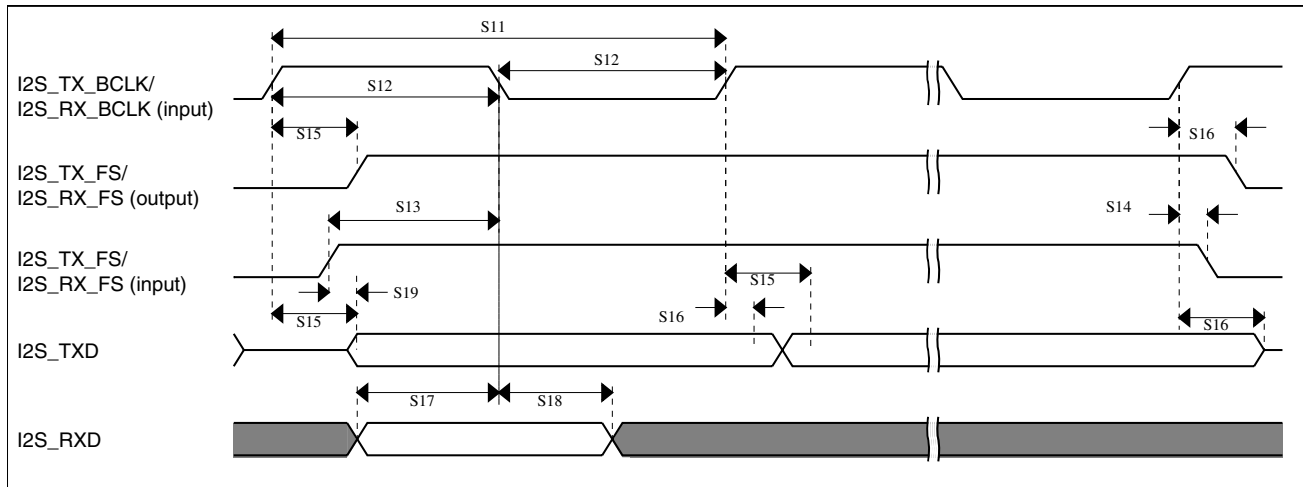

**Figure 29. I2S/SAI timing — slave modes**

### 3.8.7.3 VLPR, VLPW, and VLPS mode performance over the full operating voltage range

This section provides the operating performance over the full operating voltage for the device in VLPR, VLPW, and VLPS modes.

**Table 47. I2S/SAI master mode timing in VLPR, VLPW, and VLPS modes (full voltage range)**

Num.	Characteristic	Min.	Max.	Unit
	Operating voltage	1.71	3.6	V
S1	I2S_MCLK cycle time	62.5	—	ns

Table continues on the next page...



**Table 47. I2S/SAI master mode timing in VLPR, VLPW, and VLPS modes (full voltage range) (continued)**

Num.	Characteristic	Min.	Max.	Unit
S2	I2S_MCLK pulse width high/low	45%	55%	MCLK period
S3	I2S_TX_BCLK/I2S_RX_BCLK cycle time (output)	250	—	ns
S4	I2S_TX_BCLK/I2S_RX_BCLK pulse width high/low	45%	55%	BCLK period
S5	I2S_TX_BCLK/I2S_RX_BCLK to I2S_TX_FS/ I2S_RX_FS output valid	—	45	ns
S6	I2S_TX_BCLK/I2S_RX_BCLK to I2S_TX_FS/ I2S_RX_FS output invalid	-1	—	ns
S7	I2S_TX_BCLK to I2S_TXD valid	—	45	ns
S8	I2S_TX_BCLK to I2S_TXD invalid	0	—	ns
S9	I2S_RXD/I2S_RX_FS input setup before I2S_RX_BCLK	45	—	ns
S10	I2S_RXD/I2S_RX_FS input hold after I2S_RX_BCLK	0	—	ns

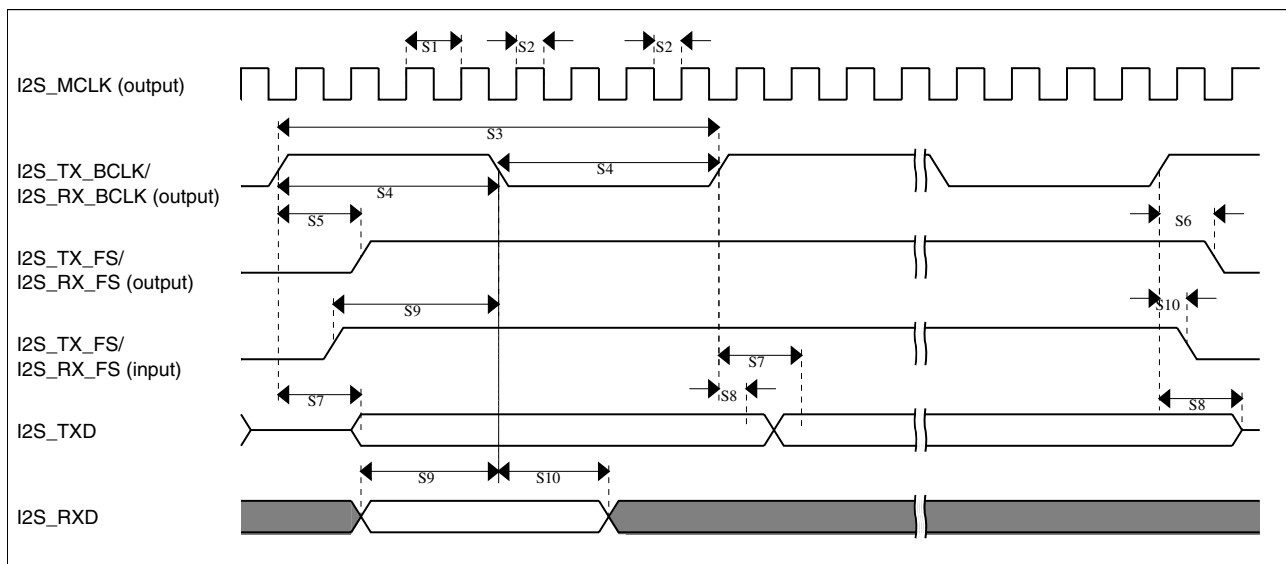
**Figure 30. I2S/SAI timing — master modes****Table 48. I2S/SAI slave mode timing in VLPR, VLPW, and VLPS modes (full voltage range)**

Num.	Characteristic	Min.	Max.	Unit
	Operating voltage	1.71	3.6	V
S11	I2S_TX_BCLK/I2S_RX_BCLK cycle time (input)	250	—	ns
S12	I2S_TX_BCLK/I2S_RX_BCLK pulse width high/low (input)	45%	55%	MCLK period

Table continues on the next page...

**Table 48. I2S/SAI slave mode timing in VLPR, VLPW, and VLPS modes (full voltage range) (continued)**

Num.	Characteristic	Min.	Max.	Unit
S13	I2S_TX_FS/I2S_RX_FS input setup before I2S_TX_BCLK/I2S_RX_BCLK	30	—	ns
S14	I2S_TX_FS/I2S_RX_FS input hold after I2S_TX_BCLK/I2S_RX_BCLK	7	—	ns
S15	I2S_TX_BCLK to I2S_TXD/I2S_TX_FS output valid	—	63	ns
S16	I2S_TX_BCLK to I2S_TXD/I2S_TX_FS output invalid	0	—	ns
S17	I2S_RXD setup before I2S_RX_BCLK	30	—	ns
S18	I2S_RXD hold after I2S_RX_BCLK	4	—	ns
S19	I2S_TX_FS input assertion to I2S_TXD output valid <sup>1</sup>	—	72	ns

1. Applies to first bit in each frame and only if the TCR4[FSE] bit is clear

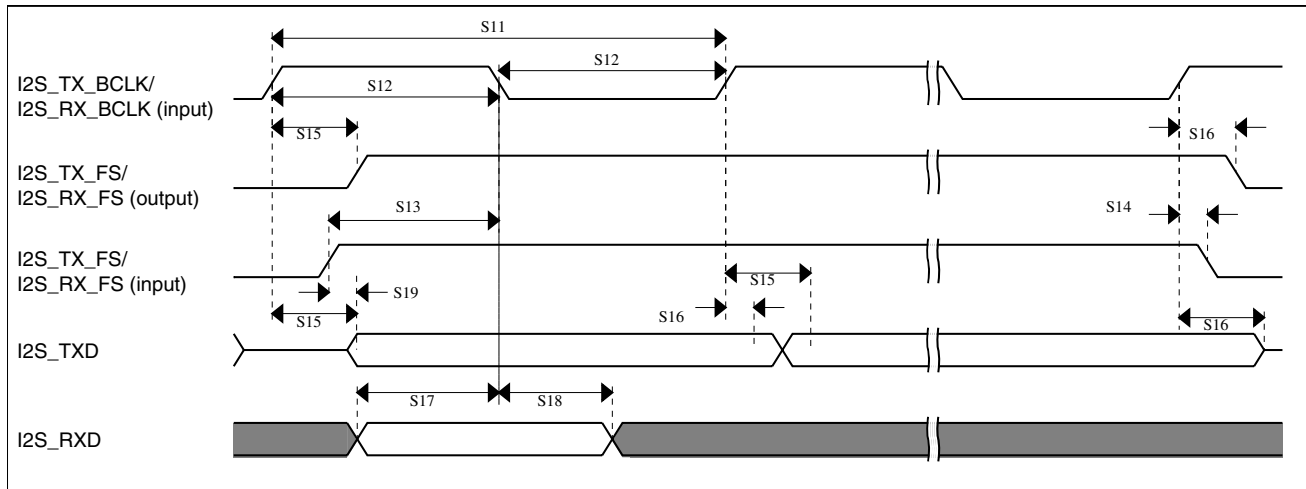

**Figure 31. I2S/SAI timing — slave modes**

## 4 Dimensions

### 4.1 Obtaining package dimensions

Package dimensions are provided in package drawings.

To find a package drawing, go to [freescale.com](http://freescale.com) and perform a keyword search for the drawing's document number:

If you want the drawing for this package	Then use this document number
64-pin LQFP	98ASS23234W
64-pin MAPBGA	98ASA00420D
100-pin LQFP	98ASS23308W
121-pin XFBGA	98ASA00595D

## 5 Pinout

### 5.1 K22F Signal Multiplexing and Pin Assignments

The following table shows the signals available on each pin and the locations of these pins on the devices supported by this document. The Port Control Module is responsible for selecting which ALT functionality is available on each pin.

121 BGA	100 LQFP	64 LQFP	64 MAP BGA	Pin Name	Default	ALT0	ALT1	ALT2	ALT3	ALT4	ALT5	ALT6	ALT7	EzPort
E4	1	1	A1	PTE0/ CLKOUT32 K	ADC1_SE4a	ADC1_SE4a	PTE0/ CLKOUT32 K	SPI1_PCS1	UART1_TX			I2C1_SDA	RTC_ CLKOUT	
E3	2	2	B1	PTE1/ LLWU_P0	ADC1_SE5a	ADC1_SE5a	PTE1/ LLWU_P0	SPI1_SOUT	UART1_RX			I2C1_SCL	SPI1_SIN	
E2	3	—	—	PTE2/ LLWU_P1	ADC1_SE6a	ADC1_SE6a	PTE2/ LLWU_P1	SPI1_SCK	UART1_ CTS_b					
F4	4	—	—	PTE3	ADC1_SE7a	ADC1_SE7a	PTE3	SPI1_SIN	UART1_ RTS_b				SPI1_SOUT	
H7	5	—	—	PTE4/ LLWU_P2	DISABLED		PTE4/ LLWU_P2	SPI1_PCS0	LPUART0_ TX					
G4	6	—	—	PTE5	DISABLED		PTE5	SPI1_PCS2	LPUART0_ RX			FTM3_CH0		
F3	7	—	—	PTE6	DISABLED		PTE6	SPI1_PCS3	LPUART0_ CTS_b	I2S0_MCLK		FTM3_CH1	USB_SOF_ OUT	
E6	8	3	C5	VDD	VDD	VDD								
G7	9	4	C4	VSS	VSS	VSS								
L6	—	—	—	VSS	VSS	VSS								
F1	10	5	E1	USB0_DP	USB0_DP	USB0_DP								
F2	11	6	D1	USB0_DM	USB0_DM	USB0_DM								
G1	12	7	E2	VOUT33	VOUT33	VOUT33								
G2	13	8	D2	VREGIN	VREGIN	VREGIN								
H1	14	—	—	ADC0_DP1	ADC0_DP1	ADC0_DP1								
H2	15	—	—	ADC0_DM1	ADC0_DM1	ADC0_DM1								

## Pinout

121 BGA	100 LQFP	64 LQFP	64 MAP BGA	Pin Name	Default	ALT0	ALT1	ALT2	ALT3	ALT4	ALT5	ALT6	ALT7	EzPort
J1	16	—	—	ADC1_DP1/ ADC0_DP2	ADC1_DP1/ ADC0_DP2	ADC1_DP1/ ADC0_DP2								
J2	17	—	—	ADC1_DM1/ ADC0_DM2	ADC1_DM1/ ADC0_DM2	ADC1_DM1/ ADC0_DM2								
K1	18	9	G1	ADC0_DP0/ ADC1_DP3	ADC0_DP0/ ADC1_DP3	ADC0_DP0/ ADC1_DP3								
K2	19	10	F1	ADC0_DM0/ ADC1_DM3	ADC0_DM0/ ADC1_DM3	ADC0_DM0/ ADC1_DM3								
L1	20	11	G2	ADC1_DP0/ ADC0_DP3	ADC1_DP0/ ADC0_DP3	ADC1_DP0/ ADC0_DP3								
L2	21	12	F2	ADC1_DM0/ ADC0_DM3	ADC1_DM0/ ADC0_DM3	ADC1_DM0/ ADC0_DM3								
F5	22	13	F4	VDDA	VDDA	VDDA								
G5	23	14	G4	VREFH	VREFH	VREFH								
G6	24	15	G3	VREFL	VREFL	VREFL								
F6	25	16	F3	VSSA	VSSA	VSSA								
J3	—	—	—	ADC1_ SE16/ ADC0_SE22	ADC1_ SE16/ ADC0_SE22	ADC1_ SE16/ ADC0_SE22								
H3	—	—	—	ADC0_ SE16/ CMP1_IN2/ ADC0_SE21	ADC0_ SE16/ CMP1_IN2/ ADC0_SE21	ADC0_ SE16/ CMP1_IN2/ ADC0_SE21								
L3	26	17	H1	VREF_OUT/ CMP1_IN5/ CMP0_IN5/ ADC1_SE18	VREF_OUT/ CMP1_IN5/ CMP0_IN5/ ADC1_SE18	VREF_OUT/ CMP1_IN5/ CMP0_IN5/ ADC1_SE18								
K5	27	18	H2	DAC0_OUT/ CMP1_IN3/ ADC0_SE23	DAC0_OUT/ CMP1_IN3/ ADC0_SE23	DAC0_OUT/ CMP1_IN3/ ADC0_SE23								
K4	—	—	—	DAC1_OUT/ CMP0_IN4/ ADC1_SE23	DAC1_OUT/ CMP0_IN4/ ADC1_SE23	DAC1_OUT/ CMP0_IN4/ ADC1_SE23								
L7	—	—	—	RTC_ WAKEUP_B	RTC_ WAKEUP_B	RTC_ WAKEUP_B								
L4	28	19	H3	XTAL32	XTAL32	XTAL32								
L5	29	20	H4	EXTAL32	EXTAL32	EXTAL32								
K6	30	21	H5	VBAT	VBAT	VBAT								
H5	31	—	—	PTE24	ADC0_SE17	ADC0_SE17	PTE24				I2C0_SCL	EWM_OUT_b		
J5	32	—	—	PTE25	ADC0_SE18	ADC0_SE18	PTE25				I2C0_SDA	EWM_IN		
H6	33	—	—	PTE26/ CLKOUT32 K	DISABLED		PTE26/ CLKOUT32 K					RTC_ CLKOUT	USB_CLKIN	

121 BGA	100 LQFP	64 LQFP	64 MAP BGA	Pin Name	Default	ALT0	ALT1	ALT2	ALT3	ALT4	ALT5	ALT6	ALT7	EzPort
J6	34	22	D3	PTA0	JTAG_TCLK/ SWD_CLK/ EZP_CLK		PTA0	UART0_CTS_b	FTM0_CH5				JTAG_TCLK/ SWD_CLK	EZP_CLK
H8	35	23	D4	PTA1	JTAG_TDI/ EZP_DI		PTA1	UART0_RX	FTM0_CH6				JTAG_TDI	EZP_DI
J7	36	24	E5	PTA2	JTAG_TDO/ TRACE_SWO/ EZP_DO		PTA2	UART0_TX	FTM0_CH7				JTAG_TDO/ TRACE_SWO	EZP_DO
H9	37	25	D5	PTA3	JTAG_TMS/ SWD_DIO		PTA3	UART0_RTS_b	FTM0_CH0				JTAG_TMS/ SWD_DIO	
J8	38	26	G5	PTA4/ LLWU_P3	NMI_b/ EZP_CS_b		PTA4/ LLWU_P3		FTM0_CH1				NMI_b	EZP_CS_b
K7	39	27	F5	PTA5	DISABLED		PTA5	USB_CLKIN	FTM0_CH2			I2S0_TX_BCLK	JTAG_TRST_b	
E5	40	—	—	VDD	VDD	VDD								
G3	41	—	—	VSS	VSS	VSS								
J9	—	—	—	PTA10	DISABLED		PTA10		FTM2_CH0			FTM2_QD_PHA		
J4	—	—	—	PTA11	DISABLED		PTA11		FTM2_CH1			FTM2_QD_PHB		
K8	42	28	H6	PTA12	DISABLED		PTA12		FTM1_CH0			I2S0_TXD0	FTM1_QD_PHA	
L8	43	29	G6	PTA13/ LLWU_P4	DISABLED		PTA13/ LLWU_P4		FTM1_CH1			I2S0_TX_FS	FTM1_QD_PHB	
K9	44	—	—	PTA14	DISABLED		PTA14	SPI0_PCS0	UART0_TX			I2S0_RX_BCLK		
L9	45	—	—	PTA15	DISABLED		PTA15	SPI0_SCK	UART0_RX			I2S0_RXD0		
J10	46	—	—	PTA16	DISABLED		PTA16	SPI0_SOUT	UART0_CTS_b			I2S0_RX_FS		
H10	47	—	—	PTA17	ADC1_SE17	ADC1_SE17	PTA17	SPI0_SIN	UART0_RTS_b			I2S0_MCLK		
L10	48	30	G7	VDD	VDD	VDD								
K10	49	31	H7	VSS	VSS	VSS								
L11	50	32	H8	PTA18	EXTAL0	EXTAL0	PTA18		FTM0_FLT2	FTM_CLKIN0				
K11	51	33	G8	PTA19	XTAL0	XTAL0	PTA19		FTM1_FLT0	FTM_CLKIN1		LPTMR0_ALT1		
J11	52	34	F8	RESET_b	RESET_b	RESET_b								
H11	—	—	—	PTA29	DISABLED		PTA29					FB_A24		
G11	53	35	F7	PTB0/ LLWU_P5	ADC0_SE8/ ADC1_SE8	ADC0_SE8/ ADC1_SE8	PTB0/ LLWU_P5	I2C0_SCL	FTM1_CH0			FTM1_QD_PHA		
G10	54	36	F6	PTB1	ADC0_SE9/ ADC1_SE9	ADC0_SE9/ ADC1_SE9	PTB1	I2C0_SDA	FTM1_CH1			FTM1_QD_PHB		

## Pinout

121 BGA	100 LQFP	64 LQFP	64 MAP BGA	Pin Name	Default	ALT0	ALT1	ALT2	ALT3	ALT4	ALT5	ALT6	ALT7	EzPort
G9	55	37	E7	PTB2	ADC0_SE12	ADC0_SE12	PTB2	I2C0_SCL	UART0_RTS_b			FTM0_FLT3		
G8	56	38	E8	PTB3	ADC0_SE13	ADC0_SE13	PTB3	I2C0_SDA	UART0_CTS_b			FTM0_FLT0		
F11	—	—	—	PTB6	ADC1_SE12	ADC1_SE12	PTB6				FB_AD23			
E11	—	—	—	PTB7	ADC1_SE13	ADC1_SE13	PTB7				FB_AD22			
D11	—	—	—	PTB8	DISABLED		PTB8		LPUART0_RTS_b		FB_AD21			
E10	57	—	—	PTB9	DISABLED		PTB9	SPI1_PCS1	LPUART0_CTS_b		FB_AD20			
D10	58	—	—	PTB10	ADC1_SE14	ADC1_SE14	PTB10	SPI1_PCS0	LPUART0_RX		FB_AD19	FTM0_FLT1		
C10	59	—	—	PTB11	ADC1_SE15	ADC1_SE15	PTB11	SPI1_SCK	LPUART0_TX		FB_AD18	FTM0_FLT2		
—	60	—	—	VSS	VSS	VSS								
—	61	—	—	VDD	VDD	VDD								
B10	62	39	E6	PTB16	DISABLED		PTB16	SPI1_SOUT	UART0_RX	FTM_CLKIN0	FB_AD17	EWM_IN		
E9	63	40	D7	PTB17	DISABLED		PTB17	SPI1_SIN	UART0_TX	FTM_CLKIN1	FB_AD16	EWM_OUT_b		
D9	64	41	D6	PTB18	DISABLED		PTB18		FTM2_CH0	I2S0_TX_BCLK	FB_AD15	FTM2_QD_PHA		
C9	65	42	C7	PTB19	DISABLED		PTB19		FTM2_CH1	I2S0_TX_FS	FB_OE_b	FTM2_QD_PHB		
F10	66	—	—	PTB20	DISABLED		PTB20				FB_AD31	CMP0_OUT		
F9	67	—	—	PTB21	DISABLED		PTB21				FB_AD30	CMP1_OUT		
F8	68	—	—	PTB22	DISABLED		PTB22				FB_AD29			
E8	69	—	—	PTB23	DISABLED		PTB23		SPI0_PCS5		FB_AD28			
B9	70	43	D8	PTC0	ADC0_SE14	ADC0_SE14	PTC0	SPI0_PCS4	PDB0_EXTRG	USB_SOF_OUT	FB_AD14			
D8	71	44	C6	PTC1/LLWU_P6	ADC0_SE15	ADC0_SE15	PTC1/LLWU_P6	SPI0_PCS3	UART1_RTS_b	FTM0_CH0	FB_AD13	I2S0_TXD0	LPUART0_RTS_b	
C8	72	45	B7	PTC2	ADC0_SE4b/ CMP1_IN0	ADC0_SE4b/ CMP1_IN0	PTC2	SPI0_PCS2	UART1_CTS_b	FTM0_CH1	FB_AD12	I2S0_TX_FS	LPUART0_CTS_b	
B8	73	46	C8	PTC3/LLWU_P7	CMP1_IN1	CMP1_IN1	PTC3/LLWU_P7	SPI0_PCS1	UART1_RX	FTM0_CH2	CLKOUT	I2S0_TX_BCLK	LPUART0_RX	
—	74	47	E3	VSS	VSS	VSS								
—	75	48	E4	VDD	VDD	VDD								
A8	76	49	B8	PTC4/LLWU_P8	DISABLED		PTC4/LLWU_P8	SPI0_PCS0	UART1_TX	FTM0_CH3	FB_AD11	CMP1_OUT	LPUART0_TX	
D7	77	50	A8	PTC5/LLWU_P9	DISABLED		PTC5/LLWU_P9	SPI0_SCK	LPTMR0_ALT2	I2S0_RXD0	FB_AD10	CMP0_OUT	FTM0_CH2	

121 BGA	100 LQFP	64 LQFP	64 MAP BGA	Pin Name	Default	ALT0	ALT1	ALT2	ALT3	ALT4	ALT5	ALT6	ALT7	EzPort
C7	78	51	A7	PTC6/ LLWU_P10	CMP0_IN0	CMP0_IN0	PTC6/ LLWU_P10	SPI0_SOUT	PDB0_ EXTRG	I2S0_RX_ BCLK	FB_AD9	I2S0_MCLK		
B7	79	52	B6	PTC7	CMP0_IN1	CMP0_IN1	PTC7	SPI0_SIN	USB_SOF_ OUT	I2S0_RX_ FS	FB_AD8			
A7	80	53	A6	PTC8	ADC1_ SE4b/ CMP0_IN2	ADC1_ SE4b/ CMP0_IN2	PTC8		FTM3_CH4	I2S0_MCLK	FB_AD7			
D6	81	54	B5	PTC9	ADC1_ SE5b/ CMP0_IN3	ADC1_ SE5b/ CMP0_IN3	PTC9		FTM3_CH5	I2S0_RX_ BCLK	FB_AD6	FTM2_FLT0		
C6	82	55	B4	PTC10	ADC1_SE6b	ADC1_SE6b	PTC10	I2C1_SCL	FTM3_CH6	I2S0_RX_ FS	FB_AD5			
C5	83	56	A5	PTC11/ LLWU_P11	ADC1_SE7b	ADC1_SE7b	PTC11/ LLWU_P11	I2C1_SDA	FTM3_CH7		FB_RW_b			
B6	84	—	—	PTC12	DISABLED		PTC12				FB_AD27	FTM3_FLT0		
A6	85	—	—	PTC13	DISABLED		PTC13				FB_AD26			
A5	86	—	—	PTC14	DISABLED		PTC14				FB_AD25			
B5	87	—	—	PTC15	DISABLED		PTC15				FB_AD24			
—	88	—	—	VSS	VSS	VSS								
—	89	—	—	VDD	VDD	VDD								
D5	90	—	—	PTC16	DISABLED		PTC16		LPUART0_ RX		FB_CS5_b/ FB_TSIZ1/ FB_BE23_ 16_BLS15_ 8_b			
C4	91	—	—	PTC17	DISABLED		PTC17		LPUART0_ TX		FB_CS4_b/ FB_TSIZ0/ FB_BE31_ 24_BLS7_ 0_b			
B4	92	—	—	PTC18	DISABLED		PTC18		LPUART0_ RTS_b		FB_TBST_ b/ FB_CS2_b/ FB_BE15_ 8_BLS23_ 16_b			
A4	—	—	—	PTC19	DISABLED		PTC19		LPUART0_ CTS_b		FB_CS3_b/ FB_BE7_0_ BLS31_24_ b	FB_TA_b		
D4	93	57	C3	PTD0/ LLWU_P12	DISABLED		PTD0/ LLWU_P12	SPI0_PCS0	UART2_ RTS_b	FTM3_CH0	FB_ALE/ FB_CS1_b/ FB_TS_b	LPUART0_ RTS_b		
D3	94	58	A4	PTD1	ADC0_SE5b	ADC0_SE5b	PTD1	SPI0_SCK	UART2_ CTS_b	FTM3_CH1	FB_CS0_b	LPUART0_ CTS_b		
C3	95	59	C2	PTD2/ LLWU_P13	DISABLED		PTD2/ LLWU_P13	SPI0_SOUT	UART2_RX	FTM3_CH2	FB_AD4	LPUART0_ RX	I2C0_SCL	

## Pinout

121 BGA	100 LQFP	64 LQFP	64 MAP BGA	Pin Name	Default	ALT0	ALT1	ALT2	ALT3	ALT4	ALT5	ALT6	ALT7	EzPort
B3	96	60	B3	PTD3	DISABLED		PTD3	SPI0_SIN	UART2_TX	FTM3_CH3	FB_AD3	LPUART0_TX	I2C0_SDA	
A3	97	61	A3	PTD4/LLWU_P14	DISABLED		PTD4/LLWU_P14	SPI0_PCS1	UART0_RTS_b	FTM0_CH4	FB_AD2	EWM_IN	SPI1_PCS0	
A2	98	62	C1	PTD5	ADC0_SE6b	ADC0_SE6b	PTD5	SPI0_PCS2	UART0_CTS_b	FTM0_CH5	FB_AD1	EWM_OUT_b	SPI1_SCK	
F7	—	—	—	VSS	VSS	VSS								
E7	—	—	—	VDD	VDD	VDD								
B2	99	63	B2	PTD6/LLWU_P15	ADC0_SE7b	ADC0_SE7b	PTD6/LLWU_P15	SPI0_PCS3	UART0_RX	FTM0_CH6	FB_AD0	FTM0_FLT0	SPI1_SOUT	
A1	100	64	A2	PTD7	DISABLED		PTD7		UART0_TX	FTM0_CH7		FTM0_FLT1	SPI1_SIN	
A10	—	—	—	PTD8	DISABLED		PTD8	I2C0_SCL			LPUART0_RX	FB_A16		
A9	—	—	—	PTD9	DISABLED		PTD9	I2C0_SDA			LPUART0_TX	FB_A17		
B1	—	—	—	PTD10	DISABLED		PTD10				LPUART0_RTS_b	FB_A18		
C2	—	—	—	PTD11	DISABLED		PTD11				LPUART0_CTS_b	FB_A19		
C1	—	—	—	PTD12	DISABLED		PTD12		FTM3_FLT0			FB_A20		
D2	—	—	—	PTD13	DISABLED		PTD13					FB_A21		
D1	—	—	—	PTD14	DISABLED		PTD14					FB_A22		
E1	—	—	—	PTD15	DISABLED		PTD15					FB_A23		
A11	—	—	—	NC	NC	NC								
K3	—	—	—	NC	NC	NC								
H4	—	—	—	NC	NC	NC								
B11	—	—	—	NC	NC	NC								
C11	—	—	—	NC	NC	NC								

## 5.2 K22 Pinouts

The following figure shows the pinout diagram for the devices supported by this document. Many signals may be multiplexed onto a single pin. To determine what signals can be used on which pin, see the previous section.



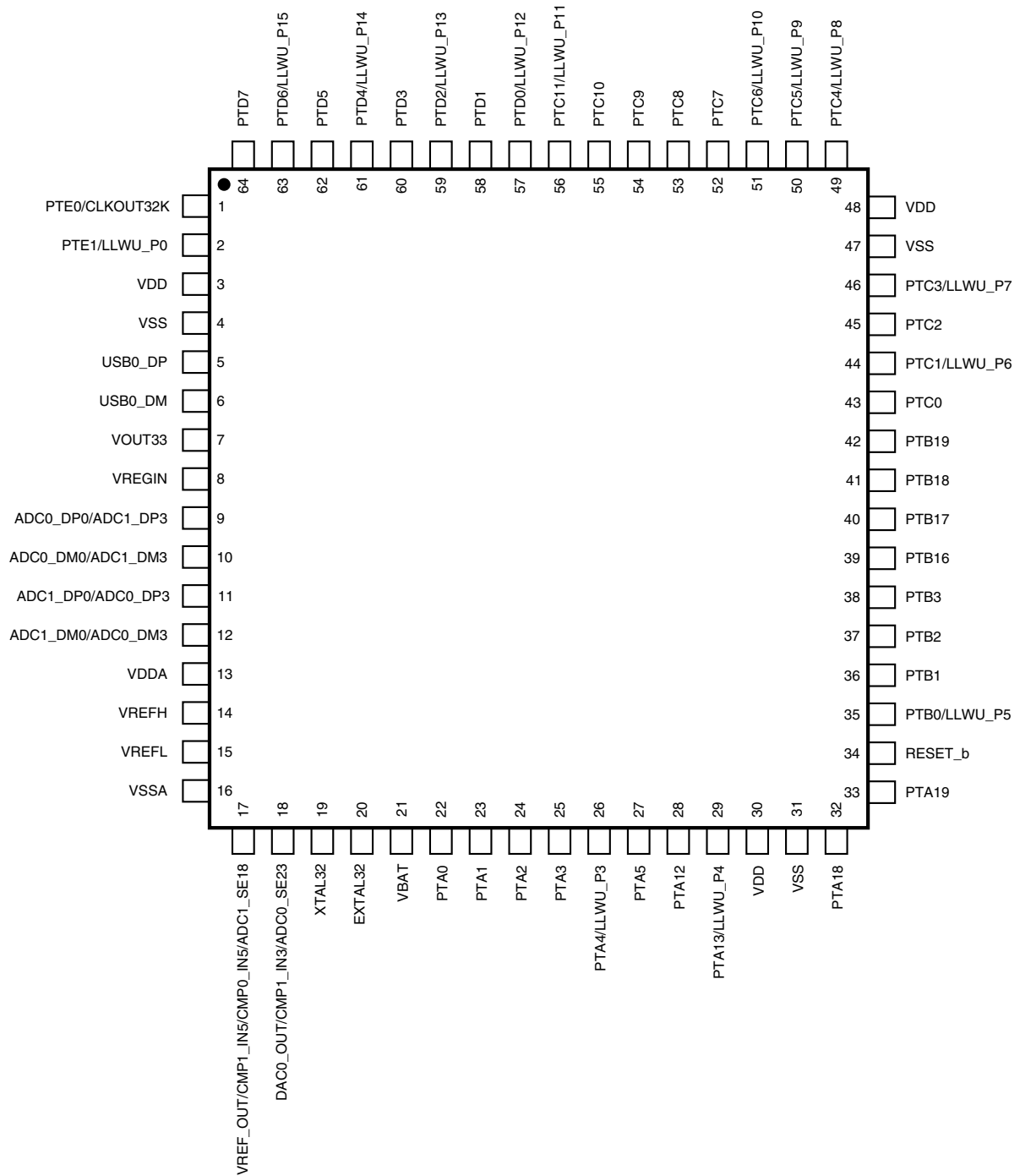

Figure 32. K22F 64 LQFP Pinout Diagram

# Pinout

	1	2	3	4	5	6	7	8	
A	PTE0/ CLKOUT32K	PTD7	PTD4/ LLWU_P14	PTD1	PTC11/ LLWU_P11	PTC8	PTC6/ LLWU_P10	PTC5/ LLWU_P9	A
B	PTE1/ LLWU_P0	PTD6/ LLWU_P15	PTD3	PTC10	PTC9	PTC7	PTC2	PTC4/ LLWU_P8	B
C	PTD5	PTD2/ LLWU_P13	PTD0/ LLWU_P12	VSS	VDD	PTC1/ LLWU_P6	PTB19	PTC3/ LLWU_P7	C
D	USB0_DM	VREGIN	PTA0	PTA1	PTA3	PTB18	PTB17	PTC0	D
E	USB0_DP	VOUT33	VSS	VDD	PTA2	PTB16	PTB2	PTB3	E
F	ADC0_DM0/ ADC1_DM3	ADC1_DM0/ ADC0_DM3	VSSA	VDDA	PTA5	PTB1	PTB0/ LLWU_P5	RESET_b	F
G	ADC0_DP0/ ADC1_DP3	ADC1_DP0/ ADC0_DP3	VREFL	VREFH	PTA4/ LLWU_P3	PTA13/ LLWU_P4	VDD	PTA19	G
H	VREF_OUT/ CMP1_IN5/ CMPO_IN5/ ADC1_SE18	DAC0_OUT/ CMP1_IN3/ ADC0_SE23	XTAL32	EXTAL32	VBAT	PTA12	VSS	PTA18	H
	1	2	3	4	5	6	7	8	

**Figure 33. K22 64 MAPBGA Pinout Diagram**

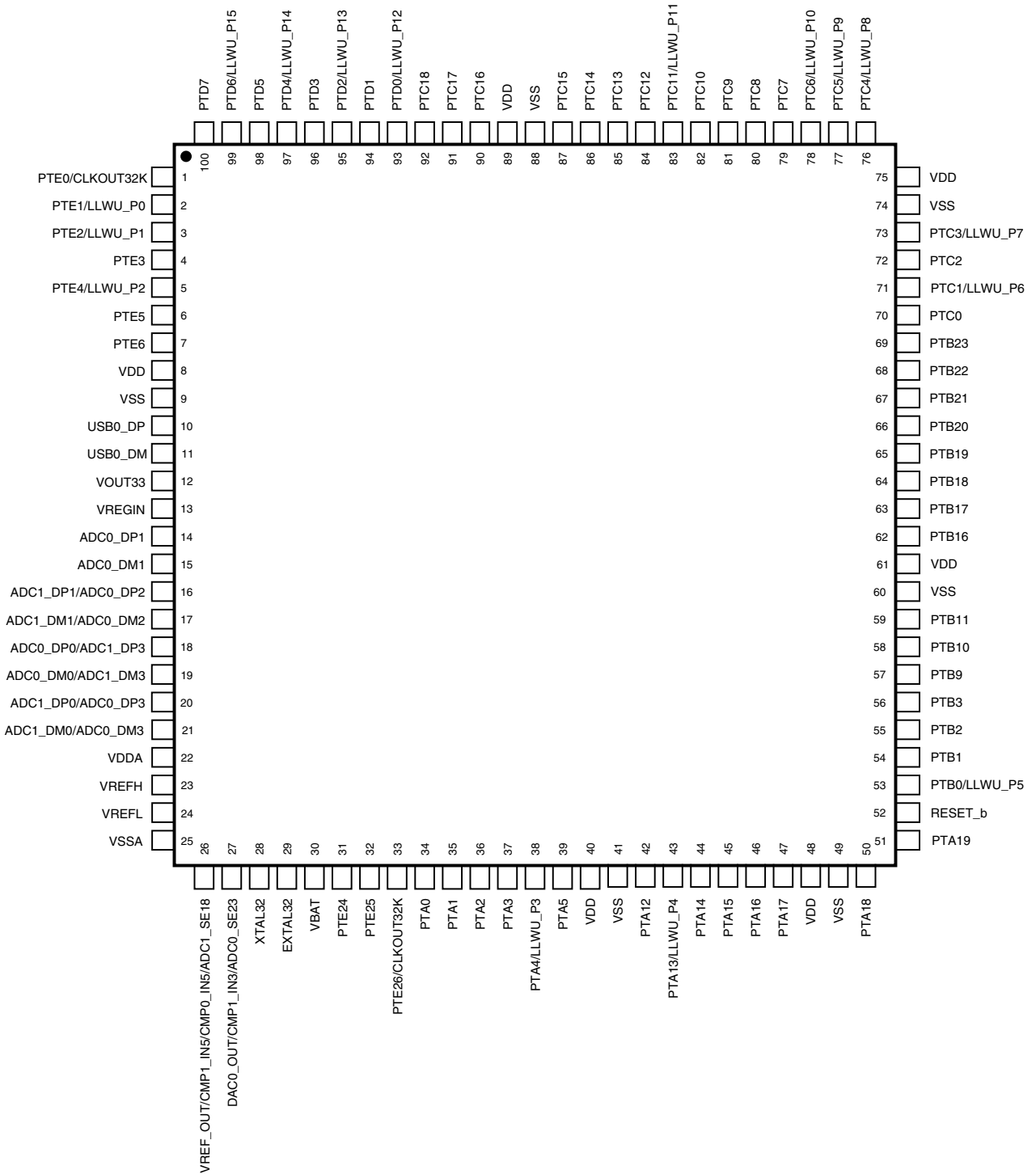

Figure 34. K22F 100 LQFP Pinout Diagram

## Ordering parts

	1	2	3	4	5	6	7	8	9	10	11	
A	PTD7	PTD5	PTD4/ LLWU_P14	PTC19	PTC14	PTC13	PTC8	PTC4/ LLWU_P8	PTD9	PTD8	NC	A
B	PTD10	PTD6/ LLWU_P15	PTD3	PTC18	PTC15	PTC12	PTC7	PTC3/ LLWU_P7	PTC0	PTB16	NC	B
C	PTD12	PTD11	PTD2/ LLWU_P13	PTC17	PTC11/ LLWU_P11	PTC10	PTC6/ LLWU_P10	PTC2	PTB19	PTB11	NC	C
D	PTD14	PTD13	PTD1	PTD0/ LLWU_P12	PTC16	PTC9	PTC5/ LLWU_P9	PTC1/ LLWU_P6	PTB18	PTB10	PTB8	D
E	PTD15	PTE2/ LLWU_P1	PTE1/ LLWU_P0	PTE0/ CLKOUT32K	VDD	VDD	VDD	PTB23	PTB17	PTB9	PTB7	E
F	USB0_DP	USB0_DM	PTE6	PTE3	VDDA	VSSA	VSS	PTB22	PTB21	PTB20	PTB6	F
G	VOUT33	VREGIN	VSS	PTE5	VREFH	VREFL	VSS	PTB3	PTB2	PTB1	PTB0/ LLWU_P5	G
H	ADC0_DP1	ADC0_DM1	ADC0_SE16/ CMP1_IN2/ ADC0_SE21	NC	PTE24	PTE26/ CLKOUT32K	PTE4/ LLWU_P2	PTA1	PTA3	PTA17	PTA29	H
J	ADC1_DP1/ ADC0_DP2	ADC1_DM1/ ADC0_DM2	ADC1_SE16/ ADC0_SE22	PTA11	PTE25	PTA0	PTA2	PTA4/ LLWU_P3	PTA10	PTA16	RESET_b	J
K	ADC0_DP0/ ADC1_DP3	ADC0_DM0/ ADC1_DM3	NC	DAC1_OUT/ CMP0_IN4/ ADC1_SE23	DAC0_OUT/ CMP1_IN3/ ADC0_SE23	VBAT	PTA5	PTA12	PTA14	VSS	PTA19	K
L	ADC1_DP0/ ADC0_DP3	ADC1_DM0/ ADC0_DM3	VREF_OUT/ CMP1_IN5/ CMP0_IN5/ ADC1_SE18	XTAL32	EXTAL32	VSS	RTC_ WAKEUP_B	PTA13/ LLWU_P4	PTA15	VDD	PTA18	L
	1	2	3	4	5	6	7	8	9	10	11	

Figure 35. K22F 121 XFBGA Pinout Diagram

## 6 Ordering parts

### 6.1 Determining valid orderable parts

Valid orderable part numbers are provided on the web. To determine the orderable part numbers for this device, go to [freescale.com](http://freescale.com) and perform a part number search for the following device numbers: PK22 and MK22 .

## 7 Part identification

### 7.1 Description

Part numbers for the chip have fields that identify the specific part. You can use the values of these fields to determine the specific part you have received.

### 7.2 Format

Part numbers for this device have the following format:

Q K## A M FFF R T PP CC N

### 7.3 Fields

This table lists the possible values for each field in the part number (not all combinations are valid):

Field	Description	Values
Q	Qualification status	<ul style="list-style-type: none"> <li>M = Fully qualified, general market flow, full reel</li> <li>P = Prequalification</li> <li>K = Fully qualified, general market flow, 100 piece reel</li> </ul>
K##	Kinetis family	<ul style="list-style-type: none"> <li>K22</li> </ul>
A	Key attribute	<ul style="list-style-type: none"> <li>D = Cortex-M4 w/ DSP</li> <li>F = Cortex-M4 w/ DSP and FPU</li> </ul>
M	Flash memory type	<ul style="list-style-type: none"> <li>N = Program flash only</li> <li>X = Program flash and FlexMemory</li> </ul>
FFF	Program flash memory size	<ul style="list-style-type: none"> <li>128 = 128 KB</li> <li>256 = 256 KB</li> <li>512 = 512 KB</li> </ul>
R	Silicon revision	<ul style="list-style-type: none"> <li>Z = Initial</li> <li>(Blank) = Main</li> <li>A = Revision after main</li> </ul>
T	Temperature range (°C)	<ul style="list-style-type: none"> <li>V = -40 to 105</li> <li>C = -40 to 85</li> </ul>
PP	Package identifier	<ul style="list-style-type: none"> <li>LH = 64 LQFP (10 mm x 10 mm)</li> <li>MP = 64 MAPBGA (5 mm x 5 mm)</li> <li>LL = 100 LQFP (14 mm x 14 mm)</li> </ul>

*Table continues on the next page...*

## Part identification

Field	Description	Values
		<ul style="list-style-type: none"><li>• MC = 121 XFBGA (8 mm x 8 mm)</li><li>• DC = 121 XFBGA (8 mm x 8 mm x 0.5 mm)</li></ul>
CC	Maximum CPU frequency (MHz)	<ul style="list-style-type: none"><li>• 5 = 50 MHz</li><li>• 7 = 72 MHz</li><li>• 10 = 100 MHz</li><li>• 12 = 120 MHz</li><li>• 15 = 150 MHz</li></ul>
N	Packaging type	<ul style="list-style-type: none"><li>• R = Tape and reel</li></ul>

## 7.4 Example

This is an example part number:

MK22FN512VDC12

## 7.5 121-pin XFBGA part marking

The 121-pin XFBGA package parts follow the part-marking scheme in the following table.

**Table 49. 121-pin XFBGA part marking**

PK Partnumber	MK Partnumber	PK Part Marking	MK Part Marking
PK22FN512VDC12	MK22FN512VDC12	P22J9VDC	M22J9VDC

## 7.6 64-pin MAPBGA part marking

The 64-pin MAPBGA package parts follow the part-marking scheme in the following table.

**Table 50. 64-pin MAPBGA part marking**

PK Partnumber	MK Partnumber	PK Part Marking	MK Part Marking
PK22FN512VMP12	MK22FN512VMP12	P22J9VMP	M22J9VMP

## 8 Revision History

The following table provides a revision history for this document.

**Table 51. Revision History**

Rev. No.	Date	Substantial Changes
3	5/2014	<ul style="list-style-type: none"> <li>• In "Voltage and current operating ratings" table, updated maximum digital supply current</li> <li>• Updated "Voltage and current operating behaviors" table</li> <li>• Updated "Power mode transition operating behaviors" table</li> <li>• Updated "Power consumption operating behaviors" table</li> <li>• Updated "EMC radiated emissions operating behaviors for 64 MAPBGA package" table</li> <li>• Updated "Thermal attributes" table</li> <li>• Updated "MCG specifications" table</li> <li>• Updated "IRC48M specifications" table</li> <li>• Updated "16-bit ADC operating conditions" table</li> <li>• Updated "Voltage reference electrical specifications" section</li> <li>• Added "64-pin MAPBGA part marking" table</li> </ul>
2	3/2014	Initial public release

**How to Reach Us:**

**Home Page:**

[freescale.com](http://freescale.com)

**Web Support:**

[freescale.com/support](http://freescale.com/support)

Information in this document is provided solely to enable system and software implementers to use Freescale products. There are no express or implied copyright licenses granted hereunder to design or fabricate any integrated circuits based on the information in this document. Freescale reserves the right to make changes without further notice to any products herein.

Freescale makes no warranty, representation, or guarantee regarding the suitability of its products for any particular purpose, nor does Freescale assume any liability arising out of the application or use of any product or circuit, and specifically disclaims any and all liability, including without limitation consequential or incidental damages. "Typical" parameters that may be provided in Freescale data sheets and/or specifications can and do vary in different applications, and actual performance may vary over time. All operating parameters, including "typicals," must be validated for each customer application by customer's technical experts. Freescale does not convey any license under its patent rights nor the rights of others. Freescale sells products pursuant to standard terms and conditions of sale, which can be found at the following address: [freescale.com/SalesTermsandConditions](http://freescale.com/SalesTermsandConditions).

Freescale, the Freescale logo, and Kinetis are trademarks of Freescale Semiconductor, Inc., Reg. U.S. Pat. & Tm. Off. All other product or service names are the property of their respective owners. ARM and Cortex are registered trademarks of ARM Limited (or its subsidiaries) in the EU and/or elsewhere. All rights reserved.

© 2014 Freescale Semiconductor, Inc.

Document Number Document Number  
K22P121M120SF7  
Revision 3 5/2014

