

EBLOCKS[®]

ECIO base board

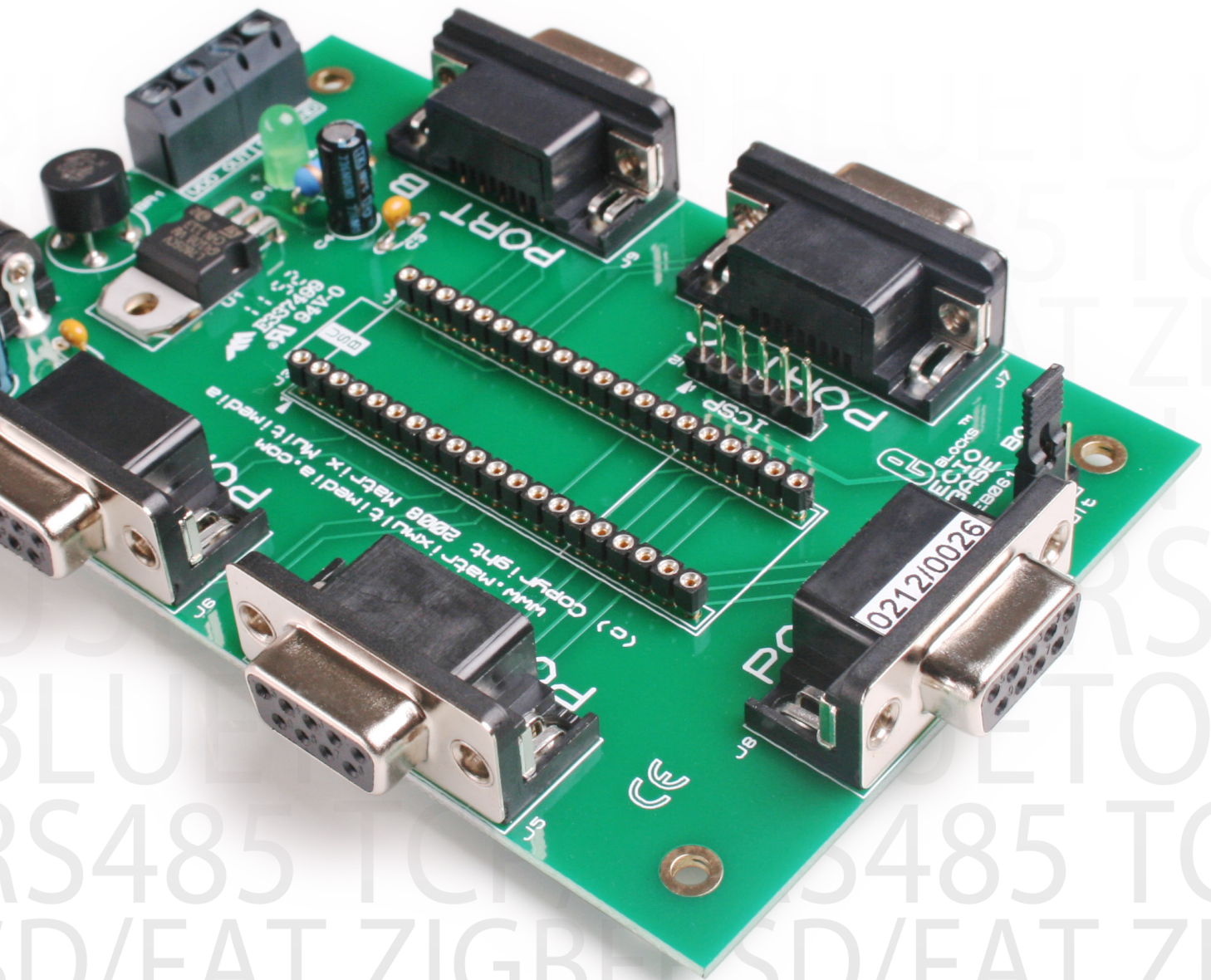

Contents

- About this document 3
- Board layout 3
- General information 4
- Circuit description 4
- Circuit diagram 5

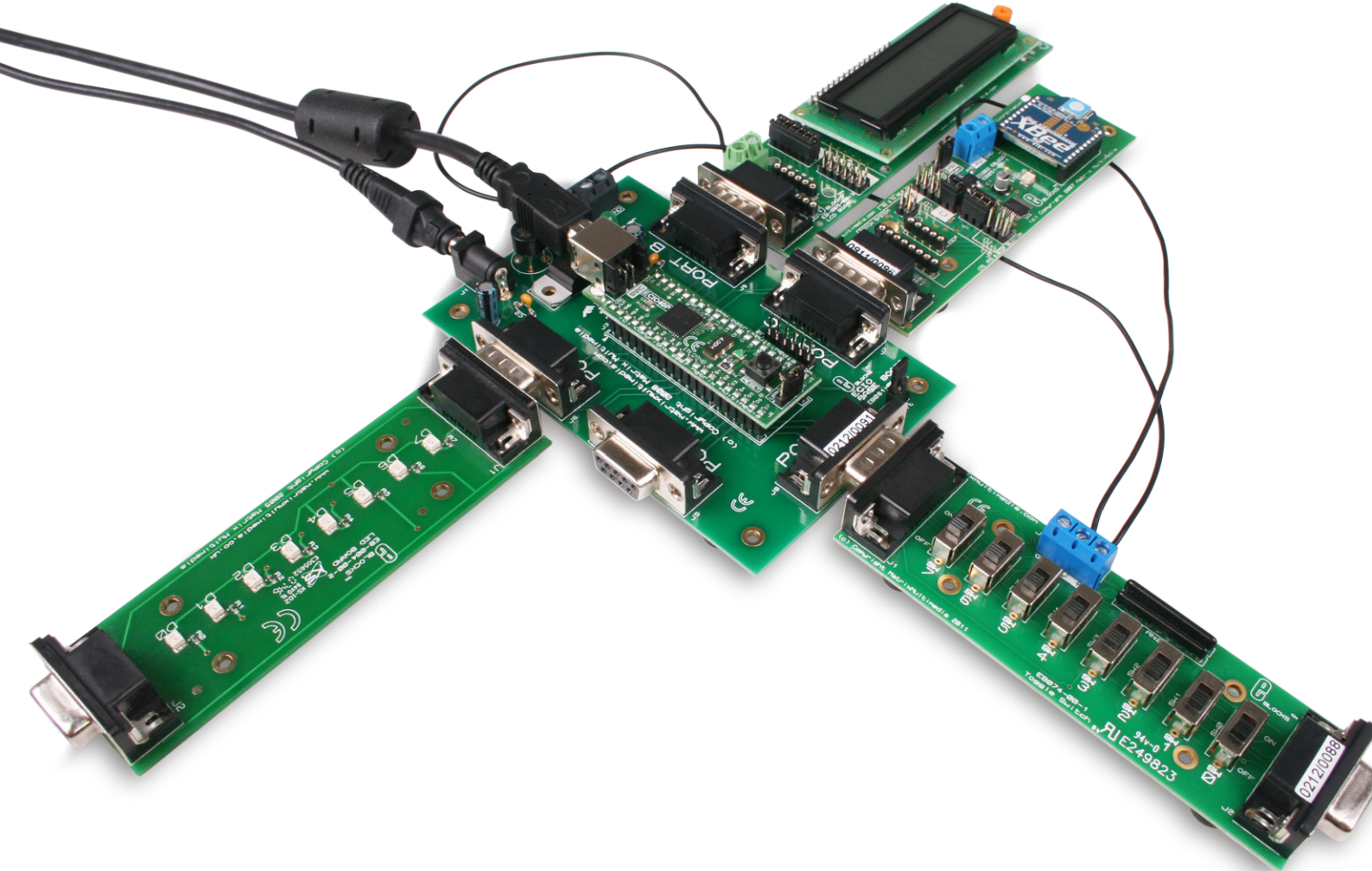

About this document

This document concerns the EB061 ECIO base board.

1. Trademarks and copyright

PIC and PICmicro are registered trademarks of Arizona Microchip Inc. E-blocks is a trademark of Matrix Multimedia Ltd.

2. Disclaimer

The information provided within this document is correct at the time of going to press. Matrix Multimedia reserves the right to change specifications from time to time.

3. Testing this product

It is advisable to test the product upon receiving it to ensure it works correctly. Matrix provides test procedures

for all E-blocks, which can be found in the Support section of the website.

4. Product support

If you require support for this product then please visit the Matrix website, which contains many learning resources for the E-blocks series. On our website you will find:

- How to get started with E-blocks - if you are new to E-blocks and wish to learn how to use them from the beginning there are resources available to help.
- Relevant software and hardware that allow you to use your E-blocks product better.
- Example files and programs.
- Ways to get technical support for your product, either via the forums or by contacting us directly.

Board layout

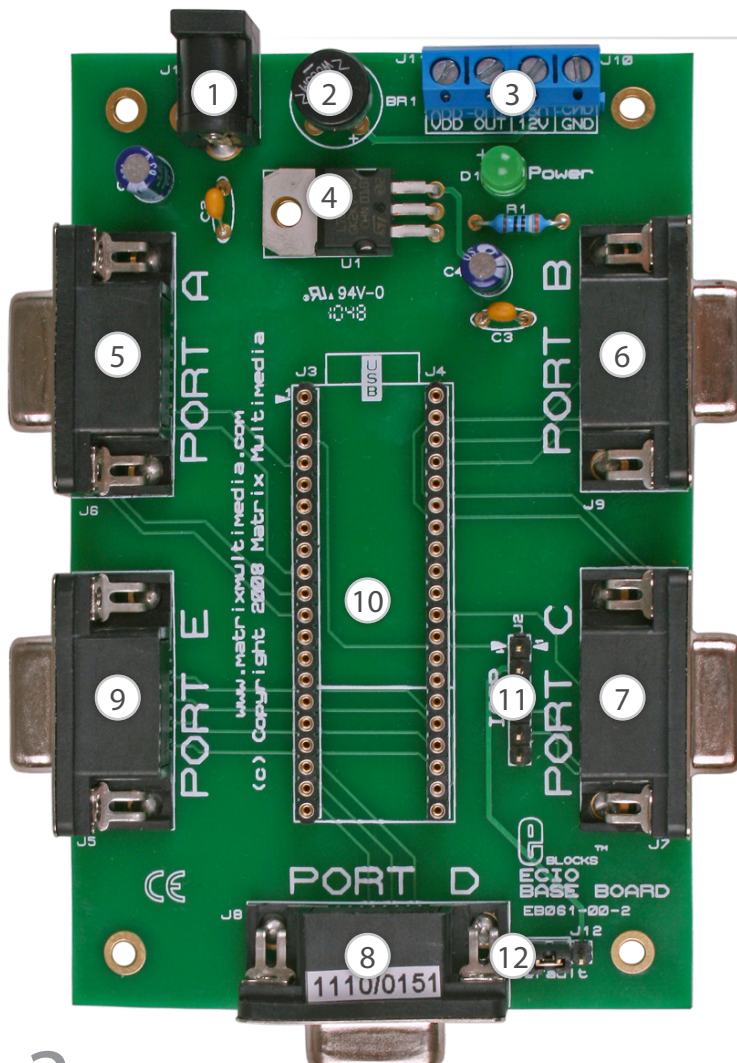

1. External power supply socket
2. Bridge rectifier
3. Output power supply for E-blocks and external hardware
4. 5V voltage regulator
5. E-block connector for Port A
6. E-block connector for Port B
7. E-block connector for Port C
8. E-block connector for Port D
9. E-block connector for Port E
10. ECIO connector socket (ECIO not included)
11. ICSP connector
12. ECIO ARM bootloader recovery jumper

General information

A simple platform for the ECIO to allow connections to standard E-block boards. The board also provides an input for an external power supply as well as a header for in circuit serial programming (ICSP).

1. Features

- E-blocks compatible ports

- External power supply input
- Voltage regulator
- PICkit ICSP interface
- ECIO ARM firmware recovery (TST) jumper

2. Block schematic

Not supplied.

Circuit description

1. Description

The circuit board consists of a means of connecting E-blocks to an ECIO module. The circuit board also allows for a regulated external power supply to be connected as a means of powering the ECIO. The bridge rectifier allows for either polarity to be input from the external power supply. There is also a PICkit compatible ICSP header which allows for the ECIO to be fully reprogrammed.

Warning: If the ICSP connector is used to program the ECIO then the bootloader onboard the ECIO may be corrupted or overwritten. If this occurs then Matrix Multimedia holds no responsibility for the loss of bootloader and will not release or make available the bootloader code.

ECIO ARM warning: When using the ECIO ARM device with the EB061 E-block the TST jumper J12 should be retained in the default position. Moving the TST jumper to the non default position will delete the USB

bootloader loaded into the device and cause the ARM device to reset to factory settings. This can be used to reload the matrix USB bootloader if it becomes damaged or corrupted. See the bootloader reflashing instructions available from the Flowcode ARM installation or the ECIO ARM documentation.

Any ECIO PIC devices that have lost their bootloader can be returned to Matrix Multimedia to be restored but a charge will be incurred.

Contact sales@matrixmultimedia.co.uk for details.

2. 3.3V operation

This board is only compatible with upstream boards operating off 3.3V when the ECIO ARM device is plugged into the E-block. ECIO PIC devices always run at 5V to allow the chip to run fast enough for the USB to work correctly.

Circuit diagram

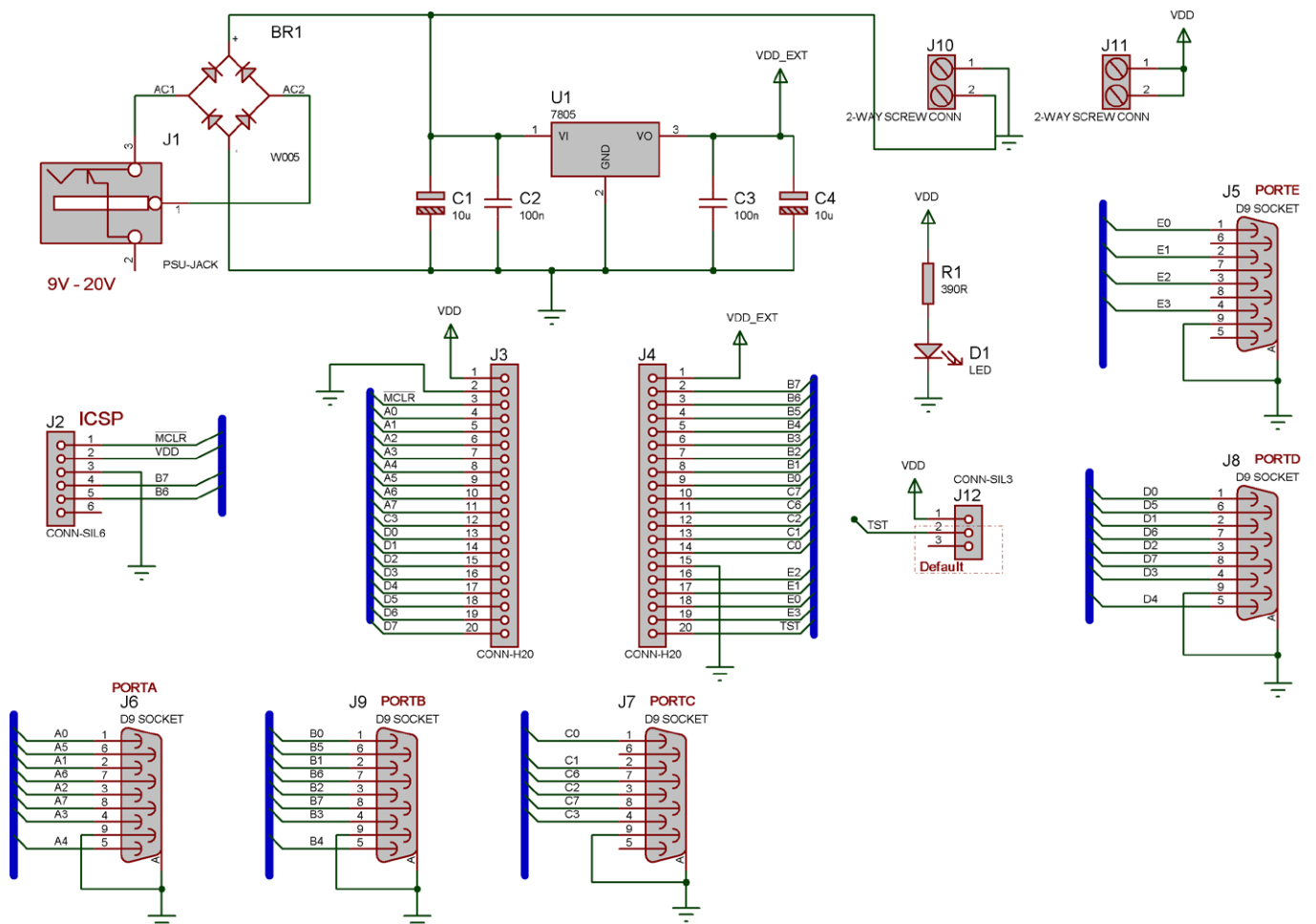



Matrix Ltd.
The Factory
33 Gibbet Street
Halifax, HX1 5BA, UK

t: +44 (0)1422 252380
e: sales@matrixmultimedia.co.uk

www.matrixmultimedia.com

EB061-30-2