

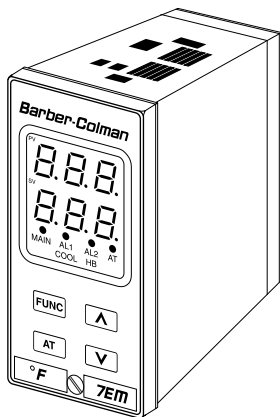

Instruction Manual

1262-IN-009-0-03
February 1998



Model 7EM



A Siebe Group Product

1/8 DIN, THREE DIGIT DISPLAY TEMPERATURE CONTROLLER

MODEL: 0 7 E M - 4 3 1 1 - 0 0 - 0 - 0 0
Field. 1 2 3 4 5 6 7 8 9 10 11 12 13 14 15

Fields 1 through 4. BASE

07EM - Controller

Field 5. INPUT

4 - TC types J, K, L and N; Pt 100, 3 wire RTD
NOTE: All inputs are factory calibrated and
selectable by keys. Factory set at type J.

Field 6. CONTROL ACTION

3 - PID and autotuning (Smart AT)

Field 7. OUTPUT 1

1 - Relay (SPDT) or SSR (jumper selectable)

Field 8. OUTPUT 2 (Cooling/Alarm 1)

1 - Relay (SPDT) or SSR (jumper selectable) or
SSR jumper selectable)

Field 9. OUTPUT 3

0 - None
1 - Alarm 2 (when output 2 configured for alarm 1).
3 - Alarm2, plus Hbd (heater breakdown). Order
transformer separately.

Field 10. POWER SUPPLY

3 - 100 to 240 Vac
5 - 24 Vac/Vdc

Fields 11 through 15. RESERVED

CONGRATULATIONS

Congratulations on your purchase of one of the easiest to configure controllers on the market. After a four step configuration procedure, your process will be up and running.

GUIDE TO SIMPLE SET-UP

Only four steps are required to set-up your controller:

1. Wire the instrument (page 7).
2. Configure the instrument (page 13).
3. Check the operating mode parameters (page 24).
4. Check the autotune (Smart AT) process (page 20).

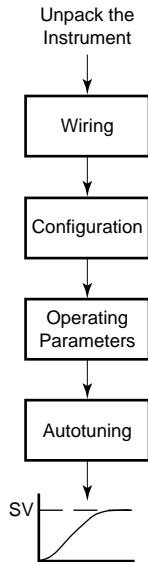

Contents

1/8 DIN, THREE DIGIT DISPLAY TEMPERATURE CONTROLLER	2
MOUNTING REQUIREMENTS	5
DIMENSIONS AND PANEL CUTOUT	6
WIRING GUIDELINES	7
CONFIGURATION PROCEDURE	13
Preliminary Hardware Settings	13
Configuration Key Functions	14
Configuration Procedure	14
Advanced Configuration Procedure	16
OPERATING MODE	17
Operating Key Functions	17
Autotuning (Smart AT) Function	18
Manual Reset of the Alarms	18
Enable/Disable the Control Output	18
Lamp Test	18
OUT 1 Heater Breakdown Alarm	18
Operating Parameters	19
Error Messages	19
Error messages	20
Default Parameters	20
SPECIFICATIONS	23
General	23
Control Actions	23
Inputs	23
Current Transformer Input for OUT 1 Heater Breakdown Detection (Optional)	24
CALIBRATION PROCEDURE	26
Calibration Parameters	26
Procedure	26
Entering Calibration Values	27
MAINTENANCE	30

**CAUTION: USE WIRE SUITABLE
FOR 75 °C MINIMUM**

MOUNTING REQUIREMENTS

Select a mounting location with the following characteristics:

- 1) Low vibration.
- 2) An ambient temperature range between 0 and 50 °C (32 and 122 °F).
- 3) Easy access to the rear of the instrument.
- 4) No corrosive gases (sulfuric gas, ammonia, etc.).
- 5) No water or other fluid (i.e., condensation).
- 6) A relative humidity of 20 to 85% non-condensing.

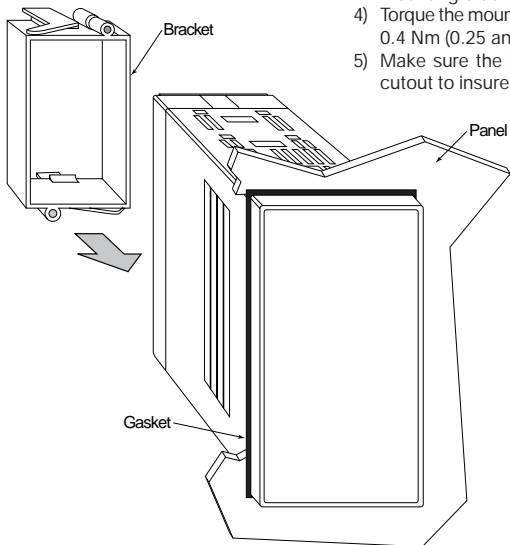

The instrument can be mounted on a panel up to 15 mm (0.591 in) thick with a cutout of 45 x 92 mm (1.772 x 3.622 in) - see outline in "Dimensions and Panel Cutout."

Panel surface texture must be smoother than 6.3 µm.

To assure IP65 and NEMA 4X protection, insert the panel gasket between the instrument and the panel as shown below.

Install the instrument as follows:

- 1) Insert the instrument case in the gasket.
- 2) Insert the instrument in the panel cutout.
- 3) Pushing the instrument against the panel, insert the mounting bracket.
- 4) Torque the mounting bracket screws between 0.3 and 0.4 Nm (0.25 and 0.32 lbin).
- 5) Make sure the instrument will not move within the cutout to insure NEMA 4X/IP65 protection.

DIMENSIONS AND PANEL CUTOUT

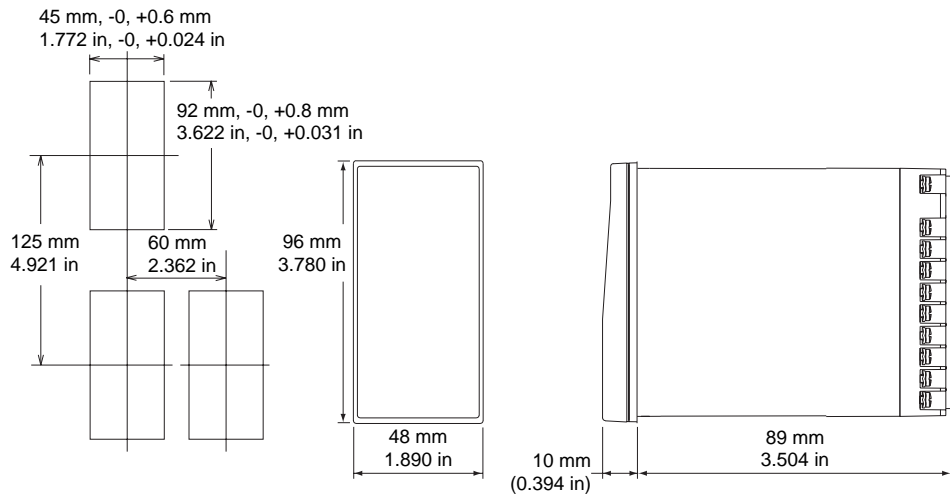

WIRING GUIDELINES

Terminal board

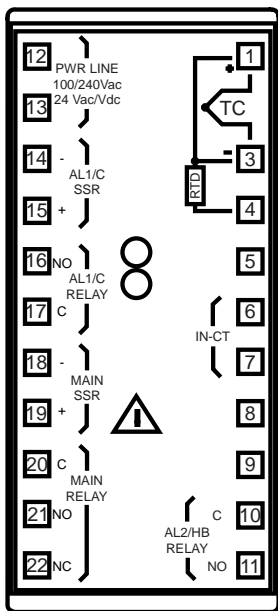

NOTE: Control outputs 1 and 2 are protected by a varistor against an inductive load up to 0.5 Amps. All other outputs, or external contacts in series with the instrument outputs, need an external snubber network (RC) across the terminals:

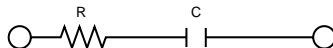

in accordance with the following table:

Load Current	C (μF)	R (Ω)	P (W)	Resistor and Capacitor Voltage
< 40 mA	0.047	100	1/2	260 Vac
< 150 mA	0.1	22	2	260 Vac
< 0.5 Amp	0.33	47	2	260 Vac

A.1) Measuring inputs

Any external components (like zener diodes, etc.) connected between the sensor and input terminals may cause measurement errors (excessive or unbalanced line resistance or possible leakage currents).

TC input

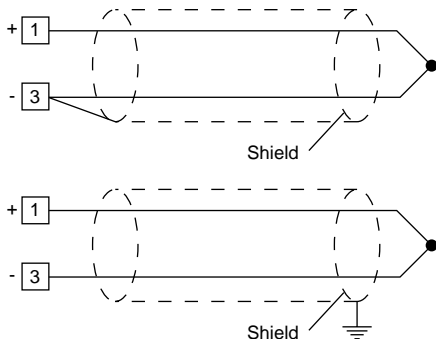

SAFETY NOTE:

- 1) Do not run input wires with power cables.

NOTES:

- 1) For TC wiring use proper compensating cable, preferably shielded.
- 2) Shielded cable should be grounded at one end only.

RTD input

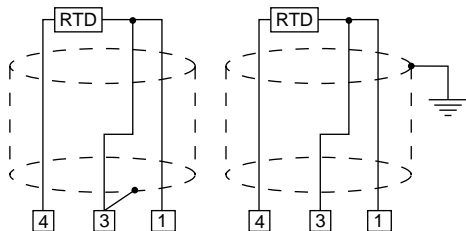

SAFETY NOTE:

- 1) Do not run RTD wires with power cables.

NOTES:

- 1) Ground shielded cable at one end only.
- 2) Use the correct size copper wires.
- 3) The resistance of the 3 wires must be the same.
- 4) Pay attention to line resistance: high line resistance (higher than 20 Ω /wire) can cause measurement errors.

Any external components (like zener diodes, etc.) connected between the sensor and input terminals may cause measurement errors (excessive or unbalanced line resistance or possible leakage currents).

Thermocouple compensating cable color codes.

Thermocouple Material	British BS 1843	American ANSI MC 96.1	German DIN 43710	French NFE 18-001
T Copper Constantan	+ White - Blue Blue	+ Blue - Red Blue	+ Red - Brown Brown	+ Yellow - Blue Blue
J/L Iron Constantan	+ Yellow - Blue Black	+ White - Red Black	+ Red - Blue Blue	+ Yellow - Black Black
K Nickel Chromium Nickel Aluminum	+ Brown - Blue Red	+ Yellow - Red Yellow	+ Red - Green Green	+ Yellow - Purple Yellow
R Platinum/Platinum 13% Rhodium	+ White - Blue Green	+ Black - Red Green	+ Red - White White	+ White - Green Green
S Platinum/Platinum 10% Rhodium	+ White - Blue Green	+ Black - Red Green	+ Red - White White	+ White - Green Green
E Chromel Constantan	+ Brown - Blue Brown	+ Violet - Red Violet	- - -	- - -
B Platinum 30% Rh Platinum 6% Rh	- - -	+ Grey - Red Grey	- - -	- - -
N Nicrosil/Nisil	-	-	-	-

A.2) Current transformer input

SAFETY NOTE:

- 1) Do not run current transformer input wiring with AC power cables.

NOTE:

- 1) The minimum active period to perform this measurement is 50 ms.
- 2) The input impedance is 10 Ω .
- 3) The maximum input current is 50 mA.

This input measures the current used by OUT 1.

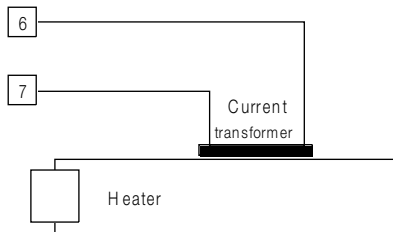

B.1) Relay outputs

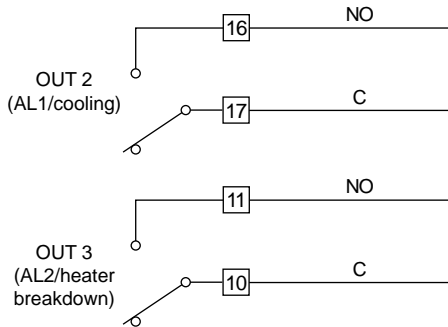
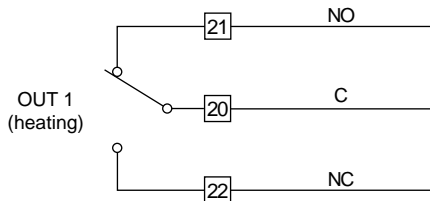

OUT1: Contact rating of 3 Amps/250 Vac resistive load.

OUT2: Contact rating of 2 Amps/250 Vac resistive load.

OUT3: Contact rating of 2 Amps/250 Vac resistive load.

The output 2 and the NO contact of the output 1 are protected by varistor from inductive load with an inductive component up to 0.5 A. The number of operations is 1 x 10⁵ at specified rating.

Notes:

- 1) To avoid electric shock, connect power line at the end of wiring procedure.
- 2) For power connections, use no. 16 AWG or larger wires rated for at least 75°C.
- 3) Use copper conductors only.
- 4) Don't run input wires together with power cables.
- 5) Relay output and SSR driver output are both available. When a relay output is desired, it is necessary to enable the relay output, and viceversa. See "Preliminary Hardware Settings."

B.2) Inductive loads

High voltage transients can occur when switching inductive loads. It is recommended to install an additional RC network across the internal contacts as shown.

The same problem can occur when a switch is used in series with the internal contacts.

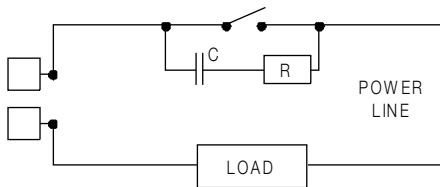

It is recommended to install an additional RC network across the external contacts as close to the instrument terminals as possible.

The value of capacitor (C) and resistor (R) are shown in the following table.

Load	C (μF)	R (Ω)	P (W)	Resistor and Capacitor
<40 mA	0.047	100	1/2	260 Vac
<150 mA	0.1	22	2	260 Vac
<0.5 Amp	0.33	47	2	260 Vac
<1 Amp	0.47	47	2	260 Vac

Relay output wiring must be as far away as possible from input wiring and communication cables.

B.3) Voltage outputs for SSR drive

These are time proportioning outputs.

Logic voltage for SSR drive.

Logic status 1: 24 Vdc \pm 20% @ 1 mA.

14 Vdc \pm 20% @ 20mA.

Logic status 0: Less than 0.5 Vdc.

NOTES:

- 1) This output is not isolated. A double or reinforced isolation between the instrument output and the power supply must be made by an external solid state relay.
- 2) Relay or SSR output must be configured using jumpers J304 and J305 as shown in the "preliminary hardware settings."

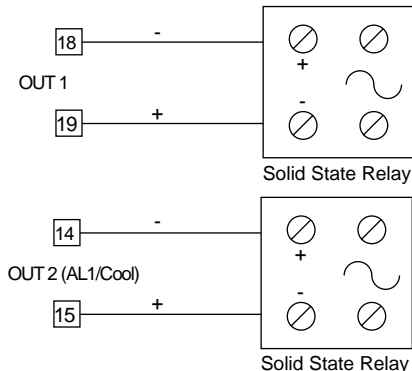

F) Power line wiring

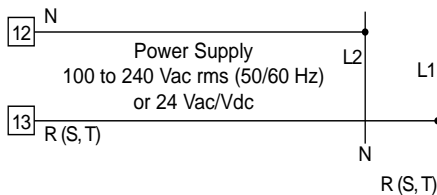

SAFETY NOTES:

- 1) Do not run input wires with power cables.
- 2) Permanently connected equipment must include a switch or circuit-breaker in the installation. Place it in close proximity to the equipment and within easy reach of the operator. Mark it as the disconnecting device for the equipment.
A single switch or circuit-breaker can drive more than one instrument.
- 3) To avoid shock and possible instrument damage, connect power last.
- 4) Before connecting the power line, check that the voltage is correct (see Model Number).
- 5) When the NEUTRAL line is present, connect it to terminal 12

NOTES:

- 1) For supply connections use 16 AWG or larger wires rated for at least 75 °C.
- 2) Use copper conductors only.
- 3) Before connecting the power line, check that the voltage is correct.
- 4) Polarity does not matter for 24 Vdc wiring

The instrument power supply is not fuse protected. Please provide a fuse T Type, 1 A, 250 V when fuse is broken. It is advisable to verify the power supply circuit, so that it is necessary to send the instrument back to your supplier

CONFIGURATION PROCEDURE

Preliminary Hardware Settings

- 1) Remove the instrument from its case.
- 2) Set J303, J304 and J305 as shown below:

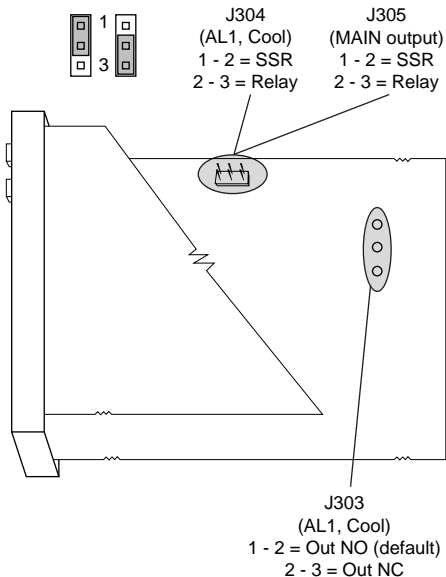

NOTE: J303 is a solder jumper and is on the component side of the PCB.

Figure 1

Open input circuit

This instrument is able to identify an open circuit for TC and RTD inputs. The open input circuit condition for RTD input is shown by an "overrange" indication. For TC input, either an overrange indication (standard) or underrange indication can be selected from the following table:

SH2	CH2	Indication
open	close	overrange (default)
close	open	underrange

Both pads are located on the solder side of the CPU card.

CAUTION: Solder carefully to avoid damage to PCB or other components.

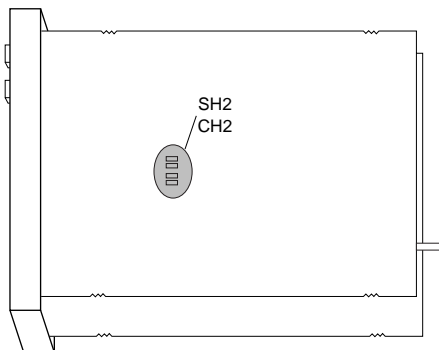

Configuration Key Functions

FUNC = The new setting of the selected parameter is stored and the next parameter is displayed (in increasing order).

MAN = Scrolls back through the parameters without storing the new setting.

▲ = Increases the setting of the selected parameter.

▼ = Decreases the setting of the selected parameter.

Configuration Procedure

- 1) Switch off power to the instrument.
- 2) Remove the instrument from its case.
- 3) Open switch V2, located 2 inches behind the lower left corner of the display (see Figure 2).
- 4) Re-insert the instrument in its case.
- 5) Switch on power to the instrument.
NOTE: If instrument displays "CAL", press the ▲ key to select the configuration procedure "CnF".
- 6) Press the FUNC key.

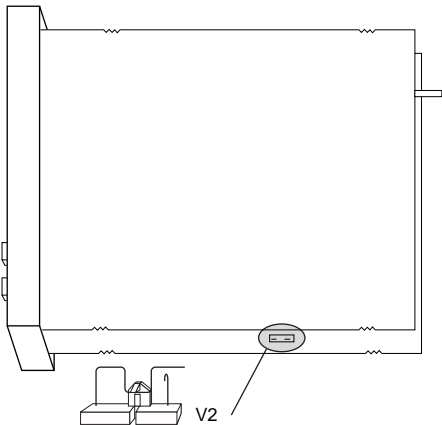

P1	Input type and standard range
0	= TC type L range 0 to +800.0 °C
1	= TC type J range 0 to +800 °C
2	= TC type K range 0 to +999 °C
3	= TC type N range 0 to +999 °C
4	= RTD type Pt 100 range -199 to +500 °C
5	= RTD type Pt 100 range -19.9 to +99.9 °C
6	= TC type T range 0 to +400 °C
8	= TC type L range 0 to +999 °F
9	= TC type J range 0 to +999 °F
10	= TC type K range 0 to +999 °F
11	= TC type N range 0 to +999 °F
12	= RTD type Pt 100 range -199 to +999 °F
13	= RTD type T range 0 to +752 °F

P2 Initial scale value

Not available when P1 = 5.

The initial and full scale values are used by the PID algorithm to calculate the input span.

P3 Full scale value

Not available when P1 = 5.

The initial and full scale values are used by the PID algorithm to calculate the input span.

NOTE: The minimum input span (P3 - P2) for:

TC = 300 °C or 600 °F

RTD = 100 °C or 200 °F.

P4 Output configuration

H = Heating.

HC = Heating/Cooling.

P5 Heating output type

rEL = Relay.

SSr = SSR.

(J305 must correspond).

P6 Cooling element
Available only when P4= HC.
Air = Air.
OIL = Oil.
H2O = Water.

P7 Alarm 1
Available only when P4 = H.
0 = Not provided.
1 = Process alarm.
2 = Band alarm.
3 = Deviation alarm.

P8 Alarm 1 operating mode
Not available when P7 = 0 or P4 = HC.
H.A = High alarm (outside band) with automatic reset.
L.A = Low alarm (inside band) with automatic reset.
H.L = High alarm (outside band) with manual reset.
L.L = Low alarm (inside band) with manual reset.

P9 Alarm 1 standby
Not available when P7 = 0 and P4 = HC.
OFF = Standby disabled.
ON = Standby enabled.
NOTE: Standby allows you to disable the alarm after a setpoint modification or at instrument startup.
The alarm is automatically turned on when the process variable reaches setpoint.

P10 Alarm 2
0 = Not provided.
1 = Process alarm.
2 = Band alarm.
3 = Deviation alarm.
Alarm 2 and HBD function are in "or" condition on the output 3.

P11 Alarm 2 operating mode and reset of HBD alarm
Not available when P10 = 0 and P16 = OFF.
H.A = High alarm (outside band) with automatic reset.
L.A = Low alarm (inside band) with automatic reset.
H.L = High alarm (outside band) with manual reset.
L.L = Low alarm (inside band) with manual reset.
Note: The HBD alarm is a low alarm, but it assumes the same reset type selected for alarm 2.

P12 Alarm 2 standby
ON = Standby enabled.

P13 Type of OFFSET applied on measure value
If P13 = 0 - Then a constant OFFSET (P14) is applied over the entire range.
If P13 is not = 0 - Then P13 is the point at which P14 is applied. P14 is the distance between the real curve and the adjusted curve at P13. Both the real curve and the adjusted curve pass through 0, 0.

P14 OFFSET value
If P13 = 0 - P14 can be set with keys, in engineering units, from -20 to +20% of the input range.
If P13 is not = 0 - P14 can be set with keys, in engineering units, from -20 to +20% of P13

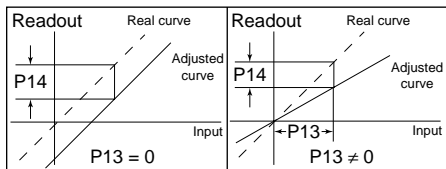

P15 Setpoint for the “soft start” function
 Setpoint, in engineering units, of the “Soft start” function (output power limiting). At instrument start up, if the measured value is lower than the programmed setpoint, the instrument will automatically enable the output limiter (see OLH parameter), and it maintains this limit for a time programmed by tOL parameter. At instrument start up, if tOL parameter is equal to InF, the P15 setting has no effect.

P16 Current measurement

- OFF = Current measurement disabled.
 n.O. = Current will be measured during the ON period (logic status 1 for SSR or contact NO for relay output).
 n.C. = Current will be measured during the OFF period (logic status 0 for SSR or contact NC for relay output).

P17 Current transformer range

Available only when P16 is different from off.

- 10 = 10 Amps (resolution 0.1 A)
 25 = 25 Amps (resolution 1 A)
 50 = 50 Amps (resolution 1 A)
 100 = 100 Amps (resolution 1 A)

P18 Safety lock

- 0 = Safety lock is always disabled.
 1 = Safety lock is always enabled.
 2 to 499 = SP can be modified. This numeric password is used to access the other modifiable parameters.
 500 to 999 = SP, A1 and A2 can be modified. This numeric password is used to access the other modifiable parameters.

The configuration procedure is now complete. The instrument should show “-.-.-” on both displays. Press the FUNC key; the instrument will return to the beginning

of the configuration procedure. To continue with controller set-up go to the operating mode found in the next section. To access the advanced configuration parameters proceed as follows:

- 1) Use the ▲ and ▼ keys to enter 217 on the display.
- 2) Press the FUNC key.

Advanced Configuration Procedure

P19 Main output

Available only when P4 = H.

- r = Reverse (heating).
 d = Direct (cooling).

NOTE: When P4 = Hc, P19 parameter is equal to “r”

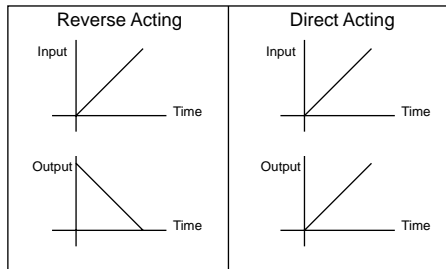

P21 Action of the alarm 1 relay

Available only when P7 is different from 0 and P4 = H

- r = Reverse action (relay de-energized in alarm condition).
 d = Direct action (relay energized in alarm condition).

P22 Action of alarm 2 relay

Available only when P10 is different from 0 and P16 is not • OFF.

- r = Reverse action (relay de-energized in alarm condition).
 d = Direct action (relay energized in alarm condition).

P23 Automatic modification of "relative cooling gain"
Available only when P4 = HC.

OFF = Autotuning (Smart AT) does not modify
"relative cooling gain."

ON = Autotuning modifies "relative cooling gain."

P24 Output maximum rate of change

Sets the maximum rate of change of the power output.
P24 is programmable from 1 to 10% of the control output.
When over 10%, the upper display is blank and the rate
of change has no limit.

P25 Parameter display parameters

Available when P18 is different from 0.

OFF = Protected parameters are not displayed.

ON = Parameters are always displayed.

P26 Autotuning (Smart AT) enable/disable

0 = Autotuning disabled.

1 = Autotuning enabling/disabling is not
protected by safety lock.

2 = Autotuning enabling/disabling is protected by
safety lock.

P27 Maximum value of the proportional band set by
autotuning

Available only when P26 is different from 0.

Can be programmed from P28 or P29 value to 99.9.

P28 Minimum value of the proportional band set by
autotuning in heating control only

Available only when P26 is different from 0 and P4 = H.
Can be programmed from 1.0% to P27 value.

P29 Minimum value of the proportional band set by
autotuning in heating/cooling control only

Available only when P26 is different from 0 and P4 = HC.
Can be programmed from 1.5% to P27 value.

P30 Minimum value of integral time settable by
autotuning

Available only when P26 is different from 0.

Programmable from 00.1 (10 seconds) to 02.0 (2 minutes).

P31 Extension of the anti-reset windup

Range from -30 to +30% of the proportional band.

NOTE: A positive value increases the high limit of the
anti-reset windup (over setpoint) while a
negative value decreases the low limit of the
anti-reset windup (under setpoint).

This completes the configuration procedure. The display
should show "COnF". Close switch V2, see configuration
procedure Figure 2.

OPERATING MODE

- 1) Remove the instrument from its case.
- 2) Close switch V2 (see configuration procedure Figure 2).
- 3) Re-insert the instrument in its case.
- 4) Switch on the instrument. Operating Key Functions

FUNC = The new setting of the selected parameter
is stored and the next parameter is
displayed (in increasing order).

AT = Enable/disable the autotuning (Smart AT)
function (hold for two seconds).

▲ = Increases the setting of the selected parameter
or displays the heating load current.

▼ = Decreases the setting of the selected
parameter.

NOTE: There is a 10 second time-out for parameter
modification. If no keys are pressed during this
time period, the instrument automatically goes
to the "normal display mode" and the last
parameter is not changed.

Autotuning (Smart AT) Function

Autotuning is automatically optimizes the control action.

To enable autotuning, press the AT key for more than 1.5 seconds. The autotuning LED will light or flash according to the algorithm selected. When autotuning is enabled, it is possible to display but not modify the control parameters (PB, TI, TD. For rC, see P23). Press the AT key for more than 1.5 seconds to disable autotuning and return to the normal (PID) control mode. Once autotuning is turned off, the instrument maintains the calculated control parameters, but allows the parameters to be modified.

NOTES:

- 1) When ON/OFF control is programmed (PB = 0), autotuning is disabled.
- 2) Autotune enable/disable can be protected by the safety lock password (see P26 in the Configuration Procedure).

Setpoint Access

When the device is in the AUTO mode and the “normal display mode,” the setpoint can be directly accessed and modified.

- 1) Press the ▲ or ▼ key (and hold for 3 seconds); the setpoint will start to change.
- 2) Once the desired setting is reached, wait 3 seconds before pressing a key and the new setpoint will be used.

Manual Reset of the Alarms

If the alarm has been configured as a latched alarm, the alarm status will persist after the alarm condition has disappeared.

To reset the alarm, press the FUNC key to select the “n.rS” parameter (the display will show “n.rS” and “OFF.” Use the ▲ and ▼ keys to select “ON” and press the FUNC key again.

The alarm reset action will only be successful if the alarm condition has disappeared.

Enable/Disable the Control Output

With the instrument in the “normal display mode,” press and hold (for 5 seconds) the ▲ key and the FUNC key to disable the control outputs. The device will function as an indicator. All control outputs will be off and the word “OFF” will be appear on the lower display. Alarms will be in a non-alarm condition.

Press and hold (for 5 seconds) the ▲ key and the FUNC key a second time to restore the control status. If the alarm standby has been configured, alarms will respond as though it were a powerup condition.

Lamp Test

Pressing the ▼ + FUNC keys initiates a Lamp Test. All display segments and LED’s will light with a 50% duty cycle. No timeout is applied to a lamp test. Pressing the ▼ + FUNC keys returns the instrument to the “normal display mode.”

OUT 1 Heater Breakdown Alarm

The instrument measures the OUT 1 current and generates an alarm if the current is lower than the “Hbd” setpoint. A fault condition is shown by the “AL2/HB” LED flashing and by the “AL2/HB” relay status. Press the ▲ key to display the current. The lower display will show the current in engineering units (a 2 digit number followed by the letter “A.” The▲ key will return the instrument to the “normal display mode.”

The load current is sampled only if the power output has been applied to the load for a minimum time of 50 ms. If no load current measurements are going to be performed for one cycle (CY1), the displayed current value will start to flash. In configuration, parameter P16 is used to select the type of contact (N.O. or N.C.) used to drive the load.

Operating Parameters

From the “normal operating mode,” press the FUNC key. The lower display will show the code while the upper display shows the setting or the status (ON or OFF) of the selected parameter.

Press the ▲ or ▼ key to change the setting.

Press the FUNC key again and the instrument stores the new setting and goes to the next parameter.

Some of the following parameters may not appear, depending on the configuration.

Param	Description
SP	Main setpoint. Range rL to rH.
n.rS	Manual reset of alarms. Available only when one alarm with manual reset has been programmed. Set ON, and push the FUNC key to reset the alarms.
nnn	Software key for parameter protection. This parameter is skipped if P18 = 0 or 1. The instrument shows the safety key status: ON = instrument is in LOCK condition; OFF = instrument is in UNLOCK condition. To switch from LOCK to UNLOCK condition, set a value equal to P18 parameter. To switch from UNLOCK to LOCK condition, set a value different from P18 parameter.
A1	Alarm 1 setpoint value. This parameter is present if alarm 1 is configured only. Ranges: • P2 to P3 for process alarm • 0 to 500 units for band alarm • -199 to 500 units for deviation alarm.
A2	Alarm 2 setpoint value. For other details see A1 parameter.
H1	Alarm 1 hysteresis. This parameter is present if alarm 1 is configured only. Range from 0.1% to 10.0% of the input span or 1 LSD.

Note: if the hysteresis of a band alarm is larger than the alarm band, the instrument will use a hysteresis value equal to the programmed band minus 1 digit.

H2 Alarm 2 hysteresis. For other details see H1 parameter.

Pb Proportional band. Ranges:
• 1.0% to 99.9% of span for heating output
• 1.5% to 99.9% of span for heating/cooling output

When Pb parameter is set to 0, the instrument performs an on-off control: the ti, td, IP, C, C2, rC, OLP, OLH and tOL parameters are skipped, and SMART AT function is disabled. Note: when SMART AT is enabled, the Pb parameter range is limited by P27, P28 and P29 parameters.

HS Hysteresis for on-off control action. Available only when Pb=0. Range from 0.1% to 10.0% of the input span.

ti Integral time. This parameter is skipped if Pb = 0 (on-off action). Range from 00.1 to 20.0 (mm.s). Above this value the display blanks and integral action is excluded. When SMART AT is enabled, the minimum value of the integral time is limited by P30 parameter.
td Derivative time. This parameter is skipped if Pb = 0 (on-off action). Range from 0.01 to 9.59 (m.ss). Setting the 0 value the derivative action is excluded. When SMART AT is enabled, the derivative time value will be equal to 1/4 of the integral time.

IP Integral pre-load. This parameter is skipped if Pb = 0 (on-off action). Ranges:
• 0 to 100% when P4 = H
• -100 to 100% when P4 = HC

C Output 1 cycle time. Available if Pb parameters is different from 0 only. Range from 1 to 200 s.

C2	Output 2 cycle time. Available only if P4 = HC and Pb is different from 0 only. Range from 1 to 200 s.
rC	Relative cooling gain. This parameter is skipped if Pb = 0 (on-off action) or P4 = H. Range from 0.20 to 1.00. When SMART AT function is enabled, the rC parameter is limited in accordance to the selected coolant: <ul style="list-style-type: none"> • 0.85 to 1.00 when P6 = Air • 0.80 to 0.90 when P6 = OIL • 0.30 TO 0.60 when P6 = H2O
OLP	Deadband/overlap between H/C outputs. OLP is skipped if Pb = 0 (on-off action) or P4 = H. A negative OLP value shows a deadband while a positive value shows an overlap. Range from -20 to 50.
rL	Setpoint low limit. Range from minimum range value (P2) to rH. When P2 has been modified, rL will be realigned to it.
rH	Setpoint high limit. Range from rL to full scale value (P3). When P3 has been modified, rH will be realigned to it.
rP	Ramp applied to the setpoint changes. Range from 1 to 100 digit/min. Above this value the display shows "Inf" and the transfer will be a step transfer.
OLH	Control output high limit. Skipped if Pb = 0 (on-off action) Range: <ul style="list-style-type: none"> • 0 to 100% when P4 = H • -100 to 100% when P4 = HC.
tOL	Time duration of the output power limiter. tOL is skipped if Pb = 0 (on-off action). Range from 1 to 100 min. Above this value the display shows "Inf" and the limit will be ever enabled. The tOL can be modified but the new value will become operative only at the next instrument start up.
Hbd	Setpoint of heater breakdown alwrm. Hbd is available only when P16 is different from OFF. Range within the current transformer range (see P17).

Error Messages

Overrange or underrange and sensor break indications
This device is capable of detecting process variable faults (OVERRANGE, UNDERRANGE or SENSOR BREAK). An OVERRANGE condition will appear as:

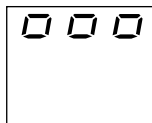

An UNDERRANGE condition will appear as:

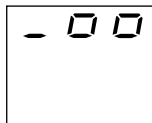

A sensor break will be signalled as:

- For TC input: OVERRANGE or UNDERRANGE (selected by a solder jumper)
- For RTD input: OVERRANGE

Sensor lead short circuit detection:

- On RTD input, a special test is provided to signal OVERRANGE when input resistance is less than 15 Ohms (short circuit sensor detection).

Output action on Over/Underrange:

- The instrument is set for one output and an OVERRANGE is detected, then OUT 1 turns OFF (if reverse acting) or ON (if direct acting).
- Instrument is set for heating/cooling and an OVERRANGE is detected, then OUT 1 turns OFF and OUT 2 turns ON.
- The instrument is set for one output only and an UNDERRANGE is detected, then OUT 1 turns ON (if reverse acting) or OFF (if direct acting).

- The instrument is set for heating/cooling and an UNDERRANGE is detected, then OUT 1 turns ON and OUT 2 turns OFF.

Error messages

On powerup, the instrument performs a self-diagnostic test. When an error is detected, the lower display shows an "Err" indication while the upper display shows the code of the detected error.

Error list

100	EEPROM write error.
150	CPU error.
200	Attempt to write to protected memory.
201 - 2xx	Configuration parameter error. The two least significant digits show the number of the wrong parameter (ex. 209 Err indicates an Error in parameter P9).
301	RTD input calibration error.
305	TC input calibration error.
307	RJ input calibration error.
310	CT input calibration error.
400	Control parameter error.
500	Auto-zero error.
502	RJ error.
510	General error during calibration procedure.

Dealing with error messages

- 1) When a configuration parameter error is detected, repeat the configuration procedure of that specific parameter.
- 2) If an error 400 is detected, simultaneously press the ▲ and ▼ keys (see Loading default operating parameters) to load the default parameters and then repeat the control parameter setup.
- 3) For all other errors, contact your Service Representative.

Default Parameters

Loading default operating parameters

The control parameters can be loaded with predetermined default values. These are the settings loaded into the instrument prior to shipment from the factory. To load the default values proceed as follows:

- a) Close switch V2 (see configuration procedure Figure 2).
- b) Autotuning (Smart AT) must be disabled.
- c) Hold down the ▼ key and press the ▲ key; the display will show:



- e) Within 10 seconds press the ▲ key; the display will show:

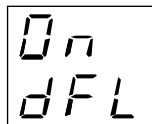

- g) Press the FUNC key; the display will show:

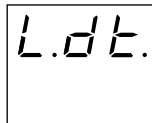

This indicates that the loading procedure has been initiated. After about 3 seconds the loading procedure is complete and the instrument reverts to the "normal display mode." The following is a list of the default operating parameters loaded during the procedure:

Default operating parameter list

Param	Default Value
SP	Minimum of range
nnn	OFF
n.rS	OFF
A1, A2	Minimum of range (process alarms) 0 (deviation or band alarms)
H1, H2	0.1% of span
PB	4.0%
HS	0.5%
tl	4.0 (4 minutes)
td	1.0 (1 minute)
IP	30% for 1 control output 0% for 2 control outputs
C	20 seconds (relay output) 2 seconds (SSR output)
C2	10 seconds for P6 = Alr 4 seconds for P6 = OIL 2 seconds for P6 = H2O
rC	1.00 for P6 = Alr 0.80 for P6 = OIL 0.40 for P6 = H2O
OLP	0
rL	Initial scale value
rH	Full Scale value
rP	Infinite (step transfer), blank screen
OLH	100%
tOL	Infinite
Hbd	50% of the full scale

Default Configuration Parameters

The configuration parameters can be loaded with predetermined default values. These are the settings loaded into the instrument prior to shipment from the factory. To load the default values proceed as follows:

- Open switch V2 (see configuration procedure Figure 2).
- The upper display will show:

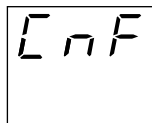

- Press the ▼ key; the lower display will show the firmware version.

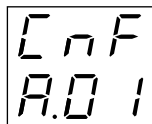

- Still holding the ▼ key, press the ▲ key. The display will show:

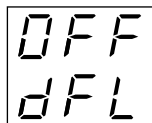

e) Use the ▲ key to select table 1 (European) or table 2 (American) default parameters; the display will show:

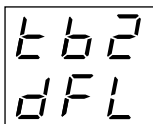

g) Press the FUNC key; the display will show:

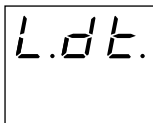

This indicates that the loading procedure has been initiated. After about 3 seconds the loading procedure is complete and the instrument reverts to the “COnF” display. The following table is a list of the default configuration parameters loaded during the procedure:

Default configuration parameter list:

Parameter	Table 1	Table 2
	European	USA
P1	1	9
P2	0°C	0°F
P3	400°V	999°F
P4	H	H
P5	rEL	rEL
P6	Air	Air
P7	1	1
P8	HA	HA
P9	OFF	OFF
P10	0	0
P11	HA	HA
P12	OFF	OFF
P13	0	0
P14	0	0
P15	0	0
P16	OFF	OFF
P17	10 Amps	10 Amps
P18	0	0
P19	rEV	rEV
P21	diR	diR
P22	diR	diR
P23	OFF	OFF
P24	10%/s	10%/s
P25	ON	ON
P26	2	2
P27	30%	30%
P28	1.0%	1.0%
P29	1.5%	1.5%
P30	00.3	00.3
P31	10	10

SPECIFICATIONS

General

Case: Dark grey polycarbonate. Self-extinguishing degree V-0 according to UL94.

Front Protection: Designed and tested for IP65 and NEMA 4X.

Installation: Panel mounting by means of brackets.

Rear Terminal Block: 21 screw terminals with safety rear cover.

Dimensions: 48 x 96mm (1.890 x 3.870 in.) according to DIN 43700; 89mm (3.504 in.) depth.

Cutout: 45 mm -0 mm, +0.6 mm x 92 mm, -0, +0.8 mm (1.772 in -0 in, +0.024 x 3.662 in, -0 +0.031 in)

Weight: 600 grams max. (1.6 lbs.).

Power Supply (Switching Mode):
100 to 240 Vac. 50/60 Hz (+10 to -15% of the nominal value) or 24 Vac/Vdc ($\pm 10\%$ of the nominal value).

Power Consumption: 6 VA.

Insulation Resistance: Greater than 100 M Ω according to IEC 1010-1.

Isolation Voltage: 1500 Vrms according to IEC 1010-1.

D/A Conversion: Dual slope integration.

Electromagnetic Compatibility and Safety Requirements:
This instrument is marked CE. Therefore, it is conforming to council directives 89/336/EEC (reference harmonized standard EN50081-2 and EN50082-2) and to council directive 73/23/EEC and 93/68/EEC (reference harmonized standard EN61010-1).

Installation Category: II

Temperature Drift: <200 ppm/ $^{\circ}$ C (RJ excluded) <400 ppm/ $^{\circ}$ C for RTD input with -19.9/99.9 $^{\circ}$ C range.

Sampling Time: 500 ms.

Resolution: 30000 counts.

Accuracy: $\pm 0.2\%$ full scale span or $\pm 1^{\circ}$ C, @ 25 $^{\circ}$ C and nominal power supply voltage.

Common Mode Rejection Ratio: 120 dB @ 50/60 Hz.

Normal Mode Rejection Ratio: 60 dB @ 50/60 Hz.

Operating Temperature: 0 to 50 $^{\circ}$ C.

Storage Temperature: -20 to 70 $^{\circ}$ C.

Humidity: From 20 to 85% RH non-condensing.

Protection: 1) Watch dog for automatic reset; 2) DIP switches for configuration and calibration parameter protection.

Control Actions

On/off, PID or autotuning (Smart AT)

Special Function: Standby alarm sequence.

Inputs

Thermocouples Type: J, K, L, N and T or RTD Pt 100, keyboard configurable.

Engineering Units: $^{\circ}$ C and $^{\circ}$ F keyboard configurable.

Reference Junction: Automatic compensation for ambient temperature between 0 and 50 $^{\circ}$ C.

Sensor Lead Impedance: 100 Ω maximum for TC input.

RTD Line Resistance: Automatic compensation up to 20 Ω /wire.

Reference Junction Drift: 0.1 $^{\circ}$ C/ $^{\circ}$ C.

Input Impedance: Greater than 1 M Ω .

Sensor Break: Downscale or upscale programmable.

On RTD inputs, an OVERRANGE is indicated when input resistance is less than 15 Ω (short circuit sensor detection.)

Calibration: According to IEC 584-1 and DIN 43710-1977.

Input	Standard Ranges		
	$^{\circ}$ C	$^{\circ}$ F	
L	0 to 800	0 to 999	DIN 43710-1977
J	0 to 800	0 to 999	IEC 584-1
K	0 to 999	0 to 999	IEC 584-1
N	0 to 999	0 to 999	IEC 584-1
Pt100	-19.9 to 99.9		DIN 43760
Pt100	-199 to 500	-199 to 999	DIN 43760
T	0 to 400	0 to 750	

NOTE: For TC inputs, the minimum span is 300 °C or 600 °F, which makes it possible to increase the sensitivity of the control parameters.

Current Transformer Input for OUT 1 Heater Breakdown Detection (Optional)

This feature allows measurement of the load current by means of a current transformer and signals an alarm condition when the current is below the pre-programmed threshold value.

Input Range: 50 mAac.

Scaling: Configurable from 10, 25, 50, and 100 Amps (with a 1 Amp step).

Display Resolution:

- For full scale up to 9.9 Amps: 0.1 Amp.
- For full scale from 10 Amps to 100 Amps: 1 Amp.

Active Period:

- For relay output: NO or NC configurable.
- For SSR output: logic level 1 or 0 configurable.

Minimum On time to perform the measurement: 50 ms.

Outputs

Main Output (Heating):

Relay or SSR (jumper selectable)

- Relay SPDT, contact rating 3 Amps @ 250 Vac on resistive load.
- Logic output for SSR, 700 Ω maximum load, short circuit protected.

Logic Level 1:

14 Vdc ±20% @ 20 mA

24 Vdc ±20% @ 1 mA

Logic Level 0:

Less than 0.5 Vdc

Output 2 (Cooling or Alarm 1):

NO or NC operation (jumper selectable)

Relay or SSR (jumper selectable)

- Relay SPST, contact rating 2 Amp @ 250 Vac on resistive load.

- Logic output for SSR, 700Ω maximum load, short circuit protected.

Logic Level 1:

14 Vdc ±20% @ 20 mA

24 Vdc ±20% @ 1mA

Logic Level 0:

Less than 0.5 Vdc

Output 3 (Alarm 2 or Heater breakdown)

- Relay SPST, contact rating 2 Amp @ 250 Vac on resistive load. (NO contact only)

Alarm Functions:

Process Alarm

Deviation Alarm

Band Alarm

Type of Alarm:

- High/Low (Outside/Inside for band alarm)
- Direct/Reverse
- Standby Sequence/No Standby Sequence

Alarm Hysteresis: 0.1 to 10.0% of input span or 1 least significant digit.

Alarm Output: Relay SPST 2 Amp @ 250 Vac resistive load.

Display characteristics

Upper Display: 3 digit 7 segment green LED display; 10 mm high.

Lower Display: 3 digit 7 segment orange LED display; 7.5 mm high.

Indicators:

- 1 red LED when main (heating) output is ON.
- 1 red LED when cooling (or alarm 1) output is ON.
- 1 red LED when alarm 2 (or hbd alarm) output is ON.
- 1 red LED when autotuning (Smart AT) is enabled.

CALIBRATION PROCEDURE

Calibration parameters are logically divided into groups of two parameters each - minimum range value and maximum range value. A calibration check is provided after entering the values of each group. A calibration check can be initiated without making an entry: press the FUNC key to advance to the desired calibration check (t. - rj. - P. - A.).

Before beginning calibration, open internal switch V2 (see configuration procedure Figure 2).

General Guidelines

- The instrument should be mounted in its case in order to keep the internal temperature constant.
- Ambient temperature should be stable. Avoid drift due to air conditioning or other mechanical devices.
- Relative humidity should not exceed 70%.
- Minimum warm up time should be at least 20 minutes.
- Operate as much as possible in a noise free environment.
- During calibration, connect one input at a time to the rear terminal block.
- Use calibrators with the following:

Accuracy	
TC Input	±0.005% output ±0.001% range ±5 microvolt
RTD Input:	±0.02% ±0.0025 Ω/decade
CJ Compensation:	Better than 0.1 °C

Resolution

TC Input:	±1 microvolt
RTD Input:	10 milliohm
CJ Compensation:	Better than 0.1 °C
Current transformer input	0.1 mA AC r.m.s.

Calibration Parameters

Following is a complete list of calibration symbols:

<u>Code</u>	<u>Parameter</u>
tL	TC Input Minimum Range Value
tH	TC Input Maximum Range Value
t.	TC Input Check
rJ	Cold Junction Compensation
r.J.	Cold Junction Compensation Check
PL	RTD Input Minimum Range Value
PH	RTD Input Maximum Range Value
P.	RTD Input Check
AL	Current Transformer Input Minimum Range Value
AH	Current Transformer Input Maximum Range Value
A.	Current Transformer Input Check

Procedure

Switch on the instrument; the display will show "CnF". Press the ▲ key and the display will show "CAL". Press the "FUNC" key to start the calibration process. Repeatedly press the FUNC key until the desired calibration (parameter) code appears.

The lower display will show the parameter code while the upper display shows "ON" or "OFF".

Use the ▲ key to select between ON and OFF. To go to the next parameter without modifying the calibration, press the FUNC key when the display shows "OFF".

To start parameter calibration, press the FUNC key when the display shows "ON".

NOTE: Press the MAN key to display the previous parameter without storing the new calibration.

Entering Calibration Values

tL TC input minimum range value

a) Connect calibrator and instrument as shown below.

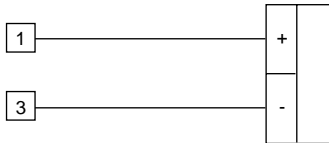

b) The upper display shows "OFF", the lower display shows "tL".

c) Set the calibrator to 0.000 mV.

d) Press the ▲ key; the display changes to "ON".

e) After a few seconds, start calibration by pressing the FUNC key. The decimal point of the least significant digit will light to indicate the instrument is performing the calibration. When calibration is complete, the instrument will proceed to the next parameter.

tH TC input maximum range value

a) The upper display shows "OFF", the lower display shows "tH".

b) Set the calibrator to 50.000 mV.

c) Press the ▲ key; the display changes to "ON".

d) After a few seconds, start calibration by pressing the FUNC key. The decimal point of the least significant digit will light to indicate the instrument is performing the calibration. When calibration is complete, the instrument will proceed to the TC input check.

t. TC input check

The display will show "t." followed by a number showing the measured value in counts. The calibration for "tH" is correct if the indication is "t.30 000" ± 10 counts.



a) Check the "Minimum Range" calibration (see parameter tL) by setting the calibrator to 0.000 mV - the readout must be equal to "t.00 000" ± 10 counts

b) Check linearity at half scale by setting 25.000 mV on the calibrator. The readout must be "t.15 000" ± 10 counts.

c) Check the "Maximum Range" calibration by setting the calibrator to 50.000 mV - the readout must be equal to "t.30 000" ± 10 counts

d) Press the FUNC key and the instrument will proceed to cold junction compensation.

rJ Cold junction compensation

NOTE: Make sure "tL" and "tH" are correctly calibrated before attempting "rJ" calibration.

a) Measure the temperature close to terminals 1 and 3 using an appropriate instrument, as shown below.

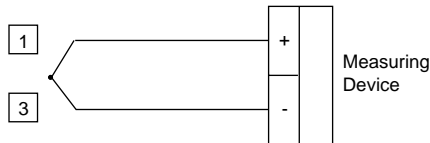

b) Wait a few minutes to allow temperature stabilization of the entire system (compensation cable, sensor, calibrator and instrument).

c) Using the ▲ and ▼ keys, make the readout value equal to the temperature measured by the measuring device in tenths of a °C.

d) After a few seconds, start calibration by pressing the FUNC key. The decimal point of the least significant digit will light to indicate the instrument is performing the calibration. When calibration is complete, the instrument will proceed to the cold junction compensation check.

rJ. Cold junction compensation check

The display will show "rJ." and the temperature in tenths of a degree, measured by the CJ compensator. Check that the display readout is equal to the value read by the measuring device.

Press the FUNC key, the instrument will proceed to RTD input minimum range value.

PL RTD input minimum range value

a) Connect a resistor box and the instrument as shown below.

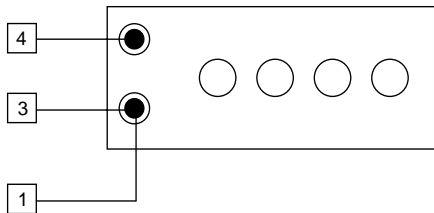

- b) The upper display shows "OFF", the lower display shows "PL".
- c) Set $0.000\ \Omega$ on the resistor box.
- d) Press the \blacktriangle key; the display changes to "ON".
- e) After a few seconds, start calibration by pressing the FUNC key. The decimal point of the least significant digit will light to indicate the instrument is performing the calibration. When calibration is complete, the instrument will proceed to the next parameter.

PH RTD input maximum range value

- a) The upper display shows "OFF", the lower display shows "PH".
- b) Set the resistor box to $300.000\ \Omega$.
- c) Press the \blacktriangle key; the display changes to "ON".
- d) After a few seconds, start calibration by pressing the FUNC key. The decimal point of the least significant digit will light to indicate the instrument is performing the calibration. When calibration is complete, the instrument will proceed to the RTD input check.

P. RTD input check

The display shows "P." followed by a number showing the measured value in counts. The calibration for "PH" is correct if the indication is "P:30 000" ± 10 counts.

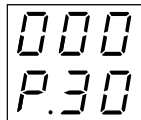

- a) Check the "Minimum Range" calibration by setting $0.000\ \Omega$ (see parameter PL) on the resistance box; the readout should be "P00 000" ± 10 counts.
- b) Check the "Maximum Range" calibration by setting $375.000\ \Omega$ on the resistance box; the readout should be "P. 3 0000" ± 10 counts.

c) Check linearity.

NOTE: The relation between the input signal and counts for RTD input is not linear. The correct relation is shown in the following table:

Resistor Box	Display Counts
0	0 ± 10 counts
100	1 0153 ± 10 counts
200	2 0151 ± 10 counts
300	3 0000 ± 10 counts

d) Press the FUNC key, the instrument will proceed to the current transformer minimum range calibration.

AL Current transformer minimum range value

a) Connect the calibrator and instrument as shown below.

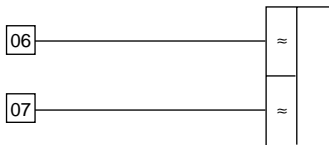

b) The upper display shows "OFF", the lower display shows "AL".

c) Set calibrator to 0.000 mA.

d) Press the \blacktriangle key; the display changes to "ON".

e) After a few seconds, start calibration by pressing the FUNC key. The decimal point of the least significant digit will light to indicate the instrument is performing the calibration. When calibration is complete, the instrument will proceed to the next parameter.

AH Current transformer maximum range value

a) The upper display shows "OFF", the lower display shows "AH".

b) Set calibrator to 50.000 mA r.m.s.

c) Press the \blacktriangle key; the display changes to "ON".

d) After a few seconds, start calibration by pressing the FUNC key. The decimal point of the least significant digit will light to indicate the instrument is performing the calibration. When calibration is complete, the instrument will proceed to the current transformer input check.

A. Current transformer input check

The display shows "A." followed by a number showing the measured value in counts. The calibration for "AH" is correct if the indication is "A.01 000" ± 10 counts.

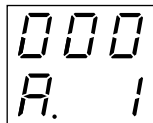

a) Check the "Minimum Range" calibration by setting 0.000 mA (see parameter nAL) on the calibrator; the readout should be "A.00 000" ± 10 counts.

b) Check the linearity at half scale by setting 25.000 mA r.m.s. on the calibrator; the readout should be "A.00 500" ± 10 counts.

c) Check the "Maximum Range" calibration by setting 50.000 mA r.m.s. on the calibrator; the readout should be "A.01 000" ± 10 counts.

This completes the calibration procedure. To enter the configuration procedure press the \blacktriangle key, the display will show "CrF". If configuration and calibration are complete, switch the instrument off and close the switch V2 (see configuration procedure Figure 2).

MAINTENANCE

1. Disconnect the power from the power supply terminals and relay output terminals.
2. Remove the instrument from its case.
3. Using a vacuum cleaner or a compressed air jet (max. 3 kg/cm^2) remove dust and dirt which may be present on the louvers and on the internal circuits, being careful to not damage the electronic components.
4. Clean external plastic or rubber parts with a cloth moistened with ethyl alcohol (pure or denatured) [$\text{C}_2\text{H}_5\text{OH}$]; or isopropyl alcohol (pure or denatured) [$(\text{CH}_3)_2\text{CHOH}$]; or water [H_2O].
5. Verify that there are no loose terminals.
6. Before re-inserting the instrument in its case, be sure it is dry.
7. Re-insert the instrument and turn it on.

Notes...



Barber-Colman Company
Industrial Instruments Division
1354 Clifford Avenue
P.O. Box 2940
Loves Park, IL U.S.A. 61132-2940

Telephone +1 800 232 4343
Facsimile +1 815 637 5341
<http://www.barber-colman.com>

A Siebe Group Company

Copyright © 1998 Barber-Colman Company.