

# KIT33901EFEVB Evaluation Board

Featuring the MC33901 High Speed CAN Transceiver



Figure 1. KIT33901EFEVB Evaluation Board

## Contents

1 Kit Contents/Packing List	2
2 Jump Start	2
3 Important Notice	3
4 Introduction	4
5 Evaluation Board Features	4
6 MC33901 Device Features	4
7 Required Equipment	4
8 Evaluation Board Configuration with Single Power Supply	5
9 Evaluation Board Configuration with Dual Power Supply	6
10 Using the EVB	7
11 Evaluation Board Hardware Configuration	8
12 Schematic	10
13 Board Layout	11
14 Bill of Material	12
15 References	14
16 Revision History	15

## 1 Kit Contents/Packing List

- Assembled and tested evaluation board/module in anti-static bag
- Warranty card

## 2 Jump Start

- Go to [www.freescale.com/analogtools](http://www.freescale.com/analogtools)
- Locate your kit
- Review your Tool Summary Page
- Look for



### **Jump Start Your Design**

- Download documents, software, and other information

### 3 Important Notice

Freescale provides the enclosed product(s) under the following conditions:

This evaluation kit is intended for use of ENGINEERING DEVELOPMENT OR EVALUATION PURPOSES ONLY. It is provided as a sample IC pre-soldered to a printed circuit board to make it easier to access inputs, outputs, and supply terminals. This evaluation board may be used with any development system or other source of I/O signals by simply connecting it to the host MCU or computer board via off-the-shelf cables. This evaluation board is not a Reference Design and is not intended to represent a final design recommendation for any particular application. Final device in an application will be heavily dependent on proper printed circuit board layout and heat sinking design as well as attention to supply filtering, transient suppression, and I/O signal quality.

The goods provided may not be complete in terms of required design, marketing, and or manufacturing related protective considerations, including product safety measures typically found in the end product incorporating the goods. Due to the open construction of the product, it is the user's responsibility to take any and all appropriate precautions with regard to electrostatic discharge. In order to minimize risks associated with the customers applications, adequate design and operating safeguards must be provided by the customer to minimize inherent or procedural hazards. For any safety concerns, contact Freescale sales and technical support services.

Should this evaluation kit not meet the specifications indicated in the kit, it may be returned within 30 days from the date of delivery and will be replaced by a new kit.

Freescale reserves the right to make changes without further notice to any products herein. Freescale makes no warranty, representation or guarantee regarding the suitability of its products for any particular purpose, nor does Freescale assume any liability arising out of the application or use of any product or circuit, and specifically disclaims any and all liability, including without limitation consequential or incidental damages. "Typical" parameters can and do vary in different applications and actual performance may vary over time. All operating parameters, including "Typical", must be validated for each customer application by customer's technical experts.

Freescale does not convey any license under its patent rights nor the rights of others. Freescale products are not designed, intended, or authorized for use as components in systems intended for surgical implant into the body, or other applications intended to support or sustain life, or for any other application in which the failure of the Freescale product could create a situation where personal injury or death may occur.

Should the Buyer purchase or use Freescale products for any such unintended or unauthorized application, the Buyer shall indemnify and hold Freescale and its officers, employees, subsidiaries, affiliates, and distributors harmless against all claims, costs, damages, and expenses, and reasonable attorney fees arising out of, directly or indirectly, any claim of personal injury or death associated with such unintended or unauthorized use, even if such claim alleges that Freescale was negligent regarding the design or manufacture of the part. Freescale™ and the Freescale logo are trademarks of Freescale Semiconductor, Inc. All other product or service names are the property of their respective owners.

© Freescale Semiconductor, Inc. 2014

## 4 Introduction

This evaluation board allows the user to implement and test the functionalities of the MC33901, High Speed CAN transceiver.

## 5 Evaluation Board Features

The KIT33901EFEVB Evaluation Board is an easy-to-use circuit board that allows the user to exercise the function of the MC33901, High Speed CAN transceiver.

- Supply from a single 5.0 V, or dual 5.0 V and 3.3 V supplies
- Local switches for single or dual supply selection
- Switches for device operating mode selection
- Footprint for optional CAN bus filter and protection component
- 8-pin Single In Line connector to access MC33901 device pins
- Two LEDs to display board and MC33901 state

## 6 MC33901 Device Features

The MC33901 provides the physical interface between the CAN protocol controller of an MCU and the physical dual wire CAN bus. They are packaged in an 8-pin SOIC with market standard pin out, and offer excellent EMC and ESD performance without the need for external filter components.

- MC33901 is a standalone High Speed CAN transceiver
- Available with several options and part numbers, for automotive and industrial applications
- Operates with 5.0 V and 3.3 V MCU using VIO input pin
- Normal and Low-power modes
- Device version with bus wake-up, which reports wake-up on the RXD pin
- Integrated TXD dominant protection (MC33901 version)

Freescale analog ICs are manufactured using the SMARTMOS process, a combinational BiCMOS manufacturing flow which integrates precision analog, power functions, and dense CMOS logic on a single cost-effective die.

## 7 Required Equipment

To use this kit you will need:

- 5.0 V power supply, 150 mA capability
- 3.3 V power supply, 50 mA capability. Usage of this second supply depends on the user requirement.
- Signal generator, output frequency up to 1.0 MHz and output voltage at least 5.0 V
- An optional oscilloscope to monitor the CAN signals
- Cables with 2.0 mm banana plugs

# 8 Evaluation Board Configuration with Single Power Supply

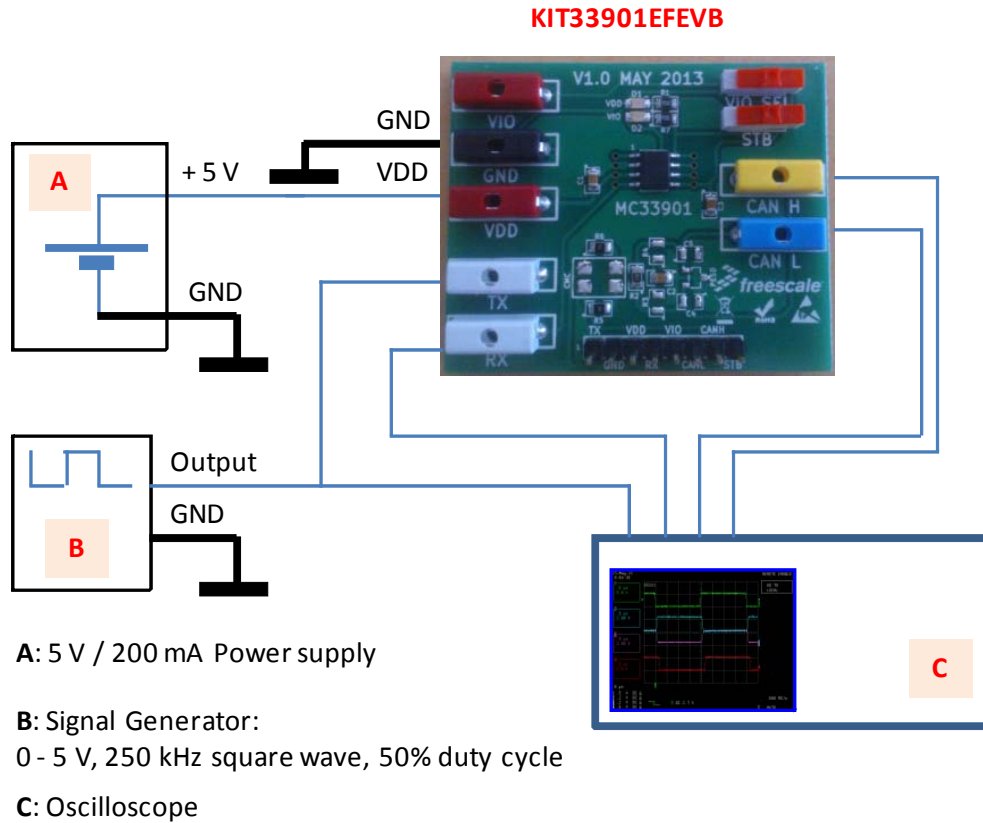

Figure 2. KIT33901EFEVB Board Setup with Single Power Supply

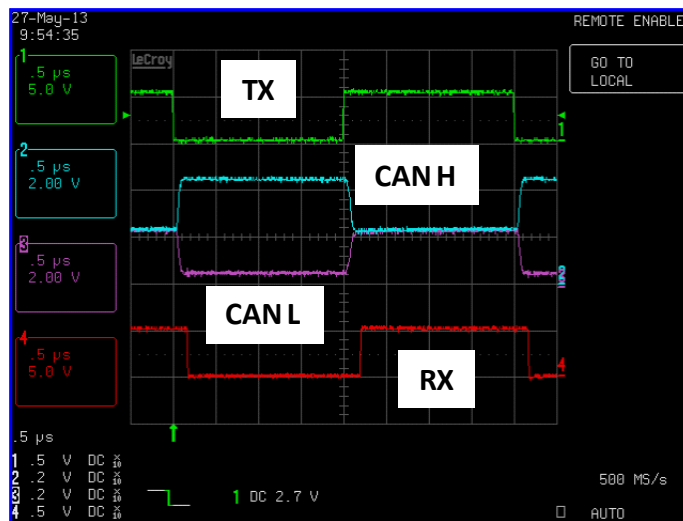

Figure 3. Output Signals

## 9 Evaluation Board Configuration with Dual Power Supply

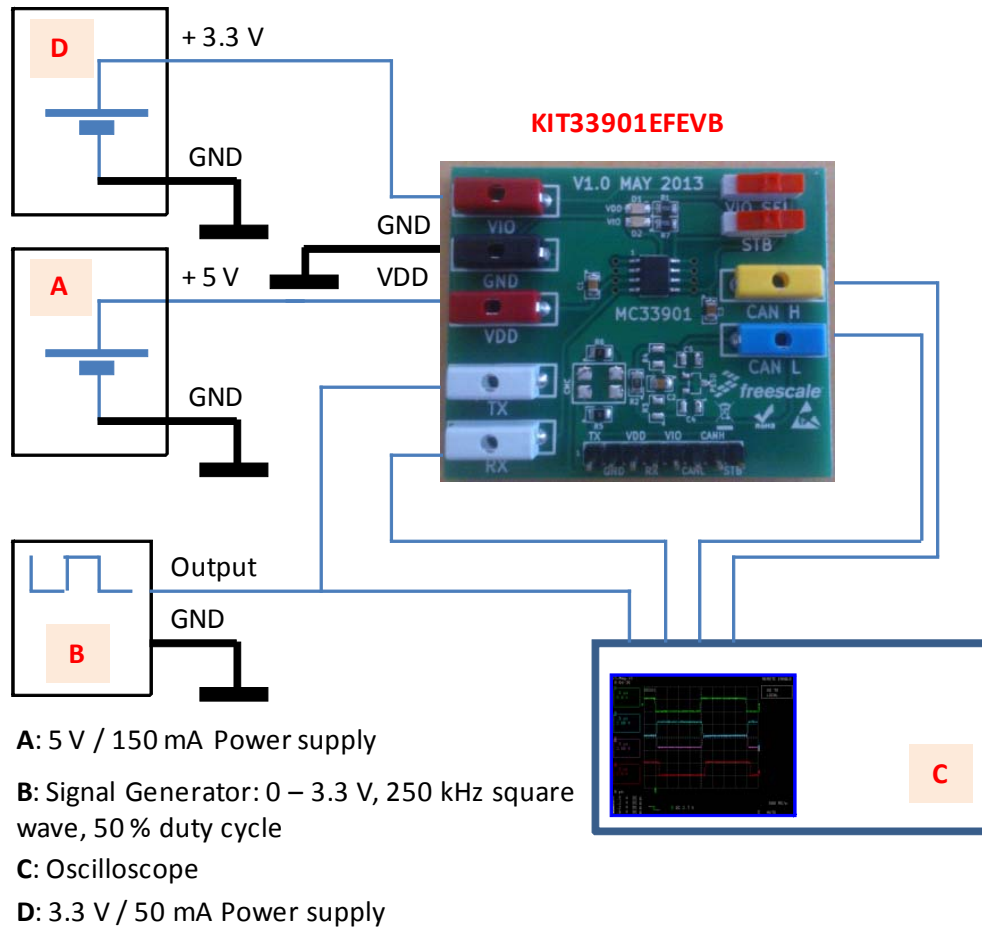

Figure 4. KIT33901EFEVB Board Setup with Dual Power Supply

## 10 Using the EVB

The KIT33901EFEVB and the MC33901 device can be used with a single 5.0 V supply, or with dual supplies 5.0 V and 3.3 V.

### 10.1 Single Supply

1. To use the board and device with a single supply, set the **VIO SEL** switch to left.
2. Set the power supply to 5.0 V.
3. To use the device in Normal mode, set the **STB** switch to right.
  - Connect a 0 - 5.0 V square signal to **TX**, frequency 250 kHz and duty cycle 50%.
  - Connect an oscilloscope to **CANH**, **CANL**, and **RX** terminals.
  - Observe CANH, CANL, and RX signals on the oscilloscope.
4. To use the device in Standby mode, set the **STB** switch to left.
  - Observe TX signal on the oscilloscope. In Standby mode, TX signal is high.
  - Apply CAN signal on **CANH** and **CANL**.
  - **RX** reports bus state (dominant or recessive), once the wake-up filter criteria is met.

### 10.2 Dual Supply

1. To use the board and device with dual supply, set the **VIO SEL** switch to right.
2. Set the VDD power supply to 5.0 V, and the VIO power supply to 3.3 V.
3. To use the device in Normal mode, set the **STB** switch to right.
  - Connect a 0 - 3.3 V square signal to **TX**, frequency 250 kHz and duty cycle 50%.
  - Connect an oscilloscope to **CANH**, **CANL**, and **RX** terminals.
  - Observe CANH, CANL, and RX signals on the oscilloscope.
4. To use the device in Standby mode, set the **STB** switch to left.
  - Observe TX signal on the oscilloscope. In Standby mode, TX signal is high.
  - Apply CAN signal on **CANH** and **CANL**.
  - **RX** reports bus state (dominant or recessive), once the wake-up filter criteria is met.

# 11 Evaluation Board Hardware Configuration

- The board is supplied from a unique 5.0 V supply, connected to the GND and VDD plugs. In this case, the VIO\_SEL switch is positioned left.
- An additional 3.3 V supply is connected to the GND and VIO plugs. In this case, the VIO\_SEL jumper switch is positioned right.
- A signal generator is connected to the GND and TX plugs.
- An oscilloscope is connected to the CANH and CANL plugs, and optionally to RX and TX.

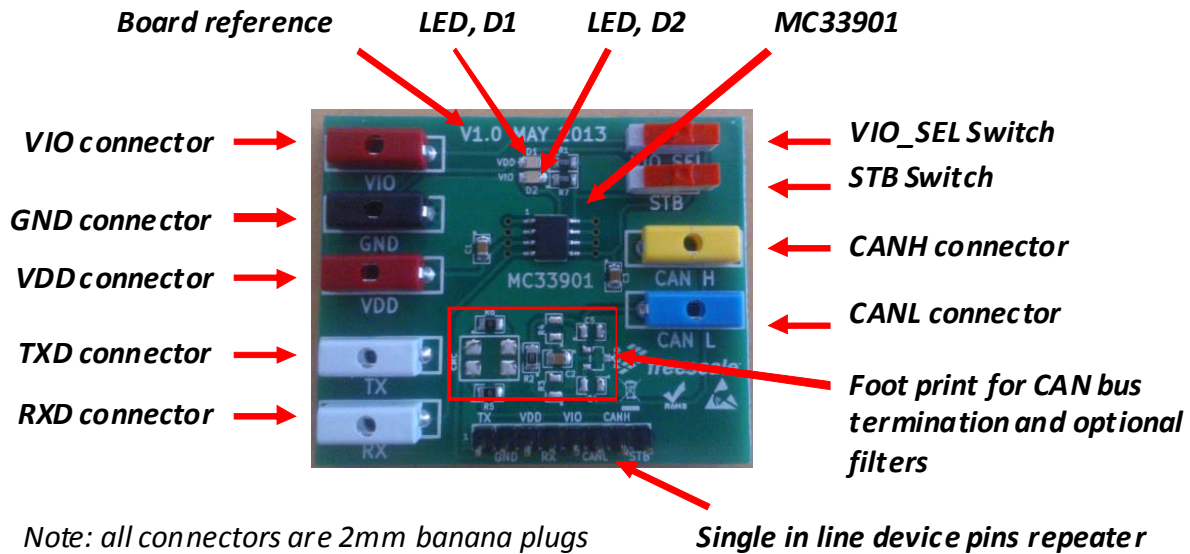

Figure 5. Jumper, Resistor, and Switch Settings

Table 1. Jumper and Switch Settings

Device Mode	Board Supply	STB Switch	VIO_SEL Switch	D1 LED	D2 LED	Comment
Standby	Single	Left	Left	ON	OFF	Device in Standby mode. Single 5.0 V supply for VDD and VIO. No CAN path from TX to bus. Bus wake-up reported on RX.
Normal	Single	Right	Left	ON	ON	Device in Normal mode. Single 5.0 V supply for VDD and VIO. CAN path from TX to bus and from bus to RX.
Standby	Dual	Left	Right	ON	OFF	Device in Standby mode. 5.0 V supply for VDD and 3.3 V for VIO. No CAN path from TX to bus. Bus wake-up reported on RX.
Normal	Dual	Right	Right	ON	ON	Device in Normal mode. 5.0 V supply for VDD and 3.3 V for VIO. CAN path from TX to bus and from bus to RX.



## 11.1 CAN Bus Termination Configuration

The board allows multiple variations for the mounting and usage of the external components. [Figure 6](#) shows multiple options.

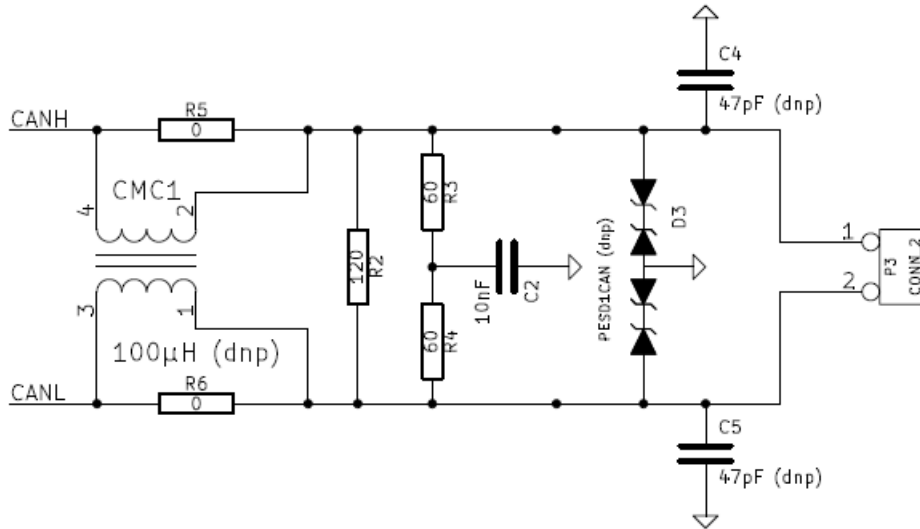

Figure 6. CAN Bus Termination

## 11.2 External Component Definition

This section defines the purpose and usage of the CAN bus termination components:

- R2, R3, R4, and C2: bus termination option (no termination, 60 Ohm, 120 Ohm, or split termination)
- R5, R6, and CMC1: common mode choke utilization
- C4, C5, and D3: extra bus filter and ESD protection

Table 2. External Component Definition

Use Case	R2	R3, R4, C2	R5, R6, CMC	C4, C5	D3
No termination	DNP	DNP	-	-	-
60 or 120 Ohm termination	Populate with R2 = 120 or R2 = 60 Ohm	DNP	-	-	-
Split termination (R3, R4, C2)	DNP	Populate with R3 = R4= 60 Ohm, C2 = 4.7 nF (example only)	-	-	-
No common mode choke	-	-	Populate R5 & R6 with zero Ohm	-	-
With common mode choke	-	-	R5 and R6 DNP. Populate CMC (ex 51uH)	-	-
Extra bus filter	-	-	-	Populate with 100pF (example)	-
Extra ESD protection	-	-	-	-	Populate with NUP2105 (example)

Notes

1. **DNP:** Do not Populate

# 12 Schematic

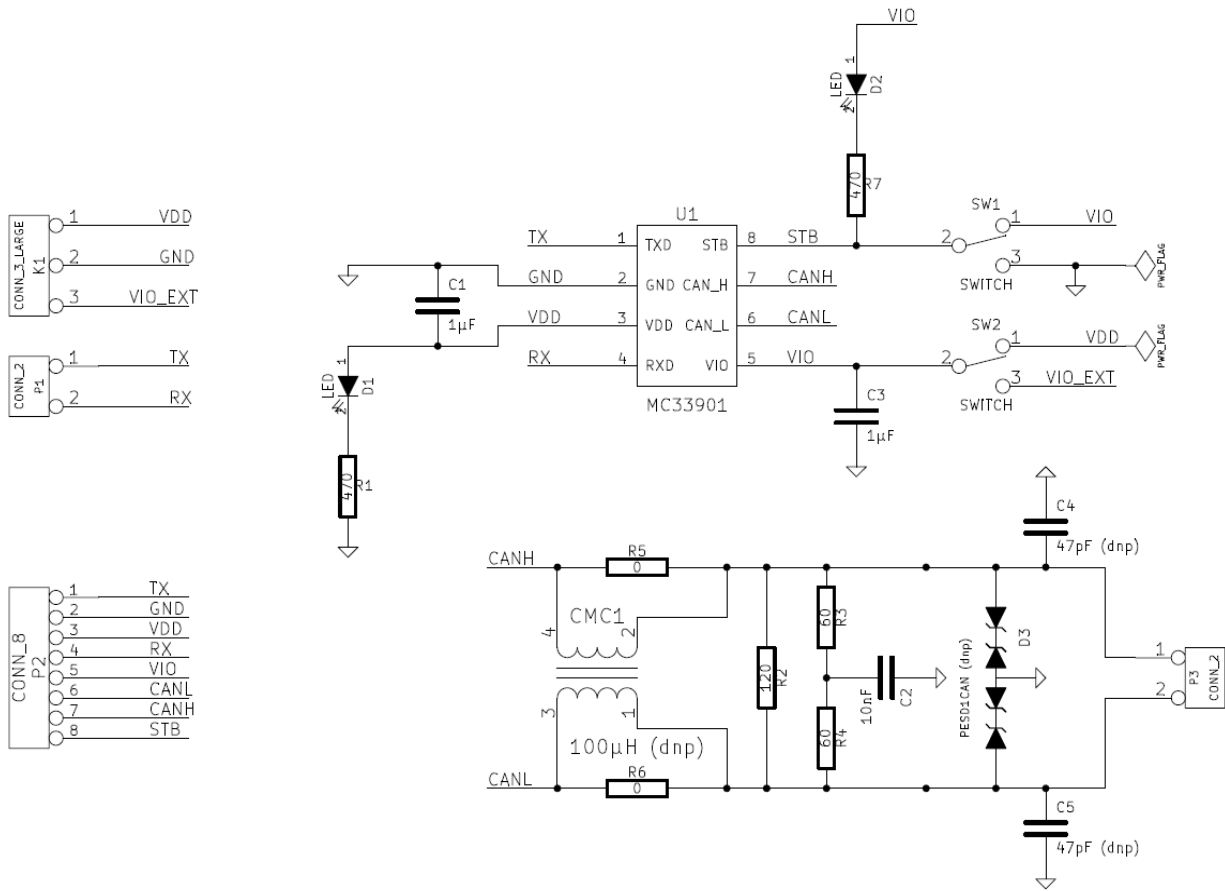

Figure 7. Evaluation Board Schematic

## 13 Board Layout

### 13.1 Top Layer Routing

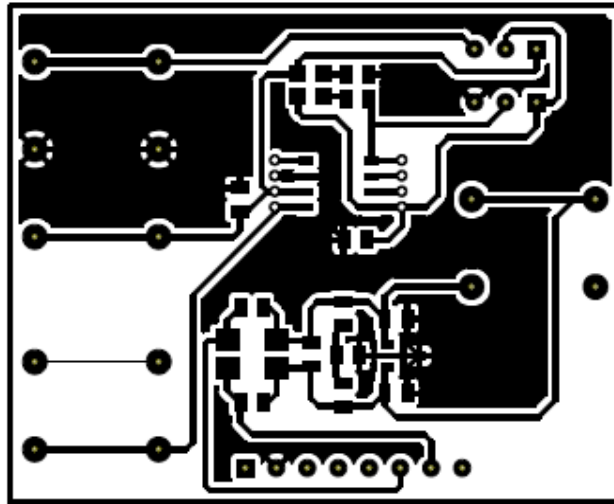

Figure 8. Top Layer Routing

### 13.2 Bottom Layer Routing

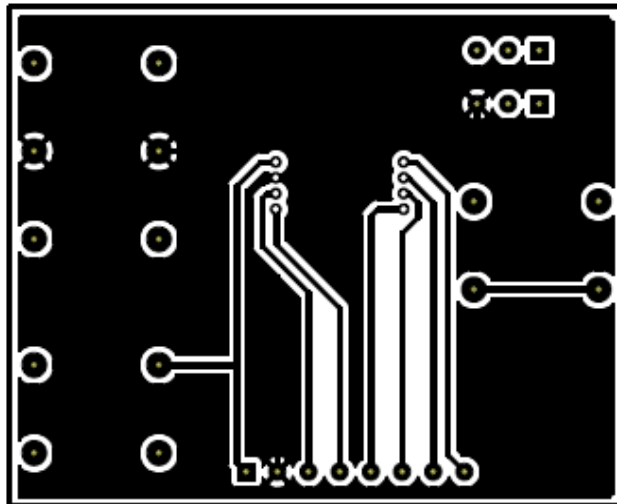

Figure 9. Bottom Layer Routing

# 14 Bill of Material

Qty	Schematic Label	Value	Description	Package	Populate
<b>Freescale Component</b>					
1	U1	-	MC33901	SOIC8	Yes
<b>Diodes</b>					
1	D1	LED0805	LED	0805	Yes
1	D2	LED0805	LED	0805	Yes
1	PESD1CAN1	PESD1CAN1	Zener	-	DNP
<b>Capacitors</b>					
1	C1	1 $\mu$ F	Capacitor	0805	Yes
1	C2	10nF	Capacitor	0805	Yes
1	C3	1 $\mu$ F	Capacitor	0805	Yes
1	C4	47pF	Capacitor	0805	DNP
1	C5	47pF	Capacitor	0805	DNP
<b>Resistors</b>					
1	R1	470 ohm	Resistor	0805	Yes
1	R2	120 ohm	Resistor	0805	Yes
1	R3	60 ohm	Resistor	0805	DNP
1	R4	60 ohm	Resistor	0805	DNP
1	R5	0	Resistor	0805	Yes
1	R6	0	Resistor	0805	Yes
1	R7	470 ohm	Resistor	0805	Yes

Qty	Schematic Label	Value	Description	Package	Populate
<b>Switches, Connectors, Jumpers and Test Points</b>					
1	RX	2mm banana plug	Connector	-	Yes
1	CAN_H1	2mm banana plug	Connector	-	Yes
1	CAN_L1	2mm banana plug	Connector	-	Yes
1	CMC1	B82789_100μH	Inductor	-	DNP
1	CONN1	Connector 8-pin	Connector Single In Line	-	Yes
1	GND1	2mm banana plug	Connector	-	Yes
1	SW1	Switch 2 positions	Connector	-	Yes
1	SW2	Switch 2 positions	Connector	-	Yes
1	TX	2mm banana plug	Connector	-	Yes
1	VDD1	2mm banana plug	Connector	-	Yes
1	VIO	2mm banana plug	Connector	-	Yes

## Notes

2. Freescale does not assume liability, endorse, or warrant components from external manufacturers that are referenced in circuit drawings or tables. While Freescale offers component recommendations in this configuration, it is the customer's responsibility to validate their application.
3. **DNP:** Do not Populate

## 15 References

Following are URLs where you can obtain information on related Freescale products and application solutions:

Freescale.com Support Pages	URL
MC33901 Data Sheet	<a href="http://www.freescale.com/files/analog/doc/data_sheet/MC33901.pdf">http://www.freescale.com/files/analog/doc/data_sheet/MC33901.pdf</a>
MC33901 Product Summary Page	<a href="http://www.freescale.com/webapp/sps/site/prod_summary.jsp?code=MC33901">http://www.freescale.com/webapp/sps/site/prod_summary.jsp?code=MC33901</a>
AN2409 Application Note	<a href="http://www.freescale.com/files/analog/doc/app_note/AN2409.pdf">http://www.freescale.com/files/analog/doc/app_note/AN2409.pdf</a>
Analog Home Page	<a href="http://www.freescale.com/analog">http://www.freescale.com/analog</a>
Automotive Home Page	<a href="http://www.freescale.com/automotive">http://www.freescale.com/automotive</a>

### 15.1 Support

Visit [www.freescale.com/support](http://www.freescale.com/support) for a list of phone numbers within your region.

### 15.2 Warranty

Visit [www.freescale.com/warranty](http://www.freescale.com/warranty) for a list of phone numbers within your region.

## 16 Revision History

Revision	Date	Description of Changes
1.0	2/2014	• Initial Release



**How to Reach Us:**

**Home Page:**  
[freescale.com](http://freescale.com)

**Web Support:**  
[freescale.com/support](http://freescale.com/support)

Information in this document is provided solely to enable system and software implementers to use Freescale products. There are no express or implied copyright licenses granted hereunder to design or fabricate any integrated circuits based on the information in this document.

Freescale reserves the right to make changes without further notice to any products herein. Freescale makes no warranty, representation, or guarantee regarding the suitability of its products for any particular purpose, nor does Freescale assume any liability arising out of the application or use of any product or circuit, and specifically disclaims any and all liability, including without limitation consequential or incidental damages. "Typical" parameters that may be provided in Freescale data sheets and/or specifications can and do vary in different applications, and actual performance may vary over time. All operating parameters, including "typicals," must be validated for each customer application by customer's technical experts. Freescale does not convey any license under its patent rights nor the rights of others. Freescale sells products pursuant to standard terms and conditions of sale, which can be found at the following address: [freescale.com/SalesTermsandConditions](http://freescale.com/SalesTermsandConditions).

Freescale and the Freescale logo are trademarks of Freescale Semiconductor, Inc., Reg. U.S. Pat. & Tm.Off. SMARTMOS is a trademark of Freescale Semiconductor, Inc. All other product or service names are the property of their respective owners.

© 2014 Freescale Semiconductor, Inc.

Document Number: KT33901UG  
Rev. 1.0  
2/2014

