

CONTACTS	DIMENSIONS	
	A	B
2	5.08	2.54
3	7.62	5.08
4	10.16	7.62
5	12.70	10.16
6	15.24	12.70

SPECIFICATIONS 规格

CURRENT RATING 电流额定值: 3 Amp
 INSULATION RESISTANCE 绝缘电阻值: 1000 MΩ min.
 DIELECTRIC WITHSTANDING 耐电压: 500V AC/minute
 CONTACT RESISTANCE 接触电阻值: 20 mΩ MAX.
 OPERATING TEMPERATURE 工作温度: -40°C TO +105°C
 CONTACT MATERIAL 端子物料: PHOSPHOR BRONZE
 PLATING 电镀: CONTACT AREA 接触面积: 50μ" - 100μ" NICKEL UNDERPLATE, FOR PLATING
 SEE ORDERING GRID.
 INSULATOR MATERIAL 绝缘体物料: POLYESTER 聚酯, LCP 30% GLASS FILLED, NATURAL, UL94V-0
 SOLDERING PROCESS 可焊性:
 IR REFLOW 回流焊: 260°C FOR 10 SEC.
 MANUAL SOLDER 人工焊接: 350°C FOR 3-5 SEC

MATES WITH 配套之公头:
 BG301 - SELECT 4.00mm PIN LENGTH 选择 4.00mm 引脚长度, BG303, BG304 & BG305

NOTES 备注:
 STANDARD BLACK VERSION OF BG306 IS BG125
 BG306 的标准黑色塑胶版本为料号为 BG125

Ordering Grid

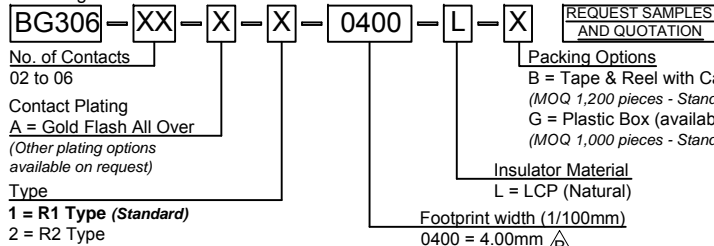

Packing Options

B = Tape & Reel with Cap (available in 3, 4, 5 & 6 contacts)
 (MOQ 1,200 pieces - Standard R1 Footprint)
 G = Plastic Box (available in 2 contacts)
 (MOQ 1,000 pieces - Standard R1 Footprint)

By	ASE	AJO	AJO
DETAIL	DRAWING RELEASE	SELECTABLE WIDTH REMOVED	PACKING DRAWING ADDED
REV DATE	A 18/04/12	B 16/07/12	C 18/06/13



Tolerances (Except as noted)	Part Number:-	Date:-
Dimensions in mm	BG306	18 APR 12
X.X ± 0.30	Description:- 2.54mm PITCH PIN SOCKET, SINGLE ROW, VERTICAL, TOP ENTRY, SURFACE MOUNT, NATURAL LCP	THIS DRAWING IS CONFIDENTIAL AND MUST NOT BE COPIED OR DISCLOSED WITHOUT WRITTEN CONSENT
X.XX ± 0.20		
Third Angle Projection	Scale NTS	Revision C
	Material See Note	Drawn by ASE
	E & OE	Sheet No. 1/1



3 PIN - For packaging information, please contact GCT

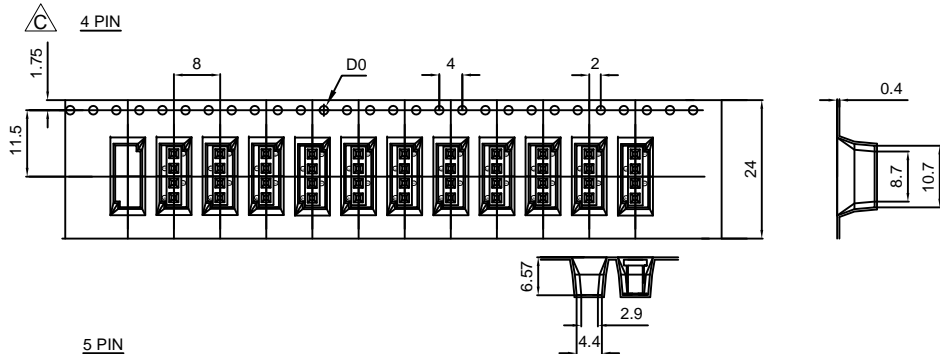

5 PIN

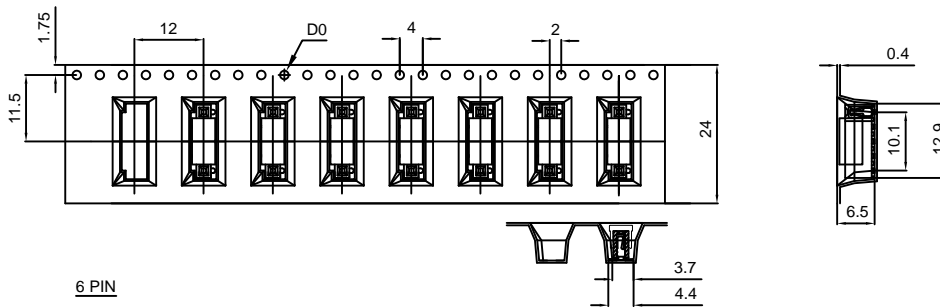

6 PIN

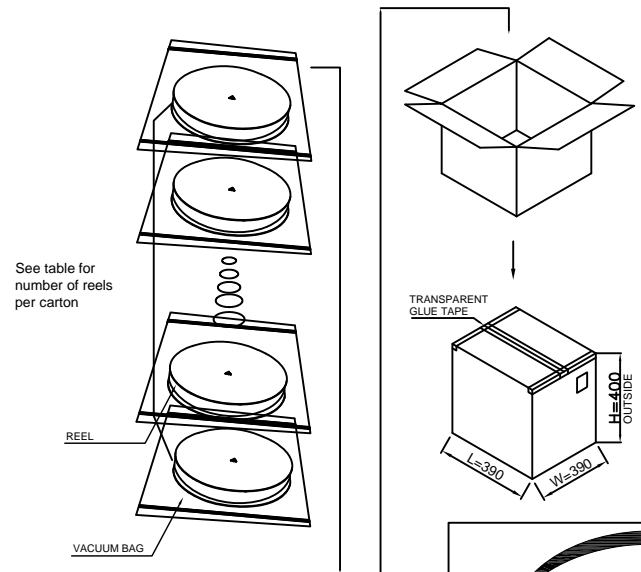
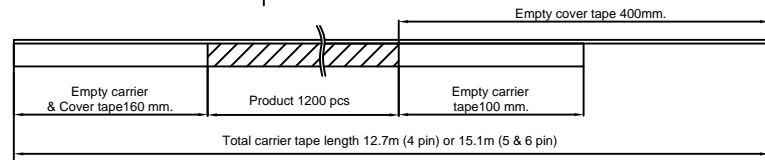
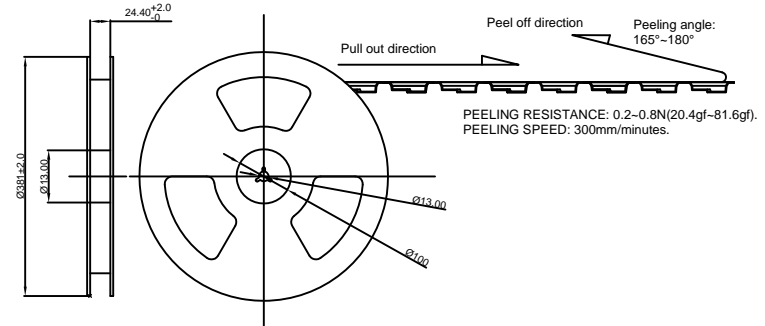
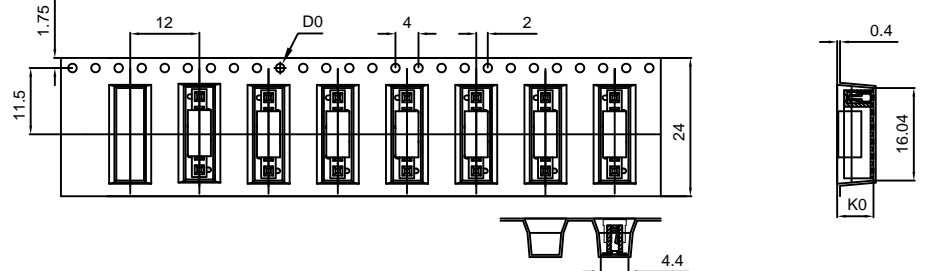

PINS	UNITS/REEL	REELS PER CARTON	CARTON	TOTAL CARRIER TAPE LENGTH
4	1200 PCS	8	9,600	12.7 m
5	1200 PCS	8	9,600	15.1 m
6	1200 PCS	8	9,600	15.1 m

By	ASE	AJO	AJO
DETAIL	DRAWING RELEASE	SELECTABLE WIDTH REMOVED	PACKING DRAWING ADDED
REV DATE	A 18/04/12	B 16/07/12	C 18/06/13



Tolerances (Except as noted)		Part Number:-	Date:-
Dimensions in mm		BG306	18 APR 12
X. ± 0.30	X. ° ± 4.0°	Description:- 2.54mm PITCH PIN SOCKET, SINGLE ROW, VERTICAL, TOP ENTRY, SURFACE MOUNT, NATURAL LCP	
X.X ± 0.20	X.X° ± 3.0°		
X.XX ± 0.30	X.XX° ± 2.0°		
X.XXX ± 0.20	X.XXX° ± 1.0°		
Third Angle Projection		THIS DRAWING IS CONFIDENTIAL AND MUST NOT BE COPIED OR DISCLOSED WITHOUT WRITTEN CONSENT	

White Lite
GCT
 www.gct.co

Scale NTS	Revision C	Material See Note	Drawn by ASE	Sheet No. 1/1
			E & OE	