

LED Super Bright SMD



Features:

- RGB LED lamp
- Low Profile Package
- All chips can be individually driven to provide required colours

OVS 33 Series

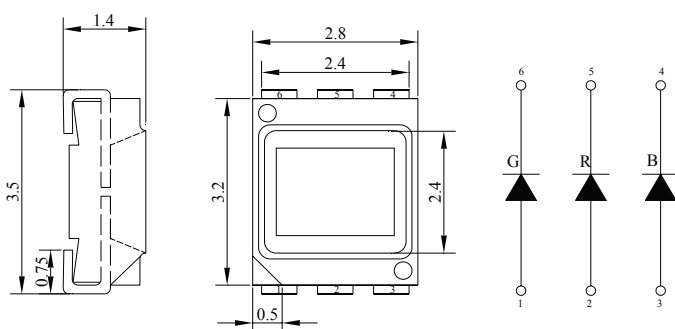

Dimensions: Millimetres

Maximum Ratings at Ta = 25°C

Reverse Voltage (<math><100\mu\text{A}</math>)	: 5V
D.C. Forward Current	: 30mA
Pulse Current (Pulse Width od 0.1ms, 1/10 Duty Cycle)	: 100mA
Operating Temperature Range	: -25°C to +85°C
Storage Temperature Range	: -40°C to +100°C
Soldering Temperature Reflow Soldering	: 260°C for 10 secs

Electrical & Optical Characteristics at Ta = 25°C

LED Chip			Lens Colour	Dominant Wavelength (nm) at 20mA	Luminous Intensity (mcd) at 20mA		Forward Voltage (V) at 20mA		Viewing Angle $2\theta^{1/2}$ (deg)
Material	Emitted Colour	Brightness			Min.	Typ.	Typ.	Max.	
InGaN / Sapphire	Blue	Mega	Water Clear	470	45	100	3.5	120	
InGaN / Sapphire	True Green			520	200	470	3.2		4.2
A1GalnP/Si	Red			625	244	450	2.1		2.6

www.element14.com
www.farnell.com
www.newark.com



LED Super Bright SMD



Radiation Diagram(s)

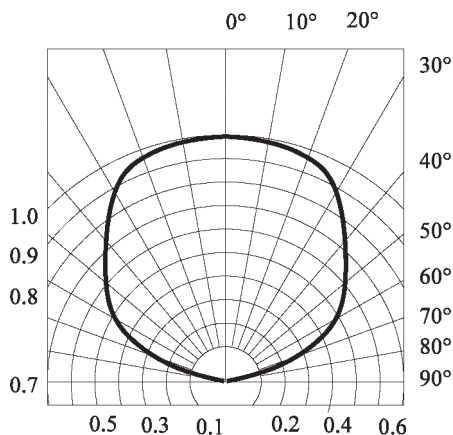

Storage

Recommended storage environment

Temperature : 5°C to 30°C (41°F to 86°F)

Humidity : 60% RH Max.

Use within 7 days after opening of sealed vapor/ESD barrier bags. If unused LEDs remain, they should be stored in moisture proof packages, such as sealed container with packages of moisture absorbent material (silica gel). It is also recommended to return the LEDs to the original moisture proof bag and to reseal the moisture proof bag again. Fold the opened bag firmly and keep in dry environment.

Soldering

Reflow Soldering			Hand Soldering	
	Lead Solder	Lead - Free Solder		
Pre-heat	120°C to 150°C	180°C to 200°C	Temperature	350°C Max.
Pre-heat time	120 sec. Max.	120 sec. Max.	Soldering time	3 sec. Max. (one time only)
Peak temperature	240°C Max.	260°C Max.		
Soldering time	10 sec. Max.	10 sec. Max.		
Condition	refer to Temperature - profile 1	refer to Temperature - profile 2		

*After reflow soldering rapid cooling should be avoided

[Temperature-profile (Surface of circuit board)]

Use the conditions shown to the under figure



LED Super Bright SMD



1 : Lead Solder

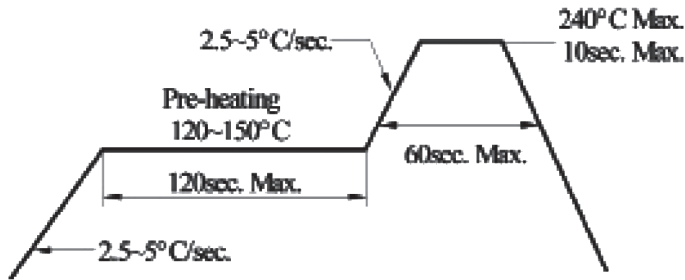

2 : Lead-free Solder

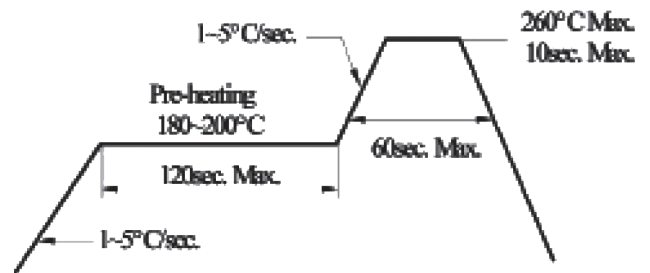

Dimensions: Millimetres

Recommended Soldering Pad Design

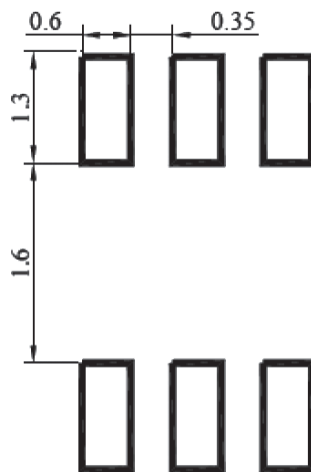

Part Number Table

Description	Part Number
LED 3.2mm × 2.8mm × 1.4mm SMD RGB	OVS-3309

Important Notice : This data sheet and its contents (the "Information") belong to the members of the Premier Farnell group of companies (the "Group") or are licensed to it. No licence is granted for the use of it other than for information purposes in connection with the products to which it relates. No licence of any intellectual property rights is granted. The Information is subject to change without notice and replaces all data sheets previously supplied. The Information supplied is believed to be accurate but the Group assumes no responsibility for its accuracy or completeness, any error in or omission from it or for any use made of it. Users of this data sheet should check for themselves the Information and the suitability of the products for their purpose and not make any assumptions based on information included or omitted. Liability for loss or damage resulting from any reliance on the Information or use of it (including liability resulting from negligence or where the Group was aware of the possibility of such loss or damage arising) is excluded. This will not operate to limit or restrict the Group's liability for death or personal injury resulting from its negligence. Multicomp is the registered trademark of the Group. © Premier Farnell plc 2014.

