

IEC Appliance Inlet C6, Screw-on Mounting, Front or Rear Side, Solder, PCB or Quick-connect Terminal



Description

- Panel Mount:
Screw-on mounting, Front Side
- 1 Function:
Appliance Inlet, Pin temperature 70 °C Protection class I
- Solder, Quick Connect or PCB Terminal

Approvals

- VDE Certificate Number: 40002273
- UL File Number: E96454
- CSA File Number: 27324

Characteristics

- Contact pins are turned from solid material

References

We recommend for new applications the type [0724](#)

Weblinks

[pdf-datasheet](#), [html-datasheet](#), [General Product Information](#), [Approvals](#), [CE declaration of conformity](#), [RoHS](#), [CHINA-RoHS](#), [REACH](#), [Mating Connectors](#), [e-Shop](#), [SCHURTER-Stock-Check](#), [Distributor-Stock-Check](#), [CAD-Drawings](#), [Accessories](#), [Detailed request for product](#)

Technical Data

Ratings IEC	2.5 A / 250 VAC; 50 Hz
Ratings UL/CSA	2.5 A / 250 VAC; 60 Hz
Dielectric Strength	> 4 kVAC between L-N > 2 kVAC between L/N-PE (1 min/50 Hz)
Allowable Operation Temp.	-25 °C to 70 °C
Degree of Protection	from front side IP 20 acc. to IEC 60529
Protection Class	Suitable for appliances with protection class I acc. to IEC 61140
Material: Housing	PA6, black, UL 94V-0

Appliance Inlet	C6 acc. to IEC 60320 UL 498, CSA C22.2 no. 42 (for cold conditions) pin-temperature 70 °C, 2.5 A, Protection Class I
-----------------	---

Dimensions

Solder or quick connect terminals

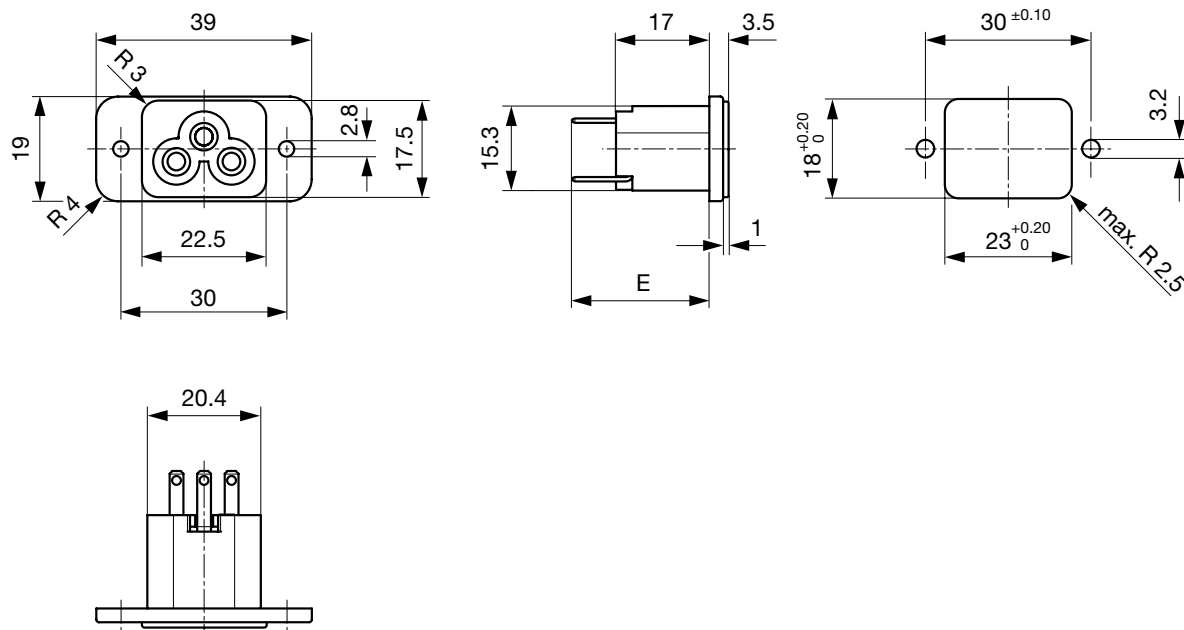

- E: Solder terminals short: 18.9 mm
- E: Solder terminals long: 22.6 mm
- E: Quick connect terminals 2.8x0.8 mm: 24.9 mm

Solder terminals for PCB

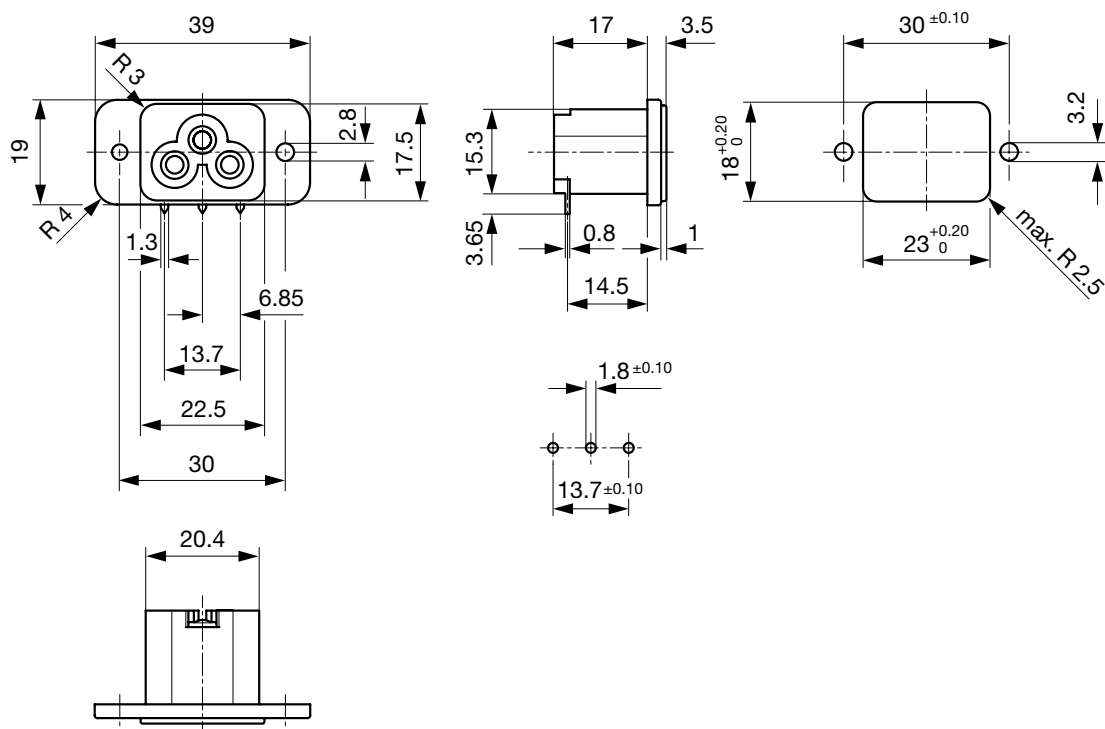

Config. Code





2562 - H - A B C 0 - D - E

The characters are placeholders for the correspondingly keys of selections from the key tables.

2562 - H - A B C 0 - D - E = Type

Type	Configuration key
protection class 1	X

2562 - H - A B C 0 - D - E = Terminals

Terminal L		Configuration key
short solder terminal (L = 4.8 mm)		2
long solder terminal (L = 8.5 mm)		3
PCB-terminal (standard)		4
Blade terminal (2.8 x 0.8 mm)		7

2562 - H - A B C 0 - D - E = Terminals

Terminal N	Configuration key
short solder terminal (L = 4.8 mm)	2

Symbols similar as in table A

Terminal N	Configuration key
long solder terminal (L = 8.5 mm)	3
PCB-terminal (standard)	4
Blade terminal (2.8 x 0.8 mm)	7

Symbols similar as in table A

2562 - H - A B C 0 - D - E = Terminals

Terminal Ground	Configuration key
PCB-terminal (standard)	4
Blade terminal (2.8 x 0.8 mm)	7

Symbols similar as in table A

2562 - H - A B C 0 - D - E = Color

Color	Configuration key
Black	A

2562 - H - A B C 0 - D - E = Style

Style	Configuration key
flange with through holes	2

All Variants

Config. Code	Description	Order Number
2562-4440-A-2	2562, IEC Appliance Inlet C6, 70°C, version: I, L: PCB-terminal (standard), N: PCB-terminal (standard), ground: PCB-terminal (standard), color: Black, design: flange with through holes	6160.0002

The listed variants should be available from stock Other versions on request www.schurter.com/contact

Availability for all products can be searched real-time: <http://www.schurter.com/en/Stock-Check/Stock-Check-SCHURTER>

Packaging unit 50 Pcs