

DC axial fans

DC axial fan overview	19
DC axial fans / DC diagonal fans	23



Technical information



Range of fans

ebm-papst offers you the widest full product line of DC axial and diagonal fans: From 25 mm to 280 mm in size. Every single type of fan can be optimally integrated in the respective device concept. The highly economical brushless motor technology of these fans provides a unique variety of intelligent innovations that can be realised today at prices that would have been unthinkable just a few years ago.



Electronic protection against reverse polarity

ebm-papst DC fans have electronically commutated drives with electronic protection against reverse polarity. The electronics are conveniently located in the fan hub.



Product life expectancy

A distinctive feature of DC fan technology is the convincingly high product life expectancy. Thanks to the excellent efficiency of the brushless drives, the thermal load of the bearings is reduced, thus considerably increasing the life expectancy of the fans.

Protection class

DC fans with sleeve and ball bearings are powered by Class E insulated motors. All ebm-papst fans conform to the requirements of protection class IP 20. Fans conforming to IP 54 and special protection classes are also available.

Voltage range

Many of our DC fans can be operated on voltages that are up to 50% lower and 25% higher than their nominal voltage (see Voltage range in the technical tables). This enables the air performance to be adapted to the cooling requirements and allows the noise to be reduced, even if the fan does not have a control input.

Closed-loop speed control and monitoring

Closed-loop speed control and function monitoring are becoming increasingly important in many applications. ebm-papst offers many fans in the standard design with a control input and open collector speed signal.

S-Force

The new S-Force fans with their extremely high blower capacity of up to 950 m³/h and pressure build-up of up to 1200 pascals are capable of dealing with the extreme heat load. If needed, these fans can produce up to 100% more output under full load and they work with a much broader delivery bandwidth than current models. This makes them ideal for equipment and systems with a high density of components. Thanks to intelligent motor features, they can be individually adapted for any application. S-Force fans are available in 5 standard dimensions.

Axial fans for DC operation

Overview of air performance

Dimensions	Series	Air flow	Air flow																			Page
			10	20	30	40	50	60	70	80	90	100	200	300	400	500	600	700	800	900	1000	
mm		m ³ /h																				
□ 25 x 8	250	2,1...4,5																				23
□ 40 x 10	400 F	6...9																				24
□ 40 x 20	400	10...13,5																				25
□ 40 x 25	400 J	19...24																				26
□ 50 x 15	500 F	11...20																				27
□ 60 x 15	600 F	19...33																				28
□ 60 x 25	620	21...67																				29
□ 60 x 25	630	40...44	NEW																			30
□ 60 x 25	600 N	21...56																				31
□ 60 x 25	600 N VARIOFAN	16...41																				32
□ 60 x 32	600 J	70...84	NEW																			33
□ 70 x 15	700 F	28...44																				34
□ 80 x 25	8450	33...118	NEW																			35
□ 80 x 25	8400 N	33...79																				36
□ 80 x 25	8400 N VARIOFAN	20...58																				37
□ 80 x 32	8300	32...80																				38
□ 80 x 38	8200 J	132...222																				39
□ 92 x 25	3400 N	61...102																				40
□ 92 x 25	3400 N VARIOFAN	44...84																				41
□ 92 x 32	3300	56...107																				42
□ 92 x 38	3200 J	130...280																				43
□ 119 x 25	4400 F	94...170																				44
□ 119 x 25	4400 FN	200...225																				45
□ 119 x 32	4300	95...204																				46
□ 119 x 32	4300 VARIOFAN	61...170																				47
□ 119 x 38	4400	150...285																				48
□ 119 x 38	4100 N	160...237																				49
□ 119 x 38	4100 NHH...NH6	260...440																				50
□ 119 x 38	4100 NH7...NH8	500...570																				51
□ 119 x 38	DV 4100	275																				52
□ 127 x 38	5200 N	187...338																				53
□ 127 x 38	DV 5200	270...324																				54
□ 135 x 38	5100 N	122...250																				55
□ 140 x 51	5300	338	NEW																			56
□ 140 x 51	5300 TD	410...670																				57
∅ 150 x 38	7100 N	360...420																				58
∅ 150 x 55	7200 N	360																				59
172x160x52	6100	350	NEW																			60
∅ 172 x 51	6300	395...545	NEW																			61
∅ 172 x 51	6300 TD	600...950	NEW																			62
172x160x51	6300 TD	710...950	NEW																			63
∅ 172 x 51	DV 6200	540																				64
∅ 172 x 51	DV 6200 TD	100...700																				65
172x150x51	6400	205...480																				66
172x150x51	6400 TD	90...900																				67
172x160x51	DV 6400	530																				68
172x160x51	DV 6400 TD	100...680																				69
220x200x51	2200 FTD	790...1220	NEW																			70
□ 225 x 80	W1G 200	1090																				71
□ 225 x 80	K1G 200	1020...1245	NEW																			72
□ 225 x 89	K3G 200	1215...1640	NEW																			73
□ 280 x 80	W1G 250	1920																				74



Optional special versions

Information on pictograms

On the pages of the catalogue and on the following overview pages, the pictograms illustrated below provide information about technically possible special versions in the fan line presented.

Please note that these special versions are not possible for all voltages and speeds, and not in all combinations.

The special versions are designed for specific customers and projects and are not usually available off the shelf.



Speed signal

The fan uses a separate wire to output information about its speed, and thus about the speed of the rotor. For technical details, please refer to page 110.



Go / No-go alarm

The fan uses a separate wire to output a static signal when it is stationary, thus providing information about whether or not the rotor is turning. For technical details, please refer to page 117.



Alarm with limit speed

If the speed drops below a certain level defined in the fan's electronics, the fan will emit a static signal, thus providing information about whether or not the rotor is turning. For technical details, please refer to page 114.



External temperature sensor

An NTC is connected to the fan via a separate wire and the fan changes its speed depending on the temperature at the NTC. For technical details, please refer to page 120.



Internal temperature sensor

In this case, the NTC is integrated into the fan and the fan changes its speed depending on the temperature at the NTC. For technical details, please refer to page 120.



PWM control input

The speed of the fan can be changed via a pulse-width-modulated signal. This signal is applied to a specially provided wire. For technical details, please refer to page 121.



Analogue control input

The speed of the fan can be changed via a control voltage. This control voltage is applied to a specially provided wire. For technical details, please refer to page 121.



Multi-option control input

The fan has a control input that the user can trigger either using a PWM signal, an analogue signal or a resistor. For technical details, please refer to page 122.



Protection against moisture

Protection for the fan's electronics against moisture and condensation. For technical details, please refer to page 123.



IP 54

Protection of motor and PCB board against splashed water and humidity. For technical details, please refer to page 123.



Protection against salt spray fog

Protection of fan against the damaging effects of salt spray fog. For technical details, please refer to page 123.

Axial fans for DC operation

Overview of technically feasible designs

Dimensions
VDE, UL, CSA
Sinter sleeve bearings/ball bearings
Sensor
Go / No-go alarm
Alarm with limit speed
External temperature sensor
Internal temperature sensor
PWM control input
Analogue control input
Multi-option control input
Humidity protection
IP >= IP54
Salt spray fog protection
Page

Axial fans		OPTIONAL														P.			
Series	mm																		
250	25 x 25 x 8	yes	□	●	-	-	-	-	-	-	-	-	-	-	-	●	-	-	23
400 F	40 x 40 x 10	yes	□	●	●	-	-	-	-	-	-	-	-	-	-	●	-	-	24
400	40 x 40 x 20	yes	□	●	●	-	-	-	-	-	-	-	-	-	-	●	-	-	25
400 J	40 x 40 x 25	yes	■	●	●	-	-	-	-	-	-	-	-	-	-	●	●	-	26
500 F	50 x 50 x 15	yes	□	●	●	-	-	-	-	-	-	-	-	-	-	●	-	-	27
600 F	60 x 60 x 15	yes	□	●	●	-	-	-	-	-	-	-	-	-	-	●	-	-	28
620	60 x 60 x 25	yes	■	●	●	●	●	●	●	●	●	-	-	-	-	●	●	-	29
NEW 630	60 x 60 x 25	yes	■	●	●	●	●	●	●	●	●	-	-	-	-	●	●	●	30
600 N	60 x 60 x 25	yes	□/■	●	●	-	-	-	-	-	-	-	-	-	-	●	●	-	31
600 N VARIOFAN	60 x 60 x 25	yes	□/■	●	●	-	-	-	-	-	-	-	-	-	-	●	-	-	32
NEW 600 J	60 x 60 x 32	yes	■	●	●	-	-	-	-	-	-	-	-	-	-	●	-	-	33
700 F	70 x 70 x 15	yes	□	●	●	-	-	-	-	-	-	-	-	-	-	●	-	-	34
NEW 8450	80 x 80 x 25	yes	■	●	●	-	-	-	-	-	-	-	-	-	-	●	-	-	35
8400 N	80 x 80 x 25	yes	□/■	●	●	●	●	●	●	●	●	-	-	-	-	●	●	-	36
8400 N VARIOFAN	80 x 80 x 25	yes	□	●	●	-	-	-	-	-	-	-	-	-	-	●	-	-	37
8300	80 x 80 x 32	yes	□/■	●	●	●	●	●	●	●	●	-	-	-	-	●	●	●	38
8200 J S-Force	80 x 80 x 38	yes	■	●	●	●	●	●	●	●	●	-	-	-	-	●	-	-	39
3400 N	92 x 92 x 25	yes	□/■	●	●	●	●	●	●	●	●	-	-	-	-	●	●	-	40
3400 N VARIOFAN	92 x 92 x 25	yes	■	●	●	-	-	-	-	-	-	-	-	-	-	●	-	-	41
3300	92 x 92 x 32	yes	□/■	●	●	●	●	●	●	●	●	-	-	-	-	●	●	●	42
3200 J	92 x 92 x 38	yes	■	●	●	●	●	●	●	●	●	-	-	-	-	●	●	-	43
4400 F	119 x 119 x 25	yes	□/■	●	●	●	●	●	●	●	●	-	-	-	-	●	-	-	44
4400 FN	119 x 119 x 25	yes	■	●	●	●	●	●	●	●	●	-	-	-	-	●	-	-	45
4300	119 x 119 x 32	yes	□/■	●	●	●	●	●	●	●	●	-	-	-	-	●	●	●	46
4300 VARIOFAN	119 x 119 x 32	yes	■	●	●	●	●	●	●	●	●	-	-	-	-	●	-	-	47
4400	119 x 119 x 38	yes	■	●	●	●	●	●	●	●	●	-	-	-	-	●	-	-	48
4100 N	119 x 119 x 38	yes	□/■	●	●	●	●	●	●	●	●	-	-	-	-	●	●	●	49
4100 NH...NH6	119 x 119 x 38	yes	■	●	●	●	●	●	●	●	●	-	-	-	-	●	-	-	50
4100 NH7...NH8	119 x 119 x 38	yes	■	●	●	●	●	●	●	●	●	-	-	-	-	●	-	-	51
DV 4100	119 x 119 x 38	yes	■	●	●	●	●	●	●	●	●	-	-	-	-	●	●	●	52
5200 N	127 x 127 x 38	yes	■	●	●	●	●	●	●	●	●	-	-	-	-	●	●	●	53
DV 5200	127 x 127 x 38	yes	■	●	●	●	●	●	●	●	●	-	-	-	-	●	●	●	54
5100 N	135 x 135 x 38	yes	■	●	●	●	●	●	●	●	●	-	-	-	-	●	●	●	55
NEW 5300 S-Force	140 x 140 x 51	yes	■	●	●	●	●	●	●	●	●	-	-	-	-	●	●	●	56
5300 TDS-Force	140 x 140 x 51	yes	■	●	●	●	●	●	●	●	●	-	-	-	-	●	-	-	57
7100 N	150 Ø x 38	yes	■	●	●	●	●	●	●	●	●	-	-	-	-	●	●	●	58
7200 N	150 Ø x 55	yes	■	●	●	●	●	●	●	●	●	-	-	-	-	●	●	●	59
NEW 6100 N	172 x 160 x 51	yes	■	●	●	●	●	●	●	●	●	-	-	-	-	●	●	●	60
NEW 6300 S-Force	172 Ø x 51	yes	■	●	●	●	●	●	●	●	●	-	-	-	-	●	●	●	61
NEW 6300 TDS-Force	172 Ø x 51	yes	■	●	●	●	●	●	●	●	●	-	-	-	-	●	●	●	62
NEW 6300 TDS-Force	172 x 160 x 51	yes	■	●	●	●	●	●	●	●	●	-	-	-	-	●	●	●	63
DV 6200	172 Ø x 51	yes	■	●	●	●	●	●	●	●	●	-	-	-	-	●	●	●	64
DV 6200 TD	172 Ø x 51	yes	■	●	●	●	●	●	●	●	●	-	-	-	-	●	●	●	65
6400	172 x 150 x 51	yes	■	●	●	●	●	●	●	●	●	-	-	-	-	●	●	●	66
6400 TD	172 x 150 x 51	yes	■	●	●	●	●	●	●	●	●	-	-	-	-	●	●	●	67
DV 6400	172 x 160 x 51	yes	■	●	●	●	●	●	●	●	●	-	-	-	-	●	●	●	68
DV 6400 TD	172 x 160 x 51	yes	■	●	●	●	●	●	●	●	●	-	-	-	-	●	●	●	69
NEW 2200 FTD	200 Ø x 51	yes	■	●	●	●	●	●	●	●	●	-	-	-	-	●	●	●	70
W1G 200	225 x 225 x 80	UL/CSA	■	●	●	●	●	●	●	●	●	-	-	-	-	●	-	●	71
NEW K1G 200	225 x 225 x 80	yes	■	●	●	●	●	●	●	●	●	-	-	-	-	●	-	●	72
NEW K3G 200	225 x 225 x 89	yes	■	●	●	●	●	●	●	●	●	-	-	-	-	●	-	●	73
W1G 250	280 x 280 x 80	UL/CSA	■	●	●	●	●	●	●	●	●	-	-	-	-	●	-	●	74

Please note that these special versions are not possible for all voltages and speeds, and not in all combinations. The special versions are designed for specific customers and projects. As a rule they are not available off the shelf and are tied to minimum volumes. Please consult your customer support representative about the feasibility of your special variant.

* approvals applied for
 - not yet available
 ● available
 □ Sleeve bearings
 ■ Ball bearings

Connection instructions for S-Force fans

Special features of S-Force fans

The S-Force series is the most powerful product series on the market. S-Force stands for the highest innovation in motor technology, fluid mechanics and electronics. The one-of-a-kind power density of the products requires special attention to the application at the customer's facility.

Service life

Due to the high currents in the fans, the load on the electrolyte capacitor is greater, which reduces the service life of the capacitor. As a larger or additional capacitor cannot be housed in the fan, the capacitor must be housed in the supply line.

If the power pack of the application has a corresponding capacitor, in some cases it may be possible to omit the external capacitor.

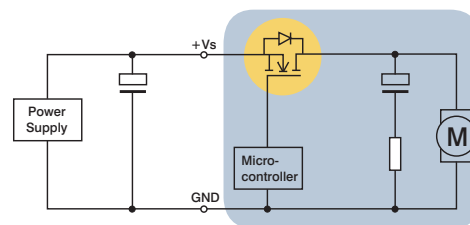

Recommended measure: Additional external capacitor (thus must be installed as close to the fan as possible < 30 cm).

Fan	Capacitor required
S-Force axial	
8200 / 3200 JH3-JH4	no
4100 NH3 / NH4 / NH5 / NH6	no
4100 NH7 / NH8	yes
5300 / 5300 TD	no
6300 / 6300 TD	no
2200 FTD	no
S-Force centrifugal	
RET 97 TD	yes
RER 120 TD	yes
RER 133 TD	no
RER 160 NTDHH	yes
REF 175 TD	no
RER 175 TD	no
RER 190 TD / RG 190 TD	no
RER 220 TD / RG 220	no
RER 225 TDM / RG 225 TDM	no
RER 225 TD / RG 225 TD	yes

Recommended capacitors

We recommend using the following capacitors from Rubycon:

24 VDC:

50 ZL 680 μ F; 12,5 mm x 30 mm or

50 ZLH 680 μ F 12,5 mm x 30 mm

48 VDC:

100 YXG 470 μ F; 16 mm x 35,5 mm or

100 ZLH 470 μ F 16 mm x 31,5 mm

Other capacitors with equal or greater capacitance and equal or lower serial resistance can also be used.

ebm-papst St. Georgen offers the following capacitors ex stock:

24 VDC: 1000 μ F / 50 V, 16 mm x 25 mm

Art. No.: 992 0345 000 (LZ 354)

48 VDC: 680 μ F / 100 V, 18 mm x 40 mm

Art. No. : 992 0355 000 (LZ 355)

max. 4,5 m³/h

DC axial fans

Series 250 25 x 25 x 8 mm

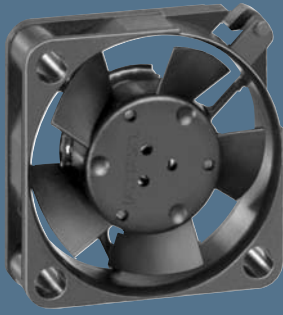

Highlights:

- Compact fan with low power consumption.

General characteristics:

- Material: fibreglass-reinforced plastic. Impeller PA, housing PBT.
- Fully integrated electronic commutation.
- Protected against reverse polarity and locking.
- Connection via single strands AWG 28, TR 64. Bared and tin-plated.
- Air exhaust over struts. Direction of rotation counter-clockwise, seen on rotor.
- Mass: 5 g.

Nominal data		Air flow	Air flow	Nominal voltage	Voltage range	Sound pressure level	Sound power level	Sinter sleeve bearings Ball bearings	Power input	Nominal speed	Temperature range	Service life L ₁₀ (20 °C) ebm-papst Standard	Service life L ₁₀ (60 °C) ebm-papst Standard	Life expectancy L ₁₀ ^Δ (40 °C) see P. 15	Curve	Specials
Type		m ³ /h	CFM	VDC	VDC	dB(A)	Bel(A)	□ / ■	Watts	RPM	°C	Hours	Hours	Hours	P. 110	
255 M		2,1	1,2	5	4,5...5,5	5	< 3	□	0,2	6 000	-10...+70	45 000 / 14 000	45 000	1		
255 N		3,2	1,9	5	4,5...5,5	16	< 3	□	0,4	9 600	-10...+70	40 000 / 12 000	40 000	2	/2	
255 H		4,5	2,6	5	4,5...5,5	23	4,4	□	0,6	12 000	-10...+55	35 000 / 12 000*	30 000	3	/2	
252 N		3,2	1,9	12	10...14	15	< 3	□	0,5	9 000	-10...+70	40 000 / 12 000	40 000	2	/2	
252 H		4,5	2,6	12	10...14	23	4,4	□	0,7	12 000	-10...+55	35 000 / 12 000*	30 000	3		

* at 55 °C

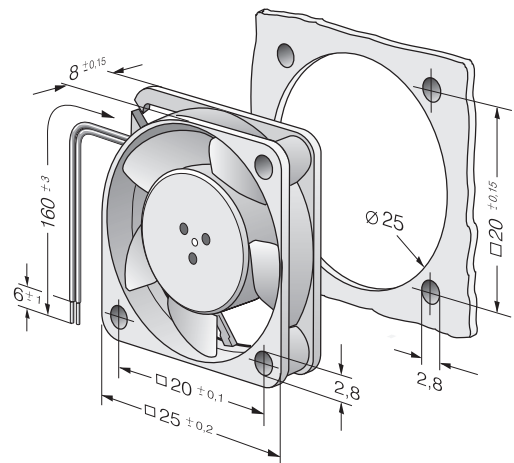
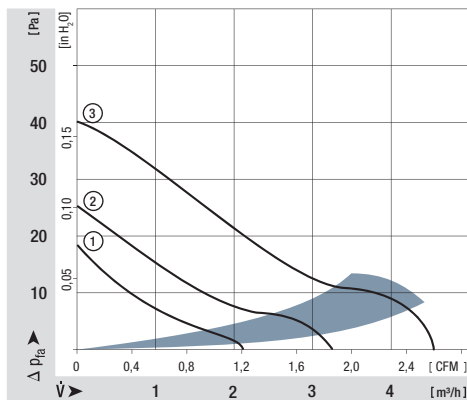

max. 9 m³/h

DC axial fans

Series 400 F 40 x 40 x 10 mm



Highlights:

- Compact fan with low power consumption.
- Some models suitable for use at high ambient temperatures.

General characteristics:

- Material: fibreglass-reinforced plastic. impeller PA, housing PBT.
- Fully integrated electronic commutation.
- Protected against reverse polarity and locking.
- Connection via single strands AWG 28, TR 64. Bared and tin-plated.
- Air exhaust over struts. Direction of rotation counter-clockwise, seen on rotor.
- Mass: 17 g.

Nominal data	Air flow		Nominal voltage	Voltage range	Sound pressure level	Sound power level	Sinter sleeve bearings Ball bearings	Power input	Nominal speed	Temperature range	Service life L ₁₀ (20 °C) ebm-papst Standard	Service life (60 °C) ebm-papst Standard	Life expectancy L ₁₀ ^Δ (40 °C), see P. 15	Curve	Specials
	m ³ /h	CFM													
405 F	8	4,7	5	4,5...5,5	22,1	4,4	□	0,7	5 400	-20...+70	45 000 / 15 000	47 500	2	/2	
405 FH	9	5,3	5	4,5...5,5	26,0	4,6	■	0,9	6 000	-20...+70	45 000 / 15 000	47 500	3	/2	
412 FM	6	3,5	12	10...14	16,5	3,8	■	0,6	4 300	-20...+70	45 000 / 15 000	47 500	1		
412 F	8	4,7	12	10...14	22,1	4,4	■	0,7	5 400	-20...+70	45 000 / 15 000	47 500	2		
412 FH	9	5,3	12	10...14	26,0	4,6	■	0,8	6 000	-20...+70	45 000 / 15 000	47 500	3	/2	
414 F	8	4,7	24	20...28	22,1	4,4	■	0,8	5 400	-20...+70	45 000 / 15 000	47 500	2	/2	
414 FH	9	5,3	24	21,6...26,4	26,0	4,4	■	0,9	6 000	-20...+70	45 000 / 15 000	47 500	3		
Models with temperature range up to +85 °C.															
412 FM-074	6	3,5	12	10...14	16,5	3,8	■	0,4	4 300	-20...+85	45 000 / 15 000	47 500	1	/2	
412 F-130	8	4,7	12	10...14	22,1	4,4	■	0,6	5 400	-20...+85	45 000 / 15 000	47 500	2		
412 FH-132	9	5,3	12	10...14	26,0	4,6	■	0,7	6 000	-20...+85	45 000 / 15 000	47 500	3	/2	

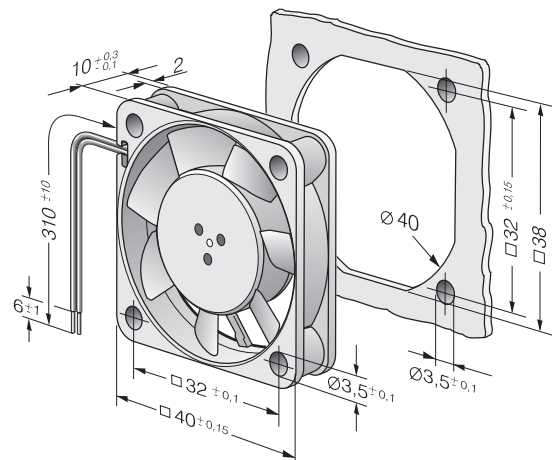
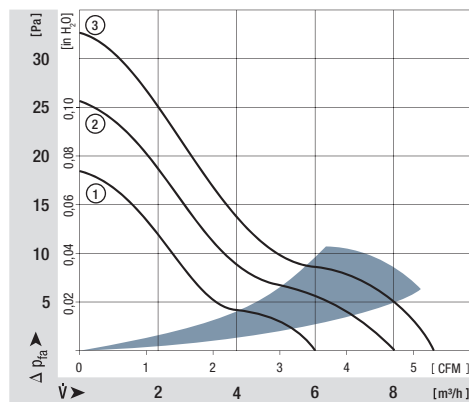

max. 13,5 m³/h

DC axial fans

Series 400 40 x 40 x 20 mm



Highlights:

- Compact fan with low power consumption.
- Some models suitable for use at high ambient temperatures.

General characteristics:

- Material: fibreglass-reinforced plastic. Impeller PA, housing PBT.
- Fully integrated electronic commutation.
- Protected against reverse polarity and locking.
- Connection via single strands AWG 28, TR 64. Bared and tin-plated.
- Air exhaust over struts. Direction of rotation counter-clockwise, seen on rotor.
- Mass: 27 g.

Nominal data		Air flow	Air flow	Nominal voltage	Voltage range	Sound pressure level	Sound power level	Sinter sleeve bearings Ball bearings	Power input	Nominal speed	Temperature range	Service life L ₁₀ (20 °C) ebm-papst Standard	Service life (60 °C) ebm-papst Standard	Life expectancy L ₁₀ ^Δ (40 °C) see P. 15	Curve	Specials
Type		m ³ /h	CFM	VDC	VDC	dB(A)	Bel(A)	□ / ■	Watts	RPM	°C	Hours	Hours		P. 110/118	
405		10,0	5,9	5	4,5...5,5	18	3,8	□	0,9	6 000	-20...+70	50 000 / 20 000	62 500	1	/2	
412		10,0	5,9	12	10...14	18	3,8	□	0,9	6 000	-20...+70	50 000 / 20 000	62 500	1	/2	
412 H		13,5	7,9	12	10...14	29	4,7	□	1,6	8 100	-20...+60	45 000 / 15 000	47 500	2	/39	
414		10,0	5,9	24	20...28	18	3,8	□	1,0	6 000	-20...+70	50 000 / 20 000	62 500	1	/2	
414 H		13,5	7,9	24	20...26,5	29	4,7	□	1,6	8 100	-20...+60	45 000 / 15 000	47 500	2	/2	
Model with temperature range up to +85 °C.																
412-099		10,0	5,9	12	10...14	18	3,8	□	0,8	6 000	-20...+85	50 000 / 20 000	62 500	1		

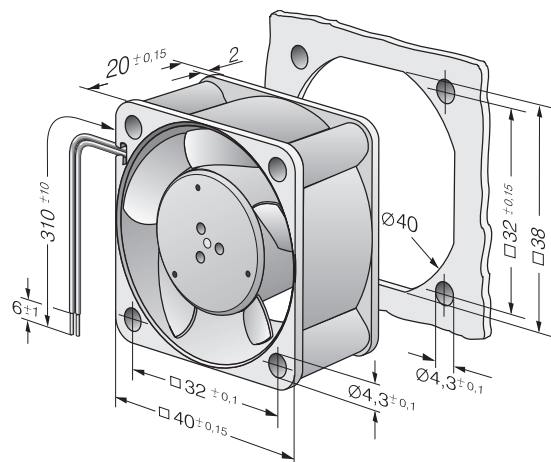
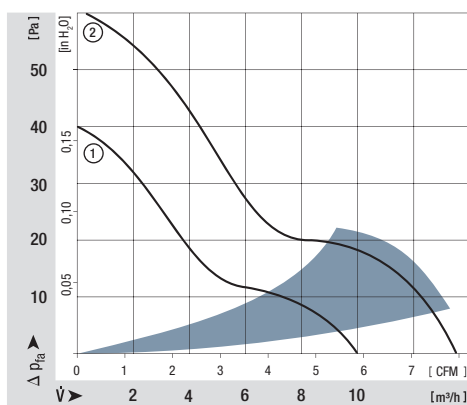

max. 24 m³/h

DC axial fans

Series 400 J 40 x 40 x 25 mm



Highlights:

- Very rigid compression curve for high air flow at high back pressure.
- Low operating noise level at high back pressure.

General characteristics:

- Material: fibreglass-reinforced plastic. Impeller PA, housing PBT.
- Fully integrated electronic commutation.
- Protected against reverse polarity and locking.
- Connection via single strands AWG 26, TR 64. Bared and tin-plated.
- Air exhaust over struts. Direction of rotation counter-clockwise, seen on rotor.
- Mass: 50 g.

Nominal data	Air flow		Nominal voltage	Voltage range	Sound pressure level	Sound power level	Sinter sleeve bearings Ball bearings	Power input	Nominal speed	Temperature range	Service life L ₁₀ (40 °C) ebm-papst Standard	Service life L ₁₀ (T _{max}) ebm-papst Standard	Life expectancy L ₁₀ ^Δ (40 °C) see P. 15	Curve	Specials
	m ³ /h	CFM													
412 J	19	11,2	12	8...14	39	5,5	■	2,4	10 300	-20...+70	60 000 / 30 000	120 000	1		
412 JH	22	12,9	12	8...13,5	43	5,8	■	3,0	11 700	-20...+70	60 000 / 30 000	120 000	2	/2	
412 JHH	24	14,1	12	8...13,5	46	6,1	■	3,3	13 000	-20...+60	57 500 / 35 000	110 000	3	/2	
414 J	19	11,2	24	18...27	39	5,5	■	2,4	10 300	-20...+70	60 000 / 30 000	120 000	1		
414 JH	22	12,9	24	18...27	43	5,8	■	3,0	11 700	-20...+70	60 000 / 30 000	120 000	2	/2	
414 JHH	24	14,1	24	18...27	46	6,1	■	3,6	13 000	-20...+60	57 500 / 35 000	110 000	3	/2	

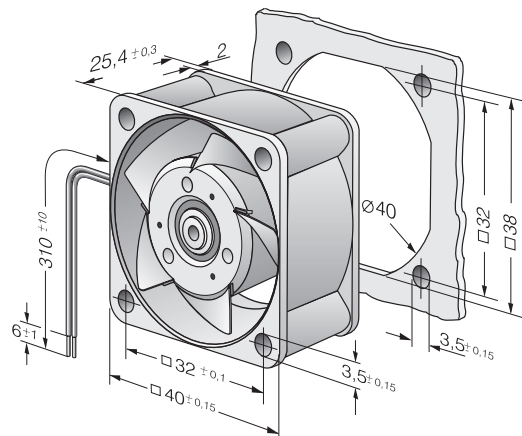
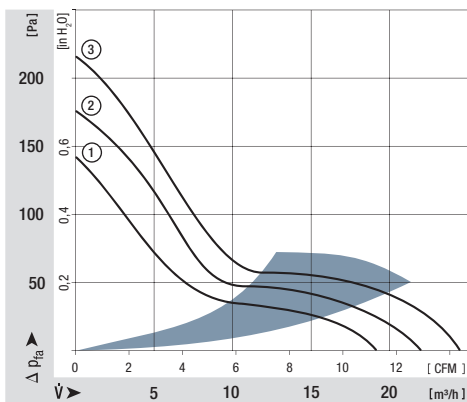

max. 20 m³/h

DC axial fans

Series 500 F 50 x 50 x 15 mm



Highlights:

- Compact fan with low power consumption.
- Some models suitable for use at high ambient temperatures.

General characteristics:

- Material: fibreglass-reinforced plastic. Impeller PA, housing PBT.
- Fully integrated electronic commutation.
- Protected against reverse polarity and locking.
- Connection via single strands AWG 28, TR 64. Bared and tin-plated.
- Air exhaust over struts. Direction of rotation counter-clockwise, seen on rotor.
- Mass: 25 g.

Nominal data		Air flow	Air flow	Nominal voltage	Voltage range	Sound pressure level	Sound power level	Sinter sleeve bearings Ball bearings	Power input	Nominal speed	Temperature range	Service life L ₁₀ (20 °C) ebm-papst Standard	Service life L ₁₀ (60 °C) ebm-papst Standard	Life expectancy L ₁₀ Δ (40 °C) see P. 15	Curve	Specials
Type	m ³ /h	CFM	VDC	VDC	dB(A)	Bel(A)	□ / ■	Watts	RPM	°C	Hours	Hours	Hours	P. 110		
512 F	20	11,8	12	10,8...13,2	30	4,5	□	1,0	5 000	-20...+70	50 000 / 20 000	62 500	2	/2		
514 F	20	11,8	24	21,6...26,4	30	4,5	□	1,0	5 000	-20...+70	50 000 / 20 000	62 500	2	/2		
Model with temperature range up to +85 °C.																
512 FL-547	11	6,5	12	11,5...13,2	12	3,7	□	0,4	3 000	-20...+85	50 000 / 20 000	65 500	1			
512 F-532	20	11,8	12	10,8...13,2	30	4,5	□	0,9	5 000	-20...+85	50 000 / 20 000	65 500	2			

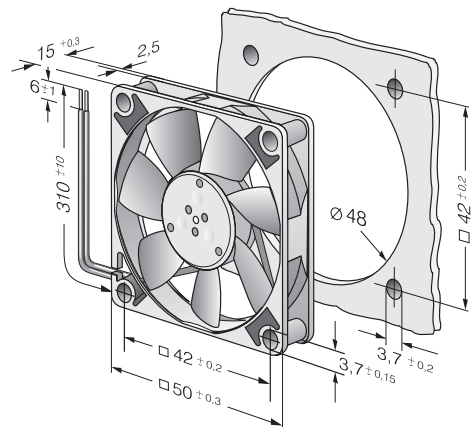
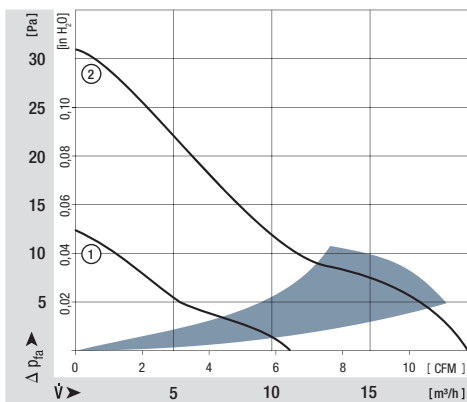

max. 33 m³/h

DC axial fans

Series 600 F 60 x 60 x 15 mm



Highlights:

- Compact fan with low power consumption.
- Some models suitable for use at high ambient temperatures.

General characteristics:

- Material: fibreglass-reinforced plastic. Impeller PA, housing PBT.
- Fully integrated electronic commutation.
- Protected against reverse polarity and locking.
- Connection via single strands AWG 28, TR 64. Bared and tin-plated.
- Air exhaust over struts. Direction of rotation counter-clockwise, seen on rotor.
- Mass: 30 g.

Nominal data	Air flow		Nominal voltage	Voltage range	Sound pressure level	Sound power level	Sinter sleeve bearings Ball bearings	Power input	Nominal speed	Temperature range	Service life L ₁₀ (20 °C) ebm-papst Standard	Service life L ₁₀ (60 °C) ebm-papst Standard	Life expectancy L ₁₀ Δ (40 °C) see P. 15	Curve	Specials
	m ³ /h	CFM													
605 F	29	17,1	5	4,5...5,2	27	4,4	□	1,1	4 000	-20...+50	50 000 / 20 000	50 000	2	/2	
612 FL	19	11,2	12	11,5...13,2	16	3,6	□	0,4	2 650	0...+70	50 000 / 20 000	62 500	1		
612 F	29	17,1	12	10,8...13,2	27	4,4	□	1,0	3 900	-20...+70	50 000 / 20 000	62 500	2	/2	
612 FH	33	19,4	12	10,0...13,2	31	4,8	□	1,4	4 500	-20...+60	45 000 / 15 000	47 500	3	/2/39	
614 F	29	17,1	24	21,6...26,4	27	4,4	□	1,1	3 900	-20...+70	50 000 / 20 000	62 500	2	/2	
Models with temperature range up to +80 / 85 °C.															
612 FL-680	19	11,2	12	11,5...14	16	3,6	□	0,5	2 650	-20...+85	50 000 / 20 000	62 500	1		
612 F-637	29	17,1	12	10,8...12,6	27	4,4	□	1,0	3 900	-20...+80	50 000 / 20 000	62 500	2		

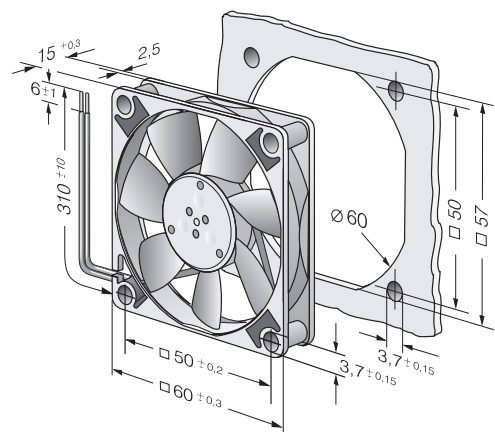
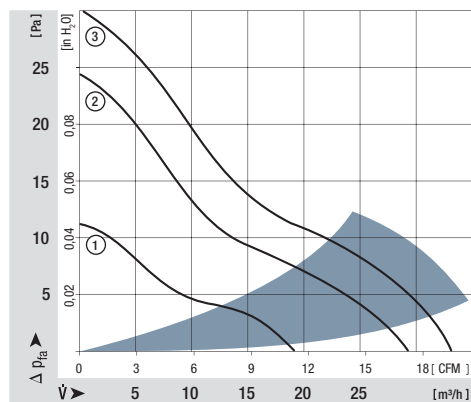

max. 67 m³/h

DC axial fans

Series 620 60 x 60 x 25 mm



Highlights:

- Very rigid compression curve for high air flow at high back pressure.
- Motor with very low structure-borne noise.
- Innovative impeller with winglets for low noise.
- Control inputs, alarm and speed signals available on request.

General characteristics:

- Material: fibreglass-reinforced plastic. Impeller PA, housing PBT.
- Fully integrated electronic commutation.
- Protected against reverse polarity and locking.
- Connection via single strands AWG 22, TR 64. Bared and tin-plated.
- Air exhaust over struts. Direction of rotation clockwise, seen on rotor.
- Mass: 85 g.

Nominal data		Air flow	Air flow	Nominal voltage	Voltage range	Sound pressure level	Sound power level	Sinter sleeve bearings Ball bearings	Power input	Nominal speed	Temperature range	Service life L ₁₀ (40 °C) ebm-papst Standard	Service life L ₁₀ (T _{max}) ebm-papst Standard	Life expectancy L ₁₀ Δ (40 °C) see P. 15	Curve	Specials
Type		m ³ /h	CFM	VDC	VDC	dB(A)	Bel(A)	■ / ■	Watts	RPM	°C	Hours	Hours	Hours	P. 110	
622 L		21	12,4	12	8...15	20	3,7	■	0,5	3 200	-20...+85	80 000 / 20 000	160 000	1		
622 M		30	17,7	12	8...15	29	4,3	■	1,0	4 550	-20...+75	77 500 / 30 000	150 000	2		
622 N		40	23,5	12	8...15	35	4,7	■	1,9	6 100	-20...+70	72 500 / 35 000	140 000	3	/2	
622 H		46	27,1	12	8...15	39	5,1	■	2,3	6 850	-20...+70	70 000 / 35 000	140 000	4		
622 HH		56	33,0	12	8...15	43	5,6	■	3,5	8 200	-20...+70	65 000 / 32 500	130 000	5		
NEW 622 /2H3P		67	39,4	12	8...13,2	48	5,9	■	6,3	9 700	-20...+60	52 500 / 32 500	105 000	6		
624 L		21	12,4	24	18...28	20	3,7	■	1,0	3 200	-20...+70	80 000 / 40 000	160 000	1		
624 M		30	17,7	24	12...28	29	4,3	■	1,5	4 550	-20...+70	77 500 / 37 500	150 000	2		
624 N		40	23,5	24	12...28	35	4,7	■	2,2	6 100	-20...+70	72 500 / 35 000	140 000	3		
624 H		46	27,1	24	18...28	39	5,1	■	2,4	6 850	-20...+70	70 000 / 35 000	140 000	4		
624 HH		56	33,0	24	18...28	43	5,6	■	3,6	8 200	-20...+70	65 000 / 32 500	130 000	5	/2	
NEW 624 /2H3P		67	39,4	24	18...28	48	5,9	■	5,8	9 700	-20...+60	52 500 / 32 500	105 000	6		
628 HH		56	33,0	48	36...56	43	5,6	■	4,2	8 200	-20...+70	65 000 / 32 500	130 000	5	/2	

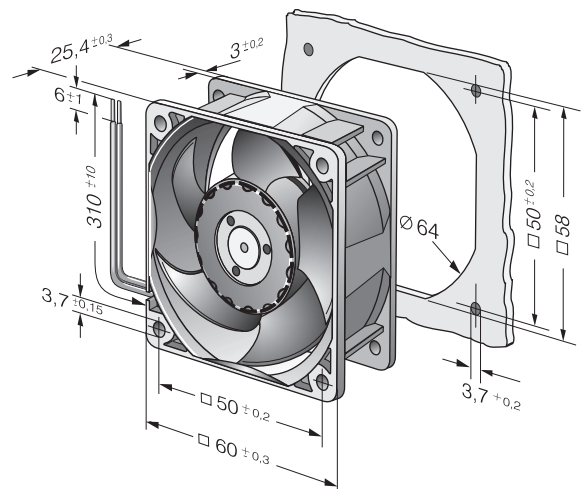
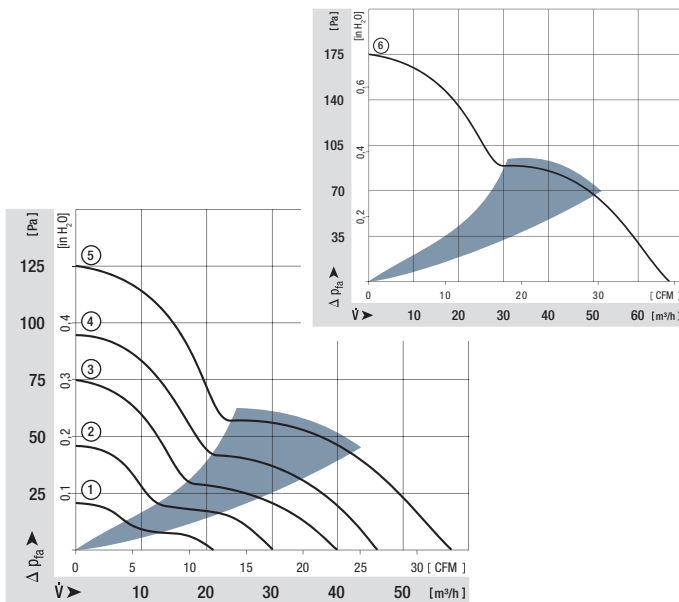

max. 44 m³/h

DC axial fans

Series 630 60 x 60 x 25 mm

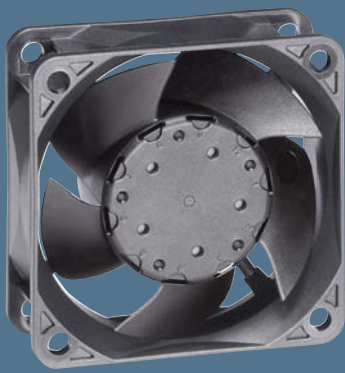

Highlights:

- Very rigid compression curve for high air flow at high back pressure.
- Motor with very low structure-borne noise.
- Control inputs, alarm and speed signals available on request.
- Developed for applications with stringent environmental requirements.

General characteristics:

- Material: fibreglass-reinforced plastic. Impeller PA, housing PBT.
- Fully integrated electronic commutation.
- Protected against reverse polarity and locking.
- Connection via single strands AWG 22, TR 64. Bared and tin-plated.
- Air exhaust over struts. Direction of rotation clockwise, seen on rotor.
- Mass: 70 g.

Nominal data		Air flow	Air flow	Nominal voltage	Voltage range	Sound pressure level	Sound power level	Sinter sleeve bearings Ball bearings	Power input	Nominal speed	Temperature range	Service life L ₁₀ (40 °C) ebm-papst Standard	Service life L ₁₀ (T _{max}) ebm-papst Standard	Life expectancy L ₁₀ ^Δ (40 °C) see P. 15	Curve	Specials
Type		m ³ /h	CFM	VDC	VDC	dB(A)	Bel(A)	■ / ■	Watts	RPM	°C	Hours	Hours	Hours		
NEW	632 NU	40	23,5	12	6...15	33	5,2	■	1,8	5 900	-20...+70	85 000 / 42 500	170 000	1		
NEW	632 /2HPU	44	25,9	12	10,8...13,2	35	5,4	■	1,5	6 400	-20...+70	85 000 / 42 500	170 000	2		
NEW	638 /2HPU	44	25,9	48	40...60	35	5,4	■	1,8	6 400	-20...+70	85 000 / 42 500	170 000	2		

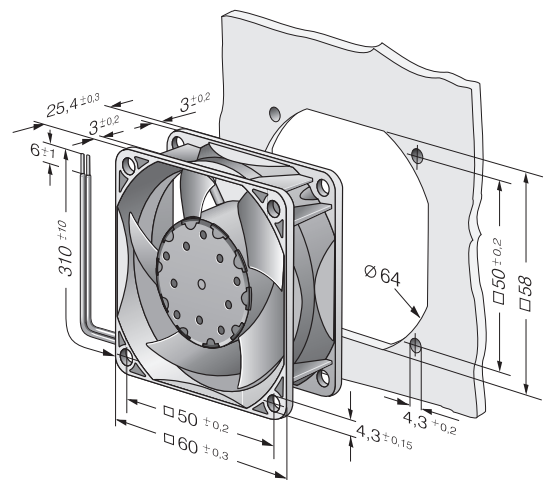
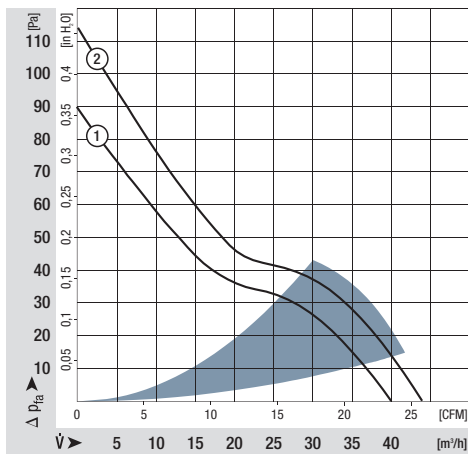

max. 56 m³/h

DC axial fans

Series 600 N 60 x 60 x 25 mm

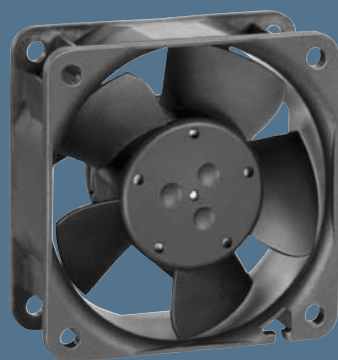

Highlights:

- Ball bearings and sleeve bearings available.
- Some models suitable for use at high ambient temperatures up to 85 °C.

General characteristics:

- Material: fibreglass-reinforced plastic. Impeller PA, housing PBT.
- Fully integrated electronic commutation.
- Protected against reverse polarity and locking.
- Connection via single strands AWG 22, TR 64. Bared and tin-plated.
- Air exhaust over struts. Direction of rotation clockwise, seen on rotor.
- Mass: 66 g.

Nominal data	Air flow		Nominal voltage	Voltage range	Sound pressure level	Sound power level	Sinter sleeve bearings Ball bearings	Power input	Nominal speed	Temperature range	Service life L ₁₀ (40 °C) ebm-papst Standard	Service life L ₁₀ (T _{max}) ebm-papst Standard	Life expectancy L ₁₀ Δ (40 °C) see P. 15	Curve	Specials
	Type	m ³ /h													
612 NGL	21	12,4	12	8...15	16	3,6	□	0,6	2 500	-20...+85	80 000 / 27 500	160 000	1		
612 NLE	21	12,4	12	8...15	16	3,6	■	0,4	2 500	-20...+85	80 000 / 27 500	160 000	1		
612 NGMLE	25	14,7	12	8...15	19	3,9	□	0,7	3 000	-20...+80	80 000 / 32 500	160 000	2		
612 NMLE	25	14,7	12	8...15	19	3,9	■	0,4	3 000	-20...+85	80 000 / 27 500	160 000	2		
612 NGME	35	20,6	12	8...15	28	4,6	□	1,2	4 100	-20...+75	80 000 / 35 000	160 000	3		
612 NME	35	20,6	12	8...15	28	4,6	■	0,8	4 100	-20...+75	80 000 / 35 000	160 000	3	/2	
612 NN	42	24,7	12	8...15	35	5,0	■	1,6	5 100	-20...+70	70 000 / 35 000	140 000	4		
612 NH	46	27,1	12	8...15	37	5,3	■	2,0	5 600	-20...+70	70 000 / 35 000	140 000	5	/2	
612 NHH-118	56	33,0	12	8...15	41	5,7	■	2,9	6 800	-20...+70	60 000 / 30 000	120 000	6	/2	
614 NGL	21	12,4	24	18...28	16	3,6	□	1,0	2 500	-20...+70	80 000 / 40 000	160 000	1		
614 NL	21	12,4	24	18...28	16	3,6	■	0,9	2 500	-20...+70	80 000 / 40 000	160 000	1	/2	
614 NGML	25	14,7	24	18...28	19	3,9	□	1,2	3 000	-20...+70	80 000 / 40 000	160 000	2	/2	
614 NML	25	14,7	24	18...28	19	3,9	■	1,0	3 000	-20...+70	80 000 / 40 000	160 000	2		
614 NGM	35	20,6	24	18...28	28	4,6	□	1,7	4 100	-20...+70	80 000 / 40 000	160 000	3	/12	
614 NM	35	20,6	24	18...28	28	4,6	■	1,4	4 100	-20...+70	80 000 / 40 000	160 000	3	/2/39	
614 NN	42	24,7	24	18...28	35	5,0	■	1,8	5 100	-20...+70	70 000 / 35 000	140 000	4		
614 NH	46	27,1	24	18...26	37	5,3	■	2,1	5 600	-20...+70	70 000 / 35 000	140 000	5	/2	
614 NHH	56	33,0	24	18...26	41	5,7	■	3,0	6 850	-20...+70	60 000 / 30 000	120 000	6		
614 NHH-119	56	33,0	24	18...28	41	5,7	■	3,0	6 850	-20...+70	60 000 / 30 000	120 000	6	/2	
618 NM	35	20,6	48	36...56	28	4,6	■	1,4	4 100	-20...+70	80 000 / 40 000	160 000	3		
618 NN	42	24,7	48	36...56	35	5,0	■	2,1	5 100	-20...+65	70 000 / 40 000	140 000	4	/2/12/39	

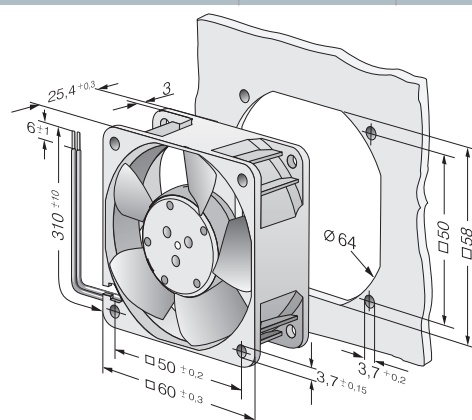
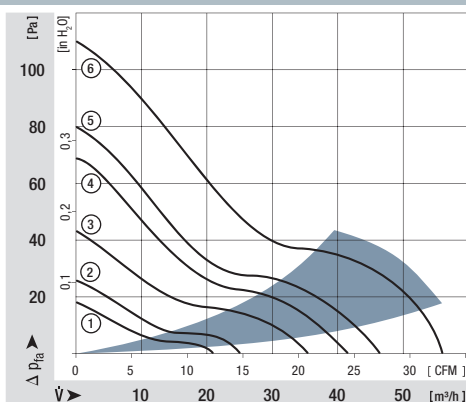

max. 41 m³/h

DC axial fans

Series 600 N VARIOFAN 60 x 60 x 25 mm



Highlights:

- Open loop speed control by means of external or internal temperature sensor.
- Automatic speed adjustment according to cooling requirements.

General characteristics:

- Material: fibreglass-reinforced plastic. Impeller PA, housing PBT.
- Fully integrated electronic commutation.
- Protected against reverse polarity and locking.
- Connection via single strands AWG 22, TR 64. Bared and tin-plated.
- Air exhaust over struts. Direction of rotation clockwise, seen on rotor.
- Mass: 66 g.

Nominal data		Air flow		Nominal voltage	Voltage range	Sound pressure level	Sound power level	Sinter sleeve bearings Ball bearings	Power input	Nominal speed	Temperature range	Service life L ₁₀ (40 °C) ebm-papst Standard	Service life L ₁₀ (T _{max}) ebm-papst Standard	Life expectancy L ₁₀ Δ (40 °C) see P. 15	Curve	Specials
Type	m ³ /h	CFM	VDC	VDC	dB(A)	Bel(A)	□ / ■	Watts	RPM	°C	Hours	Hours	Hours			
30°C 55°C	612 NGMI	18 35	10,6 20,6	12	8...12,6	14 28	3,5 4,6	□	1,3 1,7	2 150 4 100	-20...+65	80 000 / 45 000	160 000	1 2		
30°C 55°C	612 NMI	16 35	9,4 20,6	12	8...12,6	16 28	3,6 4,6	■	1,0 1,4	2 400 4 100	-20...+65	80 000 / 45 000	160 000	3 4		
30°C 55°C	612 NGNI	23 41	13,5 24,1	12	8...12,6	18 35	3,8 5,0	□	1,7 2,4	2 900 5 100	-20...+65	70 000 / 40 000	142 500	5 6		
30°C 55°C	612 NNI	23 41	13,5 24,1	12	8...12,6	18 35	3,8 5,0	■	1,2 1,5	2 900 5 100	-20...+65	70 000 / 40 000	142 500	5 6		
30°C 55°C	612 NGNV	23 41	13,5 24,1	12	8...12,6	18 35	3,8 5,0	□	1,7 2,4	2 900 5 100	-20...+65	70 000 / 40 000	142 500	5 6		

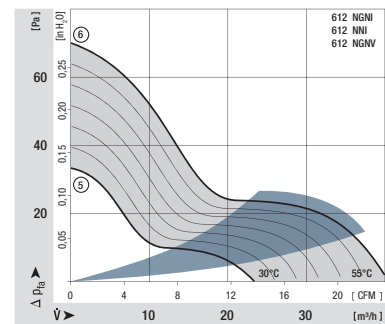
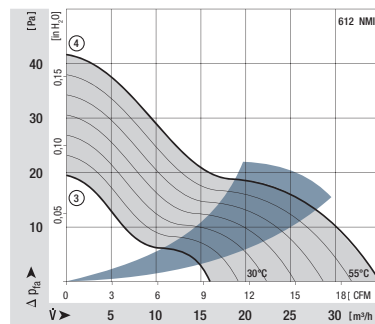
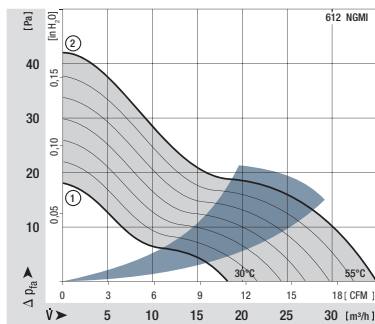

V-Types

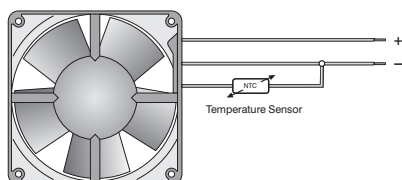

The temperature sensor for controlling the motor speed is not included in delivery.
Temperature sensor LZ 370 see accessories.

I-Types

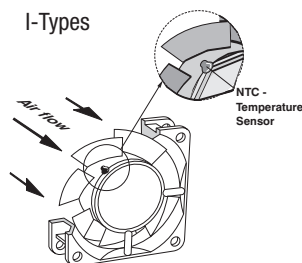

Temperature sensor (NTC-resistor) for controlling the motor speed is positioned directly in the air flow.

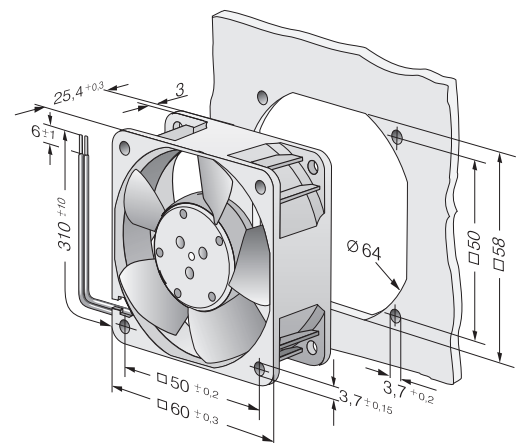

max. 82 m³/h

DC axial fans

Series 600 J 60 x 60 x 32 mm



Highlights:

- Very rigid compression curve for high air flow at high back pressure.
- Innovative impeller with winglets for low noise.

General characteristics:

- Material: fibreglass-reinforced plastic. Impeller PA, housing PBT.
- Fully integrated electronic commutation.
- Protected against reverse polarity and locking.
- Connection via single strands AWG 24, TR 64. Bared and tin-plated.
- Air exhaust over struts. Direction of rotation clockwise, seen on rotor.
- Mass: 100 g.

Nominal data		Air flow	Air flow	Nominal voltage	Voltage range	Sound pressure level	Sound power level	Sinter sleeve bearings Ball bearings	Power input	Nominal speed	Temperature range	Service life L ₁₀ (40 °C) ebm-papst Standard	Service life L ₁₀ (T _{max}) ebm-papst Standard	Life expectancy L ₁₀ Δ (40 °C) see P. 15	Curve	Specials
Type	m ³ /h	CFM	VDC	VDC	dB(A)	Bel(A)	□ / ■	Watts	RPM	°C	Hours	Hours	Hours	P. 110		
612 JH	70	41,1	12	7...13,6	53	6,4	■	7,7	11 700	-20...+70	57 500 / 27 500	115 000	1	/2		
614 JH	70	41,1	24	14...26,4	53	6,4	■	7,7	11 700	-20...+70	57 500 / 27 500	115 000	1	/2		
618 JH	70	41,1	48	36...60	53	6,4	■	7,7	11 700	-20...+70	57 500 / 27 500	115 000	1			
Fan types with streamer and integrated guard grille.																
NEW	614 J/2HHP	82	48,3	24	18...30	62	7,6	■	14,6	15 000	-20...+75	65 000 / 25 000	130 000	2		
NEW	618 J/2HHP	82	48,3	48	38...58	62	7,6	■	14,6	15 000	-20...+75	65 000 / 25 000	130 000	2		

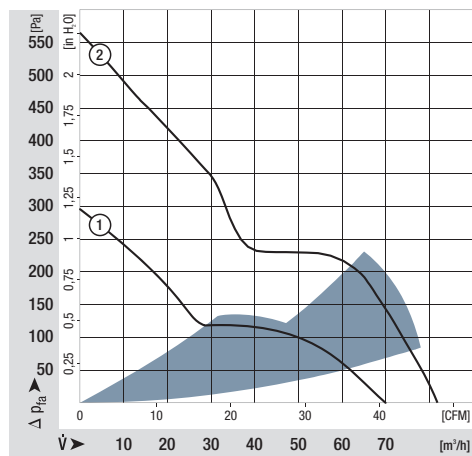
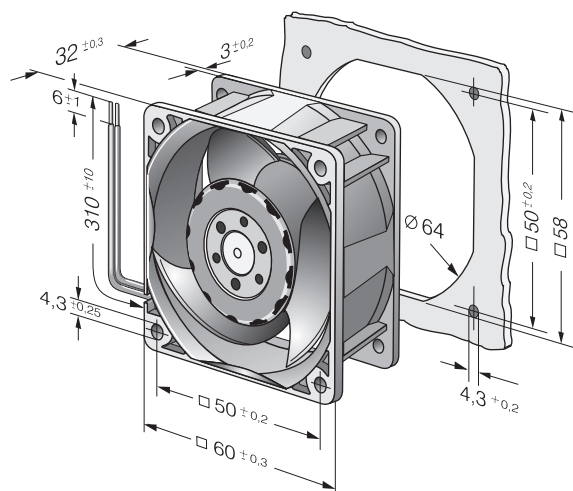
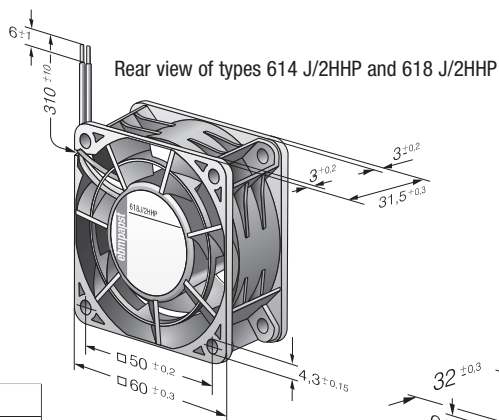

max. 44 m³/h

DC axial fans

Series 700 F 70 x 70 x 15 mm



Highlights:

- Very rigid compression curve for high air flow at high back pressure.
- Low operating noise level at high back pressure.

General characteristics:

- Material: fibreglass-reinforced plastic. Impeller PA, housing PBT.
- Fully integrated electronic commutation.
- Protected against reverse polarity and locking.
- Connection via single strands AWG 24 to AWG 28, TR 64. Bared and tin-plated.
- Air exhaust over struts. Direction of rotation counter-clockwise, seen on rotor.
- Mass: 53 g.

Nominal data	Air flow		Nominal voltage	Voltage range	Sound pressure level	Sound power level	Sinter sleeve bearings Ball bearings	Power input	Nominal speed	Temperature range	Service life L ₁₀ (40 °C) ebm-papst Standard	Service life L ₁₀ (T _{max}) ebm-papst Standard	Life expectancy L ₁₀ ^Δ (40 °C) see P. 15	Curve	Specials
	m ³ /h	CFM													
712 F/2L-005*	28	16,5	12	8...13,8	25	4,7	□	0,6	3 300	-20...+70	60 000 / 30 000	120 000	120 000	1	/2
712 F/2M-006*	36	21,2	12	8...13,8	32	5,0	□	1,1	4 300	-20...+70	60 000 / 30 000	120 000	120 000	2	/2
712 F	44	25,9	12	8...13,8	38	5,3	□	1,7	5 300	-20...+70	60 000 / 30 000	120 000	120 000	3	/2
714 F	44	25,9	24	18...28	38	5,3	□	1,5	5 300	-20...+70	60 000 / 30 000	120 000	120 000	3	

*Version with 3-pole Molex plug housing 22-01-2035
Molex Contacts 08-50-0113

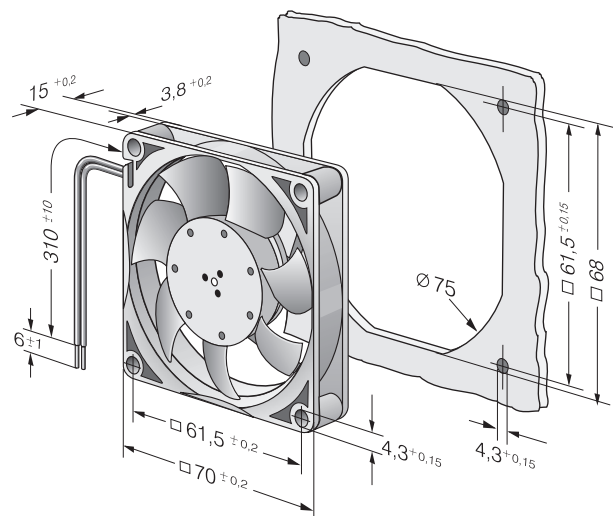
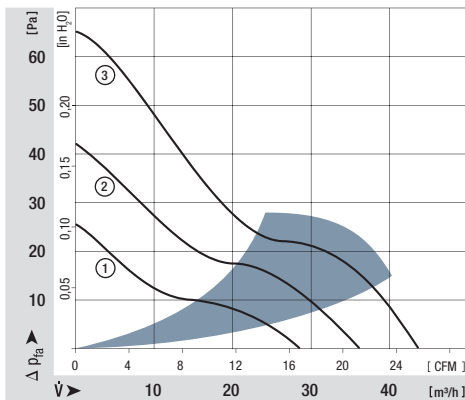

max. 117 m³/h

DC axial fans

Series 8450 80 x 80 x 25 mm



Highlights:

- Highly stable characteristic curve for high air flow at high back pressure.
- Motor with very low structure-borne noise properties.
- Innovative impeller with winglets for low noise.
- Extremely quiet Sintec sleeve bearing / ball bearing.
- Models with PWM control and open collector speed signal.

General characteristics:

- Material: fibreglass-reinforced plastic. Impeller PA, housing PBT.
- Fully integrated electronic commutation.
- Protected against reverse polarity and locking.
- Connection via single strands AWG 24, TR 64. Bared and tin-plated.
- Air exhaust over struts. Direction of rotation counter-clockwise, seen on rotor.
- Mass: 105 g.

Nominal data		Air flow	Air flow	Nominal voltage	Voltage range	Sound pressure level	Sound power level	Sintec sleeve bearings Ball bearings	Power input	Nominal speed	Temperature range	Service life L ₁₀ (40 °C) ebm-papst Standard	Service life L ₁₀ (T _{max}) ebm-papst Standard	Life expectancy L ₁₀ Δ (40 °C) see P. 15	Curve	Specials
Type		m ³ /h	CFM	VDC	VDC	dB(A)	Bel(A)	□ / ■	Watts	RPM	°C	Hours	Hours			
8452 GL		32	18,8	12	8...15	14	3,3	□	0,4	1 700	-20...75	80 000 / 35 000	160 000	1		
8452 GM		58	34,1	12	8...15	32	4,7	□	1,3	3 100	-20...75	80 000 / 35 000	160 000	2		
8452 GN		68	40,0	12	8...15	36	5,0	□	1,8	3 600	-20...70	70 000 / 35 000	140 000	3		
Models with 25 kHz PWM control and speed signal to 4-wire specification (see P. 121).																
8452 /2 GHP		75	44,1	12	10,8...13,2	38	5,3	□	2,5	4 000	-20...70	70 000 / 35 000	140 000	4		
8452 /2 GHHP		83	48,8	12	10,8...13,2	42	5,5	□	3,5	4 400	-20...60	65 000 / 40 000	130 000	5		
Models with 1-30 kHz PWM control and speed signal.																
NEW	8452 /2 H4P	117	68,8	12	8...15	50	6,4	■	6,8	6 200	-20...70	60 000 / 30 000	120 000	6		
NEW	8454 /2 H4P	117	68,8	24	20,0...26,4	50	6,4	■	6,8	6 200	-20...70	60 000 / 30 000	120 000	6		

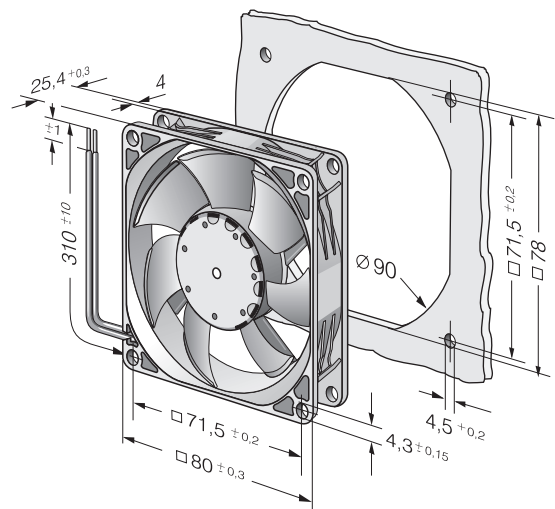
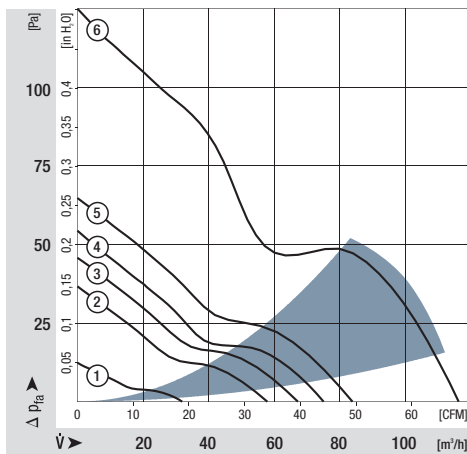

max. 79 m³/h

DC axial fans

Series 8400 N 80 x 80 x 25 mm

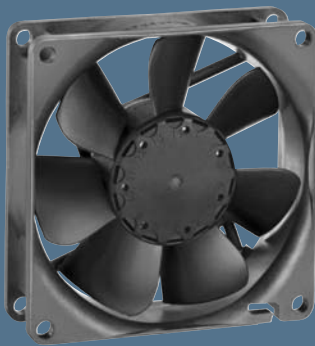

Highlights:

- Ball bearings and sleeve bearings available.
- Some models suitable for use at high ambient temperatures up to 85 °C.

General characteristics:

- Material: fibreglass-reinforced plastic. Impeller PA, housing PBT.
- Fully integrated electronic commutation.
- Protected against reverse polarity and locking.
- Connection via single strands AWG 24, TR 64. Bared and tin-plated.
- Air exhaust over struts. Direction of rotation counter-clockwise, seen on rotor.
- Mass: 95 g.

Nominal data	Air flow		Nominal voltage	Voltage range	Sound pressure level	Sound power level	Sinter sleeve bearings Ball bearings	Power input	Nominal speed	Temperature range	Service life L ₁₀ (40 °C) ebm-papst Standard	Service life L ₁₀ (T _{max}) ebm-papst Standard	Life expectancy L ₁₀ Δ (40 °C) see P. 15	Curve	Specials
	Type	m ³ /h													
8412 NGL	33	19,4	12	8...15	12	3,5	□	0,5	1 500	-20...+85	80 000 / 27 500	160 000	1	/2	
8412 NLE	33	19,4	12	8...15	17	3,7	■	0,3	1 500	-20...+85	80 000 / 27 500	160 000	1		
8412 NGMLE	45	26,5	12	8...15	19	3,9	□	0,9	2 050	-20...+80	80 000 / 32 500	160 000	2		
8412 NMLE	45	26,5	12	8...15	21	4,0	■	0,6	2 050	-20...+85	80 000 / 27 500	160 000	2		
8412 NGME	58	34,1	12	8...15	26	4,3	□	1,4	2 600	-20...+75	80 000 / 35 000	160 000	3	/2	
8412 NME	58	34,1	12	8...15	27	4,4	■	1,0	2 600	-20...+75	80 000 / 35 000	160 000	3		
8412 NG	69	40,6	12	8...15	32	4,7	□	2,0	3 100	-20...+70	70 000 / 35 000	140 000	4	/2	
8412 N	69	40,6	12	8...15	32	4,7	■	2,0	3 100	-20...+70	70 000 / 35 000	140 000	4	/2	
8412 NH	79	46,5	12	8...13,2	37	5,0	■	2,2	3 600	-20...+70	70 000 / 35 000	140 000	5	/2/12	
8412 NH-217	79	46,5	12	8...15	37	5,0	■	2,4	3 600	-20...+70	70 000 / 35 000	140 000	5		
8414 NGL	33	19,4	24	18...28	12	3,5	□	0,7	1 500	-20...+70	80 000 / 40 000	160 000	1	/2	
8414 NL	33	19,4	24	18...28	17	3,7	■	0,7	1 500	-20...+70	80 000 / 40 000	160 000	1		
8414 NGML	45	26,5	24	18...28	19	3,9	□	1,1	2 050	-20...+70	80 000 / 40 000	160 000	2		
8414 NML	45	26,5	24	18...28	21	4,0	■	1,1	2 050	-20...+70	80 000 / 40 000	160 000	2		
8414 NGM	58	34,1	24	18...28	26	4,3	□	1,4	2 600	-20...+70	80 000 / 40 000	160 000	3	/2	
8414 NM	58	34,1	24	18...28	27	4,4	■	1,4	2 600	-20...+70	80 000 / 40 000	160 000	3		
8414 NG	69	40,6	24	18...28	32	4,7	□	2,0	3 100	-20...+70	70 000 / 35 000	140 000	4	/2	
8414 N	69	40,6	24	18...28	32	4,7	■	2,0	3 100	-20...+70	70 000 / 35 000	140 000	4	/2	
8414 NH	79	46,5	24	18...26	37	5,0	■	2,4	3 600	-20...+70	70 000 / 35 000	140 000	5	/2	
8414 NH-221	79	46,5	24	18...28	37	5,0	■	2,4	3 600	-20...+70	70 000 / 35 000	140 000	5		
8418 N	69	40,6	48	36...56	32	4,7	■	2,0	3 100	-20...+70	70 000 / 35 000	140 000	4		

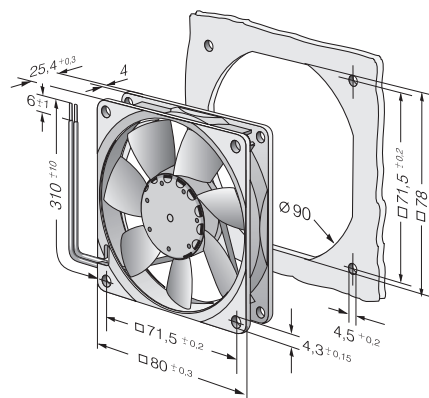
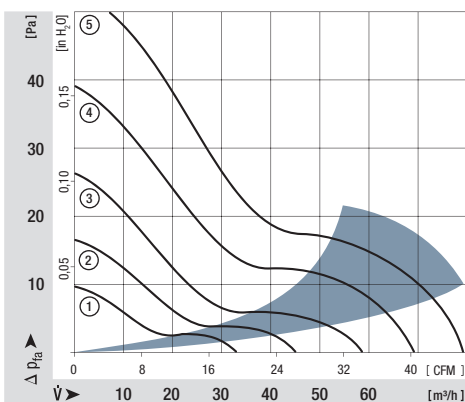

max. 58 m³/h

DC axial fans

Series 8400 N VARIOFAN 80 x 80 x 25 mm

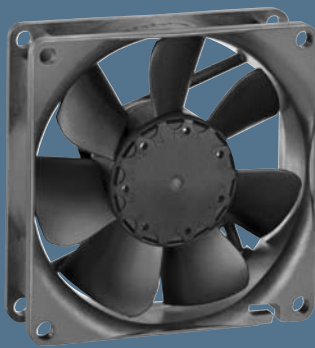

Highlights:

- Open loop speed control by means of (external or internal) temperature sensor.
- Automatic speed adjustment according to cooling requirements.

General characteristics:

- Material: fibreglass-reinforced plastic. Impeller PA, housing PBT.
- Fully integrated electronic commutation.
- Protected against reverse polarity and locking.
- Connection via single strands AWG 24, TR 64. Bared and tin-plated.
- Air exhaust over struts. Direction of rotation counter-clockwise, seen on rotor.
- Mass: 95 g.

Nominal data		Air flow		Nominal voltage	Voltage range	Sound pressure level	Sound power level	Sinter sleeve bearings Ball bearings	Power input	Nominal speed	Temperature range	Service life L ₁₀ (40 °C) ebm-papst Standard	Service life L ₁₀ (T _{max}) ebm-papst Standard	Life expectancy L ₁₀ Δ (40 °C) see P. 15	Curve	Specials
Type		m ³ /h	CFM	VDC	VDC	dB(A)	Bel(A)	□ / ■	Watts	RPM	°C	Hours	Hours		P. 117	
30°C 50°C	8412 NGLV	20 33	11,8 19,4	12	10...14	< 10 12	< 3 3,5	□	0,9 1,1	900 1 500	-20...+70	80 000 / 40 000	160 000	1 2		
30°C 50°C	8412 NGMLV	27 45	15,9 26,6	12	8...14	< 10 19	3,0 3,9	□	1,1 1,5	1 200 2 050	-20...+70	80 000 / 40 000	160 000	3 4	/37	
30°C 50°C	8412 NGMI	35 58	20,6 34,1	12	8...14	< 13 26	3,5 4,3	□	1,4 2,0	1 600 2 600	-20...+70	80 000 / 35 000	125 000	5 6		

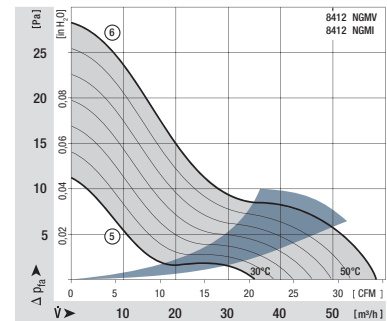
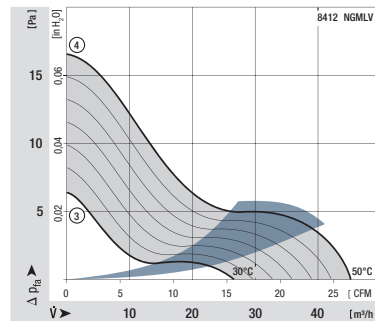
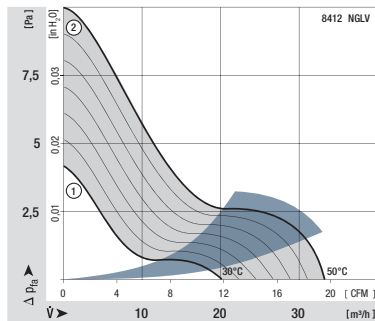

V-Types

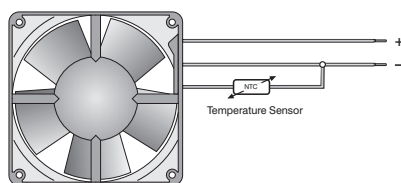

The temperature sensor for controlling the motor speed is not included in delivery.
Temperature sensor LZ 370 see accessories.

I-Types

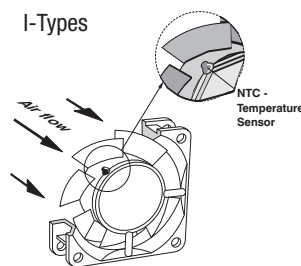

Temperature sensor (NTC-resistor) for controlling the motor speed is positioned directly in the air flow.

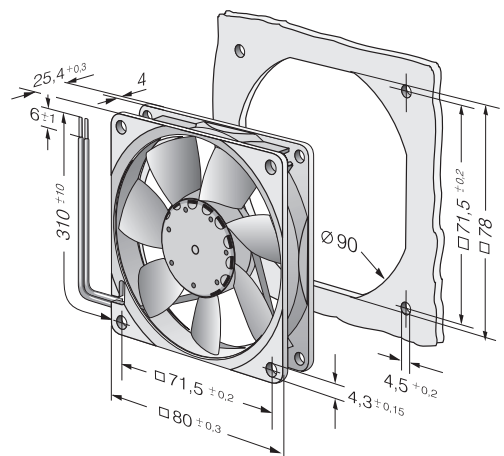

max. 80 m³/h

DC axial fans

Series 8300 80 x 80 x 32 mm



Highlights:

- Optional Vario-Pro: Highly adaptable software configuration of the fan enables a tailor-made solution to the specific requirements of your applications.

General characteristics:

- Material: fibreglass-reinforced plastic. Impeller PA, housing PBT.
- Fully integrated electronic commutation.
- Protected against reverse polarity and locking.
- Connection via single strands AWG 22, TR 64. Bared and tin-plated.
- Air exhaust over struts. Direction of rotation clockwise, seen on rotor.
- Mass: 170 g.

Nominal data	Air flow		Nominal voltage	Voltage range	Sound pressure level	Sound power level	Sinter sleeve bearings Ball bearings	Power input	Nominal speed	Temperature range	Service life L ₁₀ (40 °C) ebm-papst Standard	Service life L ₁₀ (T _{max}) ebm-papst Standard	Life expectancy L ₁₀ Δ (40 °C) see P. 15	Curve	Specials
	m ³ /h	CFM													
8312 L	32	18,8	12	6...15	24	4,0	■	1,2	2 000	-20...+75	80 000 / 32 500	160 000	1		
8312 M	48	28,3	12	6...15	34	5,0	■	2,2	3 000	-20...+75	70 000 / 27 500	140 000	2		
8312	54	31,8	12	6...15	36	5,2	■	2,6	3 300	-20...+75	70 000 / 27 500	140 000	3		
8312 HL	67	39,4	12	6...15	43	5,8	■	4,0	4 200	-20...+75	62 500 / 25 000	125 000	4	/2	
8312 H	80	47,1	12	6...12,6	48	6,2	■	6,5	5 000	-20...+60	55 000 / 35 000	110 000	5		
8314 L	32	18,8	24	12...31,5	24	4,0	■	1,0	2 000	-20...+75	80 000 / 32 500	160 000	1		
8314 M	48	28,3	24	12...31,5	34	5,0	■	2,3	3 000	-20...+75	70 000 / 27 500	140 000	2		
8314	54	31,8	24	12...31,5	36	5,2	■	2,7	3 300	-20...+75	70 000 / 27 500	140 000	3	/2	
8314 HL	67	39,4	24	12...31,5	43	5,8	■	4,3	4 200	-20...+75	62 500 / 25 000	125 000	4	/2	
8314 H	80	47,1	24	12...28	48	6,2	■	6,0	5 000	-20...+75	55 000 / 22 500	100 000	5	/2/19	
8318	54	31,8	48	36...56	36	5,2	■	2,6	3 300	-20...+75	70 000 / 27 500	140 000	3	/2/17	
8318 HL	67	39,4	48	36...56	43	5,8	■	4,3	4 200	-20...+75	62 500 / 25 000	125 000	4		
8318 H	80	47,1	48	36...56	48	6,2	■	5,8	5 000	-20...+65	55 000 / 30 000	100 000	5	/17	

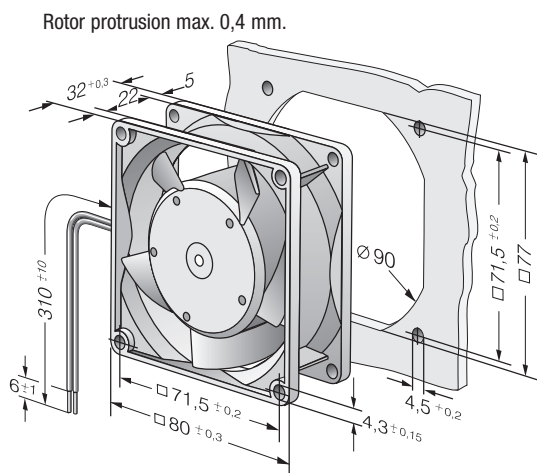
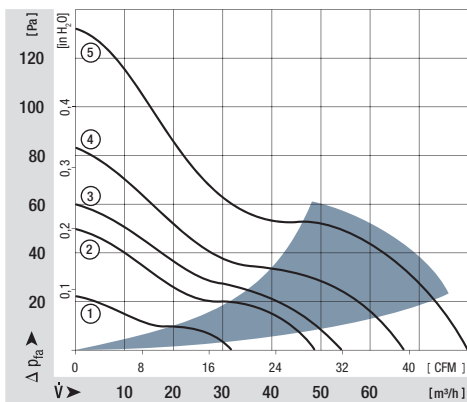

max. 222 m³/h

DC axial fans

Series 8200 J 80 x 80 x 38 mm



Highlights:

- Very rigid compression curve for high air flow at high back pressure.
- Innovative impeller with winglets for low noise.
- Optional Vario-Pro: Highly adaptable software configuration of the fan enables a tailor-made solution to the specific requirements of your applications.

General characteristics:

- Material: fibreglass-reinforced plastic. Impeller PA, housing PBT.
- Fully integrated electronic commutation. Protected against reverse polarity and locking.
- Connection via single strands AWG 24 (H3 and H4: AWG 22), TR 64. Bared and tin-plated.
- Air exhaust over struts. Direction of rotation counter-clockwise, seen on rotor.
- Mass: 160 g (H3 and H4: 200 g).

Nominal data		Air flow	Air flow	Nominal voltage	Voltage range	Sound pressure level	Sound power level	Sinter sleeve bearings Ball bearings	Power input	Nominal speed	Temperature range	Service life L ₁₀ (40 °C) ebm-papst Standard	Service life L ₁₀ (T _{max}) ebm-papst Standard	Life expectancy L ₁₀ Δ (40 °C) see P. 15	Curve	Specials
Type		m ³ /h	CFM	VDC	VDC	dB(A)	Bel(A)	□ / ■	Watts	RPM	°C	Hours	Hours		P. 110	
8212 JN		132	77,7	12	7...13,8	55	6,6	■	10	8400	-20...+70	62 500 / 32 500	130 000	1	/2	
8212 JH3	<i>S-Force</i>	190	111,8	12	6...13,8	66	7,3	■	25	12 000	-20...+70	55 000 / 27 500	110 000	2	/2	
8212 JH4	<i>S-Force</i>	222	130,7	12	6...13,8	71	7,8	■	39	14 000	-20...+70	50 000 / 25 000	100 000	3	/2	
8214 JN		132	77,7	24	18...26,4	55	6,6	■	10	8400	-20...+70	62 500 / 32 500	130 000	1	/2	
8214 JH3	<i>S-Force</i>	190	111,8	24	12...27,6	66	7,3	■	25	12 000	-20...+70	55 000 / 27 500	110 000	2	/2	
8214 JH4	<i>S-Force</i>	222	130,7	24	12...27,6	71	7,8	■	38	14 000	-20...+70	50 000 / 25 000	100 000	3	/2	
8218 JN		132	77,7	48	36...53	55	6,6	■	11	8400	-20...+70	62 500 / 32 500	130 000	1	/2	
8218 JH3	<i>S-Force</i>	190	111,8	48	20...58	66	7,3	■	25	12 000	-20...+70	55 000 / 27 500	110 000	2	/2	
8218 JH4	<i>S-Force</i>	222	130,7	48	20...58	71	7,8	■	36	14 000	-20...+70	50 000 / 25 000	100 000	3	/2	

8200 JH3 and JH4 also as standard with PWM control input and speed signal.
Speed control range from 2000 RPM up to maximum nominal speed. Stationary at 0 % PWM, maximum speed at sensor break.

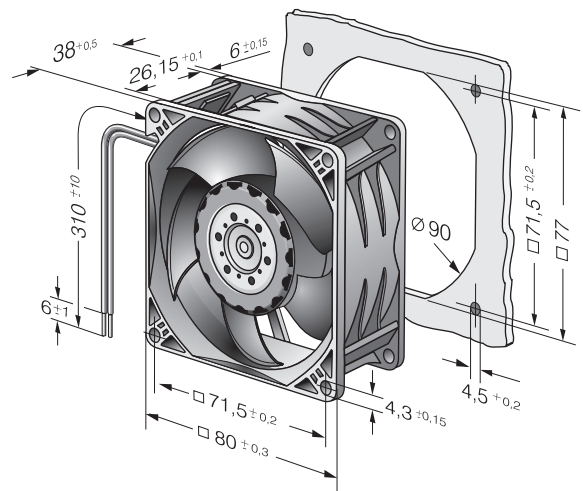
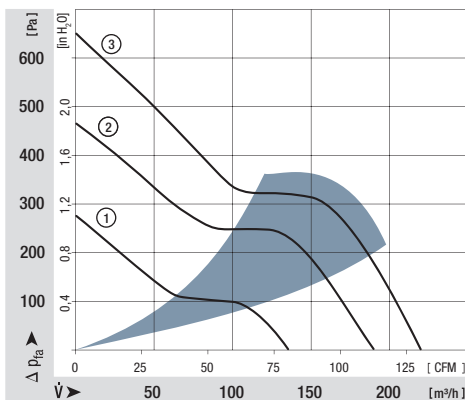

max. 102 m³/h

DC axial fans

Series 3400 N 92 x 92 x 25 mm



Highlights:

- Ball bearings and sleeve bearings available.
- Some models suitable for use at high ambient temperatures up to 85 °C.

General characteristics:

- Material: fibreglass-reinforced plastic. Impeller PA, housing PBT.
- Fully integrated electronic commutation.
- Protected against reverse polarity and locking.
- Connection via single strands AWG 24, TR 64. Bared and tin-plated.
- Air exhaust over struts. Direction of rotation counter-clockwise, seen on rotor.
- Mass: 100 g.

Nominal data	Air flow		Nominal voltage	Voltage range	Sound pressure level	Sound power level	Sinter sleeve bearings Ball bearings	Power input	Nominal speed	Temperature range	Service life L ₁₀ (40 °C) ebm-papst Standard	Service life L ₁₀ (T _{max}) ebm-papst Standard	Life expectancy L ₁₀ Δ (40 °C) see P. 15	Curve	Specials
	m ³ /h	CFM													
3412 NGLE	61	35,9	12	8...15	23	4,0	□	1,1	1 950	-20...+80	80 000 / 30 000	160 000	1		
3412 NLE	61	35,9	12	8...15	23	4,0	■	0,8	1 950	-20...+85	80 000 / 27 500	160 000	1		
3412 NGME	72	42,4	12	8...15	28	4,3	□	1,6	2 300	-20...+75	75 000 / 32 500	150 000	2		
3412 NME	72	42,4	12	8...15	28	4,3	■	1,1	2 300	-20...+75	75 000 / 32 500	150 000	2	/2	
3412 NG	84	49,4	12	8...15	32	4,7	□	2,2	2 700	-20...+70	70 000 / 35 000	140 000	3	/2	
3412 N	84	49,4	12	8...15	32	4,7	■	2,2	2 700	-20...+70	70 000 / 35 000	140 000	3	/2	
3412 NGH	94	55,3	12	8...15	36	5,0	□	2,5	3 000	-20...+70	70 000 / 35 000	140 000	4		
3412 NH	94	55,3	12	8...15	36	5,0	■	2,5	3 000	-20...+70	70 000 / 35 000	140 000	4	/39	
3412 NGHH	102	60,0	12	8...13,2	39	5,1	□	3,2	3 250	-20...+60	70 000 / 45 000	150 000	5	/2	
3412 NHH	102	60,0	12	8...13,2	39	5,1	■	2,9	3 250	-20...+60	70 000 / 45 000	150 000	5	/2	
3412 NHH-379	102	60,0	12	8...15	39	5,1	■	2,7	3 250	-20...+70	70 000 / 35 000	140 000	5		
3414 NGL	61	35,9	24	18...28	23	4,0	□	1,4	1 950	-20...+70	80 000 / 40 000	160 000	1		
3414 NL	61	35,9	24	18...28	23	4,0	■	1,4	1 950	-20...+70	80 000 / 40 000	160 000	1		
3414 NGM	72	42,4	24	18...28	28	4,3	□	1,8	2 300	-20...+70	75 000 / 37 500	150 000	2		
3414 NM	72	42,4	24	18...28	28	4,3	■	1,8	2 300	-20...+70	75 000 / 37 500	150 000	2		
3414 NG	84	49,4	24	18...28	32	4,7	□	2,3	2 700	-20...+70	70 000 / 35 000	140 000	3		
3414 N	84	49,4	24	18...28	32	4,7	■	2,3	2 700	-20...+70	70 000 / 35 000	140 000	3	/2	
3414 NGH	94	55,3	24	18...26	36	5,0	□	3,0	3 000	-20...+70	70 000 / 35 000	140 000	4	/2	
3414 NH	94	55,3	24	18...26	36	5,0	■	3,0	3 000	-20...+70	70 000 / 35 000	140 000	4		
3414 NGHH	102	60,0	24	18...26	39	5,1	□	3,2	3 250	-20...+70	70 000 / 35 000	140 000	5	/2	
3414 NGH-389	102	60,0	24	18...28	39	5,1	□	3,2	3 250	-20...+70	70 000 / 35 000	140 000	5		
3414 NHH	102	60,0	24	18...26	39	5,1	■	2,7	3 250	-20...+70	70 000 / 35 000	140 000	5	/39	
3414 NHH-386	102	60,0	24	18...28	39	5,1	■	2,7	3 250	-20...+70	70 000 / 35 000	140 000	5		
3418 N	84	49,4	48	36...56	32	4,7	■	2,4	2 700	-20...+70	70 000 / 35 000	140 000	3		

Other 48 VDC models on request.

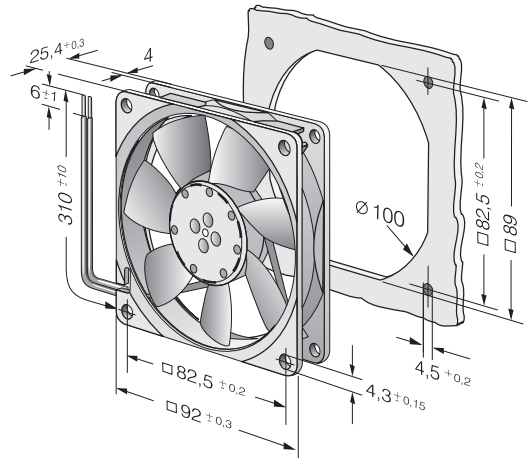
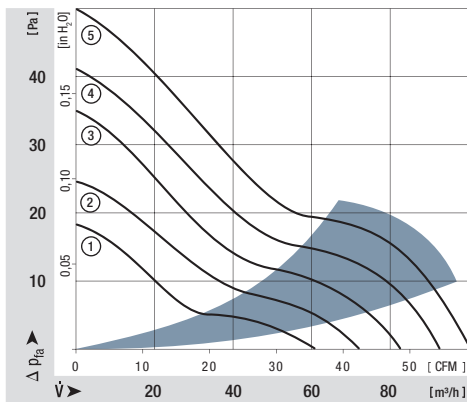

max. 84 m³/h

DC axial fans

Series 3400 N VARIOFAN 92 x 92 x 25 mm



Highlights:

- Open loop speed control by means of external or internal temperature sensor.
- Automatic speed adjustment according to cooling requirements.

General characteristics:

- Material: fibreglass-reinforced plastic. Impeller PA, housing PBT.
- Fully integrated electronic commutation.
- Protected against reverse polarity and locking.
- Connection via single strands AWG 24, TR 64. Bared and tin-plated.
- Air exhaust over struts. Direction of rotation counter-clockwise, seen on rotor.
- Mass: 100 g.

Nominal data		Air flow	Air flow	Nominal voltage	Voltage range	Sound pressure level	Sound power level	Sintec sleeve bearings Ball bearings	Power input	Nominal speed	Temperature range	Service life L ₁₀ (40 °C) ebm-papst Standard	Service life L ₁₀ (T _{max}) ebm-papst Standard	Life expectancy L ₁₀ Δ (40 °C), see P. 15	Curve	Specials
Type		m ³ /h	CFM	VDC	VDC	dB(A)	Bel(A)	□ / ■	Watts	RPM	°C	Hours	Hours		P. 117	
30°C 50°C	3412 NGMV	44	25,9	12	8...14	14	3,5	□	1,5	1 400	-20...+70	75 000 / 37 500	142 500		1	
		72	42,4			28	4,3		2,0	2 300					2	
30°C 50°C	3412 NGV	50	29,4	12	8...12,6	16	3,7	□	1,6	1 600	-20...+70	75 000 / 37 500	142 500		3	/37
		84	49,4			32	4,7		2,5	2 700					4	

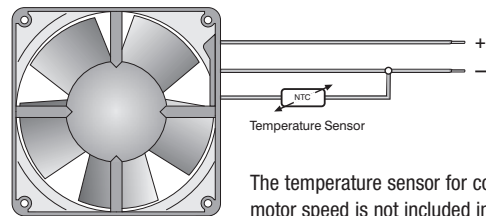
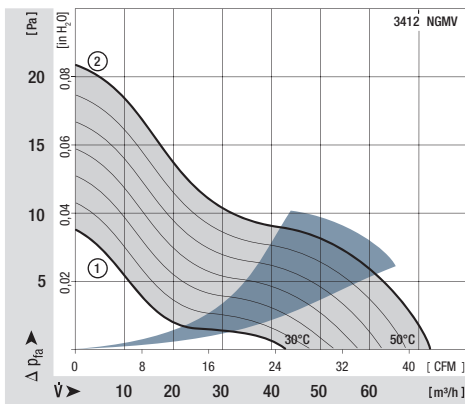

The temperature sensor for controlling the motor speed is not included in delivery. Temperature sensor LZ 370 see accessories.

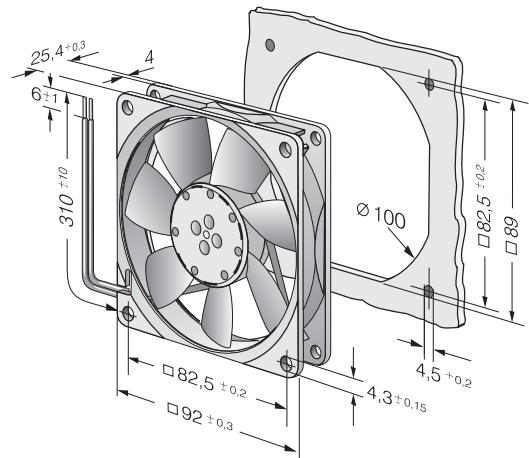
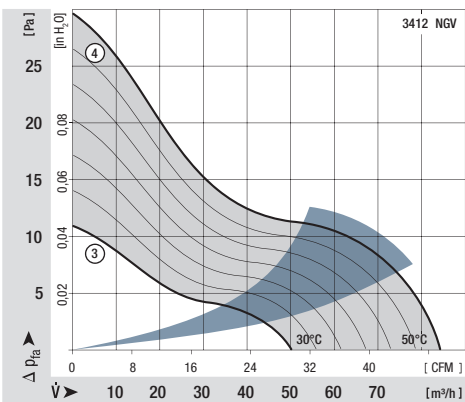

max. 107 m³/h

DC axial fans

Series 3300 92 x 92 x 32 mm



Highlights:

- Ball bearings and sleeve bearings available.
- Optional Vario-Pro: Highly adaptable software configuration of the fan enables a tailor-made solution to the specific requirements of your applications.

General characteristics:

- Material: fibreglass-reinforced plastic. Impeller PA, housing PBT.
- Fully integrated electronic commutation.
- Protected against reverse polarity and locking.
- Connection via single strands AWG 22, TR 64. Bared and tin-plated.
- Air exhaust over struts. Direction of rotation clockwise, seen on rotor.
- Mass: 190 g.

Nominal data		Air flow	Air flow	Nominal voltage	Voltage range	Sound pressure level	Sound power level	Sinter sleeve bearings Ball bearings	Power input	Nominal speed	Temperature range	Service life L ₁₀ (40 °C) ebm-papst Standard	Service life L ₁₀ (T _{max}) ebm-papst Standard	Life expectancy L ₁₀ Δ (40 °C) see p. 15	Curve	Specials
Type	m ³ /h	CFM	VDC	VDC	dB(A)	Bel(A)	■ / ■	Watts	RPM	°C	Hours	Hours	P. 110-114			
3312 L	56	33,0	12	6...15	29	4,5	■	1,4	2 150	-20...+75	80 000 / 35 000	147 500	1			
3312 GM	68	40,0	12	6...15	34	4,8	■	1,7	2 600	-20...+75	70 000 / 30 000	135 000	2			
3312 M	68	40,0	12	6...15	34	4,8	■	1,7	2 600	-20...+75	70 000 / 30 000	135 000	2			
3312	80	47,1	12	6...15	37	5,2	■	2,4	3 000	-20...+75	70 000 / 30 000	135 000	3	/2		
3312-177	93	54,7	12	6...15	43	5,7	■	3,5	3 500	-20...+75	65 000 / 27 500	122 500	5			
3314 G	80	47,1	24	12...28	37	5,2	■	2,6	3 000	-20...+75	70 000 / 30 000	135 000	3			
3314	80	47,1	24	12...28	37	5,2	■	2,6	3 000	-20...+75	70 000 / 30 000	135 000	3	/17		
3314-140	85	50,0	24	12...28	40	5,4	■	3,0	3 200	-20...+75	70 000 / 30 000	135 000	4			
3314 H	107	63,0	24	12...28	47	6,0	■	5,3	4 000	-20...+75	57 500 / 25 000	112 500	6	/2		
3318	80	47,1	48	36...56	37	5,2	■	2,7	3 000	-20...+75	70 000 / 30 000	135 000	3	/2		
3318 H	107	63,0	48	36...56	47	6,0	■	4,3	4 000	-20...+60	57 500 / 35 000	112 500	6	/2/17		

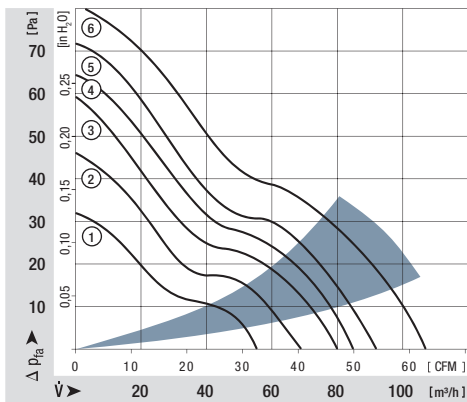

Rotor protrusion max. 0,4 mm.

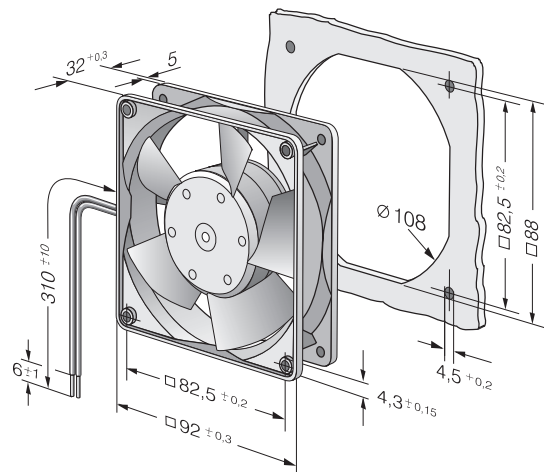

max. 280 m³/h

DC axial fans

Series 3200 J 92 x 92 x 38 mm



Highlights:

- Very rigid compression curve for high air flow at high back pressure.
- Innovative impeller with winglets for low noise.
- Optional Vario-Pro: Highly adaptable software configuration of the fan enables a tailor-made solution to the specific requirements of your applications.

General characteristics:

- Material: fibreglass-reinforced plastic. Impeller PA, housing PBT.
- Fully integrated electronic commutation. Protected against reverse polarity and locking.
- Connection via single strands AWG 24 (H3 and H4: AWG 22), TR 64. Bared and tin-plated.
- Air exhaust over struts. Direction of rotation clockwise, seen on rotor.
- Mass: 240 g (H3 and H4: 280 g).

Nominal data		Air flow	Air flow	Nominal voltage	Voltage range	Sound pressure level	Sound power level	Sinter sleeve bearings Ball bearings	Power input	Nominal speed	Temperature range	Service life L ₁₀ (40 °C) ebm-papst Standard	Service life L ₁₀ (T _{max}) ebm-papst Standard	Life expectancy L ₁₀ Δ (40 °C) see P. 15	Curve	Specials
Type		m ³ /h	CFM	VDC	VDC	dB(A)	Bel(A)	■ / ■	Watts	RPM	°C	Hours	Hours		P. 110	
3212 JN		130	76,5	12	7...13,8	51	6,1	■	7,5	6 000	-20 ...+70	70 000 / 35 000	140 000	1	/2	
3212 JH		146	86,0	12	7...15	55	6,4	■	9,0	6 800	-20 ...+70	70 000 / 35 000	140 000	2	/2	
3212 JH3 <i>S-Force</i>		237	139,5	12	6...13,8	69	7,8	■	30,0	11 000	-20 ...+70	65 000 / 32 500	130 000	3	/2	
3212 JH4 <i>S-Force</i>		280	164,8	12	6...13,8	73	8,2	■	50,0	13 000	-20 ...+70	60 000 / 30 000	120 000	4	/2	
3214 JN		130	76,5	24	11...28	51	6,1	■	8,0	6 000	-20 ...+70	70 000 / 35 000	140 000	1		
3214 JH		146	86,0	24	11...30	55	6,4	■	9,0	6 800	-20 ...+70	70 000 / 35 000	140 000	2	/2	
3214 JH3 <i>S-Force</i>		237	139,5	24	12...27,6	69	7,8	■	30,0	11 000	-20 ...+70	65 000 / 32 500	130 000	3	/2	
3214 JH4 <i>S-Force</i>		280	164,8	24	12...27,6	73	8,2	■	50,0	13 000	-20 ...+70	60 000 / 30 000	120 000	4		
3218 JN		130	76,5	48	36...56	51	6,1	■	7,0	6 000	-20 ...+70	70 000 / 35 000	140 000	1		
3218 JH		146	86,0	48	36...53	55	6,4	■	9,5	6 800	-20 ...+70	70 000 / 35 000	140 000	2		
3218 JH3 <i>S-Force</i>		237	139,5	48	20...58,0	69	7,8	■	30,0	11 000	-20 ...+70	65 000 / 32 500	130 000	3	/2	
3218 JH4 <i>S-Force</i>		280	164,8	48	20...58,0	73	8,2	■	50,0	13 000	-20 ...+70	60 000 / 30 000	120 000	4		

3200 JH3 and JH4 also as standard with PWM control input and speed signal.
Speed control range from 2000 RPM up to maximum nominal speed. Stationary at 0 % PWM, maximum speed at sensor break.

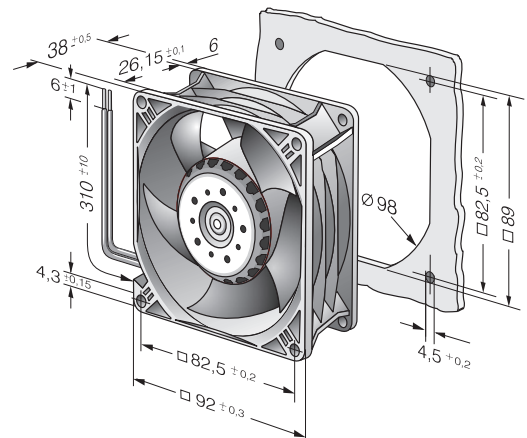
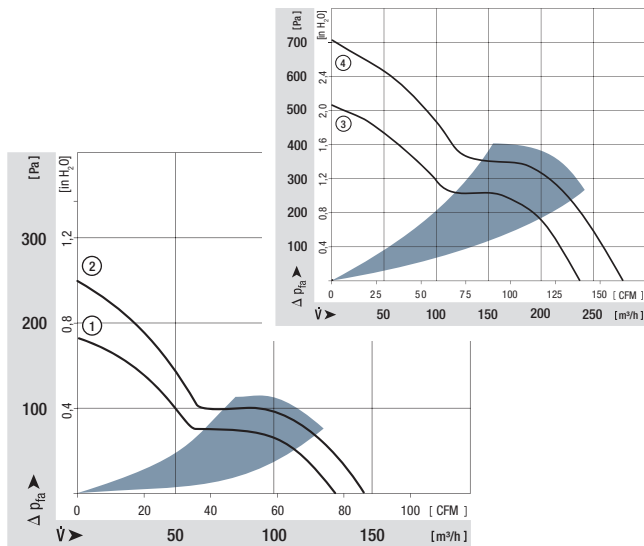

max. 170 m³/h

DC axial fans

Series 4400 F 119 x 119 x 25 mm



Highlights:

- Ball bearings and sleeve bearings available.
- Open loop speed control available on request.
- Alarm and speed signals available on request.

General characteristics:

- Material: fibreglass-reinforced plastic. Impeller PA, housing PBT.
- Fully integrated electronic commutation.
- Protected against reverse polarity and locking.
- Connection via single strands AWG 24, TR 64. Bared and tin-plated.
- Air exhaust over struts. Direction of rotation counter-clockwise, seen on rotor.
- Mass: 175 g.

Nominal data	Air flow		Nominal voltage	Voltage range	Sound pressure level	Sound power level	Sinter sleeve bearings Ball bearings	Power input	Nominal speed	Temperature range	Service life L ₁₀ (40 °C) ebm-papst Standard	Service life L ₁₀ (T _{max}) ebm-papst Standard	Life expectancy L ₁₀ Δ (40 °C) see P. 15	Curve	Specials
	m ³ /h	CFM													
4412 FGL	94	55,3	12	7...14	26	3,9	□	1,3	1 600	-20...+75	80 000 / 35 000	157 500	1	/2/39	
4412 FGML	114	67,1	12	7...12,6	32	4,3	□	2,0	1 950	-20...+75	75 000 / 32 500	145 000	2	/2	
4412 FML	114	67,1	12	7...12,6	32	4,3	■	2,0	1 950	-20...+75	75 000 / 32 500	145 000	2		
4412 FGM	140	82,4	12	7...12,6	38	4,8	□	3,2	2 400	-20...+75	70 000 / 30 000	135 000	3	/12/39	
4412 FM	140	82,4	12	7...12,6	38	4,8	■	3,2	2 400	-20...+75	70 000 / 30 000	135 000	3	/2	
4412 FG	170	100,1	12	8...12,6	43	5,3	□	5,3	2 900	-20...+60	60 000 / 37 500	120 000	4		
4412 F	170	100,1	12	8...12,6	43	5,3	■	5,3	2 900	-20...+60	60 000 / 37 500	120 000	4	/2	
4414 FL	94	55,3	24	18...28	26	3,9	■	1,0	1 600	-20...+75	80 000 / 35 000	157 500	1	/2	
4414 FM	140	82,4	24	12...28	38	4,8	■	3,2	2 400	-20...+75	70 000 / 30 000	135 000	3	/2	
4414 FG	170	100,1	24	12...28	43	5,3	□	5,0	2 900	-20...+60	60 000 / 37 500	120 000	4	/2	
4414 F	170	100,1	24	12...28	43	5,3	■	5,0	2 900	-20...+60	60 000 / 37 500	120 000	4	/2/39	
4418 FG	170	100,1	48	28...53	43	5,3	□	5,5	2 900	-20...+60	60 000 / 37 500	120 000	4		
4418 F	170	100,1	48	28...53	43	5,3	■	5,5	2 900	-20...+60	60 000 / 37 500	120 000	4	/2/12	

Available on request:
Fan housing with moulded-in
spacers. For mounting over
both flanges.

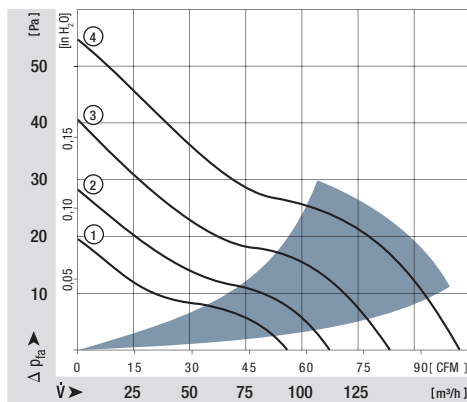
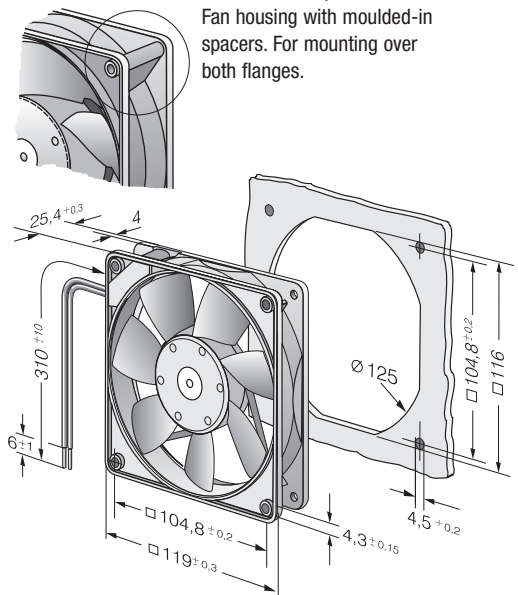

max. 225 m³/h

DC axial fans

Series 4400 FN 119 x 119 x 25 mm



Highlights:

- Very rigid compression curve for high air flow at high back pressure.
- Innovative impeller with winglets for low noise.
- Optional Vario-Pro: Highly adaptable software configuration of the fan enables a tailor-made solution to the specific requirements of your applications.

General characteristics:

- Material: fibreglass-reinforced plastic. Impeller PA, housing PBT.
- Fully integrated electronic commutation.
- Protected against reverse polarity and locking.
- Connection via single strands AWG 22, TR 64. Bared and tin-plated.
- Air exhaust over struts. Direction of rotation counter-clockwise, seen on rotor.
- Mass: 240 g.

Nominal data		Air flow	Air flow	Nominal voltage	Voltage range	Sound pressure level	Sound power level	Sinter sleeve bearings Ball bearings	Power input	Nominal speed	Temperature range	Service life L ₁₀ (40 °C) ebm-papst Standard	Service life L ₁₀ (T _{max}) ebm-papst Standard	Life expectancy L ₁₀ Δ (40 °C) see P. 15	Curve	Specials
Type		m ³ /h	CFM	VDC	VDC	dB(A)	Bel(A)	■ / ■	Watts	RPM	°C	Hours	Hours		P. 110/118	
4412 FNH		225	132,4	12	7...13,2	55	6,7	■	12	5 400	-20...+70	60 000 / 30 000	120 000	2	/2	
4414 FNN		200	117,7	24	14...28	52	6,5	■	8,5	4 850	-20...+70	60 000 / 30 000	120 000	1	/2	
4414 FNH		225	132,4	24	18...26,4	55	6,7	■	12	5 400	-20...+70	60 000 / 30 000	120 000	2	/39	
4418 FNH		225	132,4	48	36...53	55	6,7	■	12	5 400	-20...+70	60 000 / 30 000	120 000	2		

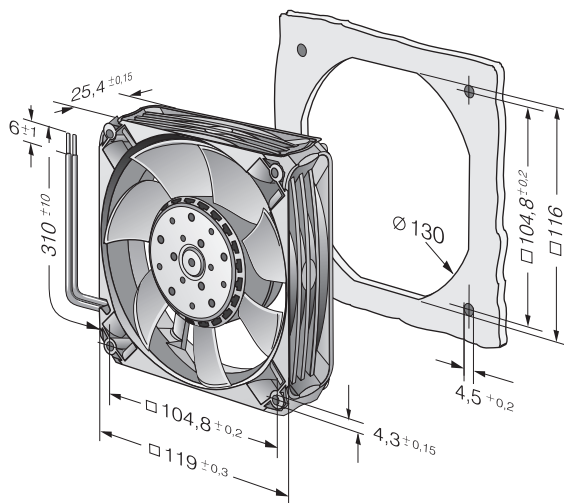
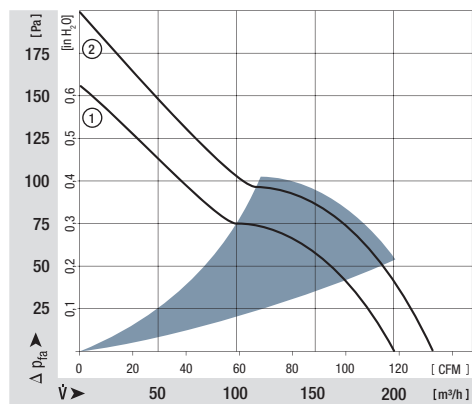

max. 204 m³/h

DC axial fans

Series 4300 119 x 119 x 32 mm



Highlights:

- Ball bearings and sleeve bearings available.
- Optional Vario-Pro: Highly adaptable software configuration of the fan enables a tailor-made solution to the specific requirements of your applications

General characteristics:

- Material: fibreglass-reinforced plastic. Impeller PA, housing PBT.
- Fully integrated electronic commutation.
- Protected against reverse polarity and locking.
- Connection via single strands AWG 22, TR 64. Bared and tin-plated.
- Air exhaust over struts. Direction of rotation clockwise, seen on rotor.
- Mass: 220 g.

Nominal data		Air flow	Air flow	Nominal voltage	Voltage range	Sound pressure level	Sound power level	Sinter sleeve bearings Ball bearings	Power input	Nominal speed	Temperature range	Service life L ₁₀ (40 °C) ebm-papst Standard	Service life L ₁₀ (T _{max}) ebm-papst Standard	Life expectancy L ₁₀ ^Δ (40 °C) see P. 15	Curve	Specials
Type	m ³ /h	CFM	VDC	VDC	dB(A)	Bel(A)	□ / ■	Watts	RPM	°C	Hours	Hours	P. 110-116			
4312 GL	95	55,9	12	6...15	30	4,3	□	1,2	1 550	-20...+75	80 000 / 35 000	157 500	1			
4312 L	95	55,9	12	6...15	30	4,3	■	1,2	1 550	-20...+75	80 000 / 35 000	157 500	1			
4312 GM	140	82,4	12	6...15	39	5,3	□	2,6	2 300	-20...+75	70 000 / 30 000	135 000	2			
4312 M	140	82,4	12	6...15	39	5,3	■	2,6	2 300	-20...+75	70 000 / 30 000	135 000	2	/12		
4312 G	170	100,1	12	6...15	45	5,8	□	5,0	2 800	-20...+75	62 500 / 27 500	122 500	3			
4312	170	100,1	12	6...15	45	5,8	■	5,0	2 800	-20...+75	62 500 / 27 500	122 500	3	/2/19		
4312-179	204	120,1	12	6...13,2	51	6,4	■	8,5	3 400	-20...+75	47 500 / 20 000	90 000	5			
4314 L	95	55,9	24	12...28	30	4,3	■	1,2	1 550	-20...+75	80 000 / 35 000	157 500	1			
4314 M	140	82,4	24	12...28	39	5,3	■	2,6	2 300	-20...+75	70 000 / 30 000	135 000	2			
4314 G	170	100,1	24	12...28	45	5,8	□	5,0	2 800	-20...+75	62 500 / 27 500	122 500	3			
4314	170	100,1	24	12...28	45	5,8	■	5,0	2 800	-20...+75	62 500 / 27 500	112 500	3	/2/12		
4314-147	180	105,9	24	12...28	47	6,1	■	5,8	3 000	-20...+75	57 500 / 25 000	112 500	4			
4314-180	204	120,1	24	12...26,5	51	6,4	■	9,5	3 400	-20...+75	45 000 / 20 000	90 000	5			
4318 M	140	82,4	48	36...56	39	5,3	■	3,5	2 300	-20...+75	70 000 / 30 000	135 000	2			
4318	170	100,1	48	36...53	45	5,8	■	5,0	2 800	-20...+75	62 500 / 27 500	112 500	3	/2/17		

Rotor protrusion max. 0,4 mm.

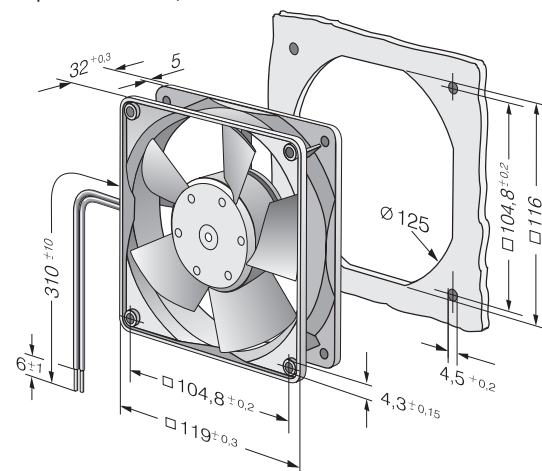
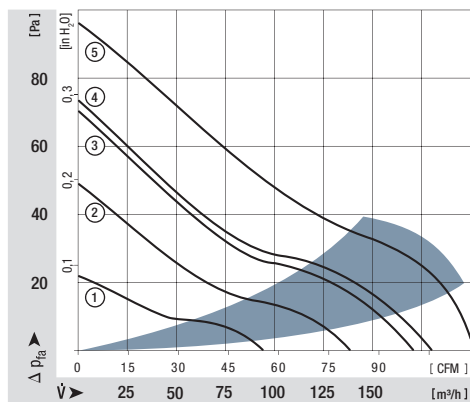

max. 170 m³/h

DC axial fans

Series 4300 119 x 119 x 32 mm

Highlights:

- Open loop speed control by means of external or internal temperature sensor.
- Automatic speed adjustment according to cooling requirements.

General characteristics:

- Material: fibreglass-reinforced plastic. Impeller PA, housing PBT.
- Fully integrated electronic commutation.
- Protected against reverse polarity and locking.
- Connection via single strands AWG 22, TR 64. Bared and tin-plated.
- Air exhaust over struts. Direction of rotation clockwise, seen on rotor.
- Mass: 220 g.

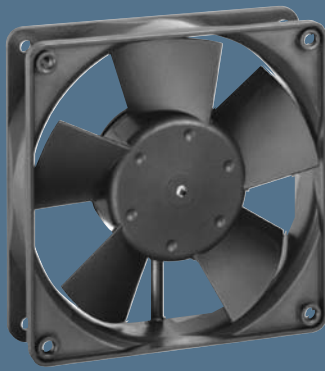

Nominal data		Air flow	Air flow	Nominal voltage	Voltage range	Sound pressure level	Sound power level	Sinter sleeve bearings Ball bearings	Power input	Nominal speed	Temperature range	Service life L ₁₀ (40 °C) ebm-papst Standard	Service life L ₁₀ (T _{max}) ebm-papst Standard	Life expectancy L ₁₀ Δ (40 °C) see P. 15	Curve	Specials
Type		m ³ /h	CFM	VDC	VDC	dB(A)	Bel(A)	□ / ■	Watts	RPM	°C	Hours	Hours	Hours	P. 114	
25°C 50°C	4312 MT	65 138	38,2 81,2	12	8...15	25 39	3,9 5,3	■	1,1 3,0	1 100 2 300	-20...+65	70 000 / 40 000	142 500	1 2	/17	
25°C 50°C	4312 T	85 170	50,0 100,1	12	8...13,2	29 45	4,2 5,8	■	2,4 5,5	1 400 2 800	-20...+65	65 000 / 35 000	132 500	3 4	/17	
30°C 50°C	4314 T	85 170	50,0 100,1	24	18...32	29 45	4,2 5,8	■	1,6 4,8	1 400 2 800	-20...+65	65 000 / 35 000	132 500	3 4	/17	
25°C 50°C	4318 V	61 170	35,9 100,0	48	40...53	21 45	— 5,8	■	2,6 5,4	1 000 2 800	-20...+65	65 000 / 35 000	132 500	5 6	/17	

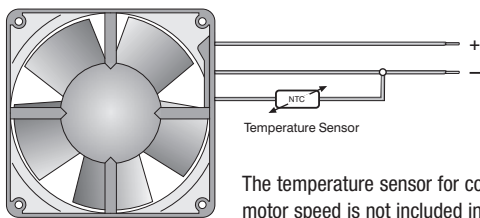
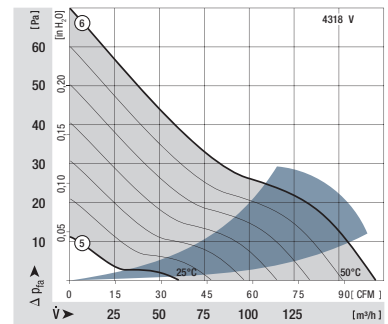
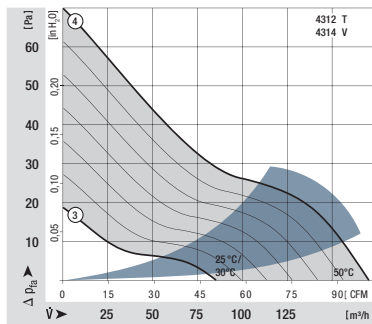
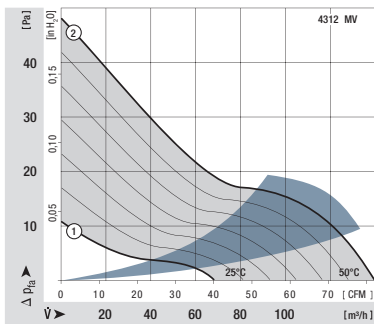

The temperature sensor for controlling the motor speed is not included in delivery. Temperature sensor LZ 370 see accessories.

Rotor protrusion max. 0.4 mm.

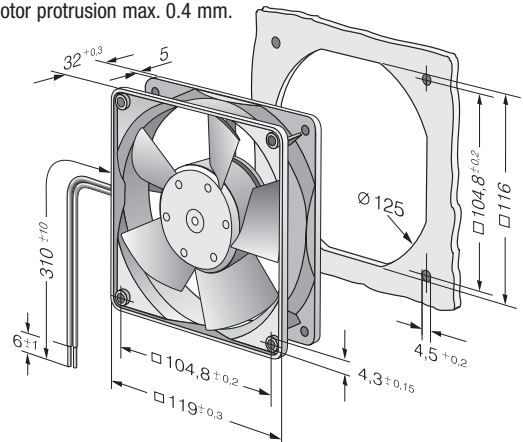

max. 285 m³/h

DC axial fans

Series 4400 119 x 119 x 38 mm



Highlights:

- Innovative impeller with winglets for low noise.
- Control inputs, alarm and speed signals available on request.
- High-speed version with 5000 rpm, standard models available with /2 and PWM.

General characteristics:

- Material: fibreglass-reinforced plastic. Impeller PA, housing PBT.
- Fully integrated electronic commutation.
- Protected against reverse polarity and locking.
- Connection via single strands AWG 24, TR 64. Bared and tin-plated.
- Air exhaust over struts. Direction of rotation clockwise, seen on rotor.
- Mass: 270 g.

Nominal data	Air flow		Nominal voltage	Voltage range	Sound pressure level	Sound power level	Sinter sleeve bearings Ball bearings	Power input	Nominal speed	Temperature range	Service life L ₁₀ (40 °C) ebm-papst standard	Service life L ₁₀ (T _{max}) ebm-papst standard	Life expectancy L ₁₀ Δ (40 °C) see P. 15	Curve	Specials
	m ³ /h	CFM													
4412 L	150	88,3	12	7...14	37	5,0	■	2,5	2 700	-20...+70	67 500 / 35 000	140 000	1		
4412 M	184	108,3	12	7...14	42	5,3	■	4,2	3 300	-20...+70	65 000 / 32 500	130 000	2		
4412 N	205	120,7	12	7...14	46	5,6	■	5,5	3 650	-20...+70	62 500 / 30 000	120 000	3	/2	
4412 H	240	141,3	12	7...14	50	6,0	■	8,9	4 300	-20...+70	57 500 / 27 500	110 000	4	/2	
4412 /2 HHP	285	167,7	12	7...14,5	55	6,4	■	13,0	5 000	-20...+70	50 000 / 25 000	100 000	5	/2	
4414 L	150	88,3	24	18...28	37	5,0	■	2,5	2 700	-20...+70	67 500 / 35 000	140 000	1		
4414 M	184	108,3	24	18...28	42	5,3	■	4,0	3 300	-20...+70	65 000 / 32 500	130 000	2		
4414 N	205	120,7	24	18...28	46	5,6	■	5,2	3 650	-20...+70	62 500 / 30 000	120 000	3		
4414 H	240	141,3	24	18...28	50	6,0	■	8,6	4 300	-20...+70	57 500 / 27 500	110 000	4	/2	
4414 HH	285	164,8	24	16...28	55	6,4	■	14,0	5 000	-20...+70	50 000 / 25 000	100 000	5		
4414 /2 HHP	285	167,7	24	18...28	55	6,4	■	12,0	5 000	-20...+70	50 000 / 25 000	100 000	5	/2	
4418 L	150	88,3	48	36...60	37	5,0	■	2,5	2 700	-20...+70	67 500 / 35 000	140 000	1		
4418 M	184	108,3	48	36...60	42	5,3	■	4,2	3 300	-20...+70	65 000 / 32 500	130 000	2		
4418 N	205	120,7	48	36...60	46	5,6	■	5,2	3 650	-20...+70	62 500 / 30 000	120 000	3		
4418 H	240	141,3	48	36...60	50	6,0	■	8,6	4 300	-20...+70	57 500 / 27 500	110 000	4	/2	
4418 /2 HHP	285	167,7	48	36...60	55	6,4	■	13,5	5 000	-20...+70	50 000 / 25 000	100 000	5	/2	

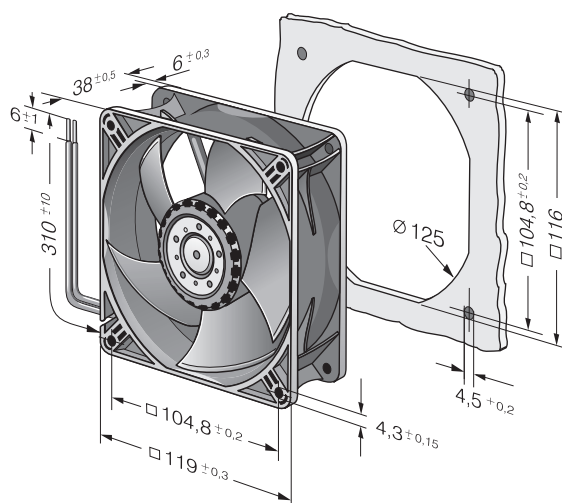
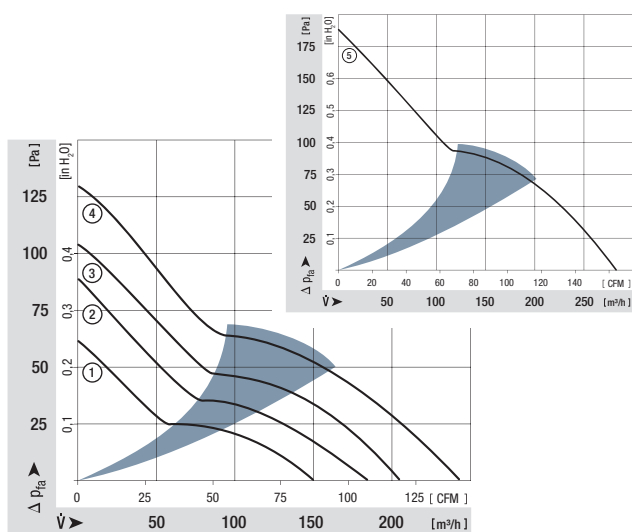

max. 237 m³/h

DC axial fans

Series 4100 N 119 x 119 x 38 mm

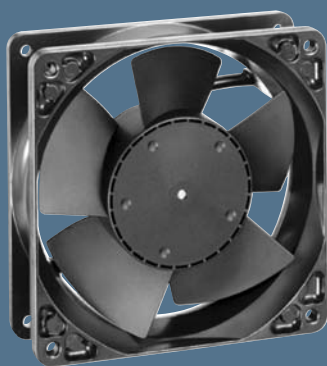

Highlights:

- Very rigid compression curve for high air flow at high back pressure.
- Low operating noise level at high back pressure.
- Optional Vario-Pro: Highly adaptable software configuration of the fan enables a tailor-made solution to the specific requirements of your applications.

General characteristics:

- Material: aluminium housing, fibreglass-reinforced PA impeller; housing with grounding lug for screw M4 x 8 (Torx).
- Fully integrated electronic commutation.
- Protected against reverse polarity and locking.
- Electrical connection with flat plugs, 2.8 x 0.5 mm. Optionally with strands.
- Air intake over struts. Direction of rotation clockwise, seen on rotor.
- Mass: 390 g.

Nominal data		Air flow	Air flow	Nominal voltage	Voltage range	Sound pressure level	Sound power level	Sinter sleeve bearings Ball bearings	Power input	Nominal speed	Temperature range	Service life L ₁₀ (40 °C) ebm-papst Standard	Service life L ₁₀ (T _{max}) ebm-papst Standard	Life expectancy L ₁₀ Δ (40 °C), see P. 15	Curve	Specials
Type	m ³ /h	CFM	VDC	VDC	dB(A)	Bel(A)	□ / ■	Watts	RPM	°C	Hours	Hours	Hours	P. 110-114		
4182 NGX	160	94,2	12	7...15	44	5,3	□	3,5	2 800	-10...+75	85 000 / 37 500	167 500	1	/2		
4182 NX	180	105,9	12	7...15	49	5,7	■	4,5	3 200	-30...+75	85 000 / 37 500	167 500	2	/2/12		
4182 NXH	237	139,5	12	7...14	57	6,5	■	11,0	4 400	-30...+55	70 000 / 50 000	142 500	3			
4184 NGX	160	94,2	24	12...30	44	5,3	□	3,5	2 800	-10...+75	85 000 / 37 500	167 500	1	/2		
4184 NXM	160	94,2	24	12...30	44	5,3	■	3,5	2 800	-30...+75	85 000 / 37 500	167 500	1			
4184 NX	180	105,9	24	12...29	49	5,7	■	4,5	3 200	-30...+75	85 000 / 37 500	167 500	2	/2/17		
4184 NXH	237	139,5	24	12...25	57	6,5	■	11,0	4 400	-30...+55	70 000 / 50 000	142 500	3	/2		
4188 NGX	160	94,2	48	36...56	44	5,3	□	3,8	2 800	-10...+75	85 000 / 37 500	167 500	1			
4188 NXM	160	94,2	48	36...56	44	5,3	■	3,5	2 800	-30...+75	85 000 / 37 500	167 500	1	/12		

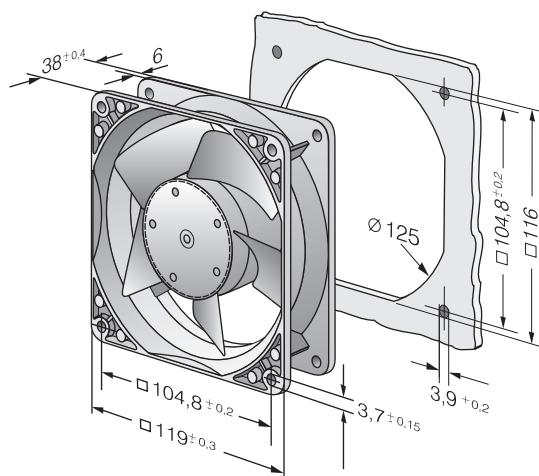
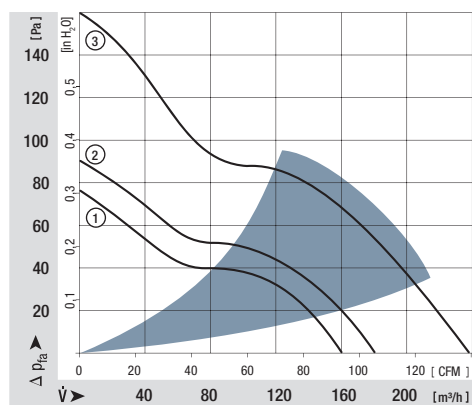

max. 440 m³/h

DC axial fans

Series 4100 N High Performance 119 x 119 x 38 mm



Highlights:

- Very rigid compression curve for high air flow at high back pressure.
- Low operating noise level at high back pressure.
- Optional Vario-Pro: Highly adaptable software configuration of the fan enables a tailor-made solution to the specific requirements of your applications.

General characteristics:

- Material: aluminium housing, fibreglass-reinforced PA impeller; housing with grounding lug for screw M4 x 8 (Torx).
- Fully integrated electronic commutation.
- Protected against reverse polarity and locking.
- Connection via single strands AWG 22, UL1007, TR 64, bared and tin-plated
- Air intake over struts. Direction of rotation clockwise, seen on rotor.
- Mass: 390 g.

Nominal data		Air flow	Air flow	Nominal voltage	Voltage range	Sound pressure level	Sound power level	Sinter sleeve bearings Ball bearings	Power input	Nominal speed	Temperature range	Service life L ₁₀ (40 °C) ebm-papst Standard	Service life L ₁₀ (τ _{max}) ebm-papst Standard	Life expectancy L ₁₀ Δ (40 °C) see P. 15	Curve	Specials
Type		m ³ /h	CFM	VDC	VDC	dB(A)	Bel(A)	□ / ■	Watts	RPM	°C	Hours	Hours		P. 110	
4112 NHH		260	152,9	12	9...15	60	6,8	■	13,3	5 000	-20...+65	70 000 / 55 000	147 500	1		
4112 NH3		310	182,4	12	9...15	65	7,2	■	21,6	6 000	-20...+65	65 000 / 37 500	132 500	2	/2	
4112 NH4		355	208,9	12	9...14	67	7,4	■	32,0	6 800	-20...+65	62 500 / 35 000	125 000	3	/2	
4114 NHH		260	152,9	24	16...30	60	6,8	■	12,4	5 000	-20...+65	70 000 / 52 500	147 500	1	/2	
4114 NH3		310	182,4	24	16...30	65	7,2	■	19,5	6 000	-20...+65	65 000 / 37 500	132 500	2	/2	
4114 NH4		355	208,9	24	16...30	67	7,4	■	30,0	6 800	-20...+65	62 500 / 35 000	125 000	3	/2	
4114 NH5		390	229,5	24	16...30	70	7,6	■	45,0	7 500	-20...+65	62 500 / 35 000	125 000	4	/2	
4114 NH6		440	259,0	24	16...30	73	8,1	■	65,0	8 400	-20...+65	60 000 / 32 500	120 000	5	/2	
4118 NHH		260	152,9	48	36...60	60	6,8	■	12,0	5 000	-20...+65	70 000 / 52 500	147 500	1	/2	
4118 NH3		310	182,4	48	36...60	65	7,2	■	20,0	6 000	-20...+65	65 000 / 37 500	132 500	2	/2	
4118 NH4		355	208,9	48	36...60	67	7,4	■	28,0	6 800	-20...+65	62 500 / 35 000	125 000	3	/2	
4118 NH5		390	229,5	48	36...60	70	7,6	■	45,0	7 500	-20...+65	62 500 / 35 000	125 000	4	/2	
4118 NH6		440	259,0	48	36...60	73	8,1	■	62,0	8 400	-20...+65	60 000 / 32 500	120 000	5	/2	

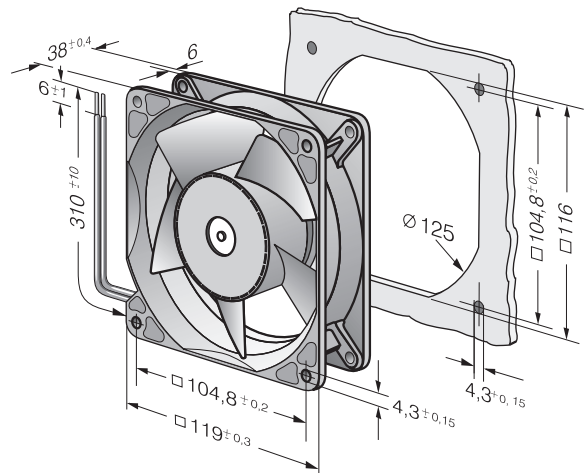
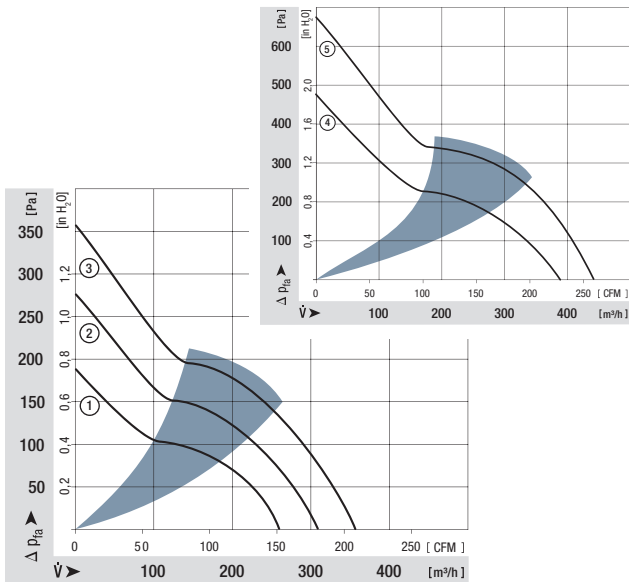

max. 570 m³/h

DC axial fans

Series 4100 N High Performance 119 x 119 x 38 mm



Highlights:

- Very rigid compression curve for high air flow at high back pressure.
- Low operating noise level at high back pressure.
- Available as standard with PWM control input and speed signal, additional inputs and outputs on request. 3-phase fan drive with high degree of running smoothness.

General characteristics:

- Material: aluminium housing, fibreglass-reinforced PA impeller; housing with grounding lug for screw M4 x 8 (Torx).
- Protected against reverse polarity and locking.
- Connection via single strands AWG 20, sensor and control leads AWG 22, UL1007, TR 64. Bared and tin-plated.
- Air intake over struts. Direction of rotation clockwise, seen on rotor.
- Mass: 425 g.

Nominal data		Air flow	Air flow	Nominal voltage	Voltage range	Sound pressure level	Sound power level	Sinter sleeve bearings Ball bearings	Power input	Nominal speed	Temperature range	Service life L ₁₀ (40 °C) ebm-papst Standard	Service life L ₁₀ (T _{max}) ebm-papst Standard	Life expectancy L ₁₀ Δ (40 °C) see P. 15	Curve	Specials
Type		m ³ /h	CFM	VDC	VDC	dB(A)	Bel(A)	■ / ■	Watts	RPM	°C	Hours	Hours	Hours	P. 110	
4114 N/2H7P		500	294,2	24	16...30	76	8,5	■	90	9 500	-20...+75	57 500 / 25 000	115 000	1	/2	
4114 N/2H8P		570	335,5	24	16...30	78	8,9	■	120	11 000	-20...+75	55 000 / 22 500	110 000	2	/2	
4118 N/2H7P		500	294,2	48	36...60*	76	8,5	■	90	9 500	-20...+75	57 500 / 25 000	115 000	1	/2	
4118 N/2H8P		570	335,5	48	36...60*	78	8,9	■	120	11 000	-20...+75	55 000 / 22 500	110 000	2	/2	

*36...72 VDC on request.

Speed control range from 500 RPM up to maximum nominal speed. Stationary at 0 % PWM, maximum speed at sensor break.

To attain the specified service life, an external capacitor must be wired between the plus and minus strands. Please note the wiring suggestion on page 22.

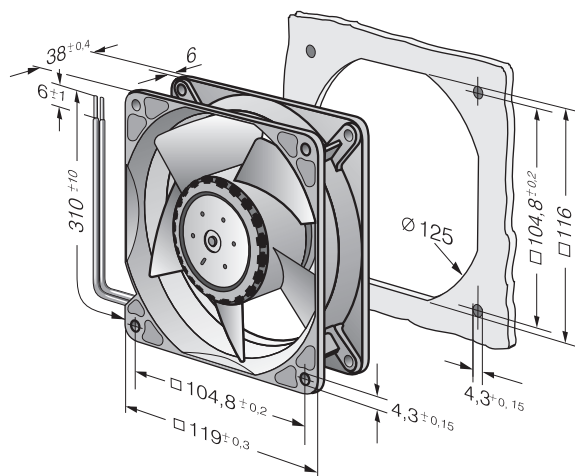
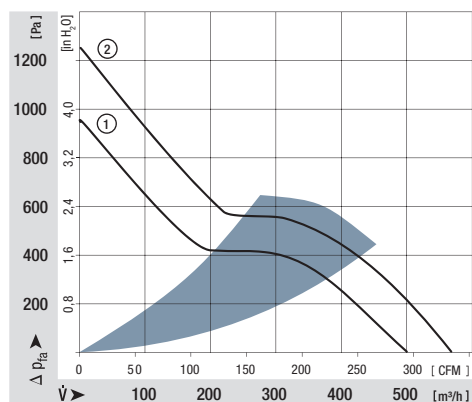

max. 275 m³/h

DC diagonal fans

Series DV 4100 119 x 119 x 38 mm



Highlights:

- Diagonal compact fan with low noise and high pressure saddle.
- Very rigid compression curve for high air flow at high back pressure.
- Optional Vario-Pro: Highly adaptable software configuration of the fan enables a tailor-made solution to the specific requirements of your applications.

General characteristics:

- Material: aluminium housing, fibreglass-reinforced PA impeller; housing with grounding lug for screw M4 x 8 (Torx).
- Fully integrated electronic commutation.
- Protected against reverse polarity and locking.
- Connection via single strands AWG 22, TR 64, bared and tin-plated
- Air exhaust over struts. Direction of rotation counter-clockwise, seen on rotor.
- Mass: 375 g (with aluminium housing : 455 g).

Nominal data		Air flow	Air flow	Nominal voltage	Voltage range	Sound pressure level	Sound power level	Sinter sleeve bearings Ball bearings	Power input	Nominal speed	Temperature range	Service life L ₁₀ (40 °C) ebm-papst Standard	Service life L ₁₀ (T _{max}) ebm-papst Standard	Life expectancy L ₁₀ Δ (40 °C) see P. 15	Curve	Specials
Type		m ³ /h	CFM	VDC	VDC	dB(A)	Bel(A)	■ / ■	Watts	RPM	°C	Hours	Hours	Hours	P. 110	
DV 4112 N		280	164,7	12	9...15	61	6,9	■	21,0	6 000	-20...+65	70 000 / 40 000	142 500	142 500	1	
DV 4114 N		280	164,7	24	16...30	61	6,9	■	20,5	6 000	-20...+65	70 000 / 40 000	142 500	142 500	1	/2
DV 4118 N		280	164,7	48	36...60	61	6,9	■	20,0	6 000	-20...+65	70 000 / 40 000	142 500	142 500	1	

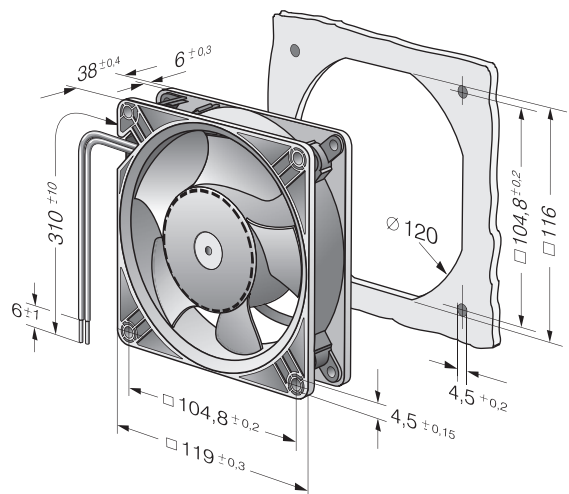
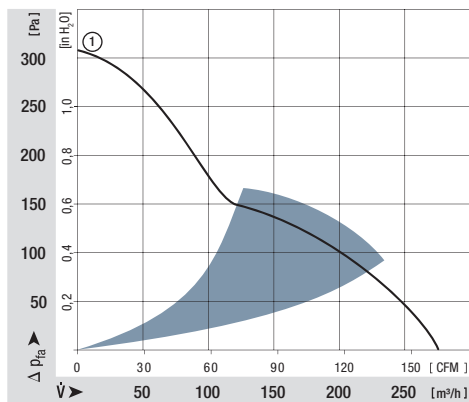

max. 338 m³/h

DC axial fans

Series 5200 N 127 x 127 x 38 mm



Highlights:

- Optional Vario-Pro: Highly adaptable software configuration of the fan enables a tailor-made solution to the specific requirements of your applications.

General characteristics:

- Material: fibreglass-reinforced plastic. Impeller PA, housing PBT.
- Fully integrated electronic commutation.
- Protected against reverse polarity and locking.
- Connection via single strands AWG 22, TR 64. Bared and tin-plated.
- Air exhaust over struts. Direction of rotation counter-clockwise, seen on rotor.
- Mass: 310 g.

Nominal data	Air flow		Nominal voltage	Voltage range	Sound pressure level	Sound power level	Sinter sleeve bearings Ball bearings	Power input	Nominal speed	Temperature range	Service life L ₁₀ (40 °C) ebm-papst Standard	Service life L ₁₀ (T _{max}) ebm-papst Standard	Life expectancy L ₁₀ Δ (40 °C) see P. 15	Curve	Specials
	m ³ /h	CFM													
5212 NM	187	110,1	12	7...14,5	43	5,3	■	4,6	2 750	-20...+75	62 500 / 27 500	122 500	1		
5212 NN	216	127,1	12	7...14	46	5,6	■	6,0	3 150	-20...+75	57 500 / 25 000	112 500	2		
5212 NH	252	148,3	12	7...14	51	6,0	■	9,8	3 650	-20...+70	45 000 / 22 500	90 000	3		
5212 NHH*	340	200,0	12	9...15	58	6,6	■	19,0	4 900	-20...+65	45 000 / 25 000	90 000	4	/2	
5214 NM	187	110,1	24	12...28	43	5,3	■	4,6	2 750	-20...+75	62 500 / 27 500	122 500	1		
5214 NN	216	127,1	24	12...28	46	5,6	■	6,0	3 150	-20...+75	57 500 / 25 000	112 500	2	/2	
5214 NH	252	148,3	24	12...28	51	6,0	■	9,8	3 650	-20...+70	45 000 / 22 500	90 000	3	/2	
5214 NHH*	340	200,0	24	16...30	58	6,6	■	17,5	4 900	-20...+65	45 000 / 25 000	90 000	4	/2	
5218 NM	187	110,1	48	40...56	43	5,3	■	5,0	2 750	-20...+75	62 500 / 27 500	122 500	1		
5218 NN	216	127,1	48	40...56	46	5,6	■	6,5	3 150	-20...+65	57 500 / 32 500	112 500	2		
5218 NH	252	148,3	48	40...56	51	6,0	■	10,0	3 650	-20...+55	45 000 / 32 500	90 000	3		
5218 NHH*	340	200,0	48	36...60	58	6,6	■	18,0	4 900	-20...+65	45 000 / 25 000	90 000	4	/2	

*Models NHH: Fan housing with moulded-in spacers.

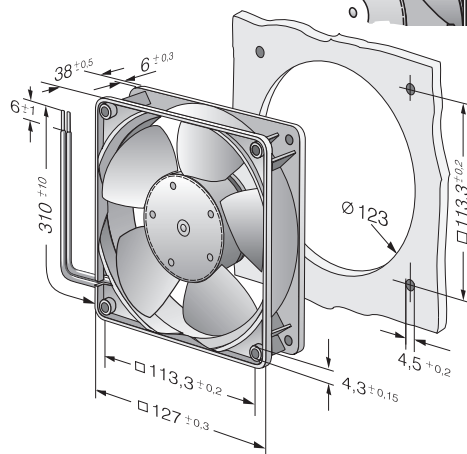
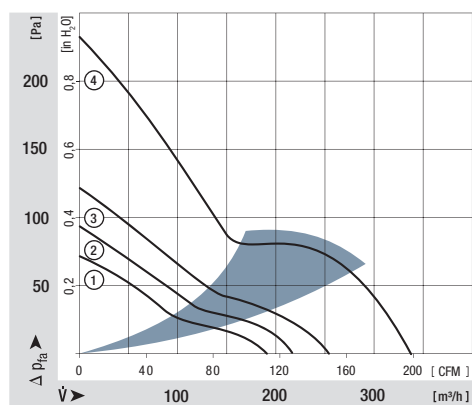
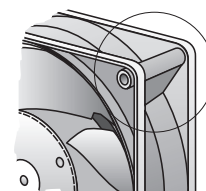

max. 324 m³/h

DC diagonal fans

Series DV 5200 127 x 127 x 38 mm



Highlights:

- Diagonal fan with lower operating noise at high pressures.
- Very rigid compression curve for high air flow at high back pressure.
- Optional Vario-Pro: Highly adaptable software configuration of the fan enables a tailor-made solution to the specific requirements of your applications.
- DV 5214 /2HP with PWM control input and speed signal, additional inputs and outputs on request.

General characteristics:

- Material: housing of fibreglass-reinforced plastic, optionally of aluminium. Metal flange. Impeller of fibreglass-reinforced plastic PA; housing with grounding lug for screw M4 x 8 (Torx).
- Fully integrated electronic commutation. Protected against reverse polarity and locking.
- Connection via single strands AWG 22, TR 64, bared and tin-plated.
- Air exhaust over struts. Direction of rotation counter-clockwise, seen on rotor.
- Mass: 415 g (with metal housing: 490 g).

Nominal data		Air flow	Air flow	Nominal voltage	Voltage range	Sound pressure level	Sound power level	Sinter sleeve bearings Ball bearings	Power input	Nominal speed	Temperature range	Service life L ₁₀ (40 °C) ebm-papst Standard	Service life L ₁₀ (T _{max}) ebm-papst Standard	Life expectancy L ₁₀ Δ (40 °C) see P. 15	Curve	Specials
Type		m ³ /h	CFM	VDC	VDC	dB(A)	Bel(A)	■ / ■	Watts	RPM	°C	Hours	Hours		P. 110	
DV 5212 N		270	158,9	12	9...15	56	6,4	■	21,0	5 000	-20...+65	70 000 / 40 000	142 500	1	/2	
DV 5214 N		270	158,9	24	16...30	56	6,4	■	20,4	5 000	-20...+65	70 000 / 40 000	142 500	1	/2	
DV 5218 N		270	158,9	48	36...60	56	6,4	■	18,5	5 000	-20...+65	70 000 / 40 000	142 500	1	/2	
Model comes standard with speed signal and PWM control input. Other versions by request.																
DV 5214 /2HP		320	188,2	24	16...30	62	7,2	■	38,5	6 000	-20...+65	62 500 / 35 000	125 000*	2		

Speed control range from 1000 RPM up to maximum nominal speed. Stationary at 0 % PWM, maximum speed at sensor break.

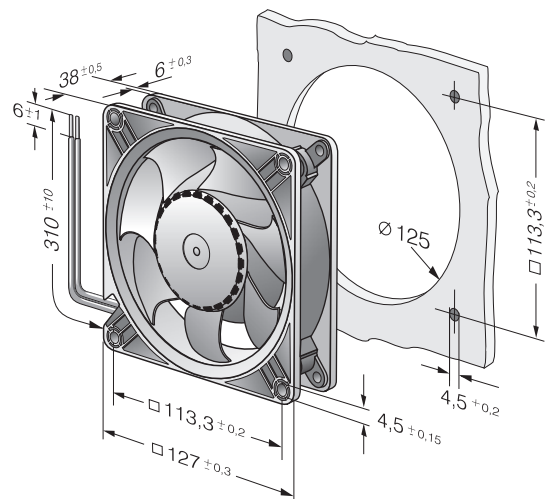
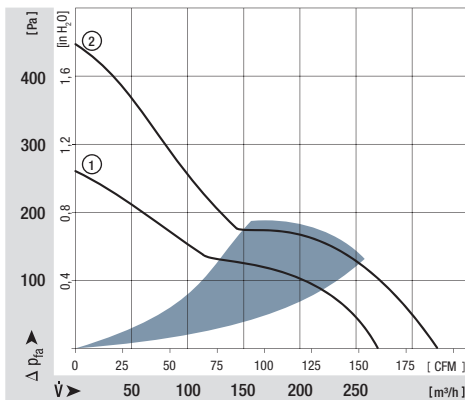

max. 250 m³/h

DC axial fans

Series 5100 N 135 x 135 x 38 mm



General characteristics:

- Material for aluminium housing and impeller; housing with grounding lug for screw M4 x 8 (Torx). 48 V version incl. screws.
- Fully integrated electronic commutation.
- Protected against reverse polarity and locking.
- Connection via single strands AWG 22, TR 64, bared and tin-plated.
- Air exhaust over struts. Direction of rotation counter-clockwise, seen on rotor.
- Mass: 650 g.

Nominal data	Air flow		Nominal voltage	Voltage range	Sound pressure level	Sound power level	Sinter sleeve bearings Ball bearings	Power input	Nominal speed	Temperature range	Service life L ₁₀ (40 °C) ebm-papst Standard	Service life L ₁₀ (T _{max}) ebm-papst Standard	Life expectancy L ₁₀ Δ (40 °C) see P. 15	Curve	Specials
	m ³ /h	CFM													
5112 N	250	147,1	12	6...15	48	6,1	■	9,5	2 900	-25...+72	80 000 / 37 500	157 500	1	/2	
5114 N	250	147,1	24	12...30	48	6,1	■	9,5	2 900	-25...+72	80 000 / 37 500	157 500	1	/2	
5118 N	250	147,1	48	24...60	48	6,1	■	9,5	2 900	-25...+72	80 000 / 37 500	157 500	1	/2/12	

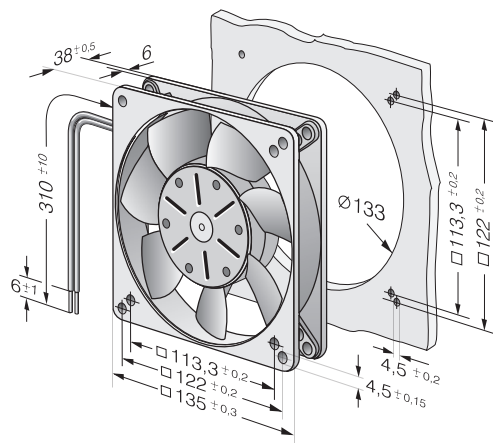
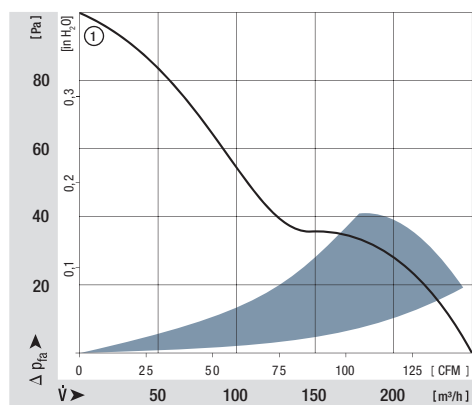

max. 338 m³/h

DC axial fans

Series 5300 140 x 140 x 51 mm

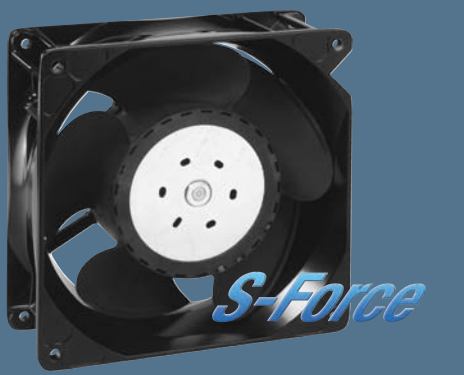

Highlights:

- Very rigid compression curve for high air flow at high back pressure.
- Low operating noise level at high back pressure.
- Available as standard with PWM control input and speed signal. Additional inputs and outputs on request.

General characteristics:

- Material: aluminium housing, fibreglass-reinforced PA impeller; housing with grounding lug for screw M4 x 8 (Torx).
- Protected against reverse polarity and locking.
- Connection via single strands AWG 22, TR 64. Bared and tin-plated.
- Air intake over struts. Direction of rotation counter-clockwise, seen on rotor.
- Mass: 900 g.

Nominal data		Air flow	Air flow	Nominal voltage	Voltage range	Sound pressure level	Sound power level	Sinter sleeve bearings Ball bearings	Power input	Nominal speed	Temperature range	Service life L ₁₀ (40 °C) ebm-papst Standard	Service life L ₁₀ (T _{max}) ebm-papst Standard	Life expectancy L ₁₀ Δ (40 °C) see P. 15	Curve	Specials
Type		m ³ /h	CFM	VDC	VDC	dB(A)	Bel(A)	□ / ■	Watts	RPM	°C	Hours	Hours			
NEW	5314 /2HP	340	200	24	16...28	64	7,2	■	28,4	5 000	-20...+65	77 500/40 000	160 000		1	
NEW	5318 /2HP	340	200	48	36...72	64	7,2	■	27	5 000	-20...+65	77 500/40 000	160 000		1	

Speed control range from 700 RPM up to maximum nominal speed. Stationary at 0 % PWM, maximum speed at sensor break.

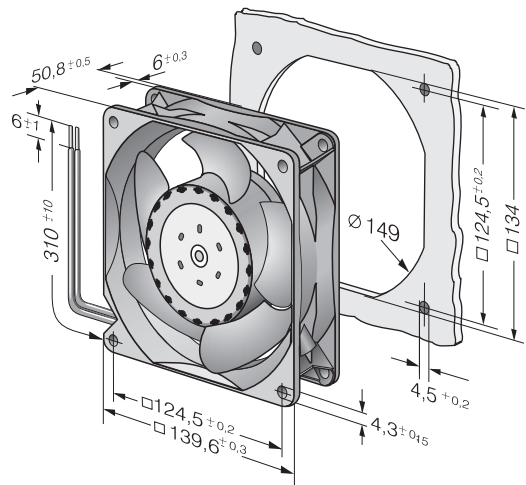
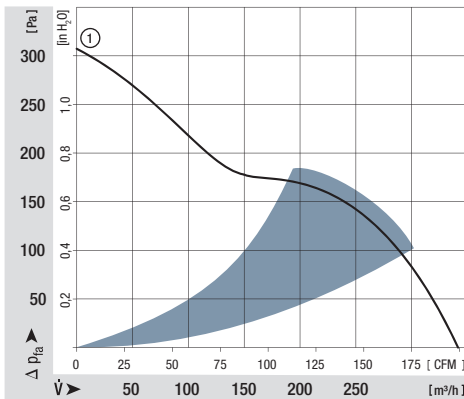

max. 670 m³/h

DC axial fans

Series 5300 TD 140 x 140 x 51 mm



Highlights:

- 3-phase fan drive with high degree of running smoothness.
- Very rigid compression curve for high air flow at high back pressure.
- Low operating noise level at high back pressure.
- Standard with PWM control input and speed signal, additional inputs and outputs on request.

General characteristics:

- Material: aluminium housing, fibreglass-reinforced PA impeller; housing with grounding lug for screw M4 x 8 (Torx).
- Protected against reverse polarity and locking.
- Connection via single strands AWG 20, TR 64. Bared and tin-plated.
- Air intake over struts. Direction of rotation counter-clockwise, seen on rotor.
- Mass: 900 g.

Nominal data		Air flow	Air flow	Nominal voltage	Voltage range	Sound pressure level	Sound power level	Sinter sleeve bearings Ball bearings	Power input	Nominal speed	Temperature range	Service life L ₁₀ (40 °C) ebm-papst Standard	Service life L ₁₀ (T _{max}) ebm-papst Standard	Life expectancy L ₁₀ Δ (40 °C) see P. 15	Curve	Specials
Type		m ³ /h	CFM	VDC	VDC	dB(A)	Bel(A)	□ / ■	Watts	RPM	°C	Hours	Hours	Hours	1	P. 110
5312 /2 TDHP		410	241,3	12	8...16	70	7,7	■	43	6 000	-20...+70	70 000 / 35 000	140 000	140 000	1	/2
5314 /2 TDHP		410	241,3	24	16...36	70	7,7	■	42	6 000	-20...+70	70 000 / 35 000	140 000	140 000	1	/2
5314 /2 TDHHP		490	288,4	24	16...36	75	8,1	■	67	7 000	-20...+70	62 500 / 30 000	120 000	120 000	2	/2
5318 /2 TDHP		410	241,3	48	36...72	70	7,7	■	42	6 000	-20...+70	70 000 / 35 000	140 000	140 000	1	/2
5318 /2 TDHHP		490	288,4	48	36...72	75	8,1	■	66	7 000	-20...+70	62 500 / 30 000	120 000	120 000	2	/2
5318 /2 TDH4P		670	394,3	48	36...72	79	8,8	■	149	9 200	-20...+65	57 500 / 32 500	115 000	115 000	3	/2

Speed control range from 1000 RPM up to maximum nominal speed. Stationary at 0 % PWM, maximum speed at sensor break.

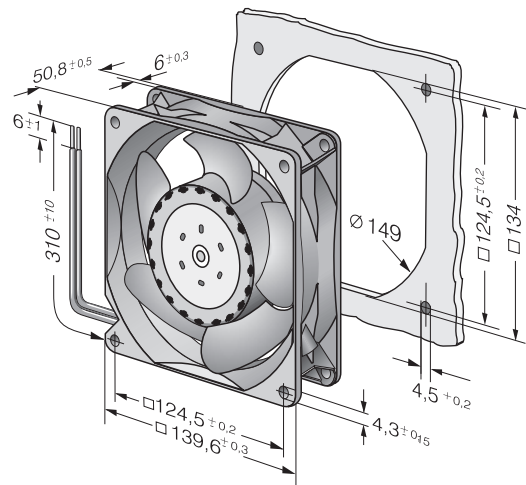
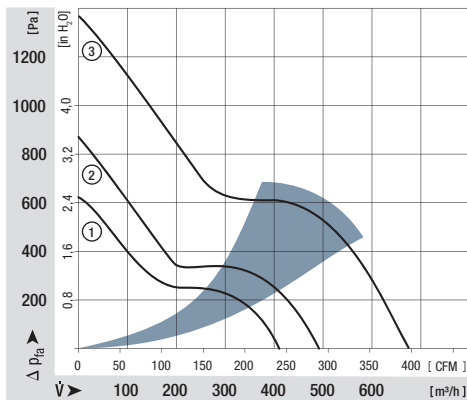

max. 420 m³/h

DC axial fans

Series 7100 N 150 Ø x 38 mm



General characteristics:

- Material: Aluminium housing and impeller; housing with grounding lug for screw M4 x 8 (Torx).
- Fully integrated electronic commutation.
- Protected against reverse polarity and locking.
- Connection via single strands AWG 22, TR 64, bared and tin-plated.
- Air intake over struts. Direction of rotation counter-clockwise, seen on rotor.
- Mass: 620 g.

Nominal data		Air flow	Air flow	Nominal voltage	Voltage range	Sound pressure level	Sound power level	Sinter sleeve bearings Ball bearings	Power input	Nominal speed	Temperature range	Service life L ₁₀ (40 °C) ebm-papst Standard	Service life L ₁₀ (T _{max}) ebm-papst Standard	Life expectancy L ₁₀ Δ (40 °C, see P. 15)	Curve	Specials
Type	m ³ /h	CFM	VDC	VDC	dB(A)	Bel(A)	■ / ■	Watts	RPM	°C	Hours	Hours	Hours	P. 110		
7112 N	360	211,9	12	6...15	55	6,5	■	12,0	2 850	-25...+72	80 000 / 37 500	157 500	1	/2		
7114 N	360	211,9	24	12...30	55	6,5	■	12,0	2 850	-25...+72	80 000 / 37 500	157 500	1	/2		
7114 NH	420	247,2	24	12...26,5	59	7,0	■	19,0	3 350	-25...+72	75 000 / 35 000	147 500	2			
7118 N	360	211,9	48	24...60	55	6,5	■	12,0	2 850	-25...+72	80 000 / 37 500	157 500	1	/2		

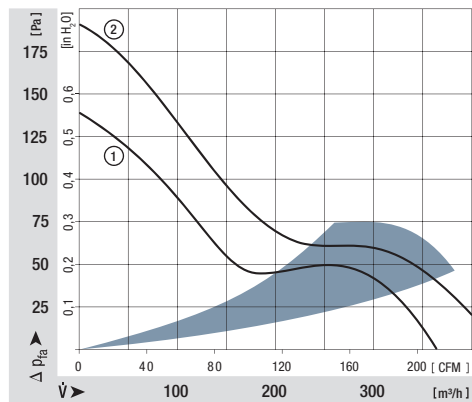

Strand fastened using cable tie;
cable tie protrudes 1 mm.

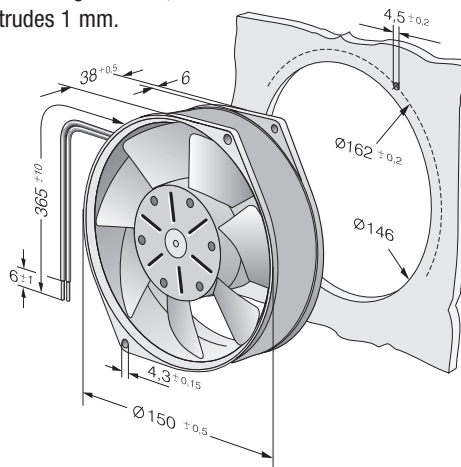

max. 360 m³/h

DC axial fans

Series 7200 N 150 Ø x 55 mm



Highlights:

- Optional Vario-Pro: Highly adaptable software configuration of the fan enables a tailor-made solution to the specific requirements of your applications.

General characteristics:

- Material: aluminium housing, fibreglass-reinforced PA impeller; housing with grounding lug for screw M4 x 8 (Torx).
- Fully integrated electronic commutation.
- Protected against reverse polarity and locking.
- Connection via single strands AWG 22, TR 64, bared and tin-plated.
- Air exhaust over struts. Direction of rotation counter-clockwise, seen on rotor.
- Mass: 725 g.

Nominal data	Air flow		Nominal voltage	Voltage range	Sound pressure level	Sound power level	Sinter sleeve bearings Ball bearings	Power input	Nominal speed	Temperature range	Service life L ₁₀ (40 °C) ebm-papst Standard	Service life L ₁₀ (T _{max}) ebm-papst Standard	Life expectancy L ₁₀ Δ (40 °C), see P. 15	Curve	Specials
	m ³ /h	CFM													
7212 N	360	211,9	12	6...15	53	6,2	■	12,0	3 050	-25...+72	80 000 / 37 500	157 500	1	/2	
7214 N	360	211,9	24	12...30	53	6,2	■	12,0	3 050	-25...+72	80 000 / 37 500	157 500	1	/12/17/19	
7218 N	360	211,9	48	24...60	53	6,2	■	12,0	3 050	-25...+72	80 000 / 37 500	157 500	1		

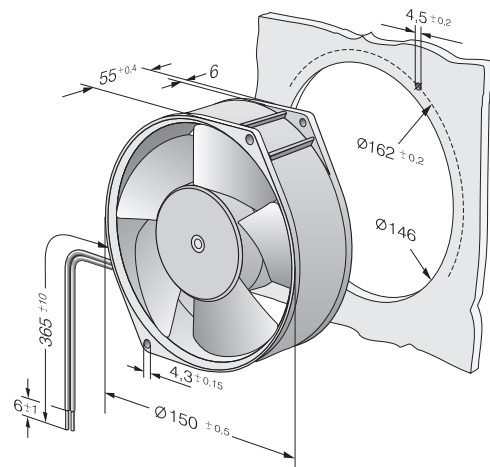
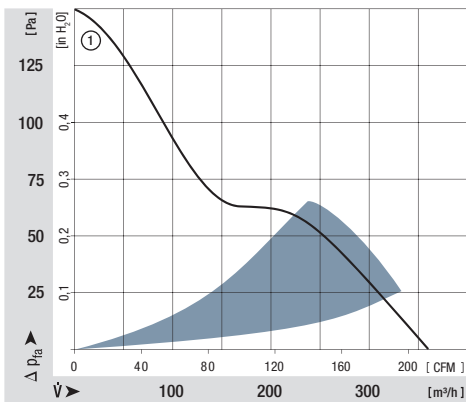

max. 350 m³/h

DC axial fans

Series 6100 N 172 x 160 x 52 mm



Highlights:

- Compact, lightweight plastic housing.
- VARIOFAN models available with external temperature sensor.
- Optional Vario-Pro: Highly adaptable software configuration of the fan enables a tailor-made solution to the specific requirements of your applications.
- Open loop speed control, sensor and alarm signal available on request.

General characteristics:

- Material: housing and impeller of fibreglass-reinforced PA.
- Fully integrated electronic commutation.
- Protected against locking.
- Connection via single strands AWG 22, TR 64. Bared and tin-plated.
- Air exhaust over struts. Direction of rotation counter-clockwise, seen on rotor.
- Mass: 610 g.

Nominal data		Air flow	Air flow	Nominal voltage	Voltage range	Sound pressure level	Sound power level	Sintec sleeve bearings Ball bearings	Power input	Nominal speed	Temperature range	Service life L ₁₀ (40 °C) ebm-papst Standard	Service life L ₁₀ (T _{max}) ebm-papst Standard	Life expectancy L ₁₀ Δ (40 °C, see P. 15)	Curve	Specials
Type		m ³ /h	CFM	VDC	VDC	dB(A)	Bel(A)	■ / ■	Watts	RPM	°C	Hours	Hours	Hours		
NEW	6112 NM	350	206	12	8...15	49	5,9	■	11	2 850	-20...+70	80 000/37 500	157 500	1		
NEW	6114 NM	350	206	24	12...32	49	5,9	■	11	2 850	-20...+70	80 000/37 500	157 500	1		

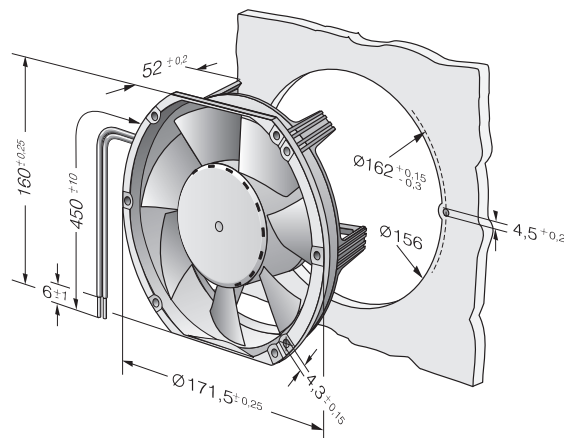
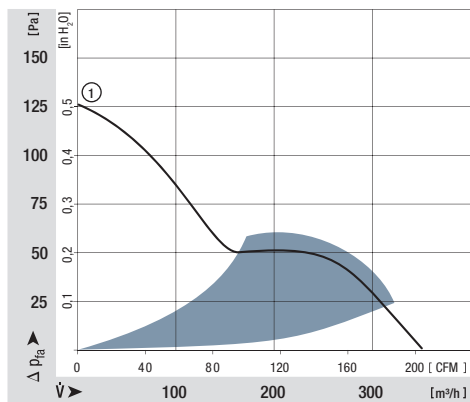

max. 545 m³/h

DC axial fans

Series 6300 172 Ø x 51 mm



Highlights:

- Very rigid compression curve for high air flow at high back pressure.
- Low operating noise level at high back pressure.
- Available as standard with PWM control input and speed signal. Additional inputs and outputs on request.

General characteristics:

- Material: aluminium housing, fibreglass-reinforced PA impeller; housing with grounding lug for screw M4 x 8 (Torx).
- Protected against reverse polarity and locking.
- Connection via single strands AWG 22, TR 64. Bared and tin-plated.
- Air exhaust over struts. Direction of rotation counter-clockwise, seen on rotor.
- Mass: 910 g.

Nominal data		Air flow	Air flow	Nominal voltage	Voltage range	Sound pressure level	Sound power level	Sinter sleeve bearings Ball bearings	Power input	Nominal speed	Temperature range	Service life L ₁₀ (40 °C) ebm-papst Standard	Service life L ₁₀ (T _{max}) ebm-papst Standard	Life expectancy L ₁₀ Δ (40 °C) see P. 15	Curve	Specials
Type		m ³ /h	CFM	VDC	VDC	dB(A)	Bel(A)	■ / ■	Watts	RPM	°C	Hours	Hours	Hours		
NEW	6314 /2MP	395	232,4	24	16...30	51	6,0	■	13	3 600	-20...+75	82 500/32 500	165 000	1		
NEW	6314 /2NP	470	276,5	24	16...30	56	6,5	■	23	4 400	-20...+70	80 000/40 000	160 000	2		
NEW	6314 /2HP	545	320,6	24	16...30	58	6,9	■	31	5 000	-20...+65	77 500/42 500	155 000	3		
NEW	6318 /2HP	545	320,6	48	36...72	58	6,9	■	32	5 000	-20...+65	77 500/42 500	155 000	3		

Speed control range from 700 RPM up to maximum nominal speed. Stationary at 0 % PWM, maximum speed at sensor break.

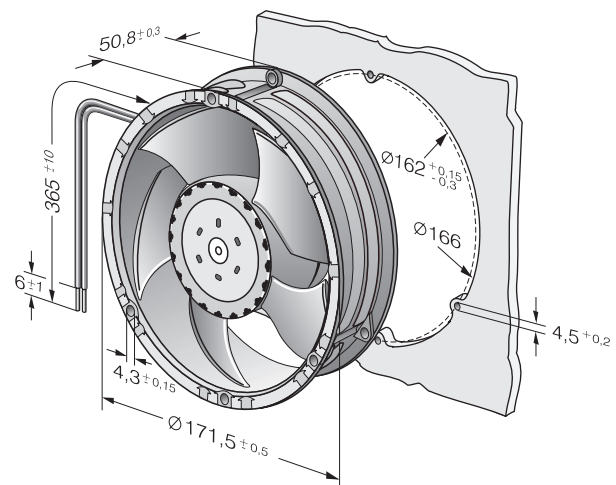
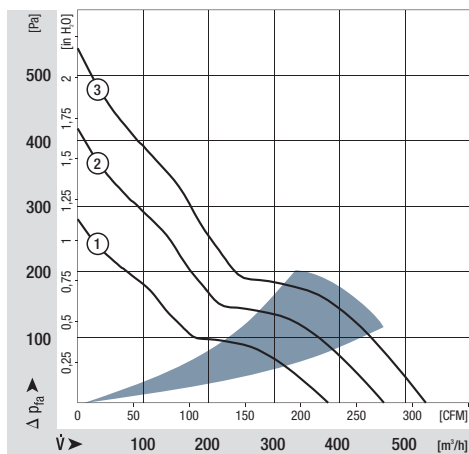

max. 950 m³/h

DC axial fans

Series 6300 TD 172 Ø x 51 mm



Highlights:

- 3-phase fan drive high degree of running smoothness.
- Very rigid compression curve for high air flow at high back pressure.
- Low operating noise level at high back pressure.
- Standard with PWM control input and speed signal, additional inputs and outputs on request.

General characteristics:

- Material: aluminium housing, fibreglass-reinforced PA impeller; housing with grounding lug for screw M4 x 8 (Torx).
- Protected against reverse polarity and locking.
- Connection via single strands AWG 20, TR 64. Bared and tin-plated.
- Air exhaust over struts. Direction of rotation counter-clockwise, seen on rotor.
- Mass: 910 g.

Nominal data		Air flow	Air flow	Nominal voltage	Voltage range	Sound pressure level	Sound power level	Sinter sleeve bearings Ball bearings	Power input	Nominal speed	Temperature range	Service life L ₁₀ (40 °C) ebm-papst Standard	Service life L ₁₀ (T _{max}) ebm-papst Standard	Life expectancy L ₁₀ ^Δ (40 °C) see P. 15	Curve	Specials
Type		m ³ /h	CFM	VDC	VDC	dB(A)	Bel(A)	■ / ■	Watts	RPM	°C	Hours	Hours			P. 110
6312 /2TDHP		600	353,1	12	8...16	60	7,3	■	40	5 500	-20...+70	75 000 / 37 500	150 000	1	/2	
NEW 6314 /2TDHP-298		600	353,1	24	16...28	60	7,3	■	42	5 500	-20...+65	75 000 / 42 500	150 000	1		
NEW 6314 /2TDHP		600	353,1	24	16...36	60	7,3	■	40	5 500	-20...+70	75 000 / 37 500	150 000	1	/2	
6314 /2TDHHP		710	417,9	24	16...36	69	7,9	■	67	7 000	-20...+70	62 500 / 30 000	120 000	2	/2	
NEW 6318 /2TDHP-299		600	353,1	48	36...56	60	7,3	■	42	5 500	-20...+65	75 000 / 42 500	150 000	1		
NEW 6318 /2TDHP		600	353,1	48	36...72	60	7,3	■	40	5 500	-20...+70	75 000 / 37 500	150 000	1	/2	
6318 /2TDHHP		710	417,9	48	36...72	69	7,9	■	67	7 000	-20...+70	62 500 / 30 000	120 000	2	/2	
6318 /2TDH4P		950	559,1	48	36...72	75	8,4	■	150	9 200	-20...+65	52 500 / 30 000	107 500	3	/2	

Speed control range from 1000 RPM up to maximum nominal speed. Stationary at 0 % PWM, maximum speed at sensor break.

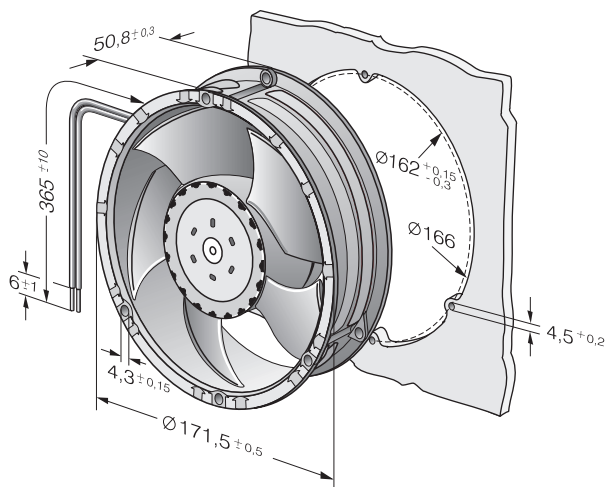
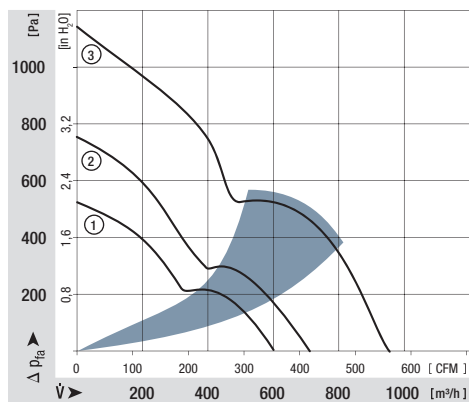

max. 950 m³/h

DC axial fans

Series 6300 TD 172 x 160 x 51 mm



Highlights:

- 3-phase fan drive with high degree of running smoothness.
- Very rigid compression curve for high air flow at high back pressure.
- Low operating noise level at high back pressure.
- Standard with PWM control input and speed signal, additional inputs and outputs on request.

General characteristics:

- Material: aluminium housing, fibreglass-reinforced PA impeller; housing with grounding lug for screw M4 x 8 (Torx).
- Protected against reverse polarity and locking.
- Connection via single strands AWG 20, TR 64. Bared and tin-plated.
- Air exhaust over struts. Direction of rotation counter-clockwise, seen on rotor.
- Mass: 910 g.

Nominal data		Air flow	Air flow	Nominal voltage	Voltage range	Sound pressure level	Sound power level	Sinter sleeve bearings Ball bearings	Power input	Nominal speed	Temperature range	Service life L ₁₀ (40 °C) ebm-papst Standard	Service life L ₁₀ (T _{max}) ebm-papst Standard	Life expectancy L ₁₀ Δ (40 °C)	Curve	Specials
Type		m ³ /h	CFM	VDC	VDC	dB(A)	Bel(A)	□ / ■	Watts	RPM	°C	Hours	Hours	Hours		
NEW	6314 /2TDHHP-015	710	415,0	24	16...36	69	7,9	■	67	7 000	-20...+70	62 500 / 30 000	120 000	120 000	1	
NEW	6318 /2TDH4P-007	950	560,0	48	36...72	75	8,4	■	150	9 200	-20...+65	52 500 / 30 000	107 500	107 500	2	

Speed control range from 1000 RPM up to maximum nominal speed. Stationary at 0 % PWM, maximum speed at sensor break.

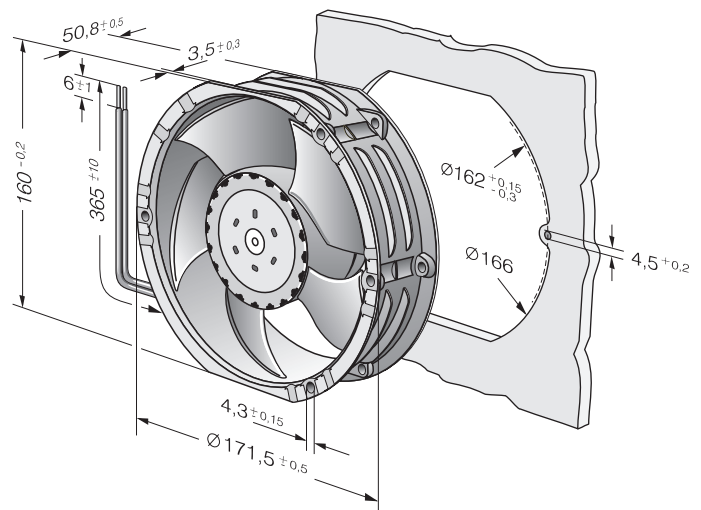
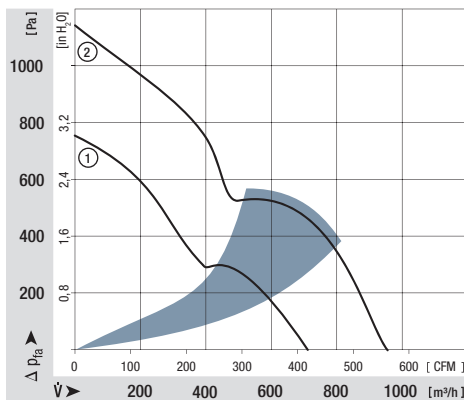

max. 540 m³/h

DC diagonal fans

Series DV 6200 172 Ø x 51 mm



Highlights:

- Diagonal compact fan with low noise and high pressure saddle.
- Very rigid compression curve for high air flow at high back pressure.

General characteristics:

- Material: aluminium housing, fibreglass-reinforced PA impeller; housing with grounding lug for screw M4 x 8 (Torx). 48 V version incl. screws.
- Fully integrated electronic commutation.
- Protected against reverse polarity and locking.
- Connection via single strands AWG 22, TR 64. Bared and tin-plated.
- Air exhaust over struts. Direction of rotation counter-clockwise, seen on rotor.
- Mass: 820 g.

Nominal data		Air flow	Air flow	Nominal voltage	Voltage range	Sound pressure level	Sound power level	Sinter sleeve bearings Ball bearings	Power input	Nominal speed	Temperature range	Service life L ₁₀ (40 °C) ebm-papst Standard	Service life L ₁₀ (T _{max}) ebm-papst Standard	Life expectancy L ₁₀ ^Δ (40 °C) see P. 15	Curve	Specials
Type		m ³ /h	CFM	VDC	VDC	dB(A)	Bel(A)	□ / ■	Watts	RPM	°C	Hours	Hours	Hours		P. 110/112
DV 6224		540	317,8	24	16...28	63	7,1	■	40,0	4 300	-20...+75	90 000 / 40 000	180 000	180 000	1	/2/12
DV 6248		540	317,8	48	28...60	63	7,1	■	40,0	4 300	-20...+75	90 000 / 40 000	180 000	180 000	1	

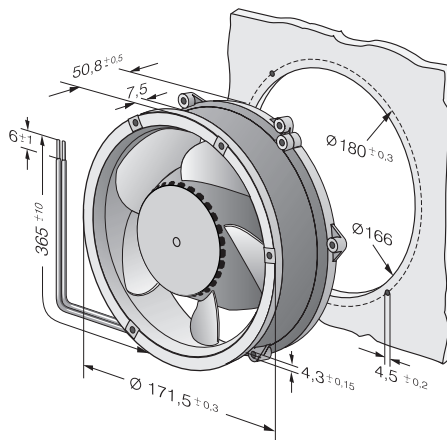
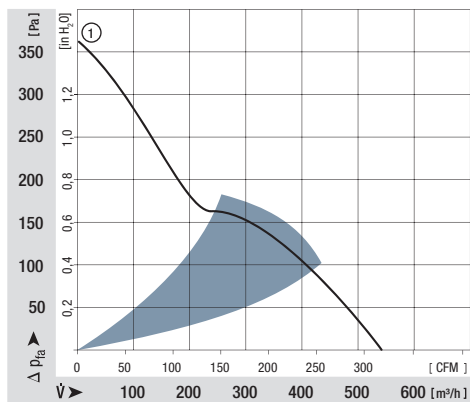

max. 700 m³/h

DC diagonal fans

Series DV 6200 TD TURBOFAN 172 Ø x 51 mm



Highlights:

- Diagonal compact fan with low noise and high pressure saddle.
- 3-phase fan drive with high degree of running smoothness.
- Very rigid compression curve for high air flow at high back pressure.
- Control inputs, alarm and speed signals available on request.

General characteristics:

- Material: aluminium housing, fibreglass-reinforced PA impeller; housing with grounding lug for screw M4 x 8 (Torx). 48 V version incl. screws.
- Fully integrated electronic commutation.
- Connection via single strands AWG 22, TR 64. Bared and tin-plated.
- Air exhaust over struts. Direction of rotation counter-clockwise, seen on rotor.
- Mass: 820 g.

Nominal data		Air flow		Nominal voltage	Voltage range	Sound pressure level	Sound power level	Sinter sleeve bearings Ball bearings	Power input	Nominal speed	Temperature range	Service life L ₁₀ (40 °C) ebm-papst Standard	Service life L ₁₀ (T _{max}) ebm-papst Standard	Life expectancy L ₁₀ Δ (40 °C) see P. 15	Curve	Specials
Type	m ³ /h	CFM	VDC	VDC	dB(A)	Bel(A)	■ / ■	Watts	RPM	°C	Hours	Hours	Hours	P.		
DV 6224 TD	700	421,0	24	16...36	69	7,8	■	89,0	5 500	-20...+60	65 000 / 40 000	130 000	2			
DV 6248 TD	700	421,0	48	40...55	69	7,8	■	89,0	5 500	-20...+60	65 000 / 40 000	130 000	2			
min max	DV 6224 TD...	100	58,9	24	16...36	29	—	2,0	800	-20...+60	65 000	130 000	1	P. 110-116 and 120, 121,123		
		700	421,0												2	
min max	DV 6248 TD...	100	58,9	48	40...55*	29	—	2,0	800	-20...+60	65 000 / 40 000	130 000	1	P. 110-116 and 120, 121,123		
		700	421,0												2	

*Fan with extended voltage range available on request.

Models DV 6224 TD... and DV 6248 TD... are available in customer-specific, custom-developed variants only.

The data specified here are technically feasible benchmark values. The fans can be specially adapted to your application with signal outputs and control inputs.

For details of the technical possibilities, refer to the chapters on the sensor signal, alarm signal and control inputs beginning on page 107.

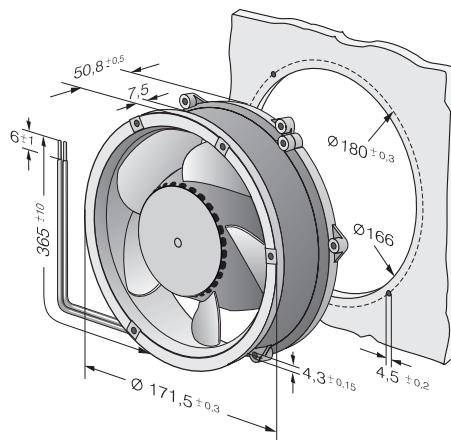
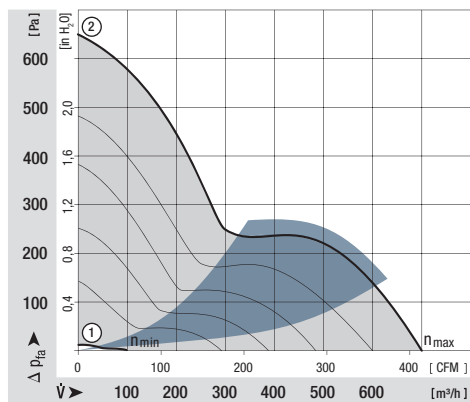

max. 480 m³/h

DC axial fans

Series 6400 172 x 150 x 51 mm



Highlights:

- Optional Vario-Pro: Highly adaptable software configuration of the fan enables a tailor-made solution to the specific requirements of your applications.

General characteristics:

- Material: aluminium housing, fibreglass-reinforced PA impeller; housing with grounding lug for screw M4 x 8 (Torx). 48 V version incl. screws.
- Fully integrated electronic commutation.
- Protected against reverse polarity and locking.
- Electrical connection with flat plugs 3 x 0.5 mm.
- Air exhaust over struts. Direction of rotation counter-clockwise, seen on rotor.
- Mass: 760 g.

Nominal data		Air flow	Air flow	Nominal voltage	Voltage range	Sound pressure level	Sound power level	Sinter sleeve bearings Ball bearings	Power input	Nominal speed	Temperature range	Service life L ₁₀ (40 °C) ebm-papst Standard	Service life L ₁₀ (T _{max}) ebm-papst Standard	Life expectancy L ₁₀ ^Δ (40 °C) see P. 15	Curve	Specials
Type	m ³ /h	CFM	VDC	VDC	dB(A)	Bel(A)	■ / ■	Watts	RPM	°C	Hours	Hours	Hours	P. 110/112		
6412 M	350	206,0	12	8...15	52	6,0	■	12,0	2 850	-20...+72	80 000 / 37 500	157 500	1			
6424 M	350	206,0	24	12...32	52	6,0	■	12,0	2 850	-20...+72	80 000 / 37 500	157 500	1			
6424	410	241,3	24	12...28	57	6,4	■	18,0	3 400	-20...+72	75 000 / 35 000	125 000	2	/2		
6424 H	480	282,5	24	12...28	63	7,1	■	26,0	4 000	-20...+55*	70 000 / 50 000	110 000	3	/12		
6448	410	241,3	48	28...60	57	6,4	■	17,0	3 400	-20...+72	75 000 / 35 000	125 000	2			
6448 H*	480	282,5	48	28...60	63	7,1	■	26,0	4 000	-20...+55**	70 000 / 50 000	110 000	3			

* Leads 310 mm.

** 72 °C upon request.

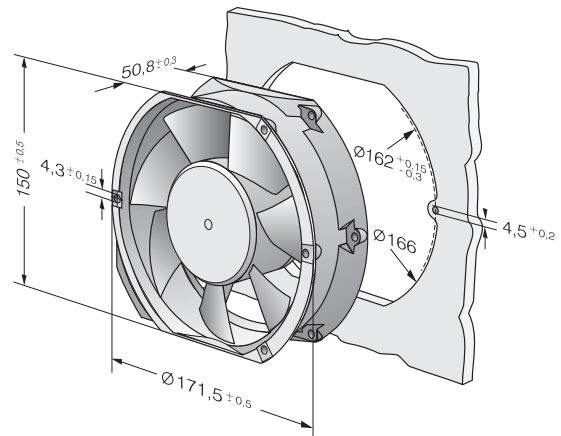
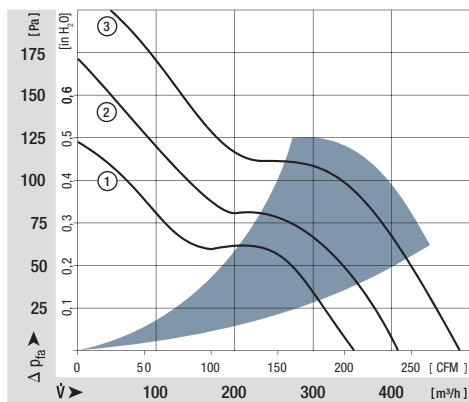

max. 900 m³/h

DC axial fans

Series 6400 TD TURBOFAN 172 x 150 x 51 mm



Highlights:

- 3-phase fan drive with high degree of running smoothness.
- Very rigid compression curve for high air flow at high back pressure.
- Control inputs, alarm and speed signals available on request.
- Optionally available with reversible speed.

General characteristics:

- Material: aluminium housing, fibreglass-reinforced PA impeller; housing with grounding lug for screw M4 x 8 (Torx). 48 V version incl. screws.
- Fully integrated electronic commutation.
- Connection via single strands AWG 22, TR 64. Bared and tin-plated.
- Air exhaust over struts. Direction of rotation counter-clockwise, seen on rotor. Direction of rotation reversible.
- Mass: 760 g.

Nominal data		Air flow		Nominal voltage	Voltage range	Sound pressure level	Sound power level	Sinter sleeve bearings Ball bearings	Power input	Nominal speed	Temperature range	Service life L ₁₀ (40 °C) ebm-papst Standard	Service life L ₁₀ (T _{max}) ebm-papst Standard	Life expectancy L ₁₀ Δ (40 °C) see P. 15	Curve	Specials
Type	m ³ /h	CFM	VDC	VDC	dB(A)	Bel(A)	□ / ■	Watts	RPM	°C	Hours	Hours	Hours	P.		
min max	6424 TD...	90	53,0	24	16...28	18	—	■	2,0	800	-20...+60	70 000 / 45 000	110 000	1	2	
	600	353,1	65													7,4
min max	6448 TD...	90	53,0	48	40...55*	18	—	■	2,0	800	-20...+60	70 000 / 45 000	110 000	1	P. 110-116 and 120, 121,123	
	600	353,1	65													7,4
min max	6448 TDHH...	90	53,0	48	36...72	18	—	■	2,0	800	-20...+60	70 000 / 45 000	110 000	1	P. 110-116 and 120, 121,123	
	900	529,7	78													8,6

*Fan with extended voltage range available on request.

Models DV 6224 TD... and DV 6248 TD... are available in customer-specific, custom-developed variants only. The data specified here are technically feasible benchmark values. The fans can be specially adapted to your application with signal outputs and control inputs. For details of the technical possibilities, refer to the chapters on the sensor signal, alarm signal and control inputs beginning on page 108.

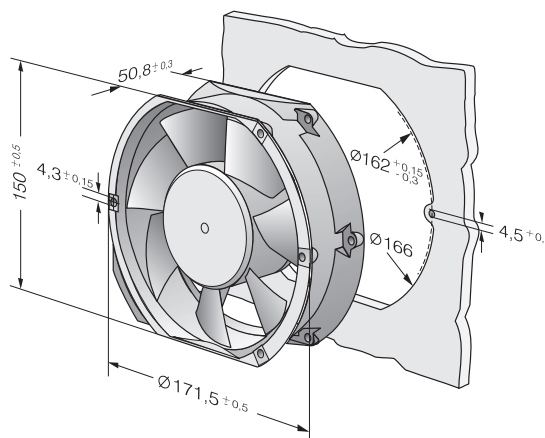
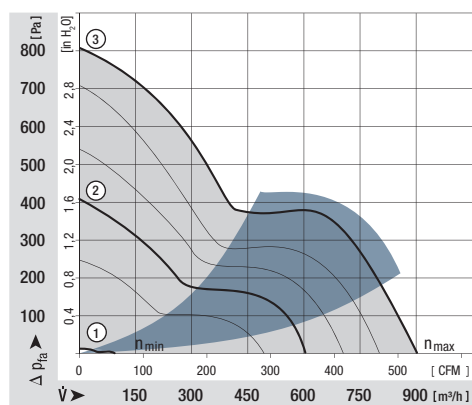

max. 530 m³/h

DC diagonal fans

Series DV 6400 172 x 160 x 51 mm



Highlights:

- Diagonal compact fan with low noise and high pressure saddle.
- Very rigid compression curve for high air flow at high back pressure.
- Optional Vario-Pro: Highly adaptable software configuration of the fan enables a tailor-made solution to the specific requirements of your applications.

General characteristics:

- Material: aluminium housing, fibreglass-reinforced PA impeller; housing with grounding lug for screw M4 x 8 (Torx). 48 V version incl. screws.
- Fully integrated electronic commutation.
- Protected against reverse polarity and locking.
- Connection via single strands AWG 22, TR 64. Bared and tin-plated.
- Air exhaust over struts. Direction of rotation counter-clockwise, seen on rotor.
- Mass: 820 g.

Nominal data		Air flow	Air flow	Nominal voltage	Voltage range	Sound pressure level	Sound power level	Sinter sleeve bearings Ball bearings	Power input	Nominal speed	Temperature range	Service life L ₁₀ (40 °C) ebm-papst Standard	Service life L ₁₀ (T _{max}) ebm-papst Standard	Life expectancy L ₁₀ ^Δ (40 °C) see P. 15	Curve	Specials
Type		m ³ /h	CFM	VDC	VDC	dB(A)	Bel(A)	■ / ■	Watts	RPM	°C	Hours	Hours	Hours	P. 112	
DV 6424		530	311,9	24	16...28	65	7,3	■	40,0	4 300	-20...+75	90 000 / 45 000	180 000	180 000	1	/12
DV 6448		530	311,9	48	28...60	65	7,3	■	40,0	4 300	-20...+75	90 000 / 45 000	180 000	180 000	1	/12

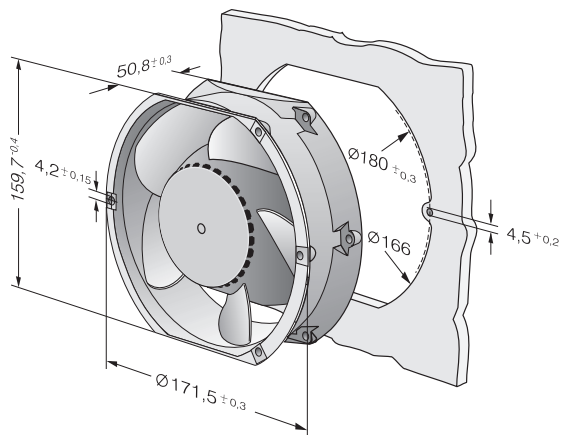
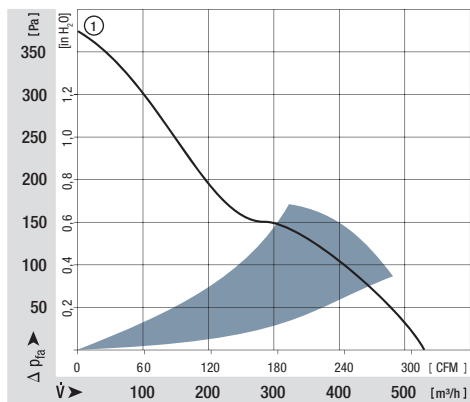

max. 680 m³/h

DC diagonal fans

Series DV 6400 TD TURBOFAN 172 x 160 x 51 mm



Highlights:

- Diagonal compact fan with low noise and high pressure saddle.
- 3-phase fan drive with high degree of running smoothness.
- Very rigid compression curve for high air flow at high back pressure.
- Control inputs, plus alarm and speed signals available on request.
- Optionally available with reversible speed.

General characteristics:

- Material: aluminium housing, fibreglass-reinforced PA impeller; housing with grounding lug for screw M4 x 8 (Torx). 48 V version incl. screws.
- Fully integrated electronic commutation.
- Connection via single strands AWG 22, TR 64. Bared and tin-plated.
- Air exhaust over struts. Direction of rotation counter-clockwise, seen on rotor. Direction of rotation reversible.
- Mass: 820 g.

Nominal data		Air flow		Nominal voltage	Voltage range	Sound pressure level	Sound power level	Sinter sleeve bearings Ball bearings	Power input	Nominal speed	Temperature range	Service life L ₁₀ (40 °C) ebm-papst Standard	Service life L ₁₀ (T _{max}) ebm-papst Standard	Life expectancy L ₁₀ Δ (40 °C) see P. 15	Curve	Specials
Type	m ³ /h	CFM	VDC	VDC	dB(A)	Bel(A)	■ / ■	Watts	RPM	°C	Hours	Hours	Hours	P.		
DV 6424 TD	680	400,2	24	16...28	71	7,9	■	91,0	5 500	-20...+60	65 000 / 40 000	130 000	2			
min max	DV 6424 TD...	100	58,9	24	16...28	71	■	2,0	800	-20...+60	65 000 / 40 000	130 000	1	P. 110-116 and 120, 121,123		
		680	400,2					91,0	5 500							
min max	DV 6448 TD...	100	58,9	48	40...55	71	■	2,0	800	-20...+60	65 000 / 40 000	130 000	1	P. 110-116 and 120, 121,123		
		680	400,2					86,0	5 500							

Models DV 6424 TD... and DV 6448 TD... are available in customer-specific, custom-developed variants only.

The data specified here are technically feasible benchmark values. The fans can be specially adapted to your application with signal outputs and control inputs.

For details of the technical possibilities, refer to the chapters on the sensor signal, alarm signal and control inputs beginning on page 108.

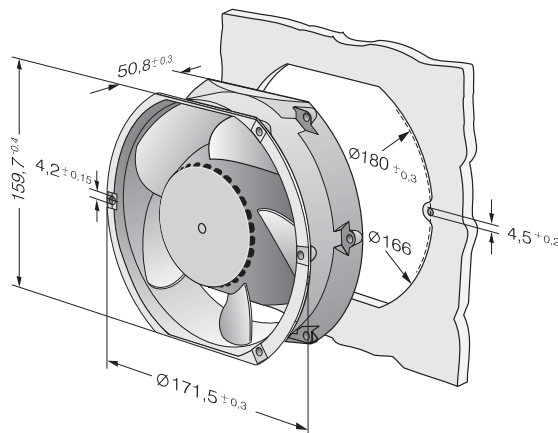
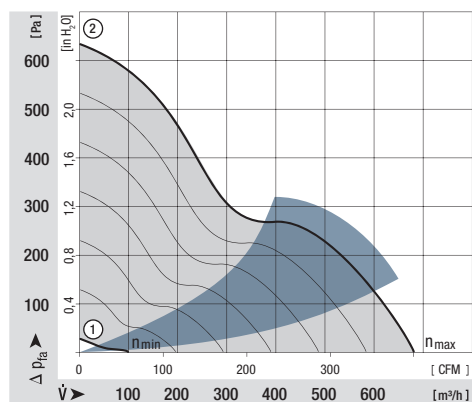

max. 1220 m³/h

DC axial fans

Series 2200 FTD 220 x 200 x 51 mm



Highlights:

- High- performance 200 mm fan with compact overall height.
- Low operating noise level at high back pressure.
- 3-phase fan drive high degree of running smoothness and high efficiency.
- Standard with speed signal and PWM (P) or 0-10VDC / PWM (O) speed control.

General characteristics:

- Material: aluminium housing, fibreglass-reinforced PA impeller; housing with grounding lug for screw M4 x 8.
- Electronic commutation fully integrated.
- Protected against reverse polarity and locking.
- Connection via single strands AWG 20, UL 1007 / AWG 22, UL 1061, bared and tin-plated.
- Air exhaust over struts. Direction of rotation counter-clockwise, seen on rotor.
- Mass: 1000 g.

Nominal data		Air flow	Air flow	Nominal voltage	Voltage range	Sound pressure level	Sound power level	Sinter sleeve bearings Ball bearings	Power input	Nominal speed	Temperature range	Service life L ₁₀ (40 °C) ebm-papst Standard	Service life L ₁₀ (τ max) ebm-papst Standard	Life expectancy L ₁₀ Δ (40 °C)	Curve	Specials
Type		m ³ /h	CFM	VDC	VDC	dB(A)	Bel(A)	■ / ■	Watts	RPM	°C	Hours	Hours	Hours		P. 110
NEW 2214 F/2TDH0		790	464,7	24	16...30	62	7,1	■	35,0	4250	-25...+75	90 000 / 42 500	180 000	180 000	1	/2
NEW 2214 F/2TDH10		940	552,9	24	16...36	66	7,4	■	35,0	5000	-25...+70	85 000 / 42 500	170 000	170 000	2	/2
NEW 2218 F/2TDH0		790	464,7	48	36...57	62	7,1	■	48,0	4250	-25...+75	90 000 / 42 500	180 000	180 000	1	/2
NEW 2218 F/2TDH10		940	552,9	48	36...72	66	7,4	■	48,0	5000	-25...+70	85 000 / 42 500	170 000	170 000	2	/2
NEW 2218 F/2TDH4P		1220	717,6	48	36...72	72	8,2	■	103,0	6500	-20...+65	70 000 / 40 000	140 000	140 000	3	/2

Speed control range from 1000 RPM up to maximum nominal speed. Stationary at 0 % PWM / 0 V,
Type O: stationary at sensor break; Type P: maximum speed at sensor break.

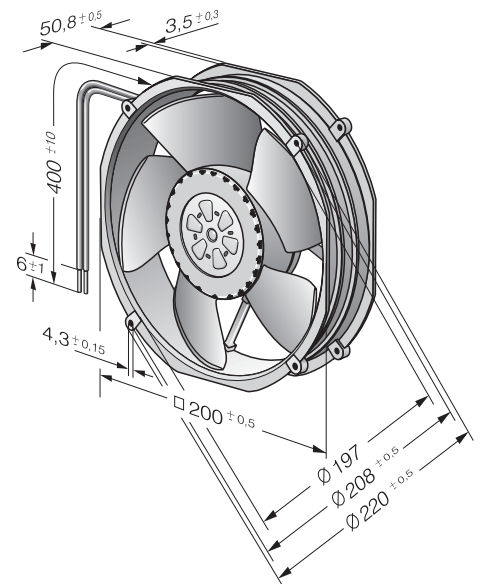
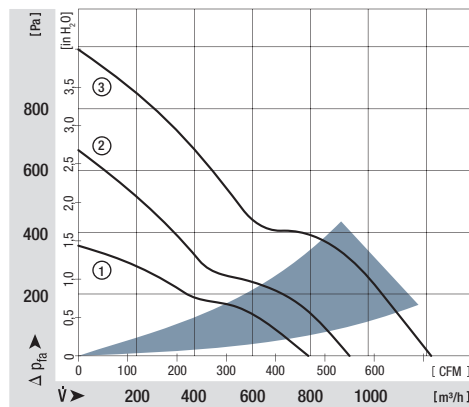

max. 1090 m³/h

DC axial fans

W1G 200 225 x 225 x 80 mm



- Material: Die-cast aluminium wall ring, 9 sheet steel blades. Blades and rotor coated in black.
- Protected against reverse polarity and locking.
- Direction of air flow: "V", exhaust over struts. Direction of rotation counter-clockwise, seen on rotor.
- Type of protection: IP 42. Insulation class: "B".
- Maintenance-free ball bearings.
- Control input 0-10 V DC / PWM and tach output.
- Electrical connection with terminal strip.
- Continuous operation (S1).
- Mass: 2.1 kg.

Nominal data		Air flow		Nominal voltage	Voltage range	Sound pressure level	Sound power level	Sinter sleeve bearings Ball bearings	Power input	Nominal speed	Temperature range	Service life L ₁₀ (40 °C) ebm-papst Standard	Service life L ₁₀ (T _{max}) ebm-papst Standard	Curve
Type	m ³ /h	CFM	VDC	VDC	dB(A)	Bel(A)	□ / ■	Watts	RPM	°C	Hours			
W1G 200-HH77-52	1090	641,6	24	16...28	60	—	■	55,0	2 950	-25...+60	57 000 / 42 000		1	
W1G 200-HH01-52	1090	641,6	48	36...57	60	—	■	55,0	2 950	-25...+60	57 000 / 42 000		1	

	n [RPM]	P ₁ [W]	Lp _A [dB(A)]
① ①	2300	73	63
① ②	2970	77	62
① ③	3100	80	63
① ④	2970	80	66
① ⑤	2950	55	60
① ⑥	2890	58	60
① ⑦	2800	61	61
① ⑧	2780	63	64
① ⑨	2270	27	55
① ⑩	2230	28	54
① ⑪	2170	29	54
① ⑫	2130	30	57

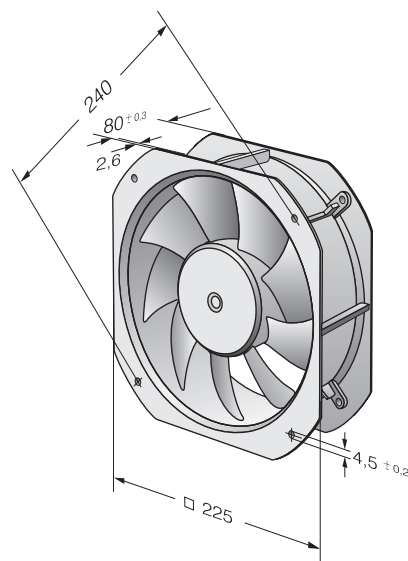
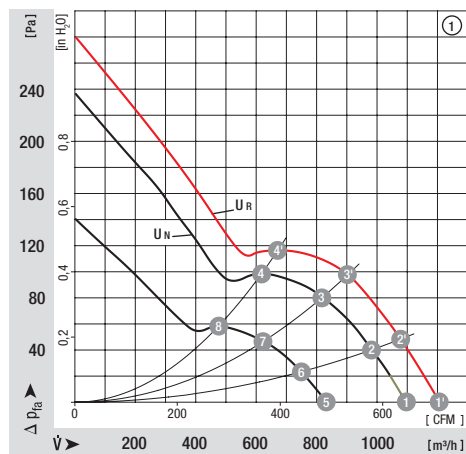

max. 1245 m³/h

DC diagonal module

K1G 200 225 x 225 x 80 mm



- Material: Housing made of fibreglass-reinforced PA6 plastic, seven blades made of fibre-glass-reinforced PA6 plastic. Rotor coated in black
- Protected against reverse polarity and locking.
- Direction of air flow "V". Direction of rotation CW, seen on rotor.
- Type of protection: IP 20 (... 02); IP 44 (... 04). Insulation class: "B".
- Maintenance-free ball bearings.
- Control input 0-10 VDC / PWM and tach output.
- Electrical connection via connection line AWG 20, 4x brass lead tips crimped.
- Continuous operation (S1).
- Mass: 1.7 kg.

Nominal data		Air flow	Air flow	Nominal voltage	Voltage range	Current draw	Sound power level	Sinter sleeve bearings Ball bearings	Power input	Nominal speed	Temperature range	Service life L ₁₀ (40 °C) ebm-papst Standard	Service life L ₁₀ (T _{max}) ebm-papst Standard	Curve
Type		m ³ /h	CFM	VDC	VDC	A	dB(A)	■ / ■	Watts	RPM	°C	Hours		
NEW	K1G 200-AD65-04	1020	600,3	24	16...28	4,7	76	■	95	3 400	-25...+60	67 000 / 33 000		1
NEW	K1G 200-AD31-02	1045	614,9	24	16...28	5,3	77	■	107	3 520	-25...+70	100 000 / 50 000		2
NEW	K1G 200-AD49-04	1095	644,4	48	36...57	3,4	77	■	120	3 650	-25...+60	80 000 / 32 000		3
NEW	K1G 200-AD37-02	1245	732,7	48	36...57	5,6	81	■	183	4 140	-25...+70	75 000 / 30 000		4

	n [RPM]	P ₁ [W]	I [A]	Lw _A [dB(A)]
① ①	3400	95	4,70	76
① ②	3410	116	5,61	74
① ③	3410	119	5,75	74
① ④	3410	117	5,62	76
② ①	3520	107	5,30	77
② ②	3520	127	6,24	75
② ③	3520	129	6,31	76
② ④	3520	126	6,18	76
③ ①	3650	120	3,40	77
③ ②	3650	141	3,90	75
③ ③	3650	145	3,99	76
③ ④	3650	141	3,88	78
④ ①	4140	183	5,60	81
④ ②	4090	212	6,46	79
④ ③	4060	213	6,52	79
④ ④	4110	211	6,43	80

Air performance measured as per: ISO 5801, Installation category A, without protection against accidental contact

Suction-side noise levels: Lw_A as per ISO 13347

The acoustic values given are only valid under the measurement conditions listed and may vary depending on the installation situation.

With any deviation to the standard setup, the specific values have to be checked and re-viewed once installed or fitted!

Cable assignment:

- Red = UN
- Yellow = 0-10 VDC
- White = Speed monitoring output
- Blue = GND

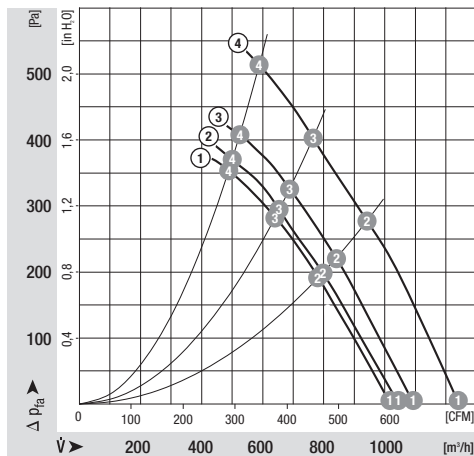
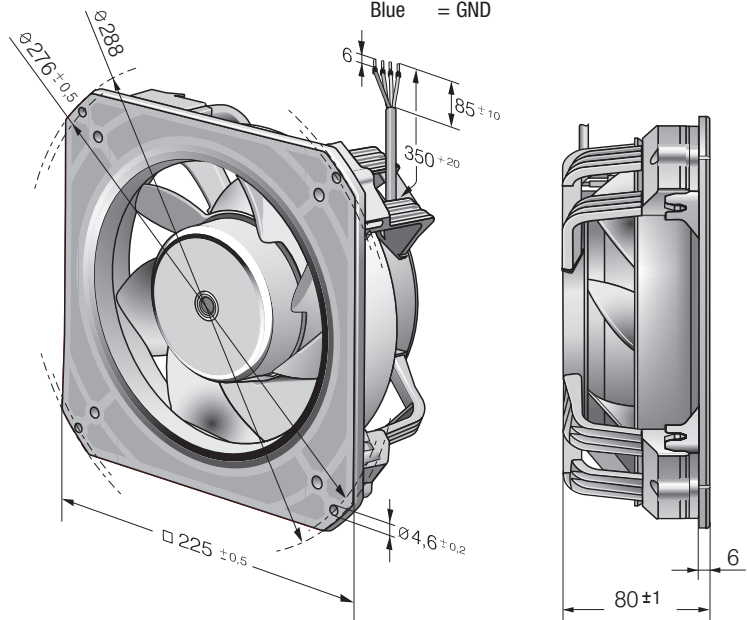

max. 1640 m³/h

DC diagonal module

K3G 200 225 x 225 x 89 mm



- Material: Housing made of fibreglass-reinforced PA6 plastic, seven blades made of fibre-glass-reinforced PA6 plastic. Rotor coated in black
- Protected against reverse polarity and locking.
- Direction of air flow "V". Direction of rotation CW, seen on rotor.
- Type of protection: IP 20 (... 02); IP 44 (... 04). Insulation class: "B".
- Maintenance-free ball bearings.
- Control input 0-10 VDC / PWM and tach output.
- Electrical connection via connection line AWG 16, 4x crimped core-end sleeves.
- Continuous operation (S1).
- Mass: 2.2 kg.

Nominal data		Air flow	Air flow	Nominal voltage	Voltage range	Current draw	Sound power level	Sinter sleeve bearings Ball bearings	Power input	Nominal speed	Temperature range	Service life L ₁₀ (40 °C) ebm-papst Standard	Service life L ₁₀ (T _{max}) ebm-papst Standard	Curve
Type		m ³ /h	CFM	VDC	VDC	A	dB(A)	□ / ■	Watts	RPM	°C	Hours		
NEW	K3G 200-BDA3-04	1215	716,0	24	16...28	7,7	81	■	185	4 060	-25...+60	55 000 / 31 000		1
NEW	K3G 200-BDA1-02	1215	716,0	24	16...28	7,7	81	■	185	4 060	-25...+65	60 000 / 32 000		1
NEW	K3G 200-BDA4-04	1550	911,0	48	36...57	7,1	86	■	339	5 140	-25...+60	52 000 / 32 000		2
NEW	K3G 200-BDA2-02	1640	965,0	48	36...57	8,7	87	■	418	5 480	-25...+60	40 000 / 22 000		3

	n [RPM]	P ₁ [W]	I [A]	Lw _A [dB(A)]
① ①	4060	185	7,70	81
① ②	4010	204	8,48	78
① ③	4010	209	8,70	78
① ④	4020	208	8,66	79
② ①	5140	339	7,10	86
② ②	5070	373	7,78	83
② ③	5060	385	8,01	83
② ④	5080	380	7,91	84
③ ①	5480	418	8,70	87
③ ②	5250	421	8,77	84
③ ③	5190	422	8,78	83
③ ④	5240	421	8,77	85

Air performance measured as per: ISO 5801, Installation category A, without protection against accidental contact

Suction-side noise levels: Lw_A as per ISO 13347

The acoustic values given are only valid under the measurement conditions listed and may vary depending on the installation situation.

With any deviation to the standard setup, the specific values have to be checked and re-viewed once installed or fitted!

Cable assignment:

- Red = UN
- Yellow = 0-10 VDC
- White = Speed monitoring output
- Blue = GND

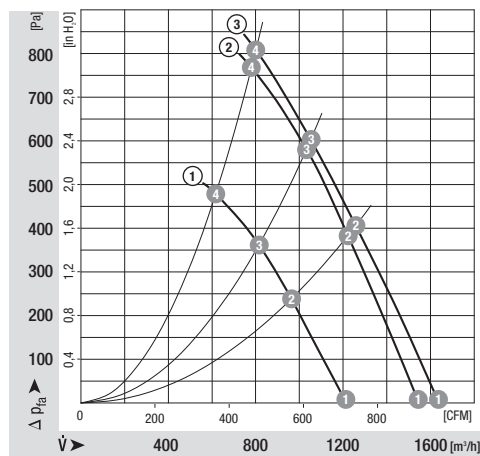
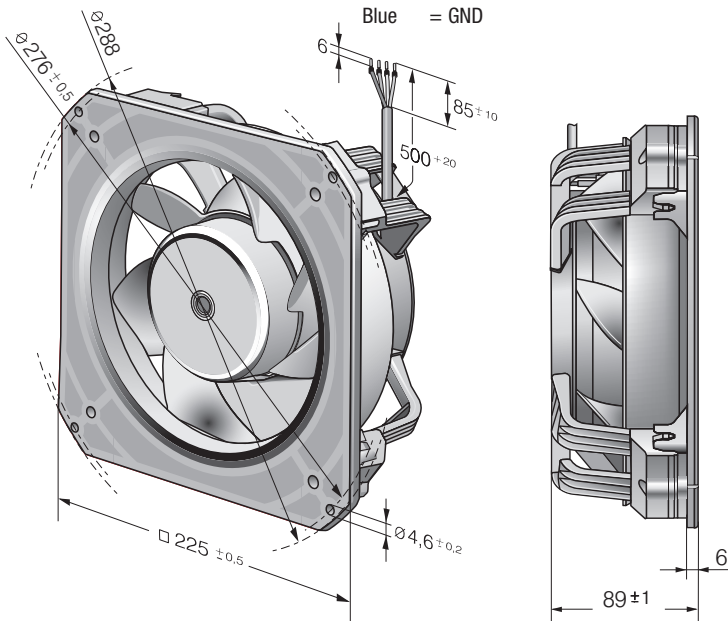

max. 1920 m³/h

DC axial fans

W1G 250 280 x 280 x 80 mm



- Material: Die-cast aluminium wall ring, 7 sheet steel blades. Blades and rotor coated in black.
- Protected against reverse polarity and locking.
- Direction of air flow: "V", exhaust over struts. Direction of rotation counter-clockwise, seen on rotor.
- Type of protection: IP 42. Insulation class: "B".
- Maintenance-free ball bearings.
- Control input 0-10 V DC / PWM and tach output.
- Electrical connection with terminal strip.
- Continuous operation (S1).
- Mass: 2.4 kg.

Nominal data	Air flow		Nominal voltage	Voltage range	Sound pressure level	Sound power level	Sinter sleeve bearings Ball bearings	Power input	Nominal speed	Temperature range	Service life L ₁₀ (40 °C) ebm-papst Standard	Service life L ₁₀ (T _{max}) ebm-papst Standard	Curve
	m ³ /h	CFM											
W1G 250-HH37-52	1920	1130,1	24	16...28	70	—	■	105,0	2 750	-25...+60	57 000 / 38 000		1
W1G 250-HH67-52	1920	1130,1	48	36...57	70	—	■	105,0	2 750	-25...+60	57 000 / 38 000		1

	n [RPM]	P ₁ [W]	Lp _A [dB(A)]
① ①	2920	129	71
① ②	2800	132	72
① ③	2680	135	71
① ④	2600	139	72
① ⑤	2750	105	70
① ⑥	2630	110	69
① ⑦	2520	111	69
① ⑧	2440	114	70
① ⑨	2610	73	66
① ⑩	2320	75	67
① ⑪	2230	78	67
① ⑫	2170	80	68

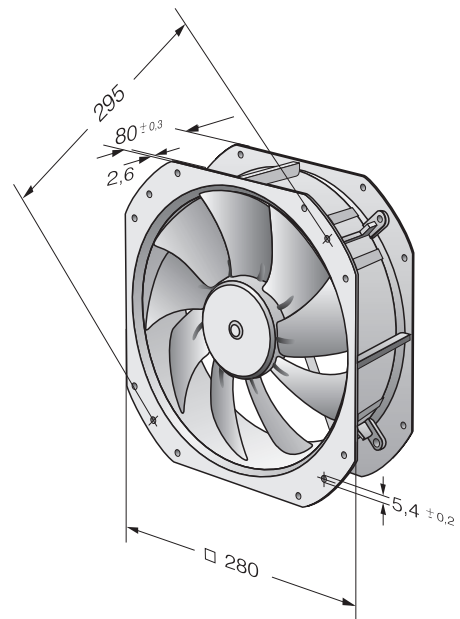
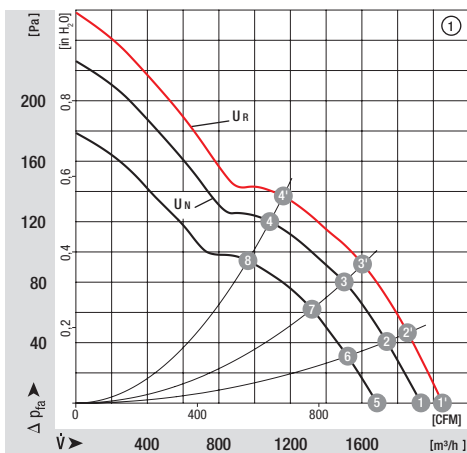

DC centrifugal fans

DC centrifugal fan overview	77
DC centrifugal fans	79
DC tangential fans	105



Technical information

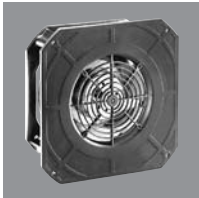

Product line

Our centrifugal product line includes fans for every application. Whether as free-running impellers with a diameter between 97 mm and 225 mm or as assemblies in a ready-to-install, compact housing with inlet nozzle with an edge length between 51 mm and 270 mm. Of course, all models feature high-efficiency, brushless motor technology.



Electronic protection against reverse polarity

ebm-papst DC fans have electronically commutated drives with electronic protection against reverse polarity. The electronics are conveniently located in the fan hub.

Product life expectancy

A distinctive feature of DC fan technology is the convincingly high product life expectancy. Thanks to the excellent efficiency of the brushless drives, the thermal load of the bearings is reduced, thus considerably increasing the life expectancy of the fans.

Protection class

DC fans with sleeve and ball bearings are powered by Class E insulated motors. All ebm-papst fans conform to the requirements of Protection Class IP 20. Fans conforming to IP 54 and special protection classes are also available.

Voltage range

Many of our DC fans can be operated on voltages that are up to 50% lower and 25% higher than their nominal voltage (see Voltage range in the technical tables). This enables the air performance to be adapted to the cooling requirements and allows the noise to be reduced, even if the fan does not have a control input.

Closed-loop speed control and monitoring

Closed-loop speed control and function monitoring are becoming increasingly important in many applications. ebm-papst offers many fans in the standard design with a control input and open collector speed signal.

S-Force centrifugal – RadiCal

The new S-Force centrifugal fans provide peak performance among fans of this type. With air flow capacity at over 1500 m³/h and a pressure build-up of up to 1000 pascals, the highest heat flows are manageable. In addition, the models are extremely efficient due to the multi-pole, electronically commutated drive motors and can be adapted individually to every application thanks to intelligent motor features. Some models use our new, highly efficient RadiCal impellers.

Centrifugal fans for DC operation

Overview of air performance

Dimensions	Series	Air flow	Air flow																Page								
			10	20	30	40	50	60	70	80	90	100	200	300	400	500	600	700		800	900	1000	2000	3000			
mm		m ³ /h																									
105 x 59 x 79	RV 40	18...24																									79
□ 51 x 15	RLF 35	9,6																									80
□ 76 x 27	RL 48	22...28																									81
97 x 93,5 x 33	RL 65	56...61																									82
□ 121 x 37	RL 90 N	40...55																									83
□ 127 x 25	RLF 100	64...80																									84
□ 135 x 38	RG 90 N	55																									85
□ 180 x 40	RG 125 N	60...137																									86
□ 220 x 56	RG 160 N	139...209																									87
□ 220 x 56	RG 160 NTD	59...370																									88
□ 225 x 85	RG 190 TD	630...930																									89
□ 270 x 99	RG 220 TD	1090...1280																									90
□ 270 x 119	RG 225 TD	1040...1210																									91
∅ 97 x 41	RET 97 TD	220																									92
∅ 104 x 25	REF 100	86...104																									93
∅ 101 x 52	RER 101	190																									94
∅ 120 x 54	RER 120 TD	320...390																									95
∅ 138 x 35	RER 125 N	74...166																									96
∅ 133 x 91	RER 133 TD	460...565																									97
∅ 165 x 51	RER 160 N	255																									98
∅ 165 x 51	RER 160 NTD	66...354																									99
∅ 175 x 55	REF 175 TD	800																									100
∅ 175 x 69	RER 175 TD	600...980																									101
∅ 190 x 69	RER 190 TD	650...970																									102
∅ 220 x 71	RER 220 TD	1090...1280																									103
∅ 225 x 99	RER 225 TD	1080...1600																									104
201...413 x 50 x 48	QG 030	75...155																									105



Centrifugal fans for DC operation

Overview of technically feasible designs

Centrifugal fans		V	R	U	Tr	Li	PM	A	HP	IP54	Sp	P.	
Series	mm	OPTIONAL										P.	
RV 40	105 x 59 x 79	yes ■	–	•	–	–	–	•	–	–	•	–	79
RLF 35	51 x 51 x 15	* ■	•	–	–	–	–	–	–	–	•	–	80
RL 48	76 x 76 x 27	yes ■	•	•	–	–	–	–	–	–	•	–	81
RL 65	97 x 93,5 x 33	* ■	•	•	•	•	•	•	•	–	•	–	82
RL 90 N	121 x 121 x 37	yes □/■	•	•	•	•	•	•	•	–	•	•	83
RLF 100	127 x 127 x 25	yes ■	•	•	•	•	•	•	•	–	•	•	84
RG 90 N	135 x 135 x 38	yes □/■	•	•	•	•	•	•	•	–	•	•	85
RG 125 N	180 x 180 x 40	yes ■	•	•	•	•	•	•	•	–	•	•	86
RG 160 N	220 x 220 x 56	yes ■	•	•	•	•	•	•	•	–	•	•	87
NEW RG 160 NTD	220 x 220 x 56	yes ■	•	•	•	•	•	•	•	–	•	•	88
NEW RG 190 TD	225 x 225 x 85	yes ■	•	•	•	•	•	•	•	–	•	•	89
NEW RG 220 TD	270 x 270 x 99	yes ■	•	•	•	•	•	•	•	–	•	•	90
NEW RG 225 TD	270 x 270 x 132	yes ■	•	•	•	•	•	•	•	–	•	•	91
NEW RET 97 TD	97 Ø x 41	* ■	•	•	•	•	•	•	•	–	•	–	92
REF 100	100 Ø x 25	yes ■	•	•	•	•	•	•	•	–	•	•	93
RER 101	101 Ø x 52	* ■	•	•	•	•	•	•	•	–	•	–	94
NEW RER 120 TD	120 Ø x 54	* ■	•	•	•	•	•	•	•	–	•	–	95
RER 125 N	138 Ø x 35	yes ■	•	•	•	•	•	•	•	–	•	–	96
NEW RER 133 TD	133 Ø x 91	* ■	•	•	•	•	•	•	•	–	•	–	97
RER 160 N	165 Ø x 51	yes ■	•	•	•	•	•	•	•	–	•	•	98
NEW RER 160 NTD	165 Ø x 51	yes ■	•	•	•	•	•	•	•	–	•	•	99
NEW REF 175 TD	175 Ø x 55	* ■	•	•	•	•	•	•	•	–	•	–	100
NEW RER 175 TD	175 Ø x 69	* ■	•	•	•	•	•	•	•	–	•	•	101
NEW RER 190 TD	190 Ø x 69	* ■	•	•	•	•	•	•	•	–	•	•	102
NEW RER 220 TD	220 Ø x 71	* ■	•	•	•	•	•	•	•	–	•	–	103
NEW RER 225 TD	225 Ø x 99	* ■	•	•	•	•	•	•	•	–	•	–	104
QG 030	201...413 x 50 x 48	yes ■	•	–	–	–	–	–	–	–	•	–	105

* approvals applied for
 – not yet available
 • available
 □ Sleeve Bearings
 ■ Ball Bearings

Please note that these special versions are not possible for all voltages and speeds, and not in all combinations. The special versions are designed for specific customers and projects. As a rule they are not available off the shelf and are tied to minimum volumes. Please consult your customer support representative about the feasibility of your special variant.

Optional special versions / Information pictograms (see page 20)

On the catalogue pages and in the overview on page 20, the pictograms shown provide information about the special designs that are technically feasible in the fan series. Please note that these special versions are not possible for all voltages and speeds, and not in all combinations.

The special versions are designed for specific customers and projects and are not usually available off the shelf.

max. 24 m³/h

DC centrifugal fans

Series RV 40 105 x 59 x 79 mm



Highlights:

- Pressure-optimised blower.
- Motor with very low structure-borne noise properties.
- Forward curved impeller.

General characteristics:

- Fibreglass-reinforced plastic scroll housing and impeller.
- Fully integrated electronic commutation.
- Protected against reverse polarity and locking.
- Direction of air flow: axial air intake, centrifugal air exhaust out of the outlet.
- Connection via single strands AWG 26, TR 64. Bared and tin-plated.
- Mass: 100 g.

Nominal data		Air flow	Air flow	Nominal voltage	Voltage range	Sound power level	Sinter sleeve bearings Ball bearings	Power input	Nominal speed	Temperature range	Service life L ₁₀ (40 °C) ebm-papst Standard	Service life L ₁₀ (T _{max}) ebm-papst Standard	Life expectancy L ₁₀ Δ (40 °C) see P. 15	Curve	Specials
Type		m ³ /h	CFM	VDC	VDC	Bel(A)	□ / ■	Watts	RPM	°C	Hours	Hours			
RV 40-18/12 L		18	10,6	12	9...16	4,0	■	2,0	3 900	-20...+70	70 000 / 35 000	110 000	1		
RV 40-18/12 H		24	14,1	12	9...16	5,0	■	4,5	4 800	-20...+70	50 000 / 25 000	80 000	2		

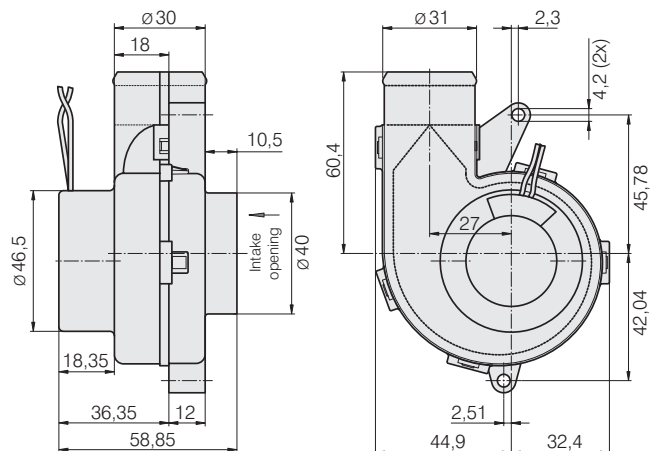
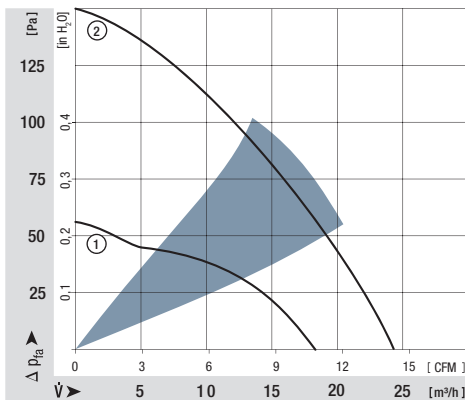

max. 9,6 m³/h

DC centrifugal fans

Series RLF 35 51 x 51 x 15 mm

Highlights:

- Noise-optimised air outlet in scroll housing.
- Very flat and powerful centrifugal fan.
- Forward curved impeller.

General characteristics:

- Fibreglass-reinforced plastic scroll housing and impeller.
- Fully integrated electronic commutation.
- Protected against reverse polarity and locking.
- Direction of air flow: axial air intake, centrifugal air exhaust out of the outlet.
- Connection via single strands AWG 26, TR 64. Bared and tin-plated.
- Mass: 40 g.



Nominal data	Air flow		Nominal voltage	Voltage range	Sound power level	Sinter sleeve bearings Ball bearings	Power input	Nominal speed	Temperature range	Service life L ₁₀ (40 °C) ebm-papst Standard	Service life L ₁₀ (T _{max}) ebm-papst Standard	Life expectancy L ₁₀ ^Δ (40 °C) see P. 15	Curve	Specials
	m ³ /h	CFM												
RLF 35-8/12 N	9,6	5,7	12	8...13,2	5,5	■	3,5	6 700	-20...+70	60 000 / 30 000	120 000	1		
RLF 35-8/14 N	9,6	5,7	24	14...28	5,5	■	4,3	6 700	-20...+70	60 000 / 30 000	120 000	1		

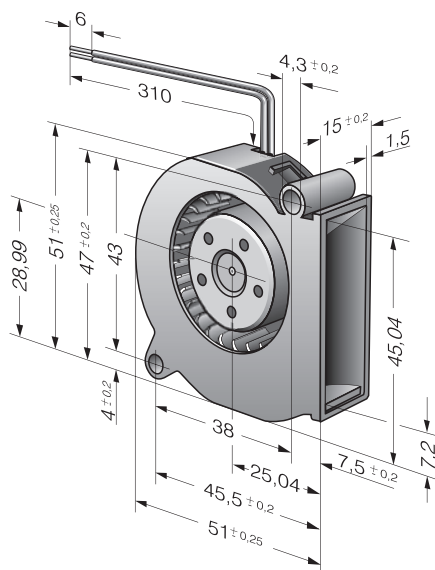
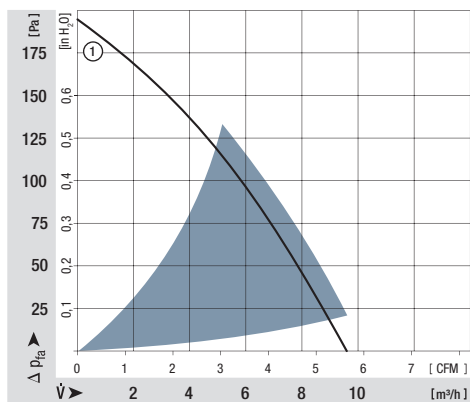

max. 28 m³/h

DC centrifugal fans

Series RL 48 76 x 76 x 27 mm



Highlights:

- Pressure-optimised blower.
- Noise-optimised air outlet in scroll housing.
- Forward curved impeller.

General characteristics:

- Fibreglass-reinforced plastic scroll housing and impeller.
- Fully integrated electronic commutation.
- Protected against reverse polarity and locking.
- Direction of air flow: axial air intake, centrifugal air exhaust out of the outlet.
- Connection via single strands AWG 26, TR 64. Bared and tin-plated.
- Mass: 75 g.

Nominal data		Air flow	Air flow	Nominal voltage	Voltage range	Sound power level	Sintec sleeve bearings Ball bearings	Power input	Nominal speed	Temperature range	Service life L ₁₀ (40 °C) ebm-papst Standard	Service life L ₁₀ (T _{max}) ebm-papst Standard	Life expectancy L ₁₀ Δ (40 °C) see P. 15	Curve	Specials
Type		m ³ /h	CFM	VDC	VDC	Bel(A)	■ / ■	Watts	RPM	°C	Hours	Hours	Hours	P. 110	
RL 48-19/12 ML		22	12,9	12	8...15	5,3	■	2,9	3 500	-20...+70	70 000 / 35 000	140 000	1		
RL 48-19/12		28	16,5	12	8...13,5	5,7	■	5,0	4 400	-20...+70	60 000 / 30 000	120 000	2	/2	
RL 48-19/14 ML		22	12,9	24	18...28	5,3	■	2,9	3 500	-20...+70	70 000 / 35 000	140 000	1		
RL 48-19/14		28	16,5	24	18...26,4	5,7	■	5,0	4 400	-20...+70	60 000 / 30 000	120 000	2	/2	

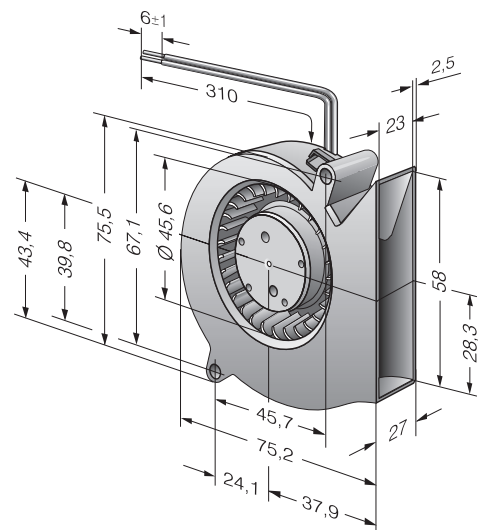
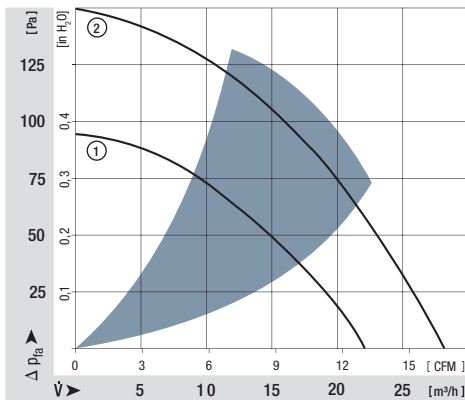

max. 61 m³/h

DC centrifugal fans

Series RL 65 97 x 93,5 x 33 mm



Highlights:

- Optional Vario-Pro: Highly adaptable software configuration of the fan enables a tailor-made solution to the specific requirements of your applications.
- Pressure-optimised blower. Noise-optimised air outlet in scroll housing.
- Forward curved impeller.
- Integrated snap-in fins for easy assembly.

General characteristics:

- Fibreglass-reinforced plastic scroll housing and impeller.
- Fully integrated electronic commutation.
- Protected against reverse polarity and locking.
- Direction of air flow: axial air intake, centrifugal air exhaust out of the outlet.
- Connection via single strands AWG 26, TR 64. Bared and tin-plated.
- Mass: 170 g.

Nominal data	Air flow		Nominal voltage	Voltage range	Sound power level	Sinter sleeve bearings Ball bearings	Power input	Nominal speed	Temperature range	Service life L ₁₀ (40 °C) ebm-papst Standard	Service life L ₁₀ (T _{max}) ebm-papst Standard	Life expectancy L ₁₀ ^Δ (40 °C) see P. 15	Curve	Specials
	m ³ /h	CFM												
RL 65-21/12	56	33,0	12	6,8...13,8	6,6	■	15,0	4 500	-20...+70	60 000 / 30 000	120 000	1	/2	
RL 65-21/12H	61	35,9	12	6,8...13,2	6,8	■	19,2	4 900	-20...+55	55 000 / 37 500	105 000	2		
RL 65-21/14	56	33,0	24	12...26,4	6,6	■	14,0	4 500	-20...+70	60 000 / 30 000	120 000	1		
RL 65-21/14H	61	35,9	24	12...26,4	6,8	■	18,0	4 900	-20...+60	55 000 / 35 000	105 000	2		

Snap-in fins for easy assembly

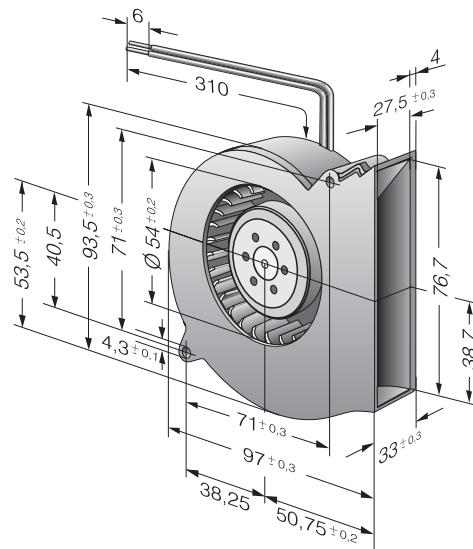
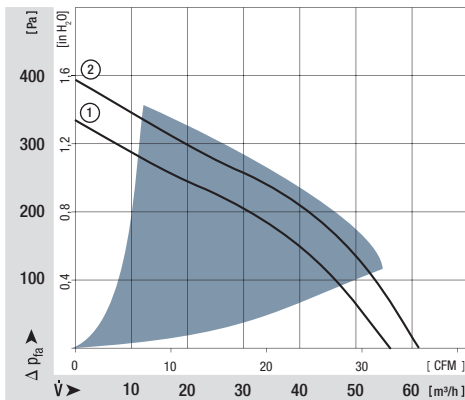
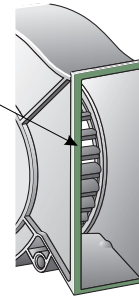

max. 55 m³/h

DC centrifugal fans

Series RL 90 N 121 x 121 x 37 mm



Highlights:

- Optional Vario-Pro: Highly adaptable software configuration of the fan enables a tailor-made solution to the specific requirements of your applications.
- Forward curved impeller.

General characteristics:

- Fibreglass-reinforced plastic scroll housing and impeller; Housing base of steel plate.
- Fully integrated electronic commutation.
- Protected against reverse polarity and locking.
- Direction of air flow: axial air intake, centrifugal air exhaust out of the outlet.
- Connection via single strands AWG 22, TR 64. Bared and tin-plated.
- Mass: 420 g.

Nominal data		Air flow	Air flow	Nominal voltage	Voltage range	Sound power level	Sintec sleeve bearings Ball bearings	Power input	Nominal speed	Temperature range	Service life L ₁₀ (40 °C) ebm-papst Standard	Service life L ₁₀ (T _{max}) ebm-papst Standard	Life expectancy L ₁₀ ^Δ (40 °C) see P. 15	Curve	Specials
Type		m ³ /h	CFM	VDC	VDC	Bel(A)	□ / ■	Watts	RPM	°C	Hours	Hours		P. 110	
RL 90-18/12 N		40	23,5	12	7...15	5,8	■	5,5	2 500	-30...+75	62 500 / 27 500	112 500	1	/2	
RL 90-18/14 NG		40	23,5	24	12...28	5,8	□	5,0	2 500	-10...+75	62 500 / 27 500	112 500	1		
RL 90-18/14 N		40	23,5	24	12...28	5,8	■	5,0	2 500	-30...+75	62 500 / 27 500	112 500	1	/2	
RL 90-18/18 NH		55	32,4	48	40...53	6,9	■	15,0	3 500	-30...+55	32 500 / 22 500	62 500	2		

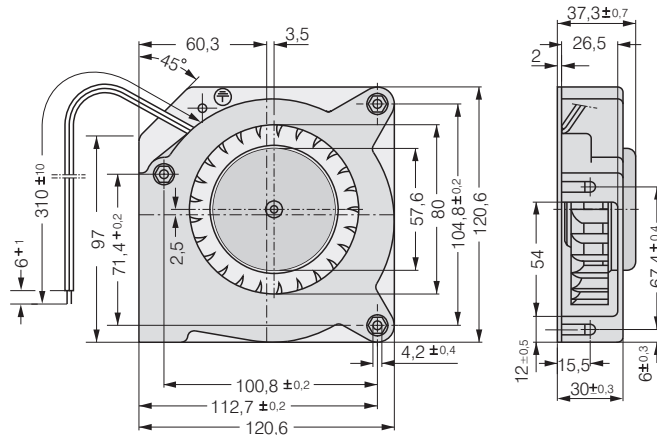
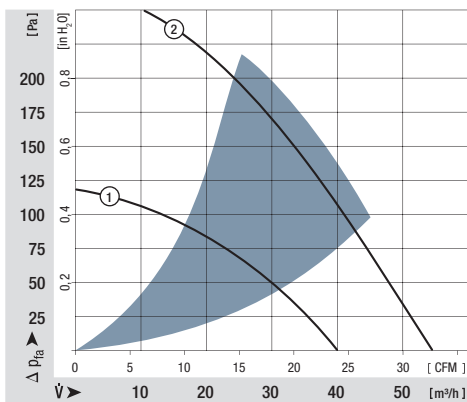

Screw clip M4 or 8-32UNC. Screw-in depth max. 12.5 min. 9.0

max. 80 m³/h

DC centrifugal fans

Series RLF 100 127 x 127 x 25 mm

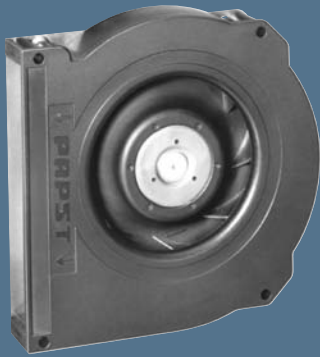

Highlights:

- Very flat and powerful centrifugal fan. Pressure-optimised blower.
- Optional Vario-Pro: Highly adaptable software configuration of the fan enables a tailor-made solution to the specific requirements of your applications.
- Some models available as standard with PWM control input and speed signal.
- Backward curved impeller.

General characteristics:

- Fibreglass-reinforced plastic scroll housing and impeller. Housing base of galvanised steel plate.
- Fully integrated electronic commutation. Protected against reverse polarity and locking.
- Direction of air flow: axial air intake, centrifugal air exhaust out of the outlet.
- Connection via single strands AWG 22, TR 64. Bared and tin-plated.
- Mass: 320 g.

Nominal data	Air flow		Nominal voltage	Voltage range	Sound power level	Sinter sleeve bearings Ball bearings	Power input	Nominal speed	Temperature range	Service life L ₁₀ (40 °C) ebm-papst Standard	Service life L ₁₀ (T _{max}) ebm-papst Standard	Life expectancy L ₁₀ Δ (40 °C) see P. 15	Curve	Specials
	m ³ /h	CFM												
RLF 100-11/12	64	37,7	12	8...15	6,4	■	8,0	5 100	-20...+75	80 000 / 30 000		150 000	1	/2
RLF 100-11/14	64	37,7	24	16...30	6,4	■	8,0	5 100	-20...+75	80 000 / 30 000		150 000	1	/19
RLF 100-11/18	64	37,7	48	36...60	6,4	■	8,6	5 100	-20...+75	80 000 / 30 000		150 000	1	
High speed models with Open Collector Tacho and PWM speed control.														
RLF 100-11/12/2HP-200	80	47,1	12	10...13,2	7,5	■	18,6	6 400	-20...+60	72 500 / 45 000		112 500	2	/2
RLF 100-11/18/2HP-182	80	47,1	48	43...53	7,5	■	17,0	6 400	-20...+70	72 500 / 35 000		112 500	2	/2

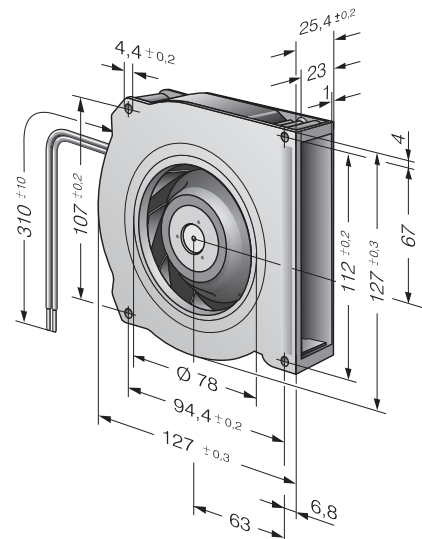
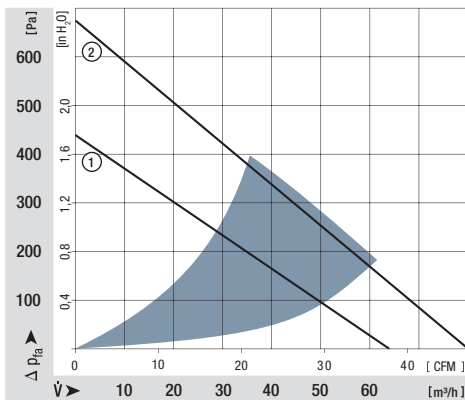

max. 55 m³/h

DC centrifugal fans

Series RG 90 N 135 x 135 x 38 mm

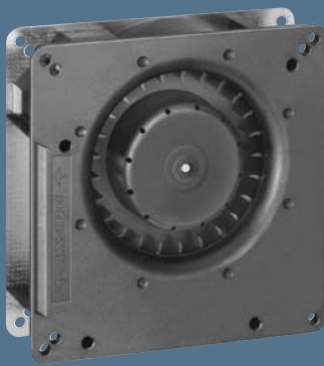

Highlights:

- Optional Vario-Pro: Highly adaptable software configuration of the fan enables a tailor-made solution to the specific requirements of your applications.
- Backward curved impeller.

General characteristics:

- Fibreglass-reinforced plastic scroll housing and impeller; Housing base of steel plate.
- Fully integrated electronic commutation.
- Protected against reverse polarity and locking.
- Direction of air flow: axial air intake, centrifugal air exhaust out of the outlet.
- Connection via single strands AWG 22, TR 64. Bared and tin-plated.
- 48 V Model: Flat plug 6.3 x 0.8 mm for protective earth.
- Mass: 440 g.

Nominal data	Air flow		Nominal voltage	Voltage range	Sound power level	Sinter sleeve bearings Ball bearings		Power input	Nominal speed	Temperature range	Service life L ₁₀ (40 °C) ebm-papst Standard	Service life L ₁₀ (T _{max}) ebm-papst Standard	Life expectancy L ₁₀ Δ (40 °C) see P. 15	Curve	Specials
	m ³ /h	CFM				VDC	VDC								
RG 90-18/12 N	55	32,4	12	7...15	5,5	■	6,0	2 200	-30...+75	62 500 / 27 500	112 500	1			
RG 90-18/14 NG	55	32,4	24	12...28	5,5	□	5,5	2 200	-10...+75	62 500 / 27 500	112 500	1			
RG 90-18/14 N	55	32,4	24	12...28	5,5	■	5,5	2 200	-30...+75	62 500 / 27 500	112 500	1			
RG 90-18/18 N	55	32,4	48	36...56	5,5	■	5,5	2 200	-30...+75	62 500 / 27 500	112 500	1			

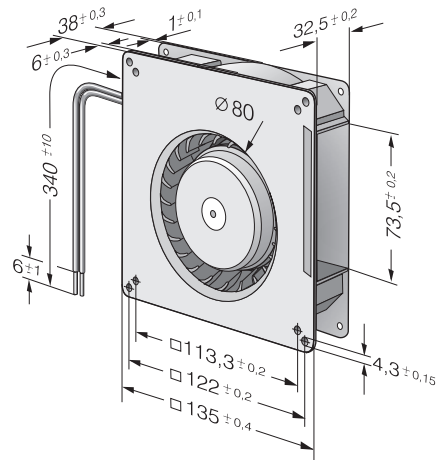
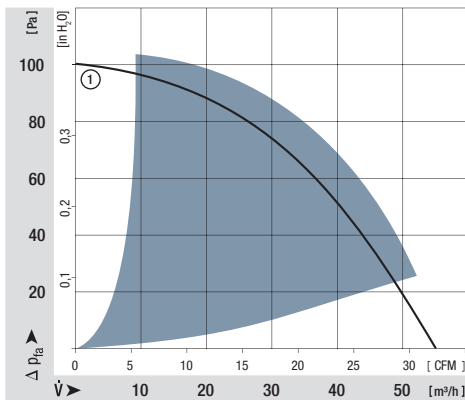

max. 137 m³/h

DC centrifugal fans

Series RG 125 N 180 x 180 x 40 mm

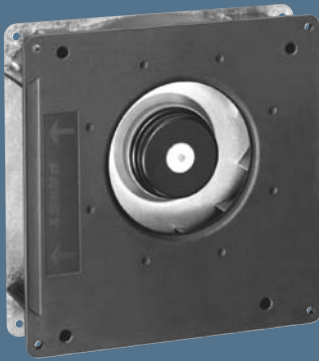

Highlights:

- Optional Vario-Pro: Highly adaptable software configuration of the fan enables a tailor-made solution to the specific requirements of your applications.
- Backward curved impeller.

General characteristics:

- Fibreglass-reinforced plastic scroll housing and impeller; Housing base of steel plate.
- Fully integrated electronic commutation.
- Protected against reverse polarity and locking.
- Direction of air flow: axial air intake, centrifugal air exhaust out of the outlet.
- Connection via single strands AWG 22, TR 64. Bared and tin-plated.
- 48 V Model: Flat plug 6.3 x 0.8 mm for protective earth.
- Mass: 730 g.

Nominal data	Air flow		Nominal voltage	Voltage range	Sound power level	Sinter sleeve bearings Ball bearings	Power input	Nominal speed	Temperature range	Service life L ₁₀ (40 °C) ebm-papst Standard	Service life L ₁₀ (T _{max}) ebm-papst Standard	Life expectancy L ₁₀ ^Δ (40 °C) see P. 15	Curve	Specials
	m ³ /h	CFM												
RG 125-19/12 NM	60,0	35,3	12	7...15	4,8	■	2,0	1 750	-30...+75	70 000 / 30 000	135 000	1		
RG 125-19/12 N	87,5	51,5	12	7...15	5,8	■	5,0	2 550	-30...+75	62 500 / 27 500	125 000	2	/2/12	
RG 125-19/14 NM	60,0	35,3	24	12...28	4,8	■	2,0	1 750	-30...+75	70 000 / 30 000	135 000	1		
RG 125-19/14 N	87,5	51,5	24	12...28	5,8	■	5,0	2 550	-30...+75	62 500 / 27 500	125 000	2	/2	
RG 125-19/18 N	87,5	51,5	48	36...56	5,8	■	5,0	2 550	-30...+75	62 500 / 27 500	125 000	2		
RG 125-19/18 NH	137	80,6	48	36...56	7,0	■	19,0	4 000	-20...+70	55 000 / 27 500	110 000	3		

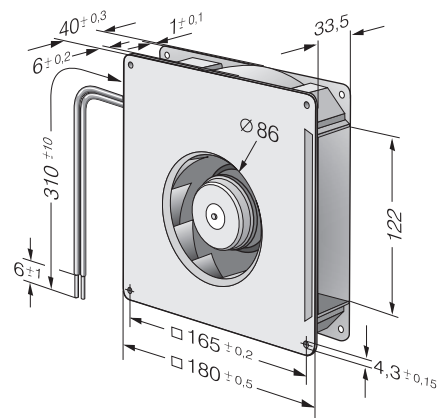
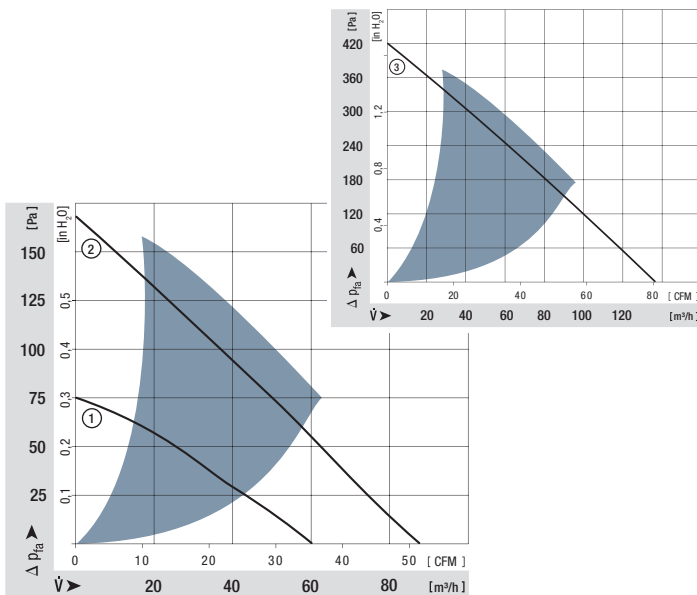

max. 209 m³/h

DC centrifugal fans

Series RG 160 N 220 x 220 x 56 mm

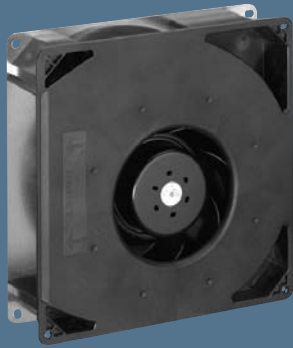

Highlights:

- Optional Vario-Pro: Highly adaptable software configuration of the fan enables a tailor-made solution to the specific requirements of your applications.
- Backward curved impeller.

General characteristics:

- Fibreglass-reinforced plastic scroll housing and impeller; Housing base of steel plate.
- Fully integrated electronic commutation.
- Protected against reverse polarity and locking.
- Direction of air flow: axial air intake, centrifugal air exhaust out of the outlet.
- Connection via single strands AWG 22, TR 64. Bared and tin-plated.
- 48 V Model: Flat plug 6.3 x 0.8 mm for protective earth.
- Mass: 1.4 kg.

Nominal data		Air flow	Air flow	Nominal voltage	Voltage range	Sound power level	Sinter sleeve bearings Ball bearings	Power input	Nominal speed	Temperature range	Service life L ₁₀ (40 °C) ebm-papst Standard	Service life L ₁₀ (T _{max}) ebm-papst Standard	Life expectancy L ₁₀ Δ (40 °C) see P. 15	Curve	Specials
Type		m ³ /h	CFM	VDC	VDC	Bel(A)	■ / ■	Watts	RPM	°C	Hours	Hours			P. 112
RG 160-28/12 NM		139	81,1	12	7...14	5,6	■	7,5	1 900	-20...+70	80 000 / 40 000	160 000	1		
RG 160-28/12 N		209	123,0	12	7,5...14	6,6	■	21,0	2 850	-20...+70	70 000 / 35 000	140 000	2	/12	
RG 160-28/14 NM		139	81,1	24	12...28	5,6	■	7,0	1 900	-20...+70	80 000 / 40 000	120 000	1		
RG 160-28/14 N		209	123,0	24	12...28	6,6	■	20,0	2 850	-20...+70	70 000 / 35 000	120 000	2		
RG 160-28/18 N		209	123,0	48	28...60	6,6	■	20,0	2 850	-20...+70	70 000 / 35 000	120 000	2	/12	

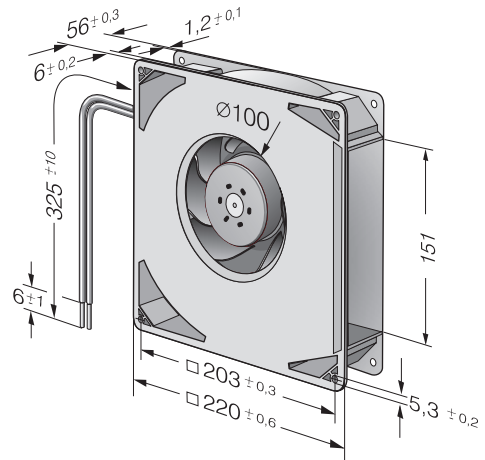
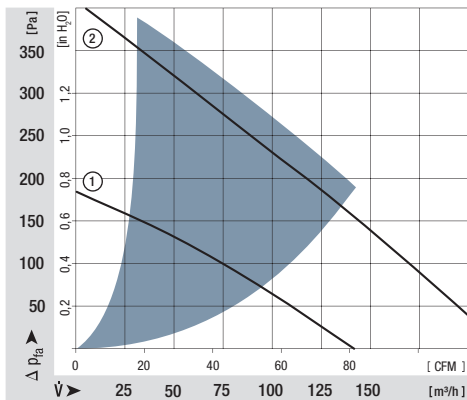

max. 444 m³/h

DC centrifugal fans

Series RG 160 NTD 220 x 220 x 56 mm

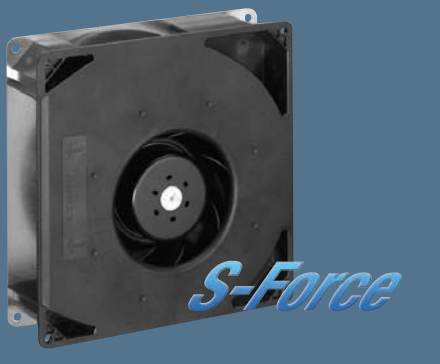

Highlights:

- Control inputs, alarm and speed signals available on request.
- 3-phase fan drive with high degree of running smoothness.
- Very high pressure build-up.
- Backward curved impeller.

General characteristics:

- Fibreglass-reinforced plastic scroll housing and impeller; Housing base of sheet steel.
- Fully integrated electronic commutation.
- Direction of air flow: axial air intake, centrifugal air exhaust out of the outlet.
- Connection via single strands AWG 22, TR 64. Bared and tin-plated.
- 48 V Model: Flat plug 6.3 x 0.8 mm for protective earth.
- Mass: 1.4 kg.

Nominal data		Air flow	Air flow	Nominal voltage	Voltage range	Sound power level	Sinter sleeve bearings Ball bearings	Power input	Nominal speed	Temperature range	Service life L ₁₀ (40 °C) ebm-papst Standard	Service life L ₁₀ (T _{max}) ebm-papst Standard	Life expectancy L ₁₀ Δ (40 °C) see P. 15	Curve	Specials
Type		m ³ /h	CFM	VDC	VDC	Bel(A)	□ / ■	Watts	RPM	°C	Hours	Hours	Hours	P.	
min. max.	RG 160-28/14 NTD...	59	16,4	24	16...28	—	■	2,0	800	-20...+60	55 000 / 27 500	110 000	1	1	
		308	85,6			7,5	64,0	4 200	2						
	RG 160-28/14 NTD	308	85,6	24	16...28	7,5	■	64,0	4 200	-20...+60	55 000 / 35 000	110 000	2	2	
	RG 160-28/14 NTDH	370	217,8	24	16...28	7,8	■	101,0	5 000	-20...+60	50 000 / 32 500	102 500	3	3	
min. max.	RG 160-28/18 NTD...	59	16,4	48	38...57	—	■	2,0	800	-20...+70	55 000 / 27 500	110 000	1	1	
		308	85,6			7,5	59,0	4 200	2						
NEW	RG 160-28/18/ 2NTDHP*	444	261,2	48	36...60	8,5	■	159	6 000	-20...+65	40 000 / 22 500	80 000	4	4	

Models RG 160-28/14 NTD... and RG 160-28/18 NTD... are available in customer-specific, custom-developed variants only. The data specified here are technically feasible benchmark values. The fans can be specially adapted to your application with signal outputs and control inputs.

*The specific service life is valid when an external capacitor is wired between the plus and minus strands. Please note the wiring suggestion.

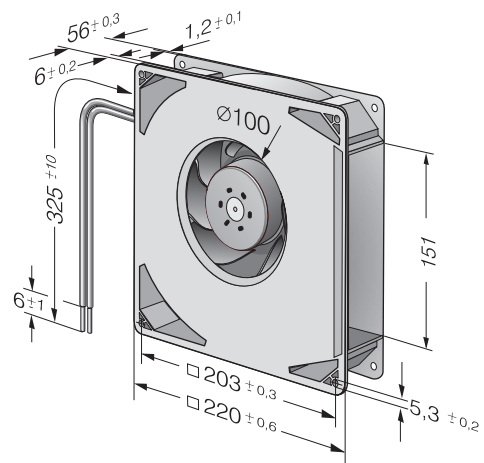
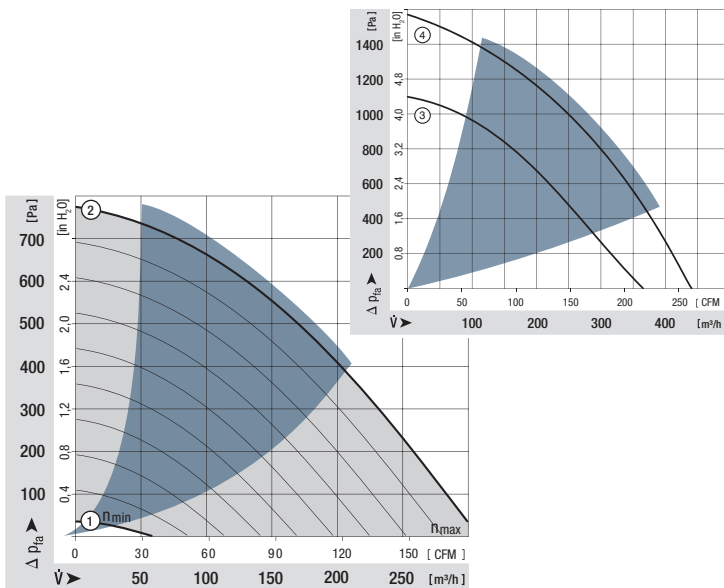

max. 930 m³/h

DC centrifugal fans

Series RG 190 TD 225 x 225 x 85 mm

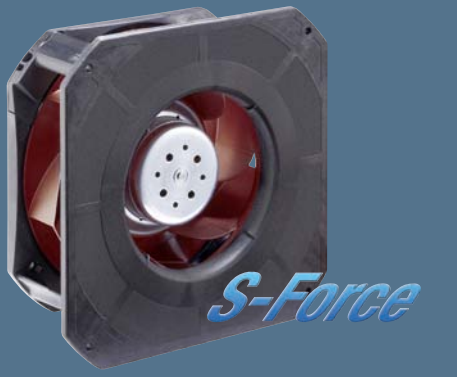

Highlights:

- 3-phase fan drive with high degree of running smoothness. Very high pressure build-up.
- Backward-curved RadiCal impeller with high efficiency.
- Standard models available with multifunctional control input for analogue, PWM and speed sign.
- Compact design with integrated mounting plate and optimised inlet nozzle.

General characteristics:

- Housing and impeller of fibreglass-reinforced plastic.
- Fully integrated electronic commutation.
- Direction of rotation: CW seen on rotor.
- Direction of air flow: axial air intake, centrifugal air exhaust out of the outlet.
- Connection via single strands AWG 18, 20 or AWG 22, TR 64, speed signal and control input AWG 22, bared and tin-plated.
- Mass: 1210 g.

Nominal data		Air flow	Air flow	Nominal voltage	Voltage range	Sound power level	Sinter sleeve bearings Ball bearings	Power input	Nominal speed	Temperature range	Service life L ₁₀ (40 °C) ebm-papst Standard	Service life L ₁₀ (T _{max}) ebm-papst Standard	Life expectancy L ₁₀ Δ (40 °C) see P. 15	Curve	Specials
Type		m ³ /h	CFM	VDC	VDC	Bel(A)	■ / ■	Watts	RPM	°C	Hours	Hours			
NEW	RG 190-39/14/2 TDML0	630	370,6	24	16...30	7,6	■	54	3 000	-20...+60	55 000 / 35 000	110 000	1		
NEW	RG 190-39/14/2 TDM0	820	482,4	24	16...36	7,9	■	100	3 900	-20...+65	52 500 / 30 000	105 000	2		
NEW	RG 190-39/18/2 TDML0	630	370,6	48	36...57	7,6	■	52	3 000	-20...+65	55 000 / 35 000	110 000	1		
NEW	RG 190-39/18/2 TDM0	820	482,4	48	36...72	7,9	■	100	3 900	-20...+65	52 500 / 30 000	105 000	2		
NEW	RG 190-39/18/2 TDO	930	547,1	48	36...72	8,3	■	135	4 400	-20...+65	40 000 / 25 000	80 000	3		

Speed control range from 800 rpm at 7 % PWM up to nominal speed at > 90 % PWM. Standstill at 0 % PWM, standstill if control cable is interrupted.



For suitable guard grilles, see page 176.

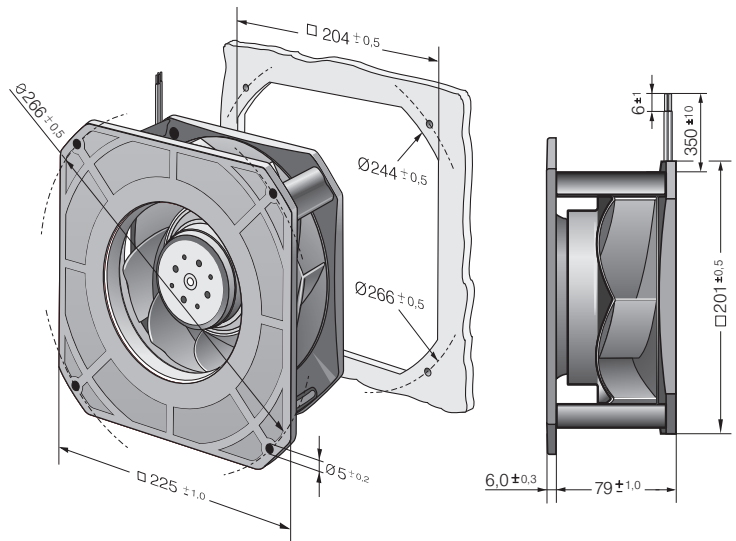
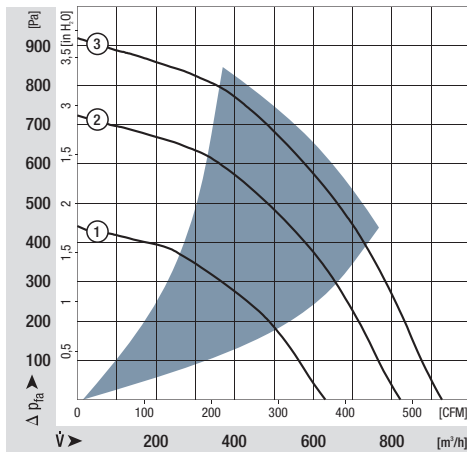

max. 1280 m³/h

DC centrifugal fans

Series RG 220 TD 270 x 270 x 99 mm

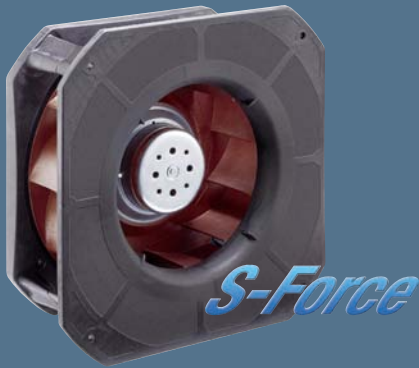

Highlights:

- 3-phase fan drive with high degree of running smoothness. Very high pressure build-up.
- Backward-curved impeller.
- Standard models available with multifunctional control input for analogue, PWM and speed signal.
- Compact design with integrated mounting plate and optimised inlet nozzle.

General characteristics:

- Housing and impeller of fibreglass-reinforced plastic.
- Fully integrated electronic commutation.
- Direction of rotation: CW seen on rotor.
- Direction of air flow: axial air intake, centrifugal air exhaust out of the outlet.
- Connection via single strands AWG 18, 20 or AWG 22, TR 64, speed signal and control input AWG 22, bared and tin-plated.
- Mass: 1870 g.

Nominal data		Air flow	Air flow	Nominal voltage	Voltage range	Sound power level	Sinter sleeve bearings Ball bearings	Power input	Nominal speed	Temperature range	Service life L ₁₀ (40 °C) ebm-papst Standard	Service life L ₁₀ (T _{max}) ebm-papst Standard	Life expectancy L ₁₀ ^Δ (40 °C) see P. 15	Curve	Specials
Type		m ³ /h	CFM	VDC	VDC	Bel(A)	■ / ■	Watts	RPM	°C	Hours	Hours	Hours		
NEW	RG 220-44/14/2TDMO	1090	641,2	24	16...36	7,7	■	82	3 000	-20...+55	75 000 / 52 500	150 000	150 000	1	
NEW	RG 220-44/18/2TDMO	1090	641,2	48	36...72	7,7	■	80	3 000	-20...+55	75 000 / 52 500	150 000	150 000	1	
NEW	RG 220-44/18/2TDO	1280	752,9	48	36...72	8,0	■	140	3 500	-20...+55	55 000 / 40 000	110 000	110 000	2	

Speed control range from 800 rpm at 7 % PWM up to nominal speed at > 90 % PWM. Standstill at 0 % PWM, standstill if control cable is interrupted.

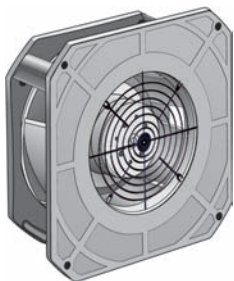

For suitable guard grilles, see page 176.

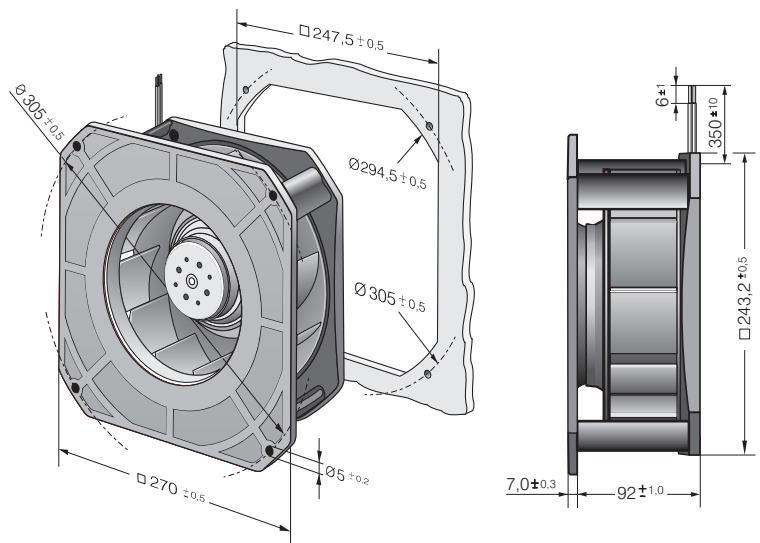
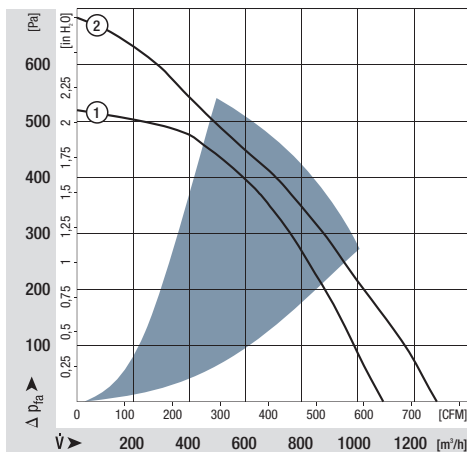

max. 1210 m³/h

DC centrifugal fans

Series RG 225 TD 270 x 270 x 119 mm

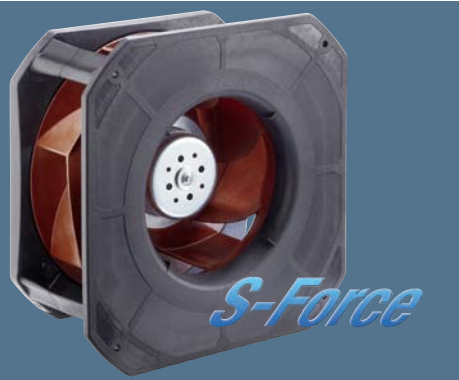

Highlights:

- 3-phase fan drive with high degree of running smoothness. Very high pressure build-up.
- Backward-curved RadiCal impeller with high efficiency.
- Standard models available with multifunctional control input for analogue, PWM and speed sign.
- Compact design with integrated mounting plate and optimised inlet nozzle.

General characteristics:

- Housing and impeller of fibreglass-reinforced plastic.
- Fully integrated electronic commutation.
- Direction of rotation: CW seen on rotor.
- Direction of air flow: axial air intake, centrifugal air exhaust out of the outlet.
- Connection via single strands AWG 18, 20 or AWG 22, TR 64, speed signal and control input AWG 22, bared and tin-plated.
- Mass: 1750 g.

Nominal data		Air flow	Air flow	Nominal voltage	Voltage range	Sound power level	Sinter sleeve bearings Ball bearings	Power input	Nominal speed	Temperature range	Service life L ₁₀ (40 °C) ebm-papst Standard	Service life L ₁₀ (T _{max}) ebm-papst Standard	Life expectancy L ₁₀ ^Δ (40 °C) see P. 15	Curve	Specials
Type		m ³ /h	CFM	VDC	VDC	Bel(A)	■ / ■	Watts	RPM	°C	Hours	Hours	Hours		
NEW	RG 225-55/14/2TDML0	1040	611,8	24	16...36	7,3	■	65	2 400	-20...+55	72 500 / 52 500	145 000	145 000	1	
NEW	RG 225-55/18/2TDML0	1040	611,8	48	36...72	7,3	■	65	2 400	-20...+55	72 500 / 52 500	145 000	145 000	1	
NEW	RG 225-55/18/2TDM0	1210	711,8	48	36...72	7,9	■	116	2 800	-20...+55	55 000 / 40 000	110 000	110 000	2	

Speed control range from 800 rpm at 7 % PWM up to nominal speed at > 90 % PWM. Standstill at 0 % PWM, standstill if control cable is interrupted.

The specific service life is valid when an external capacitor is wired between the plus and minus strands. Please note the wiring suggestion.

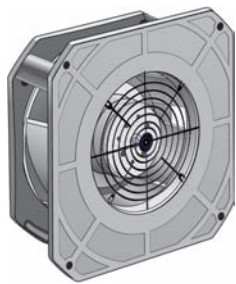

For suitable guard grilles, see page 176.

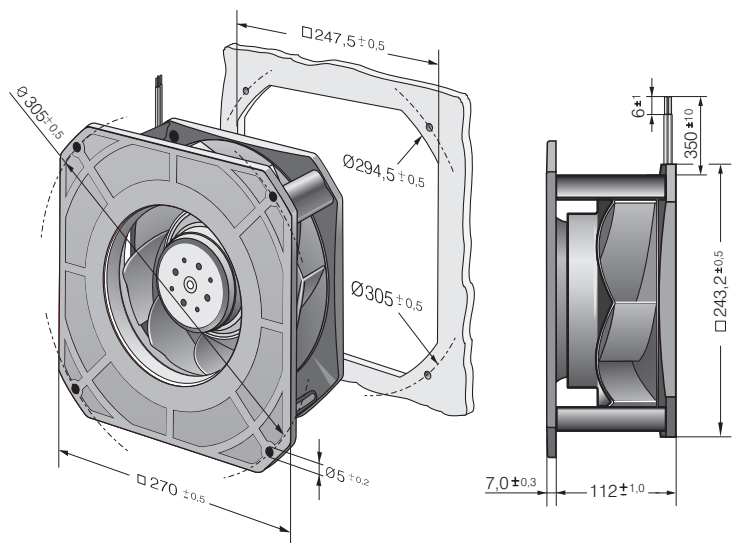
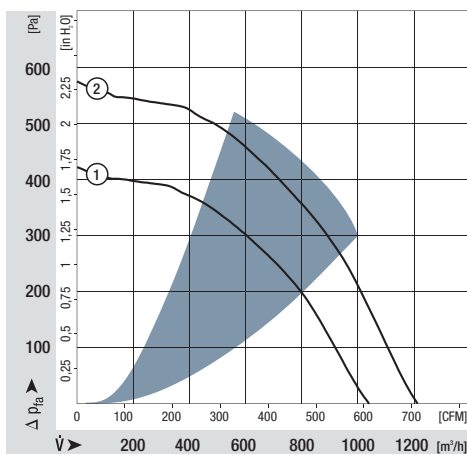

max. 220 m³/h

DC centrifugal fans

Series RET 97 TD 97 Ø x 41 mm



Highlights:

- 3-phase fan drive with high degree of running smoothness.
- Very high pressure build-up.
- Forward curved impeller.
- Available as standard with PWM control input and speed signal. Additional inputs and outputs on request.

General characteristics:

- Impeller of galvanised steel plate.
- Fully integrated electronic commutation.
- Direction of rotation: CW seen on rotor.
- Direction of air flow: axial air intake, centrifugal air exhaust out of the outlet.
- Connection via single strands AWG 22, TR 64. Bared and tin-plated.
- Mass: 430 g.

Nominal data		Air flow	Air flow	Nominal voltage	Voltage range	Sound power level	Sinter sleeve bearings Ball bearings	Power input	Nominal speed	Temperature range	Service life L ₁₀ (40 °C) ebm-papst Standard	Service life L ₁₀ (T _{max}) ebm-papst Standard	Life expectancy L ₁₀ Δ (40 °C) see P. 15	Curve	Specials
Type		m ³ /h	CFM	VDC	VDC	Bel(A)	■ / ■	Watts	RPM	°C	Hours	Hours			
NEW	RET 97-25/14/2TDP*	220	129	24	16...36	8,1	■	72	6 000	-20...+60	80 000 / 50 000	160 000	1		
NEW	RET 97-25/18/2TDP	220	129	48	36...60	8,1	■	72	6 000	-20...+60	80 000 / 50 000	160 000	1		

* Preliminary

Speed control range from 800 rpm at 7 % PWM up to nominal speed at > 90 % PWM. Standstill at 0 % PWM, maximum speed at sensor break.

To attain the specified service life, an external capacitor must be wired between the plus and minus strands. Please note the wiring suggestion on page.

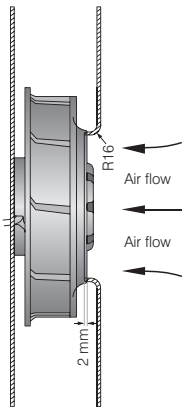

The air flow and noise level of fans without external housing depends on the installation conditions. The stated air flow and noise levels have been measured under the following conditions:
Centrifugal fan mounted on a base plate 116 x 116 mm.
Cover plate 116 x 116 mm with an air inlet of Ø 80 mm, concentric to the impeller.

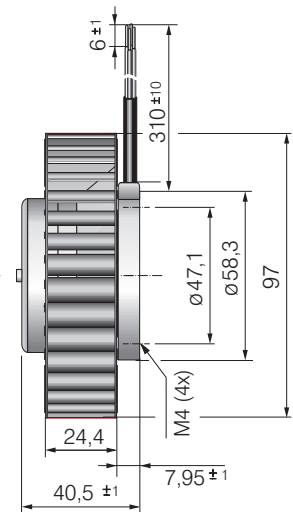
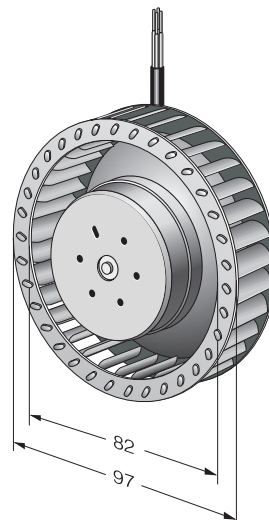
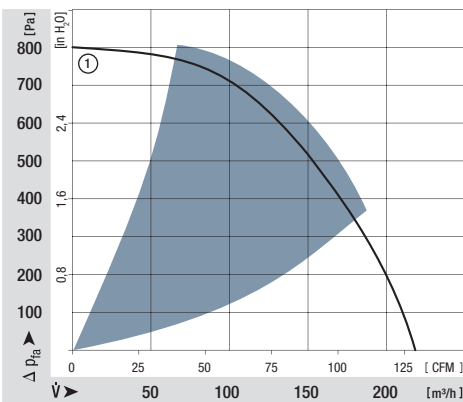

max. 104 m³/h

DC centrifugal fans

Series REF 100 104 Ø x 25 mm



Highlights:

- Pressure-optimised blower.
- Very flat and powerful centrifugal fan.
- Optional Vario-Pro: Highly adaptable software configuration of the fan enables a tailor-made solution to the specific requirements of your applications.
- Backward curved impeller.

General characteristics:

- Fibreglass-reinforced plastic scroll housing and impeller.
- Fully integrated electronic commutation.
- Protected against reverse polarity and locking.
- Direction of air flow radial, direction of rotation clockwise, seen on rotor.
- Connection via single strands AWG 22, TR 64. Bared and tin-plated.
- Mass: 160 g

Nominal data		Air flow	Air flow	Nominal voltage	Voltage range	Sound power level	Sinter sleeve bearings Ball bearings	Power input	Nominal speed	Temperature range	Service life L ₁₀ (40 °C) ebm-papst Standard	Service life L ₁₀ (T _{max}) ebm-papst Standard	Life expectancy L ₁₀ Δ (40 °C) see P. 15	Curve	Specials
Type	m ³ /h	CFM	VDC	VDC	Bel(A)	■ / ■	Watts	RPM	°C	Hours	Hours	Hours	P. 110		
REF 100-11/12	86	50,6	12	8...15	6,3	■	7,5	5 400	-20...+75	80 000 / 30 000	135 000	1	/2		
REF 100-11/14	86	50,6	24	16...30	6,3	■	7,5	5 400	-20...+75	80 000 / 30 000	135 000	1	/2		
REF 100-11/18	86	50,6	48	36...60	6,3	■	7,5	5 400	-20...+75	80 000 / 30 000	135 000	1	/2		
REF 100-11/18 H	104	61,2	48	36...56	6,9	■	14,8	6 700	-20...+70	67 500 / 30 000	120 000	2			

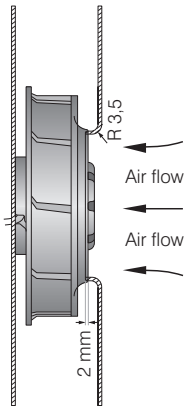

The air flow and noise level of fans without external housing depends on the installation conditions. The stated air flow and noise levels have been measured under the following conditions:
Centrifugal fan mounted on a base plate 127 x 127 mm.
Cover plate 127 x 127 mm with an air inlet of Ø 70 mm, concentric to the impeller.

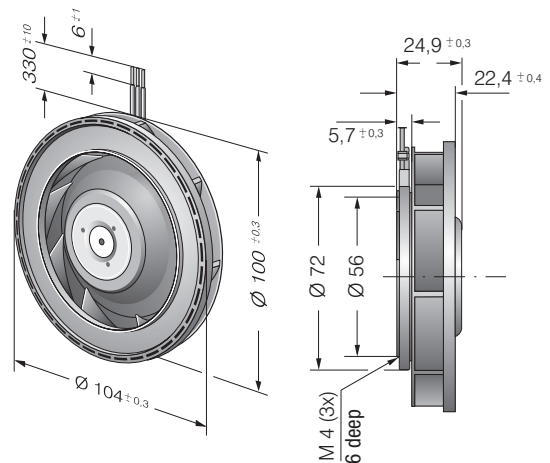
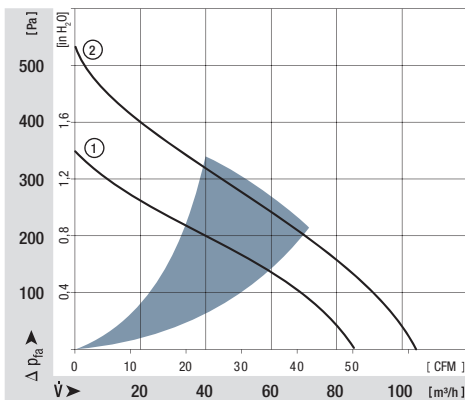

max. 190 m³/h

DC centrifugal fans

Series RER 101 101 Ø x 52 mm



Highlights:

- Optional Vario-Pro: Highly adaptable software configuration of the fan enables a tailor-made solution to the specific requirements of your applications.
- Backward curved impeller.

General characteristics:

- Fibreglass-reinforced plastic scroll housing and impeller.
- Fully integrated electronic commutation.
- Protected against reverse polarity and locking.
- Direction of air flow radial, direction of rotation clockwise, seen on rotor.
- Connection via single strands AWG 22, TR 64. Bared and tin-plated.
- Mass: 305 g.

Nominal data	Air flow		Nominal voltage	Voltage range	Sound power level	Sinter sleeve bearings Ball bearings	Power input	Nominal speed	Temperature range	Service life L ₁₀ (40 °C) ebm-papst Standard	Service life L ₁₀ (T _{max}) ebm-papst Standard	Life expectancy L ₁₀ ^Δ (40 °C) see P. 15	Curve	Specials
	m ³ /h	CFM												
RER 101-36/12NHH	190	111,8	12	9..13,6	7,2	■	20,5	5 900	-20...+70	60 000 / 30 000		120 000	1	
RER 101-36/14NHH	190	111,8	24	18..27,2	7,2	■	20,0	5 900	-20...+70	60 000 / 30 000		120 000	1	
RER 101-36/18NHH	190	111,8	48	43...52	7,2	■	19,0	5 900	-20...+70	60 000 / 30 000		120 000	1	/19

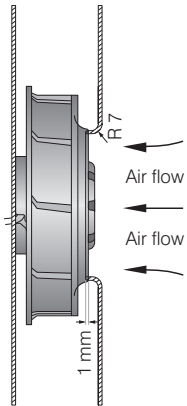

The air flow and noise level of fans without external housing depends on the installation conditions. The stated air flow and noise levels have been measured under the following conditions:
Centrifugal fan mounted on a base plate 148 x 148 mm.
Cover plate 148 x 148 mm with an air inlet of Ø 66 mm, concentric to the impeller.

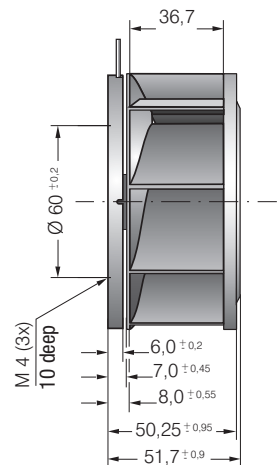
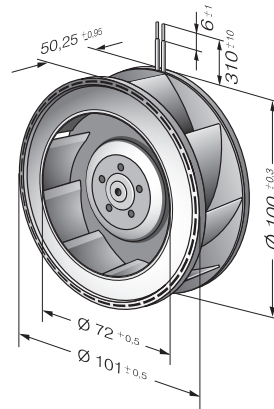
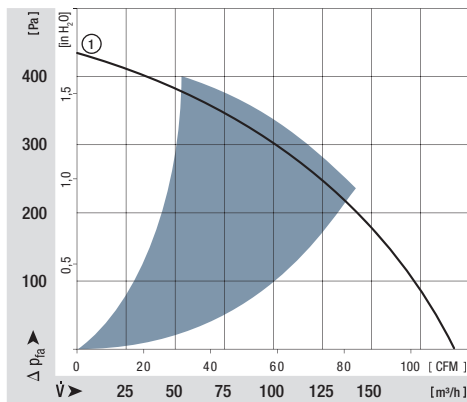

max. 390 m³/h

DC centrifugal fans

Series RER 120 TD 120 Ø x 54 mm



Highlights:

- 3-phase fan drive with high degree of running smoothness.
- Very high pressure build-up.
- Backward curved impeller.
- Available as standard with PWM control input and speed signal. Additional inputs and outputs on request.

General characteristics:

- Impeller of fibreglass-reinforced plastic.
- Fully integrated electronic commutation.
- Direction of rotation: CW seen on rotor.
- Direction of air flow: axial air intake, centrifugal air exhaust out of the outlet.
- Connection via single strands AWG 22, TR 64. Bared and tin-plated.
- Mass: 430 g.

Nominal data		Air flow	Air flow	Nominal voltage	Voltage range	Sound power level	Sinter sleeve bearings Ball bearings	Power input	Nominal speed	Temperature range	Service life L ₁₀ (40 °C) ebm-papst Standard	Service life L ₁₀ (T _{max}) ebm-papst Standard	Life expectancy L ₁₀ Δ (40 °C) see P. 15	Curve	Specials
Type		m ³ /h	CFM	VDC	VDC	Bel(A)	■ / ■	Watts	RPM	°C	Hours	Hours			
NEW	RER 120-26/14/2 TDMP*	320	188,2	24	16...32	tbd	■	51	5 200	-20...+60	60 000 / 37 500	120 000	1		
NEW	RER 120-26/14/2 TDP	377	221,9	24	16...32	8,2	■	78	6 100	-20...+60	55 000 / 35 000	110 000	2		
NEW	RER 120-26/18/2 TDMP*	320	188,2	48	36...60	tbd	■	51	5 200	-20...+60	57 500 / 35 000	115 000	1		
NEW	RER 120-26/18/2 TDP	390	229,5	48	36...60	8,3	■	92	6 300	-20...+60	50 000 / 30 000	100 000	3		

*Preliminary

Speed control range from 800 rpm at 7 % PWM up to nominal speed at > 90 % PWM, max. speed if control cable is interrupted.

The specific service life is valid when an external capacitor is wired between the plus and minus strands. Please note the wiring suggestion.

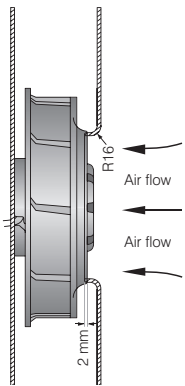

The air flow and noise level of fans without external housing depends on the installation conditions. The stated air flow and noise levels have been measured under the following conditions:
Centrifugal fan mounted on a base plate 140 x 140 mm.
Cover plate 140 x 140 mm with an air inlet of Ø 96 mm, concentric to the impeller.

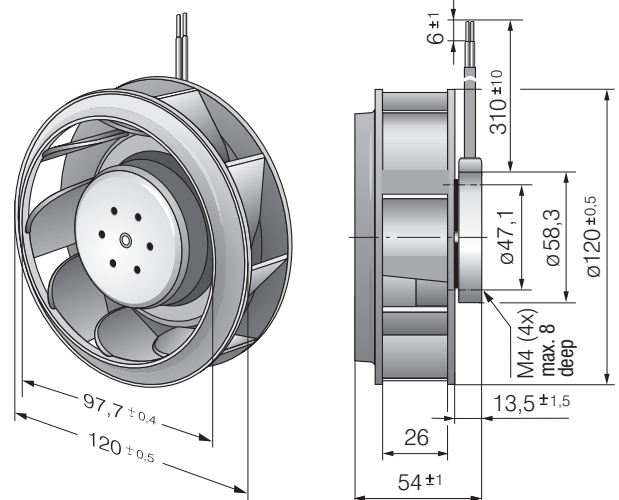
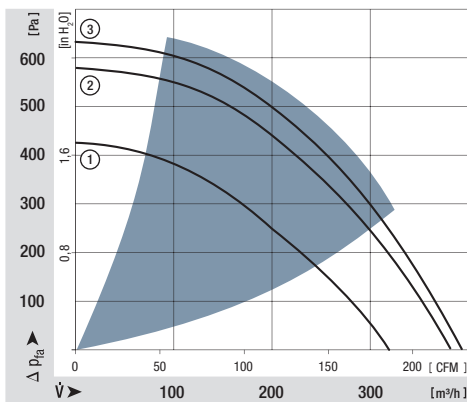

max. 166 m³/h

DC centrifugal fans

Series RER 125 N 138 Ø x 35 mm



Highlights:

- Optional Vario-Pro: Highly adaptable software configuration of the fan enables a tailor-made solution to the specific requirements of your applications.
- Backward curved impeller.

General characteristics:

- Fibreglass-reinforced plastic scroll housing and impeller.
- Fully integrated electronic commutation.
- Protected against reverse polarity and locking.
- Direction of air flow radial, direction of rotation clockwise, seen on rotor.
- Connection via single strands AWG 22, TR 64. Bared and tin-plated.
- Mass: 320 g.

Nominal data	Air flow		Nominal voltage	Voltage range	Sound power level	Sinter sleeve bearings Ball bearings	Power input	Nominal speed	Temperature range	Service life L ₁₀ (40 °C) ebm-papst Standard	Service life L ₁₀ (τ _{max}) ebm-papst Standard	Life expectancy L ₁₀ Δ (40 °C) see P. 15	Curve	Specials
	m ³ /h	CFM												
RER 125-19/12 N	110	64,7	12	7...15	5,7	■	4,5	2 650	-30...+75	62 500 / 27 500	125 000	1	/12	
RER 125-19/14 N	110	64,7	24	12...28	5,7	■	4,5	2 650	-30...+75	62 500 / 27 500	125 000	1		
RER 125-19/14 NH	166	97,7	24	12...28	7,0	■	13,0	4 000	-20...+70	55 000 / 27 500	110 000	2		
RER 125-19/18 N	110	64,7	48	36...56	5,7	■	5,0	2 650	-30...+75	62 500 / 27 500	125 000	1		

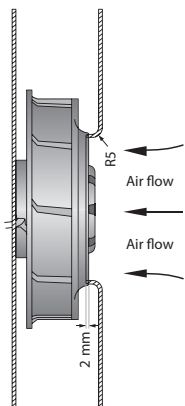

The air flow and noise level of fans without external housing depends on the installation conditions. The stated air flow and noise levels have been measured under the following conditions:
Centrifugal fan mounted on a base plate 220 x 220 mm.
Cover plate 220 x 220 mm with an air inlet of Ø 86 mm, concentric to the impeller.

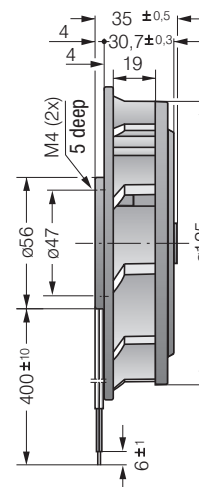
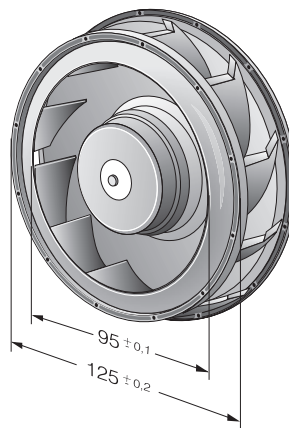
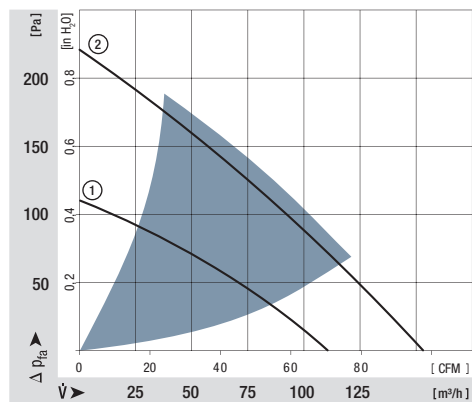

max. 565 m³/h

DC centrifugal fans

Series RER 133 TD 133 Ø x 91 mm



Highlights:

- 3-phase fan drive with high degree of running smoothness.
- Very high pressure build-up.
- Backward curved impeller.
- Available as standard with PWM control input and speed signal. Additional inputs and outputs on request.

General characteristics:

- Impeller of fibreglass-reinforced plastic.
- Fully integrated electronic commutation.
- Direction of rotation: CW seen on rotor.
- Direction of air flow: axial air intake, centrifugal air exhaust out of the outlet.
- Connection via single strands AWG 22, TR 64. Bared and tin-plated.
- Mass: 890 g.

Nominal data		Air flow	Air flow	Nominal voltage	Voltage range	Sound power level	Sinter sleeve bearings Ball bearings	Power input	Nominal speed	Temperature range	Service life L ₁₀ (40 °C) ebm-papst Standard	Service life L ₁₀ (T _{max}) ebm-papst Standard	Life expectancy L ₁₀ Δ (40 °C) see P. 15	Curve	Specials
Type		m ³ /h	CFM	VDC	VDC	Bel(A)	■ / ■	Watts	RPM	°C	Hours	Hours			
NEW	RER 133-41/14/2 TDMP	460	270,6	24	16...30	tbd	■	53	5 000	-20...+65	72 500 / 40 000	145 000	1		
NEW	RER 133-41/14/2 TDP*	565	332,4	24	16...36	tbd	■	90	6 000	-20...+65	70 000 / 37 500	140 000	2		
NEW	RER 133-41/18/2 TDMP*	460	270,6	48	36...57	tbd	■	50	5 000	-20...+65	72 500 / 40 000	145 000	1		
NEW	RER 133-41/18/2 TDP	565	332,4	48	36...72	8,2	■	87	6 000	-20...+65	70 000 / 37 500	140 000	2		

*Preliminary

Speed control range from 800 rpm at 7 % PWM up to nominal speed at > 90 % PWM. Standstill at 0 % PWM, max. speed if control cable is interrupted.

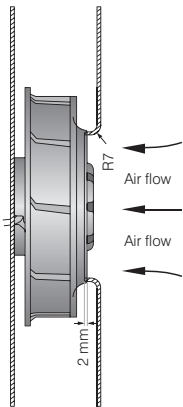

The air flow and noise level of fans without external housing depends on the installation conditions. The stated air flow and noise levels have been measured under the following conditions:
Centrifugal fan mounted on a base plate 140 x 140 mm.
Cover plate 140 x 140 mm with an air inlet of Ø 87 mm, concentric to the impeller.

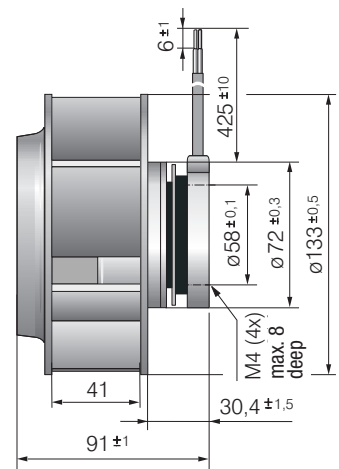
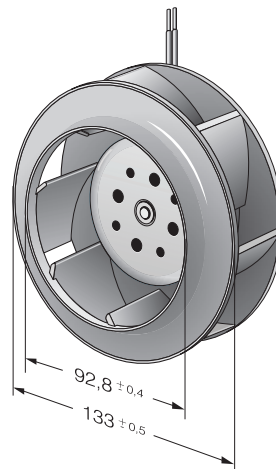
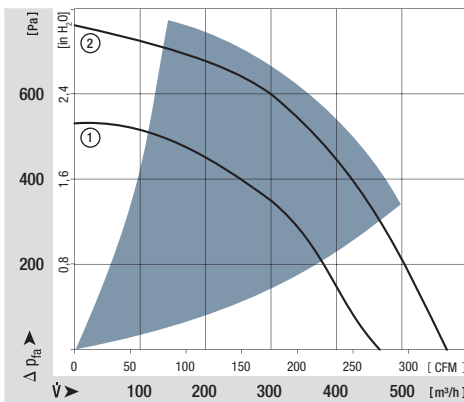

max. 255 m³/h

DC centrifugal fans

Series RER 160 N 165 Ø x 51 mm



Highlights:

- Optional Vario-Pro: Highly adaptable software configuration of the fan enables a tailor-made solution to the specific requirements of your applications.
- Backward curved impeller.

General characteristics:

- Fibreglass-reinforced plastic scroll housing and impeller.
- Fully integrated electronic commutation.
- Protected against reverse polarity and locking.
- Direction of air flow radial, direction of rotation clockwise, seen on rotor.
- Connection via single strands AWG 22, TR 64. Bared and tin-plated.
- Mass: 590 g.

Nominal data	Air flow		Nominal voltage	Voltage range	Sound power level	Sinter sleeve bearings Ball bearings	Power input	Nominal speed	Temperature range	Service life L ₁₀ (40 °C) ebm-papst Standard	Service life L ₁₀ (T _{max}) ebm-papst Standard	Life expectancy L ₁₀ ^Δ (40 °C) see P. 15	Curve	Specials
	m ³ /h	CFM												
RER 160-28/12 N	255	150,1	12	7...14	6,4	■	19,0	3 000	-20...+70	75 000 / 35 000		140 000	1	/12
RER 160-28/14 N	255	150,1	24	12...28	6,4	■	19,0	3 000	-20...+70	75 000 / 35 000		140 000	1	
RER 160-28/18 N	255	150,1	48	28...60	6,4	■	19,0	3 000	-20...+70	75 000 / 35 000		140 000	1	/12

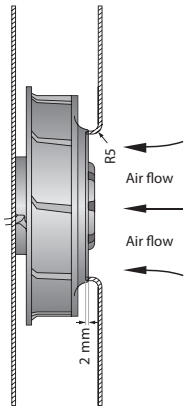

The air flow and noise level of fans without external housing depends on the installation conditions. The stated air flow and noise levels have been measured under the following conditions:
Centrifugal fan mounted on a base plate 260 x 260 mm.
Cover plate 260 x 260 mm with an air inlet of Ø 100 mm, concentric to the impeller.

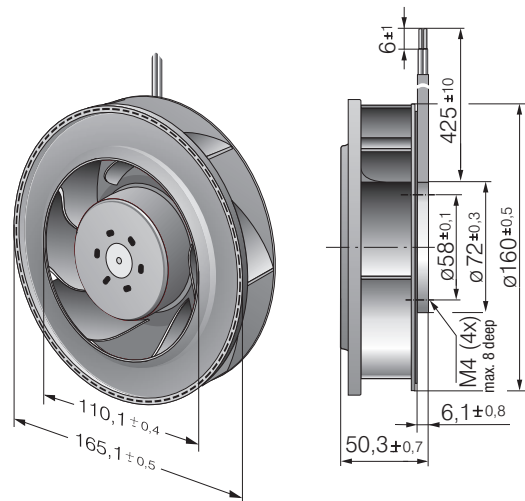
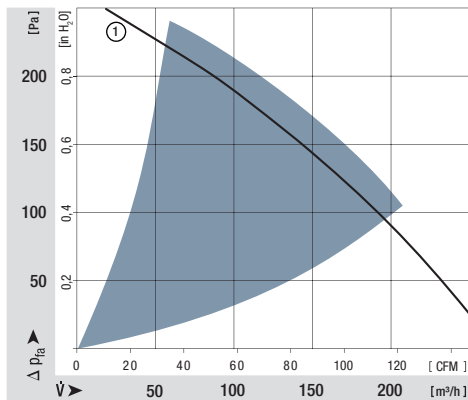

max. 505 m³/h

DC centrifugal fans

Series RER 160 NTD 165 Ø x 51 mm



Highlights:

- Control inputs, alarm and speed signals available on request.
- 3-phase fan drive with high degree of running smoothness.
- High pressure build-up.
- Backward curved impeller.

General characteristics:

- Fibreglass-reinforced plastic scroll housing and impeller; Housing base of steel plate.
- Fully integrated electronic commutation.
- Direction of air flow: axial air intake, centrifugal air exhaust out of the outlet.
- Connection via single strands AWG 22, TR 64. Bared and tin-plated.
- Mass: 590 g.

Nominal data		Air flow	Air flow	Nominal voltage	Voltage range	Sound power level	Sinter sleeve bearings Ball bearings	Power input	Nominal speed	Temperature range	Service life L ₁₀ (40 °C) ebm-papst Standard	Service life L ₁₀ (T _{max}) ebm-papst Standard	Life expectancy L ₁₀ Δ (40 °C) see P. 15	Curve	Specials
Type		m ³ /h	CFM	VDC	VDC	Bel(A)	■ / ■	Watts	RPM	°C	Hours	Hours		P.	
NEW	RER 160-28/14N/2TDA	370	217	24	16...28	7,4	■	51	4 200	-20...+60	55 000 / 27 500	110 000	2		
NEW	RER 160-28/18N/2TDHHP*	505	297,5	48	36...60	8,5	■	142	6 000	-20...+65	40 000 / 22 500	80 000	3		
min. max.	RER 160-28/18 NTD...	66	18,3	48	38...57	—	■	2,0	800	-20...+70	55 000 / 27 500	110 000	1		
		354	98,3					43,0	4 200				2		

Model RER 160-28/18 NTD... is available in customer-specific, custom-developed variant only.

The data specified here are technically feasible benchmark values. The fans can be specially adapted to your application with signal outputs and control inputs.

*The specific service life is valid when an external capacitor is wired between the plus and minus strands.

Please note the wiring suggestion.

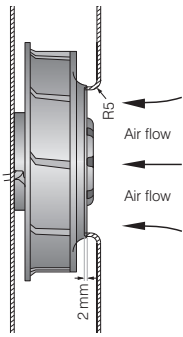

The air flow and noise level of fans without external housing depends on the installation conditions. The stated air flow and noise levels have been measured under the following conditions:
Centrifugal fan mounted on a base plate 260 x 260 mm.
Cover plate 260 x 260 mm with an air inlet of Ø 100 mm, concentric to the impeller.

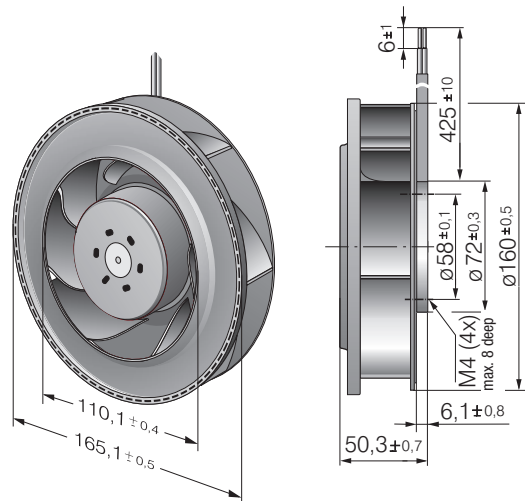
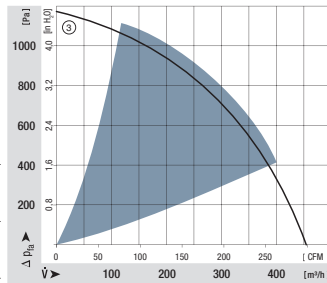
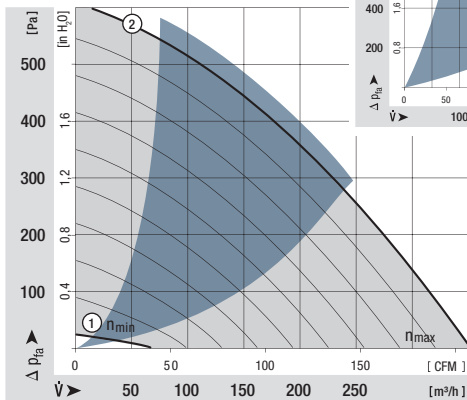

max. 800 m³/h

DC centrifugal fans

Series REF 175 TD 175 Ø x 55 mm



Highlights:

- 3-phase fan drive with high degree of running smoothness.
- Very high pressure build-up. Backward curved impeller.
- Available as standard with PWM control input and speed signal. Additional inputs and outputs on request.

General characteristics:

- Impeller of galvanised steel plate.
- Fully integrated electronic commutation.
- Direction of rotation: CW seen on rotor.
- Direction of air flow: axial air intake, centrifugal air exhaust out of the outlet.
- Connection via single strands AWG 20, TR 64, speed signal and control input AWG 22, bared and tin-plated.
- Mass: 930 g.

Nominal data		Air flow	Air flow	Nominal voltage	Voltage range	Sound power level	Sinter sleeve bearings Ball bearings	Power input	Nominal speed	Temperature range	Service life L ₁₀ (40 °C) ebm-papst Standard	Service life L ₁₀ (T _{max}) ebm-papst Standard	Life expectancy L ₁₀ ^Δ (40 °C) see P. 15	Curve	Specials
Type		m ³ /h	CFM	VDC	VDC	Bel(A)	■ / ■	Watts	RPM	°C	Hours	Hours	Hours		
NEW	REF 175-30/18/2TDP	800	470	48	36 ... 72	8,3	■	121	4 400	-20...+60	65 000 / 37 500	130 000	1		

Speed control range from 800 rpm at 7 % PWM up to nominal speed at > 90 % PWM. Standstill at 0 % PWM, max. speed if control cable is interrupted.

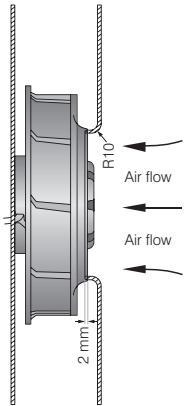

The air flow and noise level of fans without external housing depends on the installation conditions. The stated air flow and noise levels have been measured under the following conditions:
Centrifugal fan mounted on a base plate 180 x 180 mm.
Cover plate 180 x 180 mm with an air inlet of Ø 125,5 mm, concentric to the impeller.

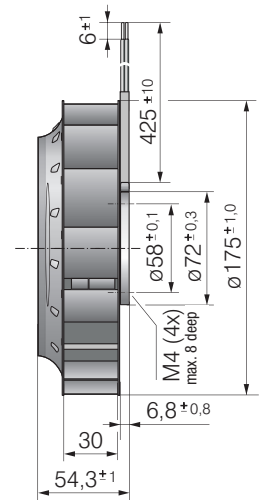
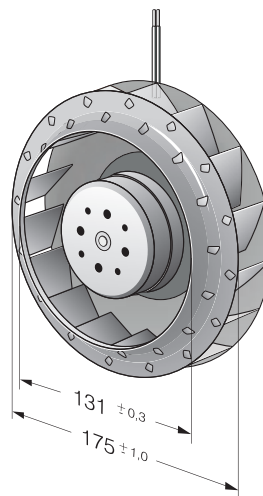
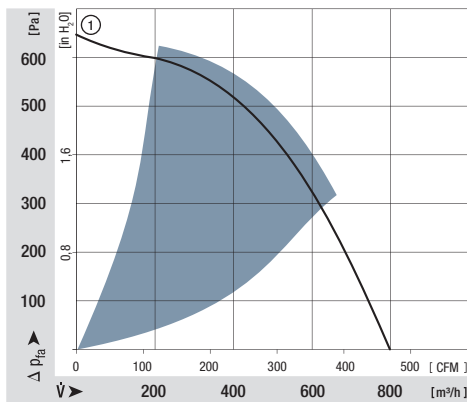

max. 980 m³/h

DC centrifugal fans

Series RER 175 TD 175 Ø x 69 mm



Highlights:

- 3-phase fan drive with high degree of running smoothness.
- Very high pressure build-up. Backward curved impeller.
- Available as standard with PWM control input and speed signal. Additional inputs and outputs on request.

General characteristics:

- Impeller of fibreglass-reinforced plastic.
- Fully integrated electronic commutation.
- Direction of rotation: CW seen on rotor.
- Direction of air flow: axial air intake, centrifugal air exhaust out of the outlet.
- Connection via single strands AWG 18, 20 or AWG 22, TR 64, speed signal and control input AWG 22, bared and tin-plated.
- Mass: 775 g.

Nominal data		Air flow	Air flow	Nominal voltage	Voltage range	Sound power level	Sinter sleeve bearings Ball bearings	Power input	Nominal speed	Temperature range	Service life L ₁₀ (40 °C) ebm-papst Standard	Service life L ₁₀ (T _{max}) ebm-papst Standard	Life expectancy L ₁₀ Δ (40 °C) see P. 15	Curve	Specials
Type		m ³ /h	CFM	VDC	VDC	Bel(A)	■ / ■	Watts	RPM	°C	Hours	Hours			
NEW	RER 175-42/14/2 TDMLP	600	353,0	24	16...30	7,3	■	45	3 400	-20...+65	72 500 / 45 000	145 000	1		
NEW	RER 175-42/14/2 TDMP	865	508,8	24	16...36	8,2	■	110	4 800	-20...+65	70 000 / 40 000	140 000	2		
NEW	RER 175-42/18/2 TDMLP	600	353,0	48	36...57	7,3	■	46	3 400	-20...+65	72 500 / 45 000	145 000	1		
NEW	RER 175-42/18/2 TDMP*	865	508,8	48	36...72	8,2	■	110	4 800	-20...+65	70 000 / 40 000	140 000	2		
NEW	RER 175-42/18/2 TDP	980	576,8	48	36...72	8,5	■	166	5 400	-20...+65	60 000 / 32 500	115 000	3		

* preliminary data

Speed control range from 800 rpm at 7 % PWM up to nominal speed at > 90 % PWM. Standstill at 0 % PWM, max. speed if control cable is interrupted.

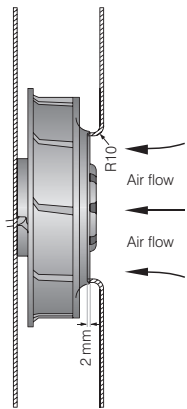

The air flow and noise level of fans without external housing depends on the installation conditions. The stated air flow and noise levels have been measured under the following conditions:
Centrifugal fan mounted on a base plate 180 x 180 mm.
Cover plate 180 x 180 mm with an air inlet of Ø 125,5 mm, concentric to the impeller.

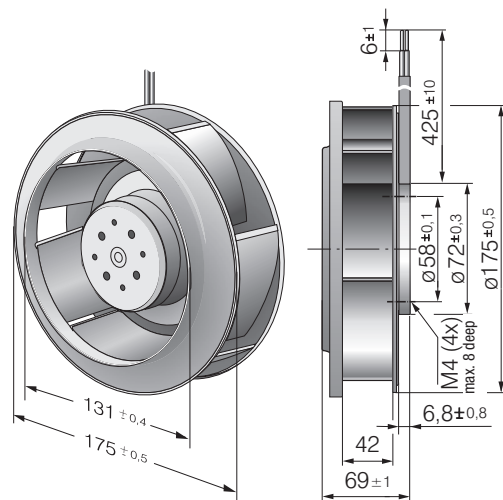
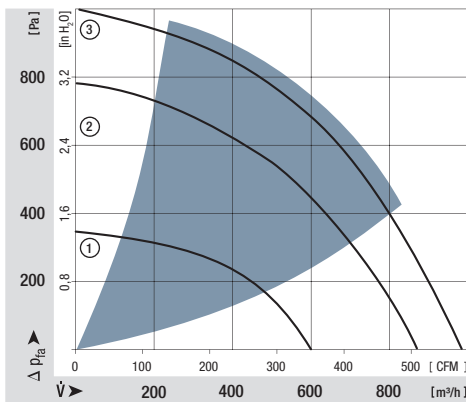

max. 970 m³/h

DC centrifugal fans

Series RER 190 TD 190 Ø x 69 mm



Highlights:

- 3-phase fan drive with high degree of running smoothness.
- Very high pressure build-up.
- Backward curved RadiCal impeller with maximum efficiency.
- Standard models available with multifunctional control input for analogue, PWM and speed signal.

General characteristics:

- Impeller of fibreglass-reinforced plastic.
- Fully integrated electronic commutation.
- Direction of rotation: CW seen on rotor.
- Direction of air flow: axial air intake, centrifugal air exhaust out of the outlet.
- Connection via single strands AWG 18, 20 or AWG 22, TR 64, speed signal and control input AWG 22, bared and tin-plated.
- Mass: 870 g.

Nominal data		Air flow	Air flow	Nominal voltage	Voltage range	Sound power level	Sinter sleeve bearings Ball bearings	Power input	Nominal speed	Temperature range	Service life L ₁₀ (40 °C) ebm-papst Standard	Service life L ₁₀ (T _{max}) ebm-papst Standard	Life expectancy L ₁₀ Δ (40 °C) see P. 15	Curve	Specials
Type		m ³ /h	CFM	VDC	VDC	Bel(A)	■ / ■	Watts	RPM	°C	Hours	Hours	Hours		
NEW	RER 190-39/14/2TDML0	650	382,4	24	16...30	7,6	■	58	3 000	-20...+60	55 000 / 35 000	110 000	110 000	1	
NEW	RER 190-39/14/2TDM0	860	505,9	24	16...36	7,9	■	110	3 900	-20...+65	52 500 / 30 000	105 000	105 000	2	
NEW	RER 190-39/18/2TDML0	650	382,4	48	36...57	7,6	■	56	3 000	-20...+65	55 000 / 35 000	110 000	110 000	1	
NEW	RER 190-39/18/2TDM0	860	505,9	48	36...72	7,9	■	105	3 900	-20...+65	52 500 / 30 000	105 000	105 000	2	
NEW	RER 190-39/18/2TDO	970	570,6	48	36...72	8,3	■	148	4 400	-20...+65	40 000 / 22 500	80 000	80 000	3	

Speed control range from 800 rpm at 7 % PWM up to nominal speed at > 90 % PWM. Standstill at 0 % PWM, standstill if control cable is interrupted.

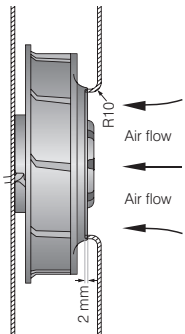

The air flow and noise level of fans without external housing depends on the installation conditions. The stated air flow and noise levels have been measured under the following conditions:
Centrifugal fan mounted on a base plate 195 x 195 mm.
Cover plate 195 x 195 mm with an air inlet of Ø 125,5 mm, concentric to the impeller.

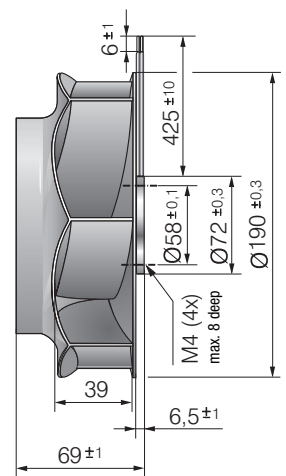
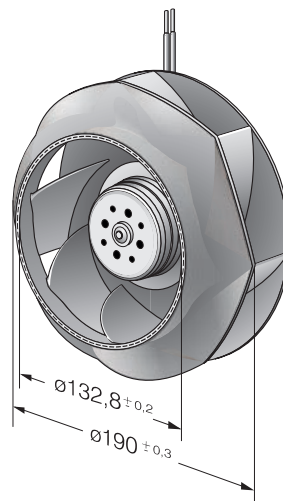
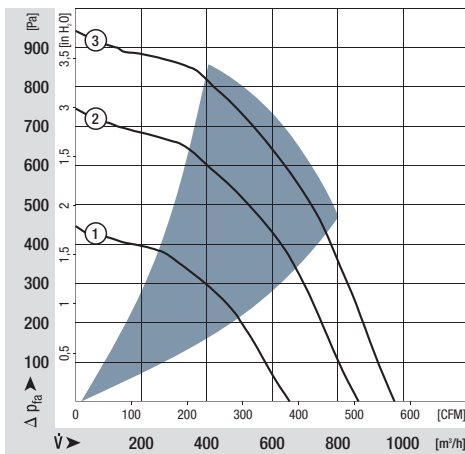

max. 1280 m³/h

DC centrifugal fans

Series RER 220 TD 221 Ø x 71 mm



Highlights:

- 3-phase fan drive with high degree of running smoothness.
- Very high pressure build-up.
- Backward curved impeller.
- Standard models available with multifunctional control input for analogue, PWM and speed sign.

General characteristics:

- Impeller of fibreglass-reinforced plastic.
- Fully integrated electronic commutation.
- Direction of rotation: CW seen on rotor.
- Direction of air flow: axial air intake, centrifugal air exhaust out of the outlet.
- Connection via single strands AWG 18, 20 or AWG 22, TR 64, speed signal and control input AWG 22, bared and tin-plated.
- Mass: 940 g.

Nominal data		Air flow	Air flow	Nominal voltage	Voltage range	Sound power level	Sinter sleeve bearings Ball bearings	Power input	Nominal speed	Temperature range	Service life L ₁₀ (40 °C) ebm-papst Standard	Service life L ₁₀ (T _{max}) ebm-papst Standard	Life expectancy L ₁₀ Δ (40 °C) see P. 15	Curve	Specials
Type		m ³ /h	CFM	VDC	VDC	Bel(A)	■ / ■	Watts	RPM	°C	Hours	Hours			
NEW	RER 220-44/14/2TDMO	1090	641,2	24	16...36	7,7	■	82	3 000	-20...+55	75 000 / 52 500	150 000	1		
NEW	RER 220-44/18/2TDMO	1090	641,2	48	36...72	7,7	■	80	3 000	-20...+55	75 000 / 52 500	150 000	1		
NEW	RER 220-44/18/2TDO	1280	752,9	48	36...72	8,0	■	140	3 500	-20...+55	55 000 / 40 000	110 000	2		

Speed control range from 800 rpm at 7 % PWM up to nominal speed at > 90 % PWM. Standstill at 0 % PWM, standstill if control cable is interrupted.

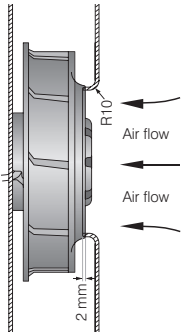

The air flow and noise level of fans without external housing depends on the installation conditions. The stated air flow and noise levels have been measured under the following conditions:
Centrifugal fan mounted on a base plate 230 x 230 mm.
Cover plate 230 x 230 mm with an air inlet of Ø 146 mm, concentric to the impeller.

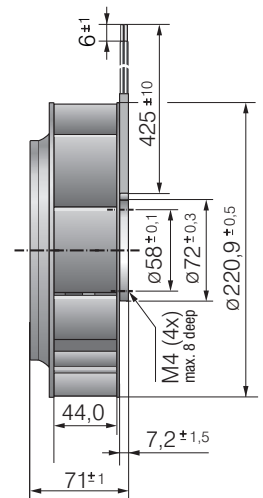
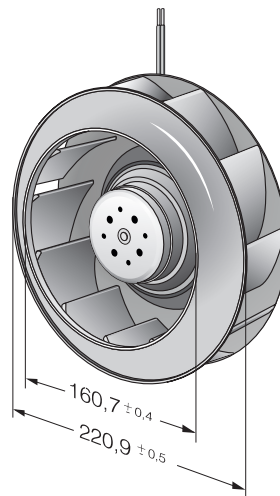
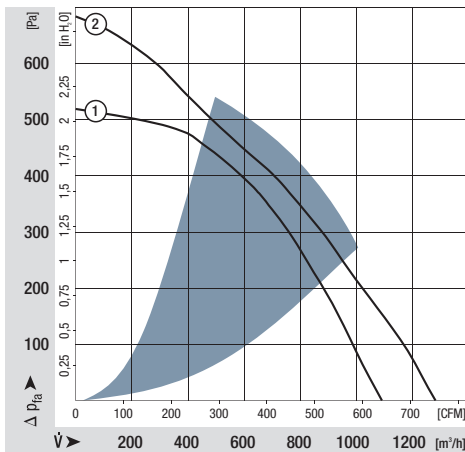

max. 1600 m³/h

DC centrifugal fans

Series RER 225 TD 225 Ø x 99 mm



Highlights:

- 3-phase fan drive with high degree of running smoothness.
- Very high pressure build-up.
- TDM and TDML model with backward-curved RadiCal impeller with maximum efficiency.
- Standard models available with multifunctional control input for analogue, PWM and speed signal.

General characteristics:

- Impeller of fibreglass-reinforced plastic.
- Fully integrated electronic commutation.
- Direction of rotation: CW seen on rotor.
- Direction of air flow: axial air intake, centrifugal air exhaust out of the outlet.
- Connection via single strands AWG 18, 20 or AWG 22, TR 64, speed signal and control input AWG 22, bared and tin-plated.
- Mass: 1030 g.

Nominal data		Air flow	Air flow	Nominal voltage	Voltage range	Sound power level	Sinter sleeve bearings Ball bearings	Power input	Nominal speed	Temperature range	Service life L ₁₀ (40 °C) ebm-papst Standard	Service life L ₁₀ (T _{max}) ebm-papst Standard	Life expectancy L ₁₀ ^Δ (40 °C) see P. 15	Curve	Specials
Type		m ³ /h	CFM	VDC	VDC	Bel(A)	■ / ■	Watts	RPM	°C	Hours	Hours	Hours		
NEW	RER 225-55/18/2TDML0	1080	635,4	48	36...72	7,5	■	82	2 500	-20...+55	70 000 / 50 000	140 000	140 000	1	
NEW	RER 225-55/18/2TDM0	1210	711,9	48	36...72	7,9	■	120	2 800	-20...+55	55 000 / 40 000	110 000	110 000	2	
NEW	RER 225-63/18/2TDP-402	1600	941,3	48	36...72	8,1	■	165	3 300	-20...+55	52 500 / 37 500	105 000	105 000	3	

Speed control range from 800 rpm at 7 % PWM up to nominal speed at > 90 % PWM. Standstill at 0% PWM, Type O: standstill at sensor break. Type P: maximum speed at sensor break.

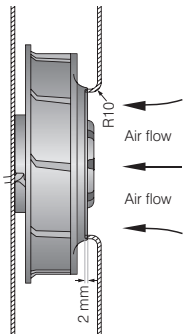

The air flow and noise level of fans without external housing depends on the installation conditions. The stated air flow and noise levels have been measured under the following conditions:
Centrifugal fan mounted on a base plate 230 x 230 mm.
Cover plate 230 x 230 mm with an air inlet of Ø 146 mm, concentric to the impeller.

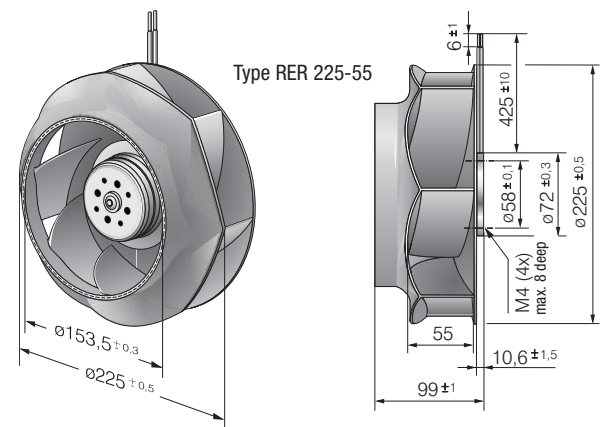
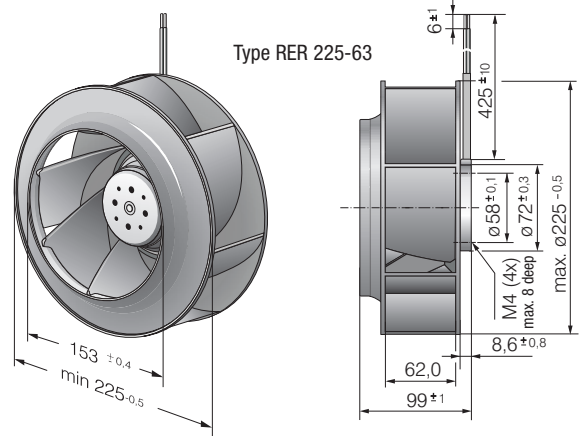
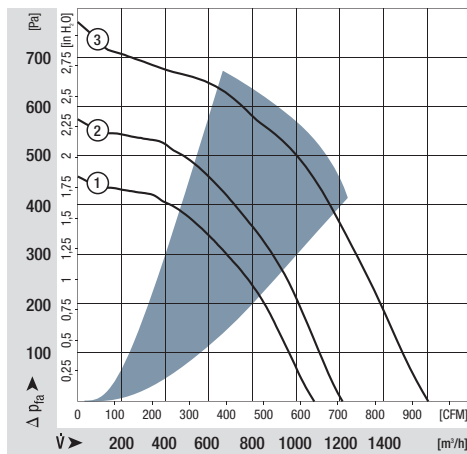

max. 155 m³/h

DC tangential fan

Series QG 030 201...413 x 50 x 48 mm

Highlights:

- Tangential fans with high air flow.
- Large air outlet.

General characteristics:

- Motor with ball bearing system. Impeller mounting plate with sleeve bearings.
- Fan housing and impeller of aluminium. Plastic housing side parts.
- Fully integrated electronic commutation.
- Protected against reverse polarity and locking.
- Air exhaust out of the outlet.
- Connection via single strands. Bared and tin-plated.
- Mass: 235 / 290 / 380 / 415 g.

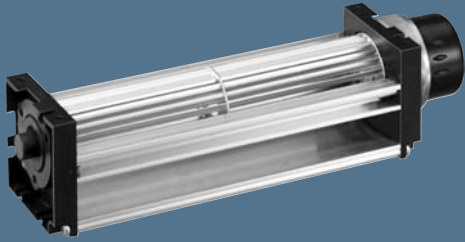

Nominal data	Air flow		Nominal voltage	Voltage range	Sound pressure level	Sound power level	Sleeve bearings Ball bearings	Power input	Temperature range	Service life L ₁₀ (40 °C) ebm-papst Standard	Service life L ₁₀ (T _{max}) ebm-papst Standard	Life expectancy L ₁₀ Δ (40 °C) see P. 15	Curve	Specials
	m ³ /h	CFM												
QG 030-148/12	75	44,1	12	8...14	49	5,7	□ / ■	6,2	-20...+60	30 000 / 10 000	32 500	1		
QG 030-198/12	100	58,9	12	8...14	51	5,8	□ / ■	8,0	-20...+60	30 000 / 10 000	32 500	2		
QG 030-303/12	140	82,4	12	8...14	51	5,8	□ / ■	8,7	-20...+60	30 000 / 10 000	32 500	3		
QG 030-353/12	155	91,3	12	8...14	51	5,9	□ / ■	9,6	-20...+60	30 000 / 10 000	32 500	4		
QG 030-148/14	75	44,1	24	16...28	49	5,7	□ / ■	6,2	-20...+60	30 000 / 10 000	32 500	1		
QG 030-198/14	100	58,9	24	16...28	51	5,8	□ / ■	8,0	-20...+60	30 000 / 10 000	32 500	2		
QG 030-303/14	140	82,4	24	16...28	51	5,8	□ / ■	8,7	-20...+60	30 000 / 10 000	32 500	3		
QG 030-353/14	155	91,3	24	16...28	51	5,9	□ / ■	9,6	-20...+60	30 000 / 10 000	32 500	4		

Tangential fans are only suitable for operation with high rate and low back pressure.

Type	Dimension:	L	L ₁
QG 030-148/ ..		201 ^{+1,5}	148
QG 030-198/ ..		258 ^{+1,5}	198
QG 030-303/ ..		363 ^{+1,5}	303
QG 030-353/ ..		413 ^{+1,5}	353

The service life values refer to horizontal installation of the fan.

