

MARKETING SALES DRAWING

DIMENSIONS IN INCHES - DO NOT SCALE THIS DRAWING
DIMENSIONS IN METRIC - []

Electrical Testing
 per Tusonix standard
 test plans and Mil-Std-202
 Test Methods.

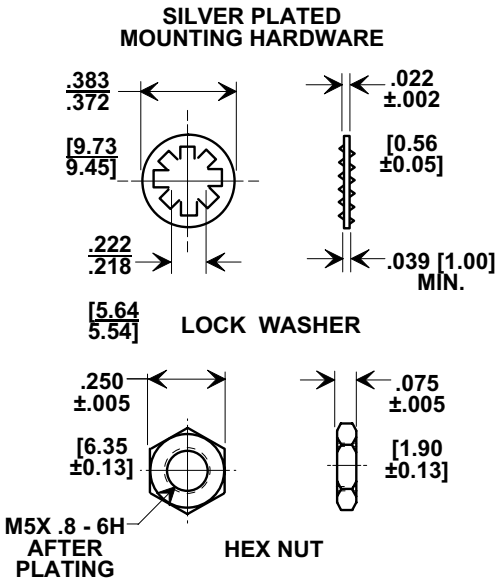
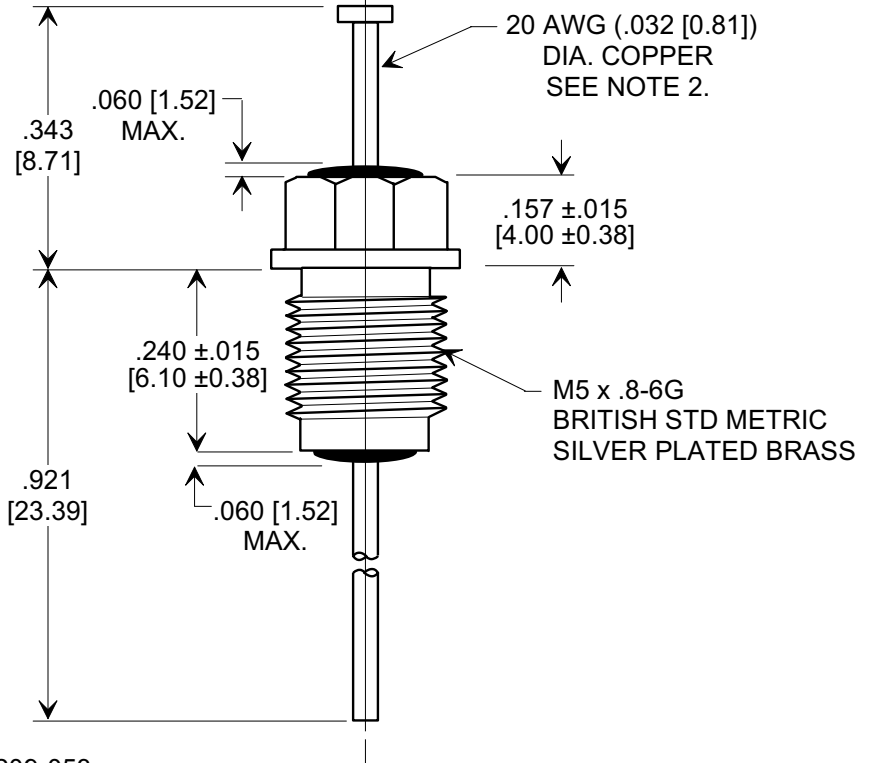
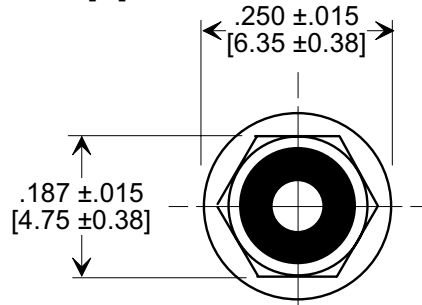
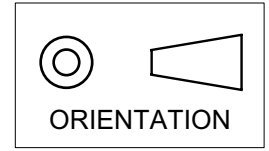

NOTES:

- TUSONIX STANDARD PART NUMBER: 4209-053.
 TUSONIX RoHS COMPLIANT PART NUMBER: 4209-053 LF.
 CUSTOMER MUST SPECIFY STANDARD OR RoHS PART NUMBER WHEN ORDERING.
- LEAD FINISH: STANDARD PART #: 60/40 SOLDER PLATED. RoHS PART #: SILVER PLATED.
- PART MARKING: TRADEMARK AND VARIATION NUMBER ON HEX FLATS.
 STANDARD PART: BLACK INK. RoHS PART: GREEN INK.

5500	350	100	10 A	I.R. MIN. @ 100 (VDC.)	DWV	20	65	70	70
	85°C	125°C				10	100	1	10
MIN. CAP. (pF)	WORKING VOLTAGE (WVdc)		CURRENT IDC	10 G	700 vdc	MINIMUM NO LOAD INSERTION LOSS (dB) AT 25°C PER MIL-STD -220			

X-2015 Rev-0

REVISION RECORD	Original Release	0	<p>-- TOLERANCES -- Unless Otherwise Specified</p>	Title BUSHING STYLE EMI FILTER		
	C.O.	4668		Drawn	S.M. 10-20-98	
	WVDC 85°C WAS 200.	1		Approved	S.C. 10-20-98	
	E.C. 03-18-97			A	4209-053	
	970318-2	20050418-1-02				
	RDN TO COMP FMT & ADDED L WASHER, HET NUT & NOTE 1.					
S.M. 10-20-98						
19981019-5-01						
ADDED METRIC, CIRCUIT & ORIENTATION. S.M. 12-18-01						
20011210-2-04						
CAP WAS 5000. FIXED METRIC						
2 PLCS. S.M. 07-14-03						
20030711-1-01						
SOLDER PLATED, SOLDER PLATED COPPER, SILVER PLATED BRASS & IR MIN. @ 100						
VDC & DWV COLUMNS ADDED & NOTE DELETED L.E. 01-30-04						
20040130-1-01						
ADDED NOTES. S.M. 04-22-05						
20050418-1-02						