

REDRING®

MW & EW 10 & 15 Litre Unvented Water Heaters

HANDBOOK

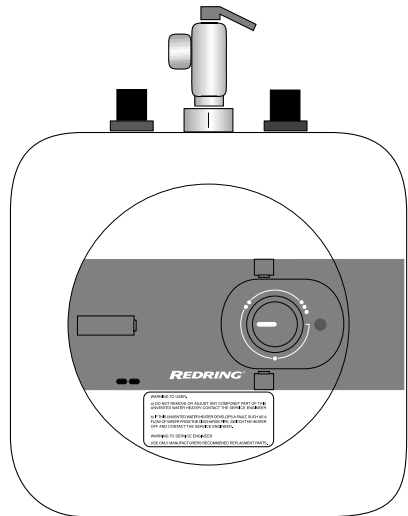
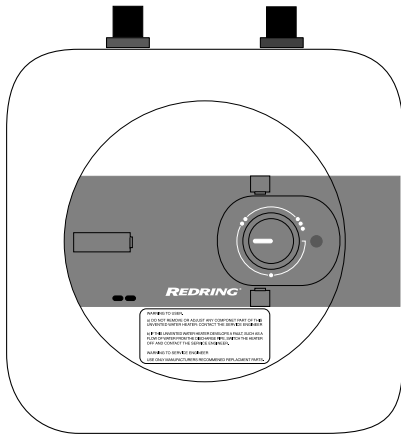

IMPORTANT:

This booklet should be given to the customer after installation and demonstration.

applied energy///

Description of water heater

- 1) Hot water outlet
- 2) Temperature and pressure relief valve (MW only)
- 3) Cold water inlet
- 4) Control cover
- 5) Regulation knob
- 6) Heating neon

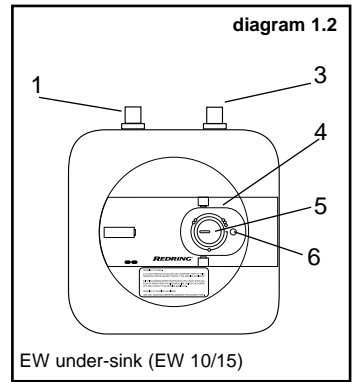
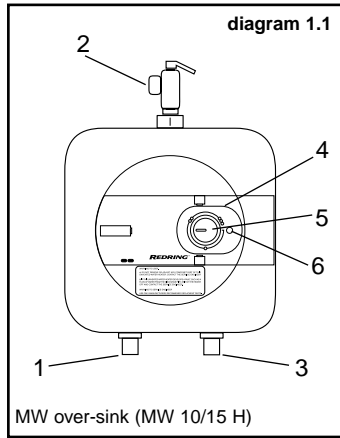
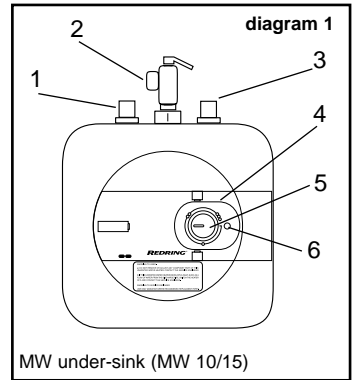

Technical data

MODEL	EW 10	EW 15	MW 10 MW 10 H	MW 15 MW 15 H
Approved	BEAB/WRAS		BEAB/WRAS	
Capacity (litres)	10	15	10	15
Current (A)	13		13	
Voltage (V~)	230-240 (50/60 Hz)		230-240 (50/60 Hz)	
Power (W)	2755-3000		2755-3000	
Pressure max.	6 bar			
T & P valve	n/a		90°C/7bar	
Weight with water	18 kg	24 kg	18 kg	24 kg
Moisture protection	DRIP PROOF 			

User Instructions

PLEASE KEEP THIS BOOKLET FOR FUTURE REFERENCE

The heater is insulated to a high standard therefore it may be left on all the time. The temperature of the water may be adjusted by turning the knob on the front of the heater, allow half an hour for the temperature to stabilise between settings. Maximum temperature is achieved with the knob turned fully clockwise. The -- mark on the regulation knob indicates an "economy" setting and corresponds to a water temperature of 55 - 60°C. In hard water areas we recommended a max. 60°C. The neon light shows when the heating element is working, under control of the thermostat. If in doubt ring Applied Energy Products Service Dept. on 08709 000430.

Water Regulations

These regulations ensure a good supply of wholesome water, and that only approved materials, pipes and fittings are used to convey water.

Delivery

There are two options available, the MW range and the EW range.

The MW is supplied with the following:

MW unvented water heater (with factory-fitted T + P valve)	x1
Wall bracket	x1
Tundish	x1
Dielectric junction	x2

The EW is supplied with the following:

EW unvented water heater	x1
Wall bracket	x1
Pressure relief valve set at 6 bar	x1
Dielectric junction	x2

How the heater works

The heating element is controlled by a capillary thermostat . The operating temperature can be adjusted by the regulation knob on the front of the heater. In addition to the thermostat there is a thermal cut-out which is set to switch off the power to the element if the thermostat fails and the water temperature rises too high. Once the cut-out operates it can only be reset manually (this should be carried out by the installer - see maintenance).

A magnesium anode is provided to prevent corrosion of the water container. The MW has a temperature and pressure relief valve on top of the heater which is a safety device to back-up the thermostat and thermal cut-out. It works by sensing an excess water temperature or pressure and releasing the hot water to the discharge tundish and drain.

The heater will only work in the vertical position as the element is shaped to heat the water at the bottom of the tank. The inlet pipe needs to deliver cold water to the bottom of the tank and the hot water outlet draws water from the top of the tank.

When water is heated it expands. In a small unvented water heater of this type the expansion can normally be accommodated back into the cold water mains, as indicated in the Water Regulations.

Where this is not possible the installer will need to fit a set of cold water controls.

Installation Instructions

Before installing the heater read these instructions in full. If you are unsure please contact our technical department (01733) 456999.

The installation must comply with all relevant Water and Building Regulations.

The installer should check with the local water authority for confirmation of the maximum water supply pressure.

a) Siting & fixing

WARNING: When unpacking MW models take care not to damage the temperature and pressure relief valve on the top of the heater.

A drain has to be provided for any water discharged through the safety valves. Access to the heater is not normally needed on a day-to-day basis.

A cold water supply pressure between 1 and 5.5 bar is required (if the mains pressure is above 5.5 bar a pressure reducing valve will need to be installed).

Please note that turning down the stop-cock will reduce flow not pressure.

The outlet pressure from the reducing valve (if supplied) is 3.5 bar.

A 240 VAC; 3 kW single phase electrical supply is required.

Position the heater against the wall and mark the position of the hooked wall bracket. Fasten the wall bracket to wall using suitable screws and wall plugs (allowing for the extra weight of water when the unit is full). Hang the heater on the bracket making sure that the heater is pulled well down on to the bracket, if necessary by forcing the hooks into the foam insulation.

b) Plumbing

WARNING: The outlet from temperature and pressure relief valve/pressure relief valve must not be for any other purpose.

Take great care not to allow any swarf into the pipe work or fittings, as this might impair the operation of the safety valve(s).

The water connection may be carried out as per the following:

1) Accommodation of the expansion in supply pipe work (diagrams 2 & 3).

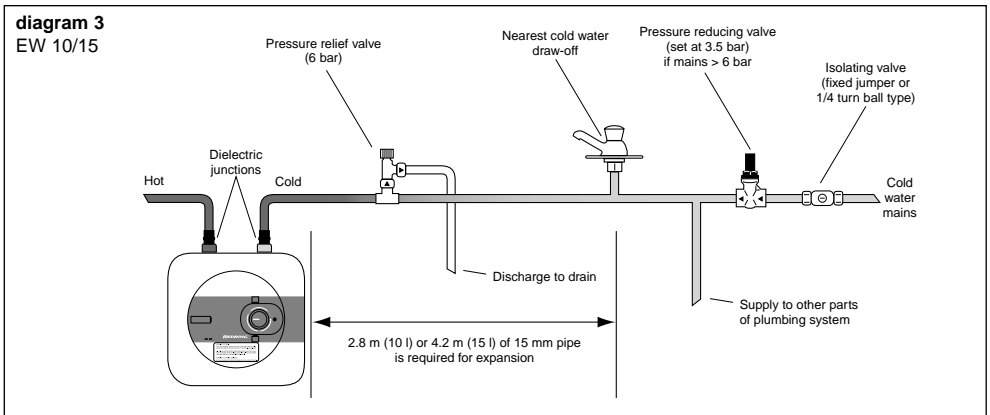
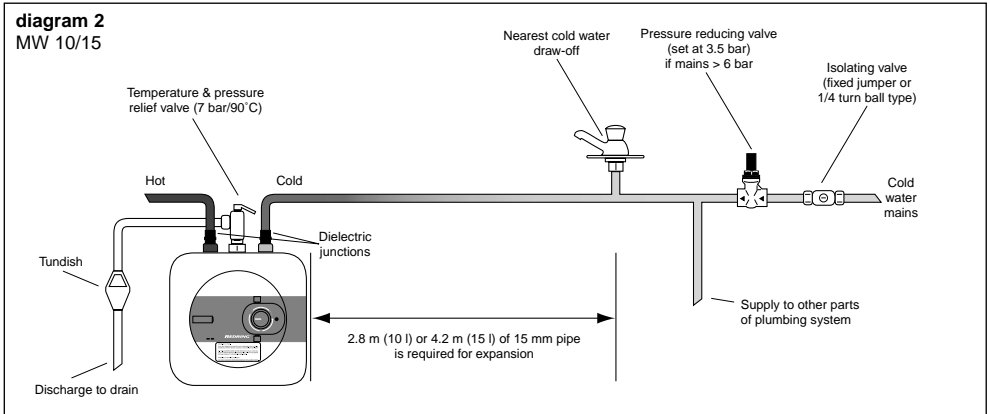

Do not fit any stop-cocks or non-return valves within the distance required for expansion.

The distances quoted are for 15 mm pipe these can be approximately halved for 22 mm pipe to shorten the distance required for expansion.

2) Accommodation of expansion in an expansion vessel (diagrams 4 & 5).

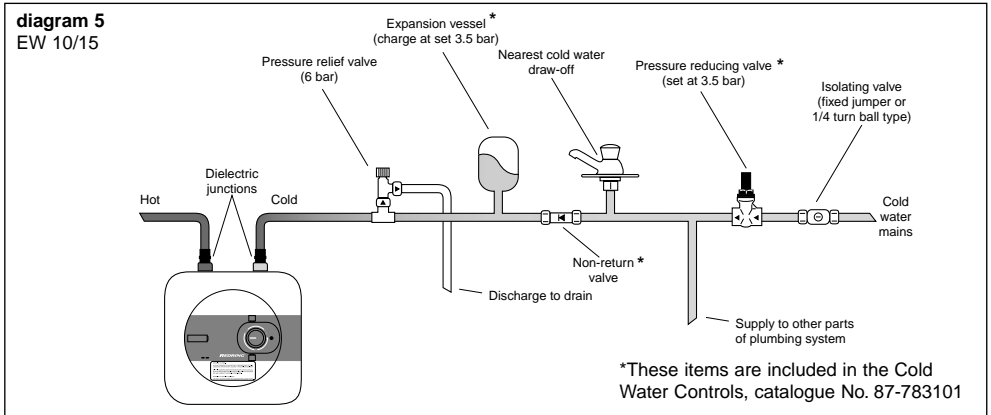
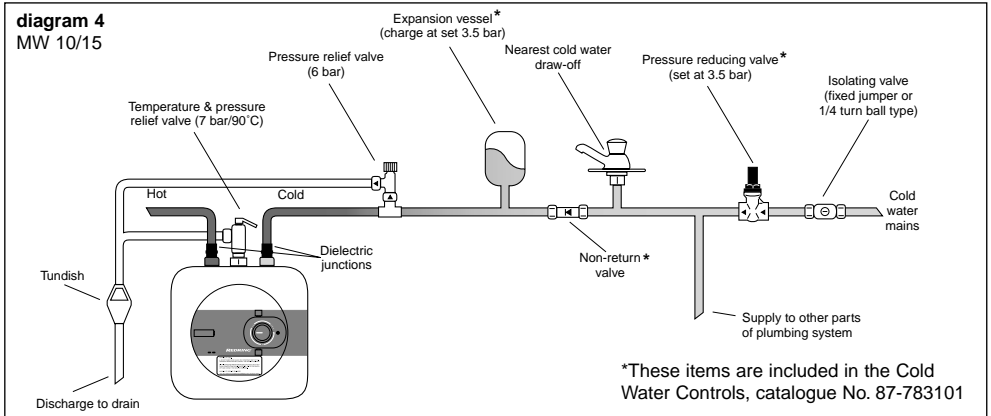

Using a pressure reducing valve (set at 3.5 bar), a non-return valve and expansion vessel charged to 3.5 bar, the expansion is accommodated in the vessel. This operates on the hydraulic principle; i.e. the expanded water is forced into the expansion vessel due to the in-line non-return valve. The vessel pressure charge is increased as it accommodates the expanded water, so that the water is discharged from the vessel when the hot draw off is opened.

Please note that in all cases the dielectric junctions must be connected to the heater before any other connection is made (these prevent an electrolytic reaction).

Only the use of copper pipe is recommended for connection to the heater. If any other material is used it must be able to withstand 90°C at 7 bar pressure for long periods.

c) Discharge pipe work

NOTE: The following guidelines refer to Building Regulation G3. This regulation only applies to an unvented system over 15 litres. It is good practice to adopt the same principles for the EW and MW range.

1) The tundish must be vertical and fitted within 500 mm of the temperature & pressure relief valve and must be located with the water heater. The tundish must also be in a position visible to the occupants, and positioned away from any electrical devices. The discharge pipe from the tundish should terminate in a safe place where there is no risk to persons in the vicinity of the discharge and to be of metal.

2) Discharge pipes from the temperature & pressure relief and pressure relief valve may be joined together.

3) The pipe diameter must be at least one pipe size larger than the nominal outlet size of the safety device unless its total equivalent hydraulic resistance exceeds that of a straight pipe 9 m long.

i.e. Discharge pipes between 9 m and 18 m equivalent resistance length should be at least 2 sizes larger than the nominal outlet size of the safety device.

Between 18 m and 27 m at least 3 times larger, and so on.

Bends must be taken into account in calculating the flow resistance.

See diagram.6 and Table 2.

4) The discharge pipe must have a vertical section of pipe at least 300 mm in length, below the tundish before any elbows or bends in the pipe work.

5) The discharge pipe must be installed with a continuous fall.

6) The discharge must be visible at both the tundish and the final point of discharge, but where this is not possible or practically difficult; there should be clear visibility at one or other of these locations. Examples of acceptance are:

i) Ideally below a fixed grating and above the water seal in a trapped gully.

ii) Downward discharges at a low level; i.e. up to 100 mm above external surfaces such as car parks, hard standings, grassed areas etc. These are acceptable

providing that where children may play or otherwise come into contact with discharges, a wire cage or similar guard is positioned to prevent contact, whilst maintaining visibility.

- iii) Discharges at high level; i.e. into a metal hopper and metal down pipe with the end of the discharge pipe clearly visible (tundish visible or not). Or onto a roof capable of withstanding high temperature discharges of water 3 m from any plastic guttering systems that would collect such a discharge (tundish visible).
- iv) Where a single pipe serves a number of discharges, such as in blocks of flats, the number served should be limited to not more than 6 systems so that any installation can be traced reasonably easily. The single common discharge pipe should be at least one pipe size large than the largest individual discharge pipe to be connected. If unvented hot water storage systems are installed where discharges from safety devices may not be apparent i.e. in dwellings occupied by the blind, infirm or disabled people, consideration should be given to the installation of an electronically operated device to warn when discharge takes place. Note: The discharge will consist of scalding water and steam. Asphalt, roofing felt and non-metallic rainwater goods may be damaged by such discharges.

diagram 6

Suggested ways of terminating discharge pipes safely

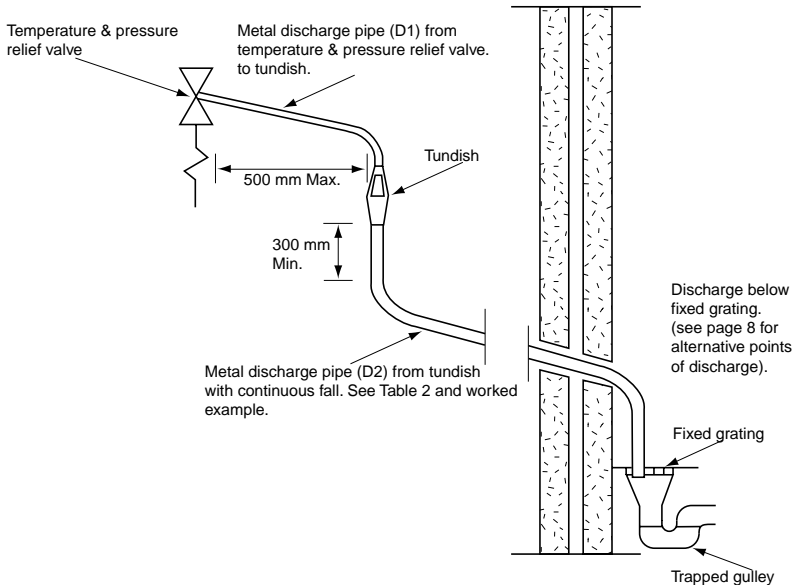

Table 2

Sizing of copper discharge pipe “D2” for common temperature valve outlets.

Valve outlet size	Minimum size of discharge pipe D1*	Minimum size of discharge pipe D2* from tundish	Maximum resistance allowed, expressed as a length of pipe (i.e. no elbow or bends)	Resistance created by each elbow or bend
G 1/2	15 mm	22 mm	Up to 9 m	0.8 m
		28 mm	Up to 18 m	1.0 m
		35 mm	Up to 27 m	1.4 m
G 3/4	22 mm	28 mm	Up to 9 m	1.0 m
		35 mm	Up to 18 m	1.4 m
		42 mm	Up to 27 m	1.7 m
G 1	28 mm	35 mm	Up to 9 m	1.4 m
		42 mm	Up to 18 m	1.7 m
		54 mm	Up to 27 m	2.3 m

Worked example

The example below is for a G 1/2” temperature & pressure relief valve with a discharge pipe (D2) having 4 no. elbows and length of 7 m from the tundish to the point of discharge.

From Table 2

Maximum resistance allowed for a straight length of 22 mm copper discharge pipe (D2) from G 1/2 T & P valve is 9 m.

Subtract the resistance for 4 no. 22 mm elbows at 0.8 m each = 3.2 m.

Therefore the maximum permitted length equates to: 5.8 m.

As 5.8 m is less than the actual length of 7 m therefore calculate the next largest size.

Maximum resistance allowed for a straight length of 28 mm pipe (D2) from G 1/2” T & P valve equates to: 18 m.

Subtract the resistance for 4 no. 28 mm elbow at 1.0 m each = 4 m.

Therefore the maximum permitted length equates to: 14 m

As the actual length is 7 m a 28 mm (D2) copper pipe will be satisfactory.

d) Electrical

WARNING: The appliance must be earthed.

The electrical installation must be in line with the current I.E.E. wiring regulations. A mains supply of 230/240 VAC (BS 7671) 3 kW (13 amps) is required (diagram 7)

Heat resisting cable, round 3 core 1.5 mm (to BS 6141 table 8) should be used to connect to the electrical supply through either:

- a 13 amp socket to BS 1363; or

- a double pole fused isolating switch with a contact separation of 3 mm minimum on each pole.

The cable enters the terminal compartment through a tube embedded in the foam insulation, the entrance to this tube is on the right hand side at the bottom.

Flexible cables are colour coded as follows:

Brown..... live

Blue..... neutral

Green and yellow..... earth

Cut back cables to expose 10 mm of conductor for L, N, & E. Connect cable to terminal block making sure that all terminal screws are tight and that no cable insulation is trapped in the block. Ensure that the cable is retained within the clamp.

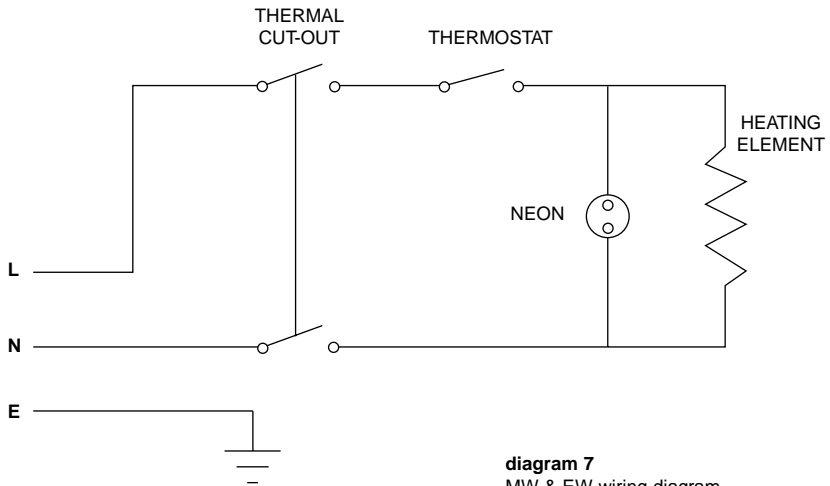

diagram 7
MW & EW wiring diagram

Access to the terminal compartment is gained by prising out the “model” nameplate, the two small inserts and then undoing the three screws revealed.

NOTE: The earth terminal is located on the heating element securing bracket in the centre of the appliance.

e) Commissioning

- Check that all the necessary components are supplied and for those not factory fitted, that they are the type recommended by the manufacturer for the particular water heater.
- Check that the water heater/components are undamaged.
- Check that the discharge pipe is plumbed so that it falls continuously and that no taps or valves or other shut-off devices are installed in the pipe.

- Check that the discharge pipe drains safely to waste and is readily visible.
- Check, in the case where some components are not factory fitted, that they are marked so as to refer to the warning label on the water heater.
- Open all outlet taps.
- Turn on the mains water supply.
- Close taps in turn as water flow stabilises with no air bubbles.
- Check for leaks.
- Check that no water is passing through the safety valve(s).
- Test the operation of the safety valve(s) by lifting/turning the lever/knob, and observing that water flows through and safely to waste.
- Switch on electricity and set thermostat.
- Check the water heats up.
- Check that “warning to user label” is secure and visible on the heater and related warning labels are fitted to the controls.
- Demonstrate operation to user, including operation of safety valve(s) and what to do if it/they operate(s).
- Give this handbook to the user and discuss future maintenance.

Maintenance

a) For the user

In order to obtain the best performance from the heater, the sacrificial anode must be checked every year. If the heating element is heavily coated with scale we recommend descaling at the time of this inspection. Where the additional cold water controls are fitted, the expansion vessel will need to be recharged by the installer.

b) For the installer

WARNING: Switch off the power first

Access to the electrical components, the magnesium anode and water container is gained by unscrewing the 4 screws on the front cover.

If the thermal cut-out has operated the cause must be found before resetting.

To drain the heater close the service valve and:

- i) for under-sink models (MW 10/15 - EW 10/15) disconnect pipes and remove the heater from the wall.
- ii) for over-sink models (MW 10 H - MW 15 H) undo the cold water supply pipe and open a hot water tap.
The heating element may be removed after taking out the thermostat phials by undoing the M6 nut.
The assembly should then be turned through 90° anti-clockwise to ease removal from the water container.

Once the element is free from the water container the anode may then be inspected and removed if necessary.

When reassembling the cover make sure that the regulation knob is coupled with the thermostat.

Fault finding

- 1) Pressure and temperature valve dripping/running all the time.
Cause: Thermal cut-out and thermostat have failed (this is only the case if the water being discharged is near to boiling).
Mains pressure is above 7 bar. A pressure reducing valve must be fitted (see page 6, diagram 2).
- 2) Pressure relief valve dripping/running all the time.
Cause: Mains pressure is above 6 bar. A pressure reducing valve must be fitted (see page 6, diagram 3).
- 3) Dripping while unit heating.
Cause: Not enough pipe work for expansion; or stop-cock, non-return valve or pressure reducing valve has been fitted within the distance required for expansion (see page 7, diagrams 4 & 5). If an expansion vessel has been fitted, the charge may have failed.
- 4) No hot water.
Cause: Thermal cut-out has operated.
The heating element has burnt-out.
The thermostat is faulty.
- 5) Milky water.
Cause: This is a result of heavily limed and oxygenated water being heated. This is harmless and the cause is the water and not the heater.
- 6) No water at all.
Cause: Valve incorrectly fitted.
Debris in the mains.
Mains water supply turned off.

Spare Parts

MW/EW 10 - MW/EW 15 Unvented Water Heaters

Cat. No.	Part Description
97783201	3kW Element Assembly
97783240	Control Panel
97783228	MW/EW Anode 155mm Long
97783241	MW/EW Anode 215mm Long
97783204	Temperature Relief Valve HT55
93793710	1/4" Turn Tap
97783208	Line Strainer*
97783210	Service Valve
97783251	1/2" Single Check Valve*
97783206	2l Expansion Vessel Z200*
97783252	1/2" Pressure Reducing Valve*
97783236	Tundish 1/2" male 1/2" female

*Components supplied in Cold Water Control Kit Cat. No. 87-783101

WARNING: Use only genuine Redring spare parts.

Guarantee

We, Applied Energy Products Ltd., guarantee that should this unvented water heater prove to be defective by reason of faulty workmanship or material within 12 months of the date of purchase or commencement of hire we will replace the defective parts FREE OF CHARGE on condition that:-

- a) The appliance has been correctly installed and used only on the supply circuit or voltage stamped on the rating plate
- b) The appliance has been used in accordance with these instructions and has not been tampered with or otherwise subject to misuse, neglect or accident.
- c) The appliance has not been taken apart, modified or repaired except by a person authorised by us.
- d) Evidence of the date of purchase in the form of an invoice, receipt (hire purchase documents) is included with the appliance if returned under guarantee.

“This guarantee does not affect your Statutory rights”

Full details of Terms and Conditions are available on request from:-

REDRING®

APPLIED ENERGY PRODUCTS LTD., MORLEY WAY, PETERBOROUGH,
PE2 9JJ. TEL: +44 (0)1733 456789 FAX: +44 (0)1733 310606
Website: www.redring.com