



### Main

Range of product	Modicon TM3
Product or component type	Discrete output module
Range compatibility	Modicon M221 Modicon M241 Modicon M251
Discrete output type	Transistor
Discrete output number	16
Discrete output logic	Negative logic (sink)
Discrete output voltage	24 V DC for transistor output
Discrete output current	100 mA for transistor output

### Complementary

Discrete I/O number	16
Current consumption	20 mA at 24 V DC via bus connector at state on 15 mA at 5 V DC via bus connector at state on 0 mA at 24 V DC via bus connector at state off 5 mA at 5 V DC via bus connector at state off
Response time	450 µs for turn-off 450 µs for turn-on
Leakage current	0.1 mA for transistor output
Voltage drop	0.4 V
Local signalling	1 LED per channel green for output status
Electrical connection	HE-10 connector for outputs
Cable length	<= 5 m unshielded cable cable for transistor output
Insulation	Non-insulated between outputs 500 V AC between output and internal logic
Marking	CE
Mounting support	Plate or panel with fixing kit Top hat type TH35-7.5 rail conforming to IEC 60715 Top hat type TH35-15 rail conforming to IEC 60715
Height	70 mm
Depth	84.6 mm
Width	27.3 mm
Product weight	0.111 kg

### Environment

Standards	EN/IEC 61131-2 EN/IEC 61010-2-201
Product certifications	C-Tick CULus
Resistance to electrostatic discharge	On contact - EN/IEC 61000-4-2 In air - EN/IEC 61000-4-2
Resistance to electromagnetic fields	1 V/m (2 GHz...3 GHz) - EN/IEC 61000-4-3 3 V/m (1.4 GHz...2 GHz) - EN/IEC 61000-4-3 10 V/m (80 MHz...1 GHz) - EN/IEC 61000-4-3
Resistance to magnetic fields	30 A/m (50...60 Hz) - EN/IEC 61000-4-8
Resistance to fast transients	1 kV for I/O - EN/IEC 61000-4-4
Surge withstand	1 kV for I/O (DC) in common mode - EN/IEC 61000-4-5
Resistance to conducted disturbances, induced by radio frequency fields	3 Vrms (spot frequency (2, 3, 4, 6.2, 8.2, 12.6, 16.5, 18.8, 22, 25 MHz)) - Marine specification (LR, ABS, DNV, GL) 10 Vrms (0.15...80 MHz) - EN/IEC 61000-4-6

Electromagnetic emission	Radiated emissions - EN/IEC 55011 class A 10 m, 230 MHz...1 GHz : 47 dB $\mu$ V/m QP Radiated emissions - EN/IEC 55011 class A 10 m, 30...230 MHz : 40 dB $\mu$ V/m QP
Ambient air temperature for operation	-10...55 °C for horizontal installation -10...35 °C for vertical installation
Ambient air temperature for storage	-25...70 °C
Relative humidity	10...95 % without condensation in storage 10...95 % without condensation in operation
IP degree of protection	IP20 with protective cover in place
Pollution degree	2
Operating altitude	0...2000 m
Storage altitude	0...3000 m
Vibration resistance	3 gn (vibration frequency: 8.4...150 Hz) on panel 3.5 mm (vibration frequency: 5...8.4 Hz) on panel 3 gn (vibration frequency: 8.4...150 Hz) on DIN rail 3.5 mm (vibration frequency: 5...8.4 Hz) on DIN rail
Shock resistance	15 gn (test wave duration:11 ms)

Dimensions

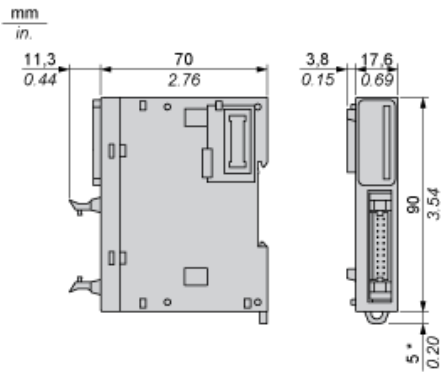

(\*) 8.5 mm/0.33 in. when the clamp is pulled out.

Spacing Requirements

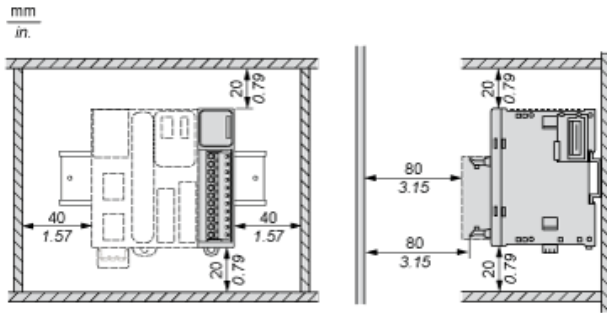

Mounting on a Rail

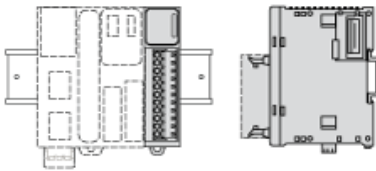

Incorrect Mounting

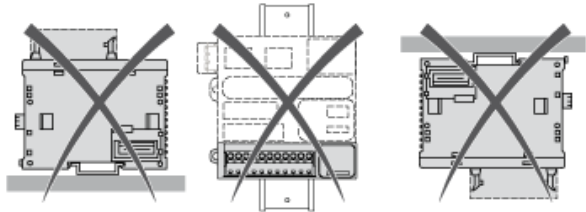

Mounting on a Panel Surface

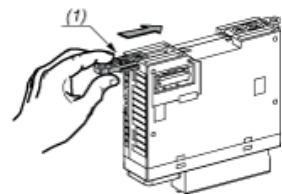

(1) Install a mounting strip

Mounting Hole Layout

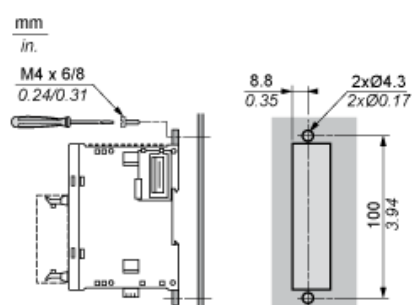

Digital Transistor Output Module (16-channel, Sink)

Wiring Diagram

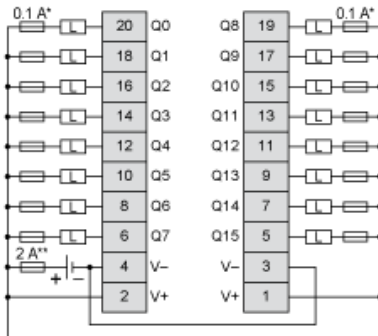

- (\*) Type T Fuse
- (\*\*) Type F fuse