



Main

Range of product	Modicon TM3
Product or component type	Discrete input module
Range compatibility	Modicon M221 Modicon M241 Modicon M251
Discrete input number	16 input conforming to IEC 61131-2 type 3
Discrete input logic	Sink or source (positive/negative)
Discrete input voltage	24 V
Discrete input current	5 mA for input

Complementary

Discrete I/O number	16
Current consumption	35 mA at 5 V DC via bus connector at state on 0 mA at 24 V DC via bus connector at state off 0 mA at 24 V DC via bus connector at state on 5 mA at 5 V DC via bus connector at state off
Discrete input voltage type	DC
Voltage state 1 guaranteed	15...28.8 V for input
Current state 1 guaranteed	≥ 2.5 mA for input
Voltage state 0 guaranteed	0...5 V for input
Current state 0 guaranteed	≤ 1 mA for input
Input impedance	4.4 kOhm
Response time	4 ms for turn-off 4 ms for turn-on
Local signalling	1 LED per channel green for input status
Electrical connection	HE-10 connector for inputs
Cable length	≤ 50 m unshielded cable for regular input
Insulation	Non-insulated between inputs 500 V AC between input and internal logic
Marking	CE
Mounting support	Plate or panel with fixing kit Top hat type TH35-7.5 rail conforming to IEC 60715 Top hat type TH35-15 rail conforming to IEC 60715
Height	70 mm
Depth	84.6 mm
Width	27.3 mm
Product weight	0.65 kg

Environment

Standards	EN/IEC 61131-2 EN/IEC 61010-2-201
Product certifications	C-Tick CULus
Resistance to electrostatic discharge	On contact - EN/IEC 61000-4-2 In air - EN/IEC 61000-4-2
Resistance to electromagnetic fields	1 V/m (2 GHz...3 GHz) - EN/IEC 61000-4-3 3 V/m (1.4 GHz...2 GHz) - EN/IEC 61000-4-3 10 V/m (80 MHz...1 GHz) - EN/IEC 61000-4-3
Resistance to magnetic fields	30 A/m (50...60 Hz) - EN/IEC 61000-4-8

Resistance to fast transients	1 kV for I/O - EN/IEC 61000-4-4
Surge withstand	1 kV for I/O (DC) in common mode - EN/IEC 61000-4-5
Resistance to conducted disturbances, induced by radio frequency fields	3 Vrms (spot frequency (2, 3, 4, 6.2, 8.2, 12.6, 16.5, 18.8, 22, 25 MHz)) - Marine specification (LR, ABS, DNV, GL) 10 Vrms (0.15...80 MHz) - EN/IEC 61000-4-6
Electromagnetic emission	Radiated emissions - EN/IEC 55011 class A 10 m, 230 MHz...1 GHz : 47 dB μ V/m QP Radiated emissions - EN/IEC 55011 class A 10 m, 30...230 MHz : 40 dB μ V/m QP
Ambient air temperature for operation	-10...55 °C for horizontal installation -10...35 °C for vertical installation
Ambient air temperature for storage	-25...70 °C
Relative humidity	10...95 % without condensation in storage 10...95 % without condensation in operation
IP degree of protection	IP20 with protective cover in place
Pollution degree	2
Operating altitude	0...2000 m
Storage altitude	0...3000 m
Vibration resistance	3 gn (vibration frequency: 8.4...150 Hz) on panel 3.5 mm (vibration frequency: 5...8.4 Hz) on panel 3 gn (vibration frequency: 8.4...150 Hz) on DIN rail 3.5 mm (vibration frequency: 5...8.4 Hz) on DIN rail
Shock resistance	15 gn (test wave duration:11 ms)

Dimensions

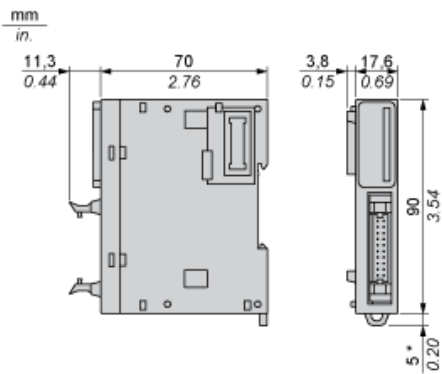

(*) 8.5 mm/0.33 in. when the clamp is pulled out.

Spacing Requirements

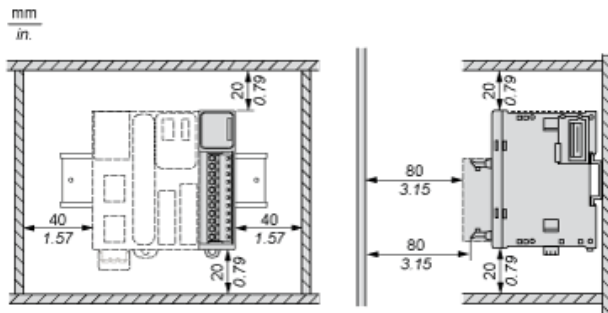

Mounting on a Rail

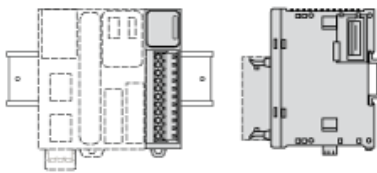

Incorrect Mounting

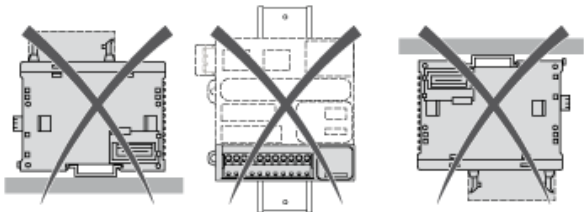

Mounting on a Panel Surface

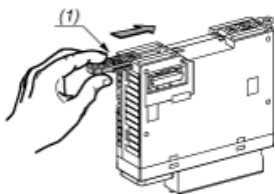

(1) Install a mounting strip

Mounting Hole Layout

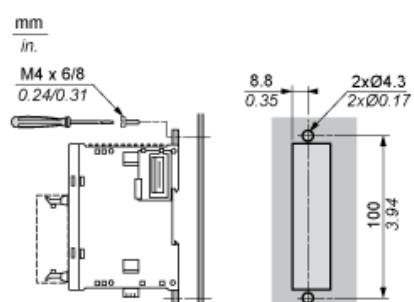

Digital Input Module (16-channel, 24 Vdc)

Wiring Diagrams

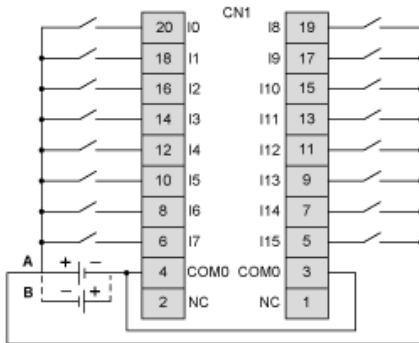

The COM0 terminals are connected internally

- (A) Sink wiring (positive logic)
- (B) Source wiring (negative logic)