

LMX2492 Evaluation Instructions Ultra Low Noise Frequency Synthesizer with Integrated VCO Evaluation Board Operating Instructions

User's Guide



Literature Number: SNAU160A
March 2014–Revised May 2014

1	Evaluation Board Setup	4
1.1	Evaluation Board Setup Diagram and Connections.....	4
1.1.1	VCO Outputs	4
1.1.2	VCC 5V	4
1.1.3	VCC 3P3V	4
1.1.4	USB2ANY Connector	4
1.1.5	OSCin/OSCin*.....	4
2	Evaluation Board Configuration	5
2.1	Loop Filter Configuration.....	5
2.2	CodeLoader Software Settings	6
2.2.1	Port Setup	6
2.2.2	Device Selection	7
2.2.3	Bits/Pins Tab and Restoring the Default Configuration	8
2.2.4	Registers Tab	9
2.2.5	PLL Frequency Tab	10
2.2.6	Ramp Generator Tab	11
3	Schematic	12
4	Board Layers Stackup.....	13
5	Bill of Materials	14
6	Typical Performance Measurements	16
6.1	PLL Phase Noise	16
6.2	Ramping Example.....	19
	Revision History.....	20

Evaluation Board Operating Instructions

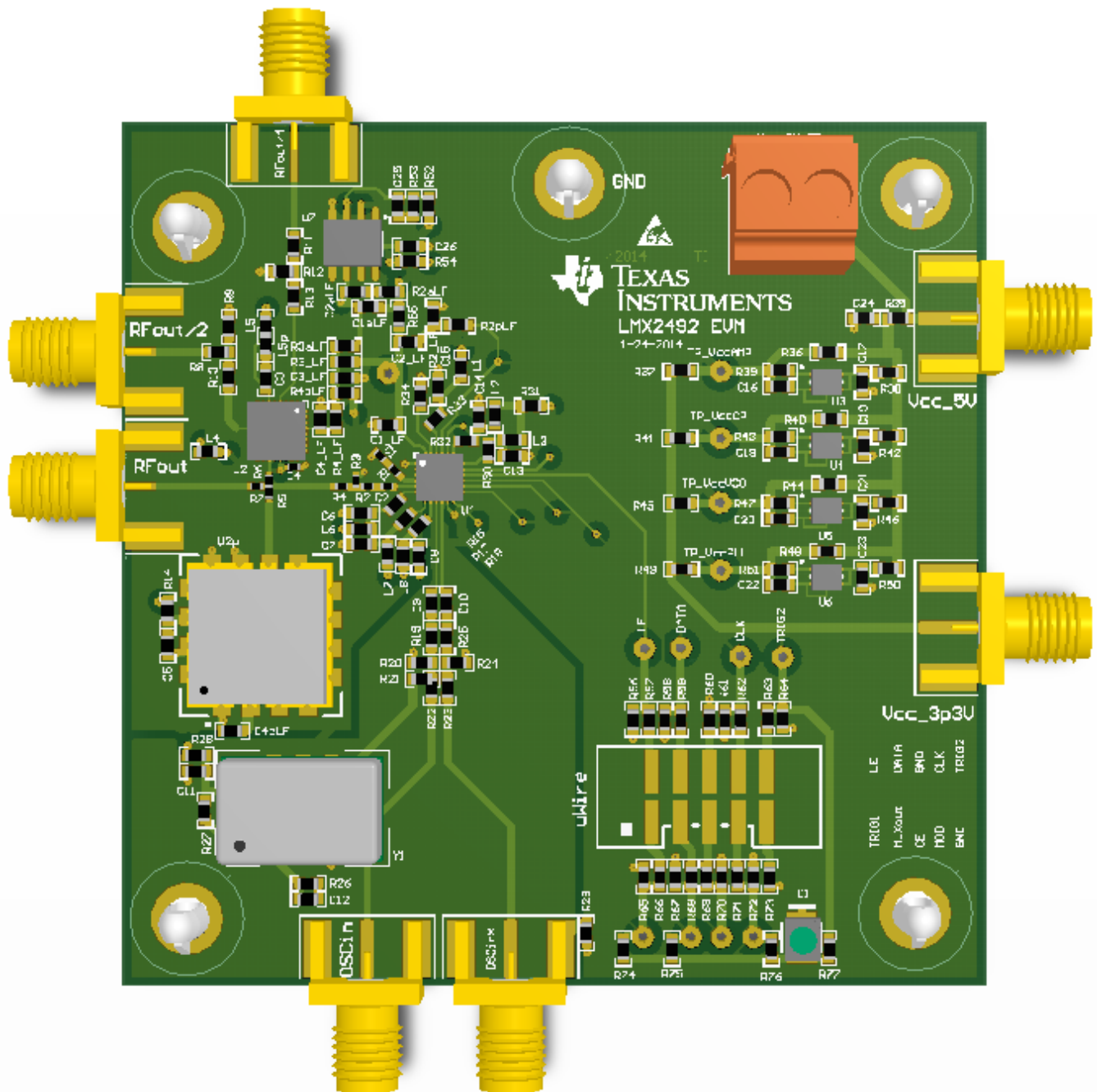

Evaluation Board Setup

1.1 Evaluation Board Setup Diagram and Connections

Figure 1-1. Evaluation Board Connection Diagram

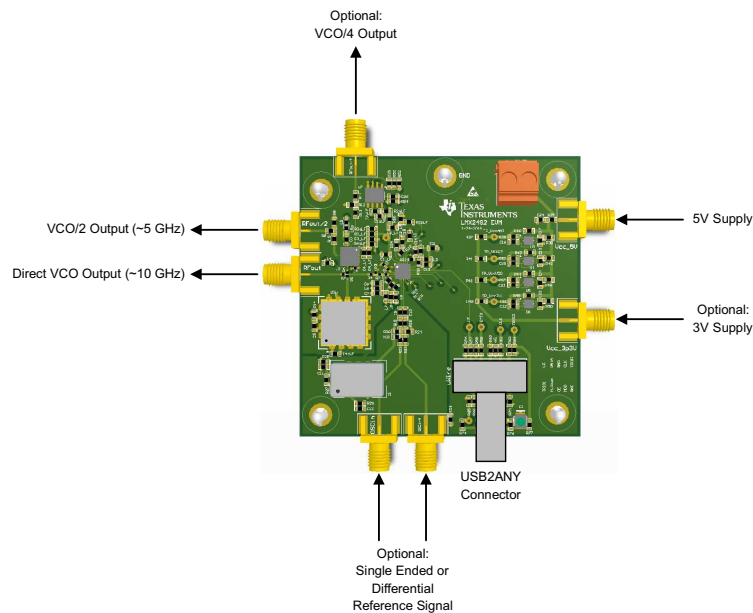

1.1.1 VCO Outputs

The LMX2492 operates at 10 GHz, but this can be a problem for some test equipment. If it is, use the VCO/2 output or the VCO/4 output. The VCO/4 output is powered down by default, but can be configured if necessary.

1.1.2 VCC 5V

The board operates on 5V and regulates this down to 3.3 V for the PLL. The board can be configured to operate with separate

1.1.3 VCC 3P3V

This is actually supplied from the regular off the 5V supply, but can also be run from a 3.3 V supply if the regulator is disconnected and a few resistors are changed.

1.1.4 USB2ANY Connector

Connect the board to the computer using the USB2ANY connector.

1.1.5 OSCin/OSCin*

The board has an on board XO, but the OSCin pins can be run either single-ended or differentially.

Evaluation Board Configuration

2.1 Loop Filter Configuration

Table 2-1. Loop Filter Values

PARAMETER	LMX2492
VCO Frequency	9.4 – 10.1 GHz
VCO Gain (MHz/V)	200 MHz/V
C1_LF	68 pF
C2_LF	3.9 nF
C3_LF	150 pF
C4_LF	Open
R2	390 Ω
R3_LF	150 Ω
R4_LF	0 Ω
Charge Pump Gain	3.1 mA
Phase Detector Frequency	100 MHz
OSCin Frequency	100 MHz

2.2 CodeLoader Software Settings

The CodeLoader software is used for programming this device and is available at www.ti.com/codeloader.

2.2.1 Port Setup

The port setup shows which pins are sent to the pins of the header. If using the USB2ANY board, it is recommended to click the "Identify" button and ensure the LED light is blinking to ensure that this is working correctly. Note that position 3 is MUXout, which can be used for readback. In order to do this, the MUXout pin needs to be programmed to Readback and also resistor R68 needs to be placed.

Figure 2-1. LMX2492 Port Setup

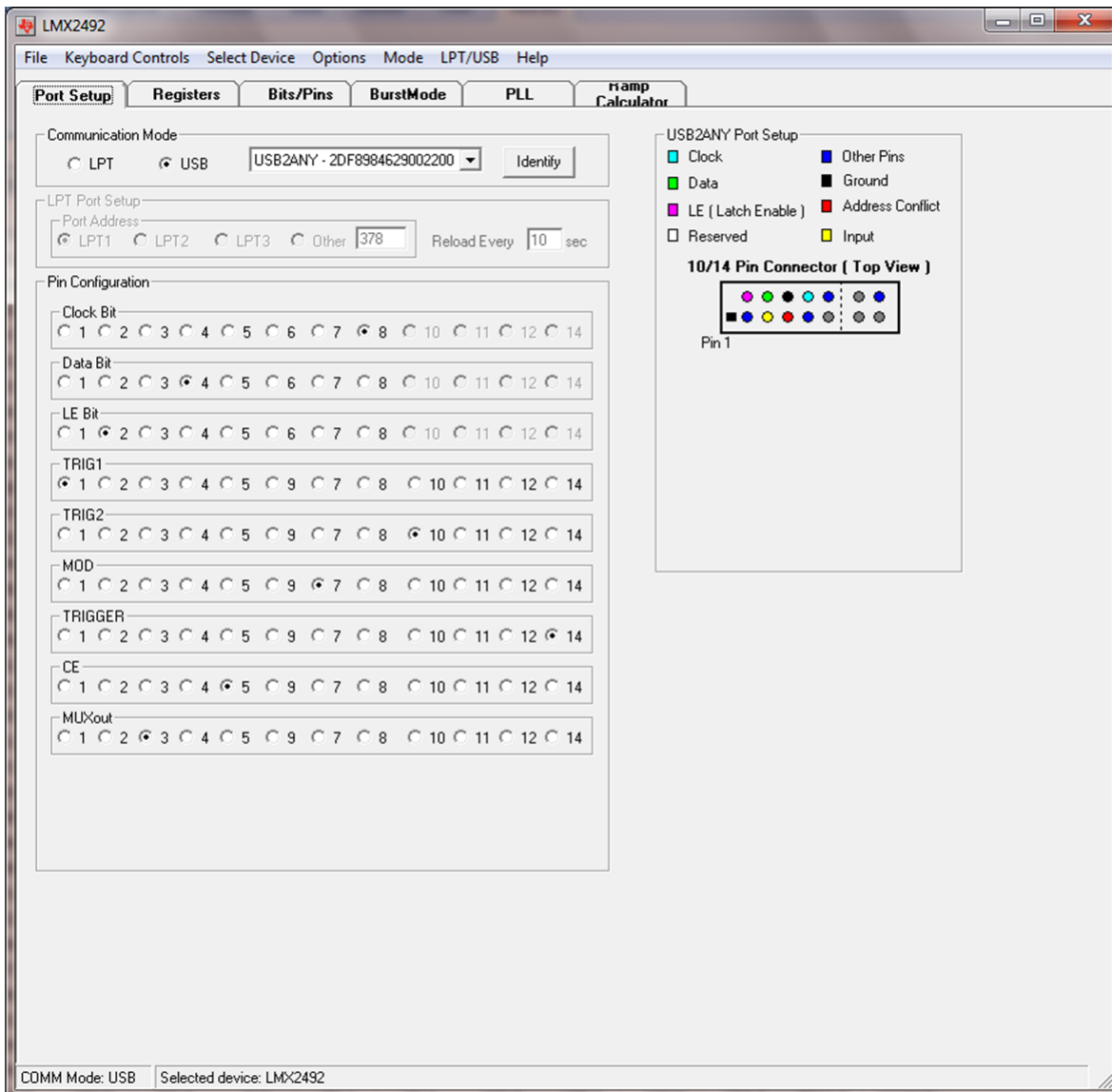

2.2.2 Device Selection

Go to “Select Device” → “PLL–Fractional” → LMX2492

Figure 2-2. Part Selection

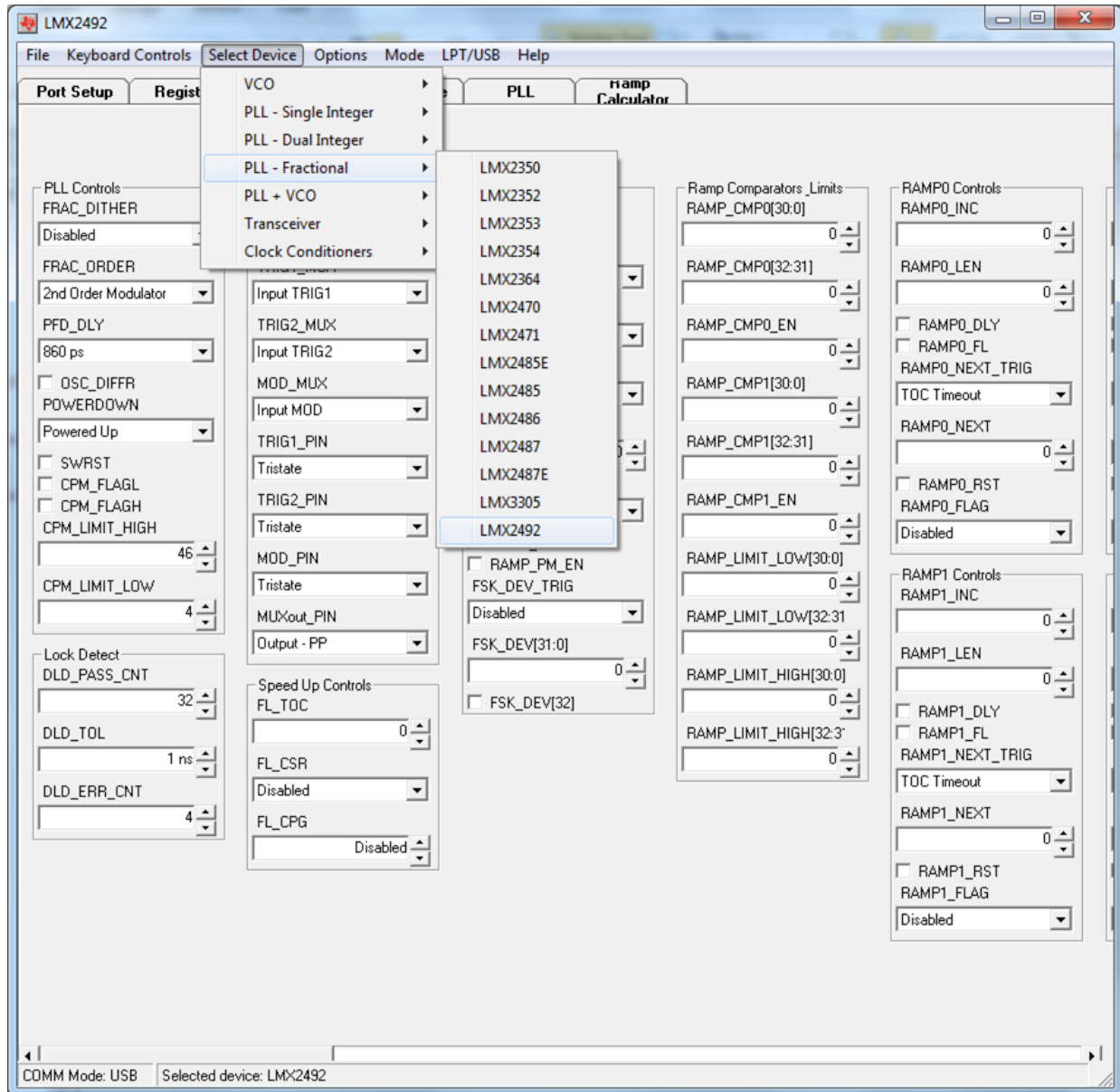

2.2.3 Bits/Pins Tab and Restoring the Default Configuration

The Bits/Pins tab shows the state of the programming fields. Note the scroll bar at the bottom. One can right mouse click on any field for a short description of what it does. To restore the part to the original software configuration, one can select the default mode as shown.

Figure 2-3. Restoring Default Mode

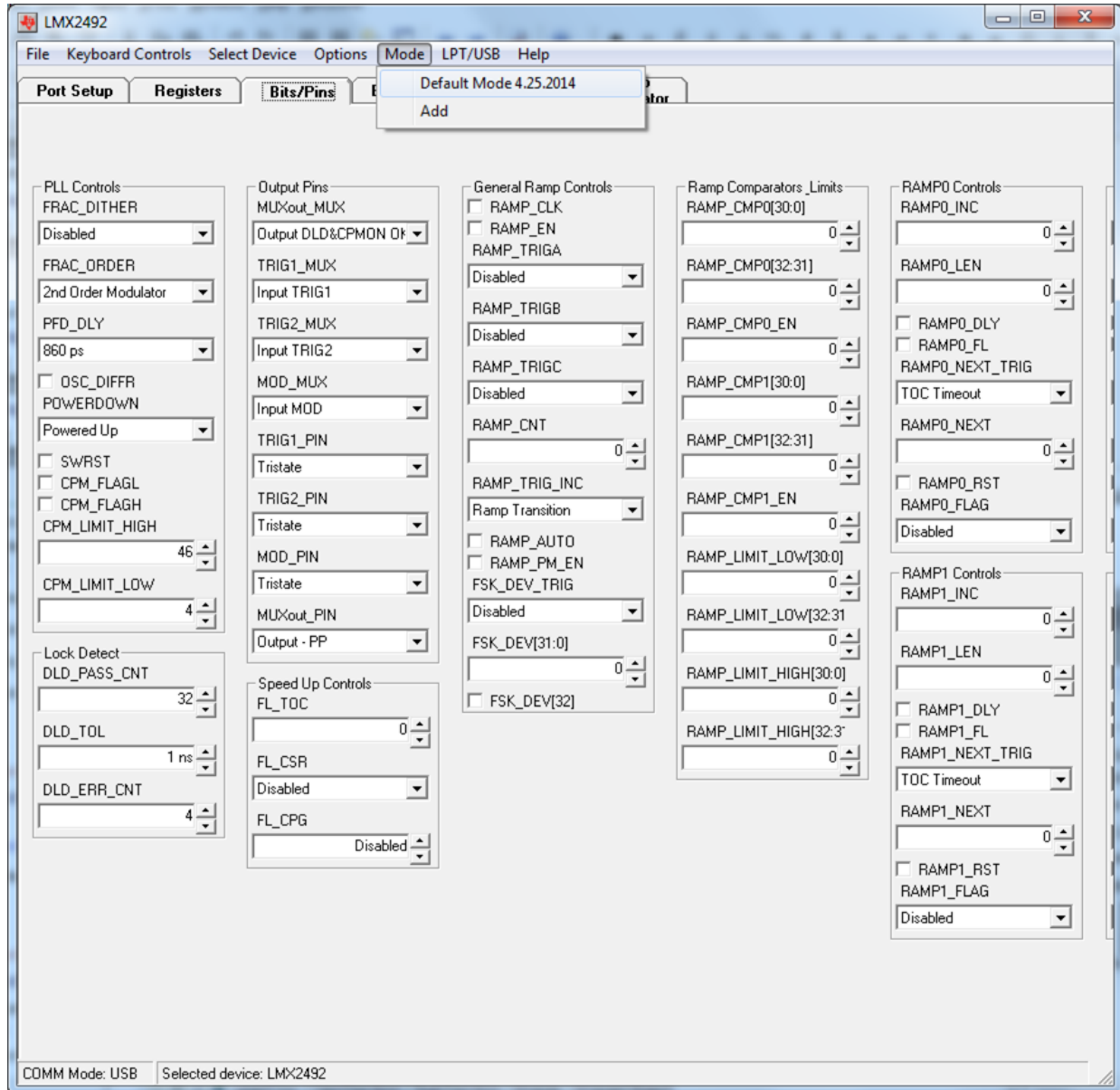

2.2.4 Registers Tab

The registers tab is not necessary to program the part, but it does show the registers. The LMX2492 also supports readback. To use this, set the MUXout pin to readback and attach resistor R68 to connect this pin back to the programming header. Once this is done entire registers can be read, or a specific field can be typed in to read the value. Realize that some fields of the LMX2492 are read only and therefore might not be the same as written to.

Figure 2-4. Registers Tab

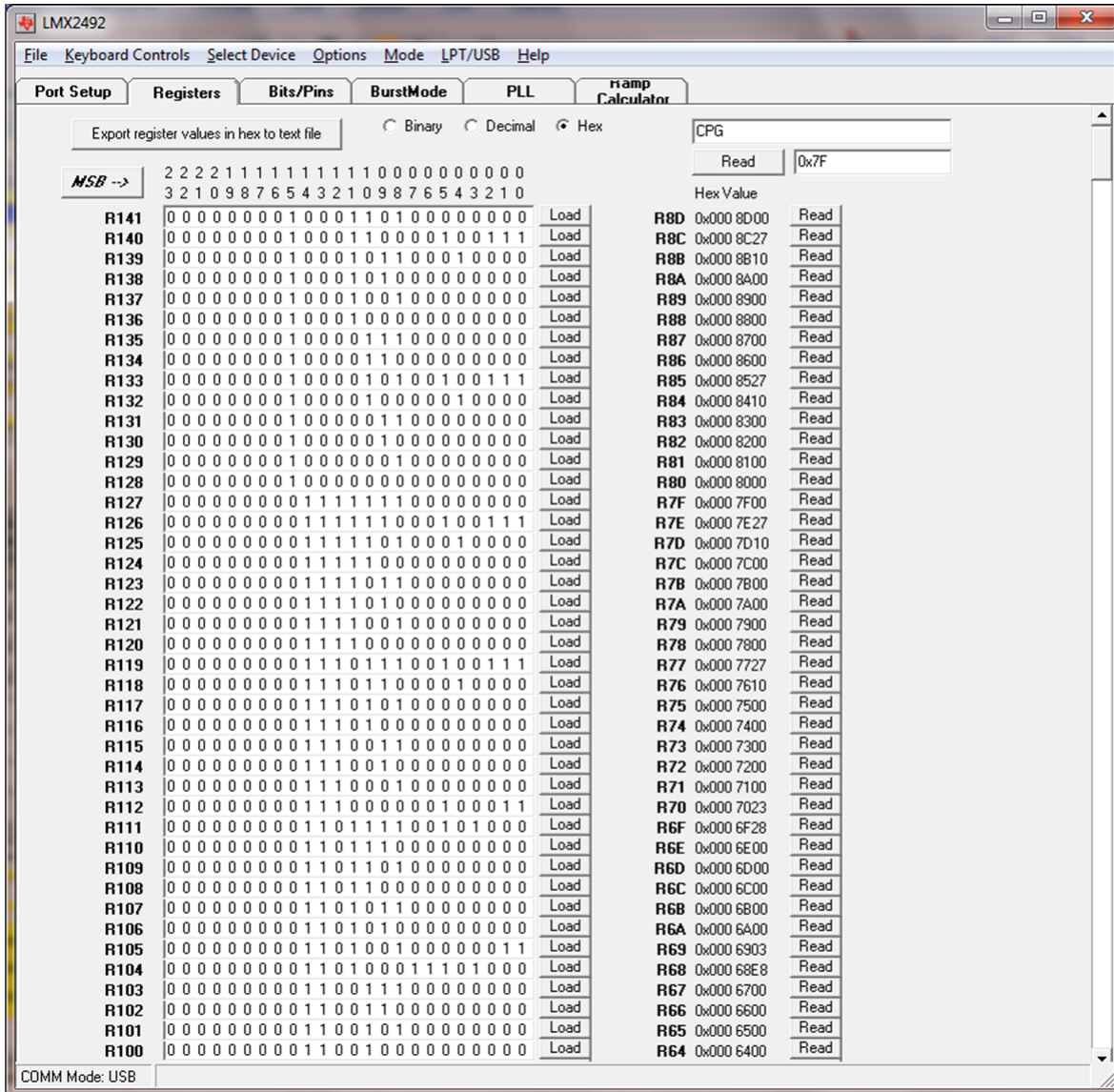

2.2.5 PLL Frequency Tab

Verify your “PLL” Tab looks like below:

Figure 2-5. PLL Frequency Tab

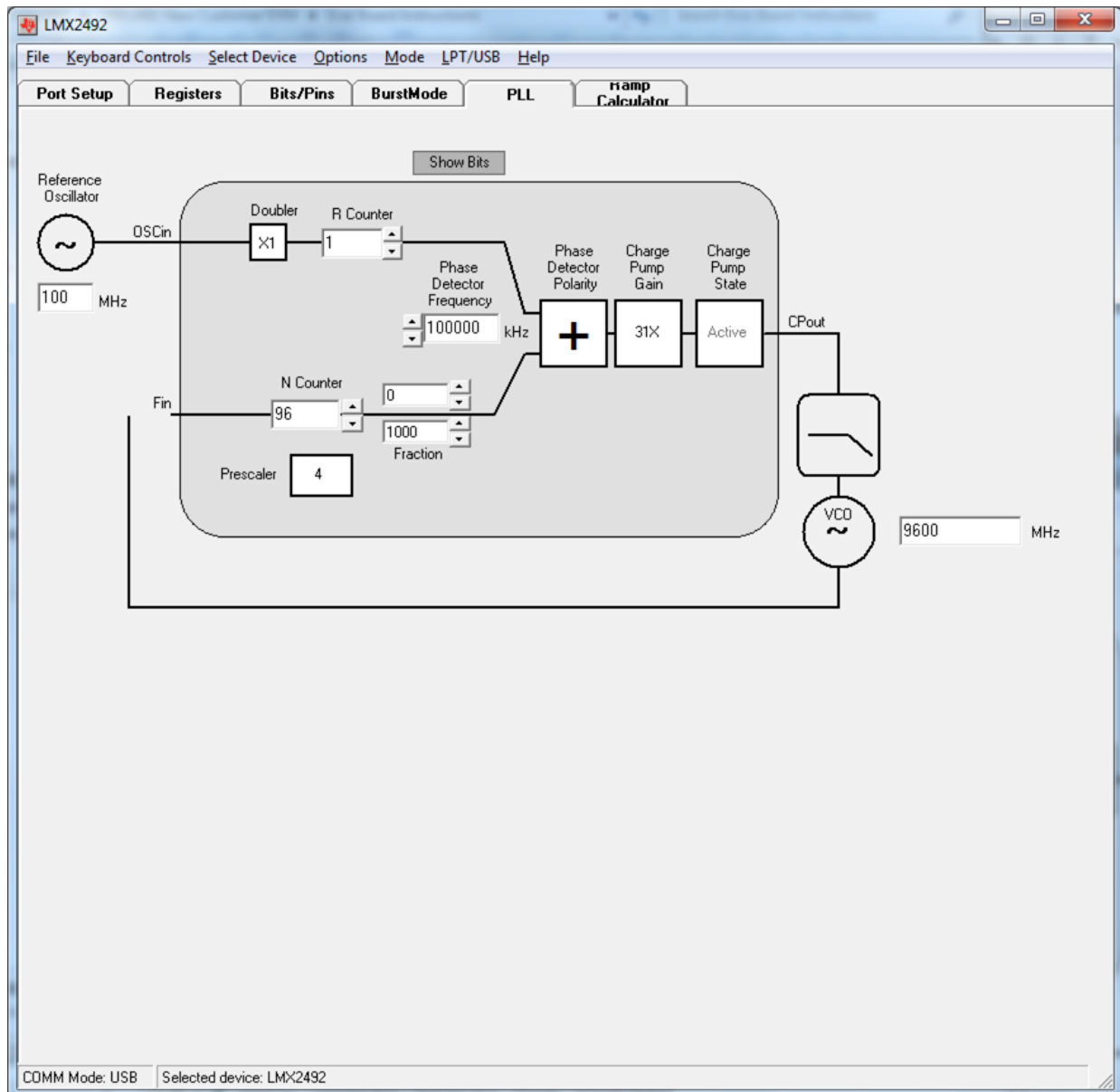

2.2.6 Ramp Generator Tab

Verify your “Ramp Calculator” Tab looks like below. If not using the ramping features, or when just getting the device up and running, it is advised not to Enable the Flex Scripts as they slow the software down. Once the part is running, then enable the flex scripts as shown below and calculations the Ramp Generator Tab will become active.

Figure 2-6. Enabling the Flex Scripts for the Ramp Generator GUI

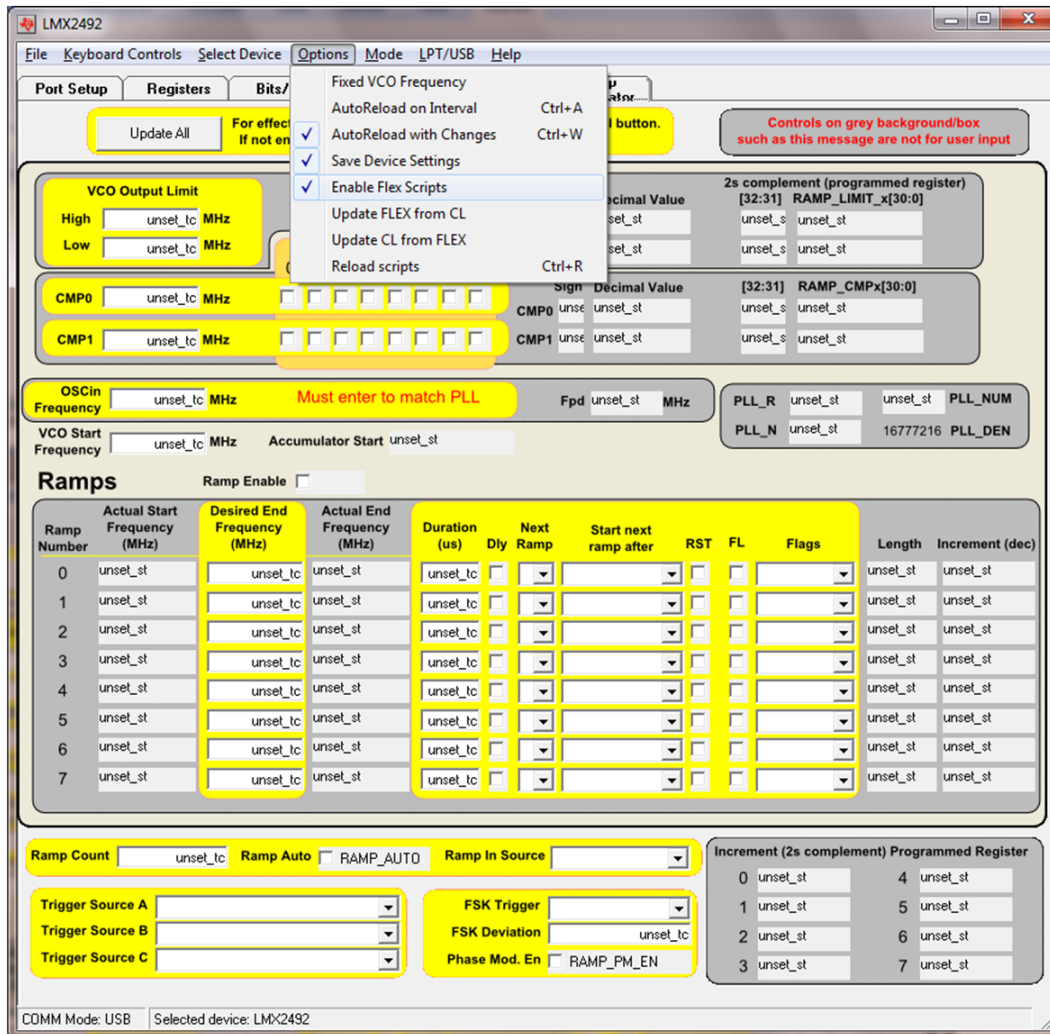

Then Click on “Update All” and wait until you see your screen populate to below:

Notes for Ramp Calculator tab:

- Manually change the OSCin Frequency in the “Ramp Calculator” tab when you change the value in the “PLL” tab
- Click “Update All” whenever you change values in the frequency section
- Only modify values in "Yellow" regions
- Click and unclick “RST” to clear the accumulator after modifying a row in Ramps

Schematic

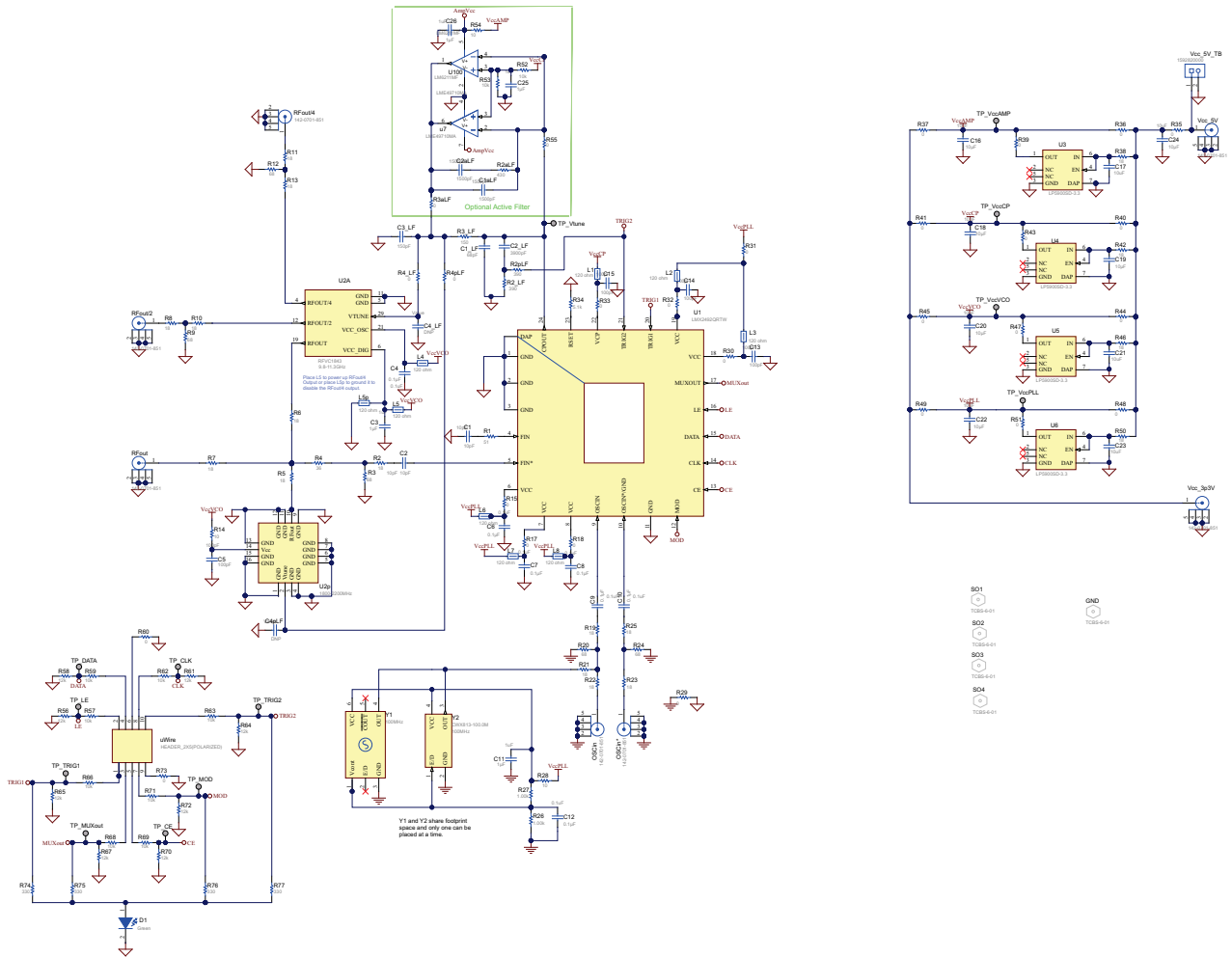

Board Layers Stackup

Layers of the 4 layer evaluation board shall include: Blue is dielectrics

- Top layer for high priority high frequency signals (GTL)
 - 1 oz CU
- RO4003 Dielectric, 16 mils
- Ground plane (GP1)
- FR4, 18 mils thick.
- Power plane – VccCLK (GP2)
- FR4, 22 mils
- Bottom layer copper clad for thermal relief (GBL)

Table 4-1. Top to Bottom Layer Order:

LMX2492.GTL	(1)	Top Layer
LMX2492.GP1	(2)	GND Plane
LMX2492.G1	(3)	Power
LMX2492.GBL	(4)	Bottom Layer

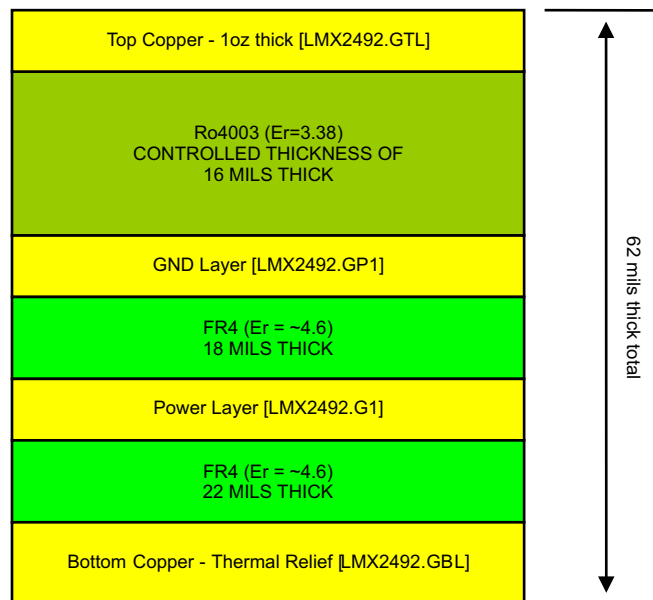

Figure 4-1. Board Layers Stackup

Bill of Materials

ITEM	DESIGNATOR	DESCRIPTION	RoHS	MANUFACTURER	PART NUMBER	QTY
1	AA1	Printed Circuit Board	O	TBD	Used in BOM Report	1
2	C1, C2	CAP, CERM, 10pF, 50V, +/-5%, COG/NP0, 0402	Y	Johanson Technology	500R07S100JV4T	2
3	C1_LF	CAP, CERM, 68pF, 50V, +/-5%, COG/NP0, 0603	Y	Kemet	C0603C680J5GACTU	1
4	C2_LF	CAP, CERM, 3900pF, 50V, +/-5%, COG/NP0, 0603	Y	MuRata	GRM1885C1H392JA01D	1
5	C3, C11	CAP, CERM, 1uF, 16V, +/-10%, X7R, 0603	Y	TDK	C1608X7R1C105K	2
6	C3_LF	CAP, CERM, 150pF, 50V, +/-5%, COG/NP0, 0603	Y	Kemet	C0603C151J5GACTU	1
7	C4	CAP, CERM, 0.1uF, 50V, +/-10%, COG/NP0, 0402	Y	TDK	C1005X7R1H104K	1
8	C5, C13, C14, C15	CAP, CERM, 100pF, 50V, +/-5%, COG/NP0, 0603	Y	Kemet	C0603C101J5GACTU	4
9	C6, C7, C8, C9, C10	CAP, CERM, 0.1uF, 16V, +/-5%, X7R, 0603	Y	AVX	0603YC104JAT2A	5
10	C16, C18, C20, C22, C23, C24	CAP, CERM, 10uF, 6.3V, +/-20%, X5R, 0603	Y	Kemet	C0603C106M9PACTU	6
11	D1	LED, Green, SMD	Y	Lumex	SML-LX2832GC-TR	1
12	L1, L2, L3, L4, L5p, L6, L7, L8	3A Ferrite Bead, 120 ohm @ 100MHz, SMD	Y	MuRata	BLM18SG121TN1D	8
13	OSCin, RFout, RFout/2, Vcc_5V	Connector, SMT, End launch SMA 50 ohm	Y	Emerson	142-0701-851	4
14	R1	RES, 51 ohm, 5%, 0.063W, 0402	Y	Vishay-Dale	CRCW040251R0JNED	1
15	R2, R6, R7	RES, 18 ohm, 5%, 0.063W, 0402	Y	Vishay-Dale	CRCW040218R0JNED	3
16	R2_LF	RES, 390 ohm, 5%, 0.1W, 0603	Y	Vishay-Dale	CRCW0603390RJNEA	1
17	R3	RES, 68 ohm, 5%, 0.063W, 0402	Y	Vishay-Dale	CRCW040268R0JNED	1
18	R3_LF	RES, 150 ohm, 5%, 0.1W, 0603	Y	Vishay-Dale	CRCW0603150RJNEA	1
19	R4	RES, 36 ohm, 5%, 0.063W, 0402	Y	Vishay-Dale	CRCW040236R0JNED	1
20	R4_LF, R15, R17, R18, R29, R30, R31, R32, R33, R35, R40, R44, R49, R51, R60	RES, 0 ohm, 5%, 0.1W, 0603	Y	Vishay-Dale	CRCW06030000Z0EA	15
21	R8, R10, R11, R13, R19, R22, R23, R25, R50	RES, 18 ohm, 5%, 0.1W, 0603	Y	Vishay-Dale	CRCW060318R0JNEA	9
22	R9, R12, R20, R24	RES, 68 ohm, 5%, 0.1W, 0603	Y	Vishay-Dale	CRCW060368R0JNEA	4
23	R14	RES, 10 ohm, 5%, 0.1W, 0603	Y	Vishay-Dale	CRCW060310R0JNEA	1
24	R56, R58, R61, R64, R65, R70, R72	RES, 12k ohm, 5%, 0.1W, 0603	Y	Vishay-Dale	CRCW060312K0JNEA	7

ITEM	DESIGNATOR	DESCRIPTION	RoHS	MANUFACTURER	PART NUMBER	QTY
25	R57, R59, R62, R63, R66, R69, R71	RES, 10k ohm, 5%, 0.1W, 0603	Y	Vishay-Dale	CRCW060310K0JNEA	7
26	R75	RES, 330 ohm, 5%, 0.1W, 0603	Y	Yageo America	RC0603JR-07330RL	1
27	SO1, SO2, SO3, SO4	HEX STANDOFF SPACER, 9.53 mm	Y	Richco Plastics	TCBS-6-01	4
28	U1	13.5 GHz Low Phase Noise Fractional N PLL with Ramp/Chirp Generation, RTW0024A	Y	Texas Instruments	LMX2492QRTW	1
29	U2	VCO, 9.8-11.3GHz, SMD	Y	RF Micro Devices	RFVC1843	1
30	U6	Ultra Low Noise, 150mA Linear Regulator for RF/Analog Circuits Requires No Bypass Capacitor, 6-pin LLP	N	Texas Instruments	LP5900SD-3.3	1
31	uWire	Connector		FCI	52601-G10-8LF	1
32	Y2	OSC 100.0000MHZ 3.3V +- 25PPM SMD	Y	Connor-Winfield	CWX813-100.0M	1

Typical Performance Measurements

6.1 PLL Phase Noise

Figure 6-1. Phase Noise in Default Mode

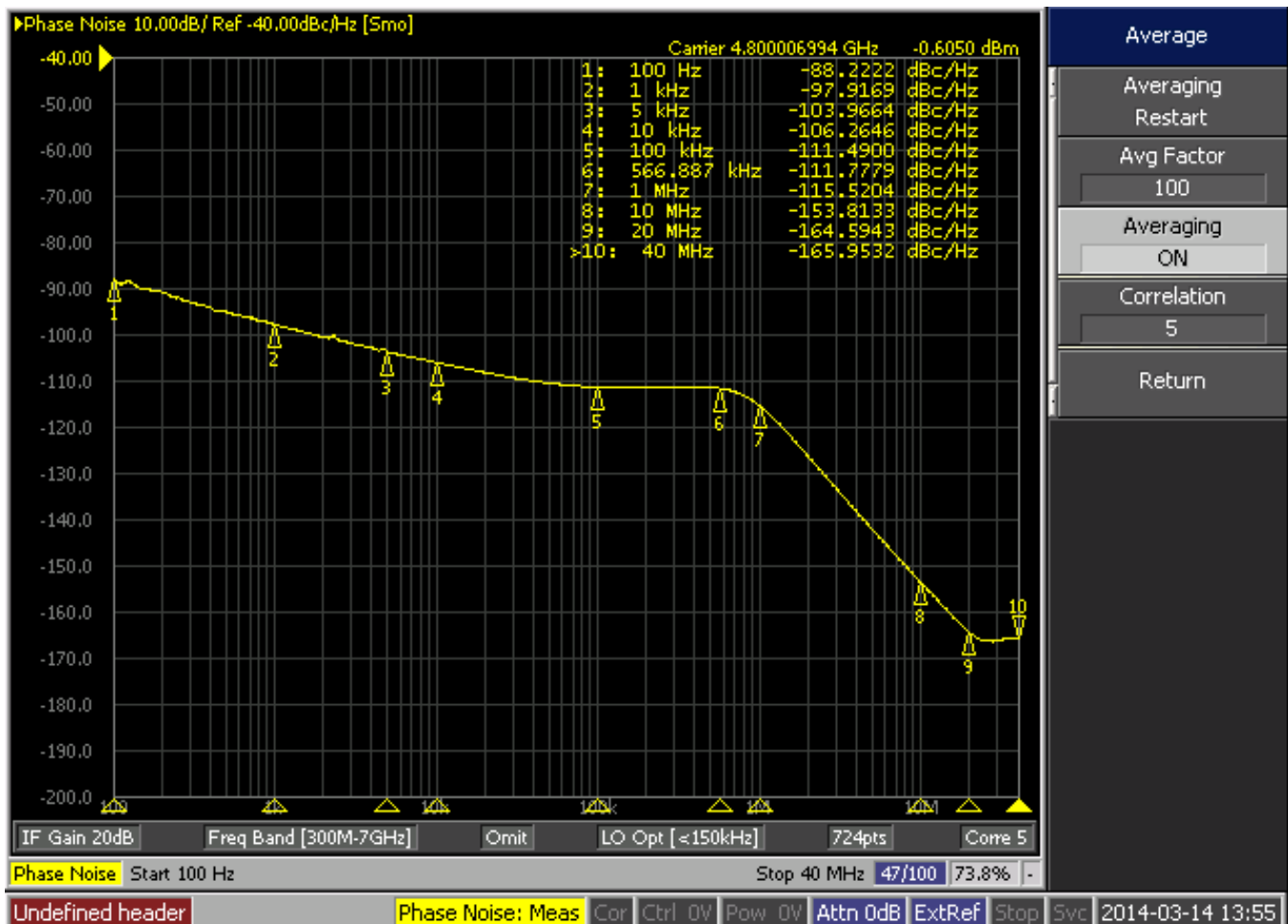

The above figure shows the phase noise in default for mode. Note that this is $\frac{1}{2}$ the VCO frequency as it was observed on the Fout/2 output.

Figure 6-2. Phase Noise with a Wide Loop Bandwidth

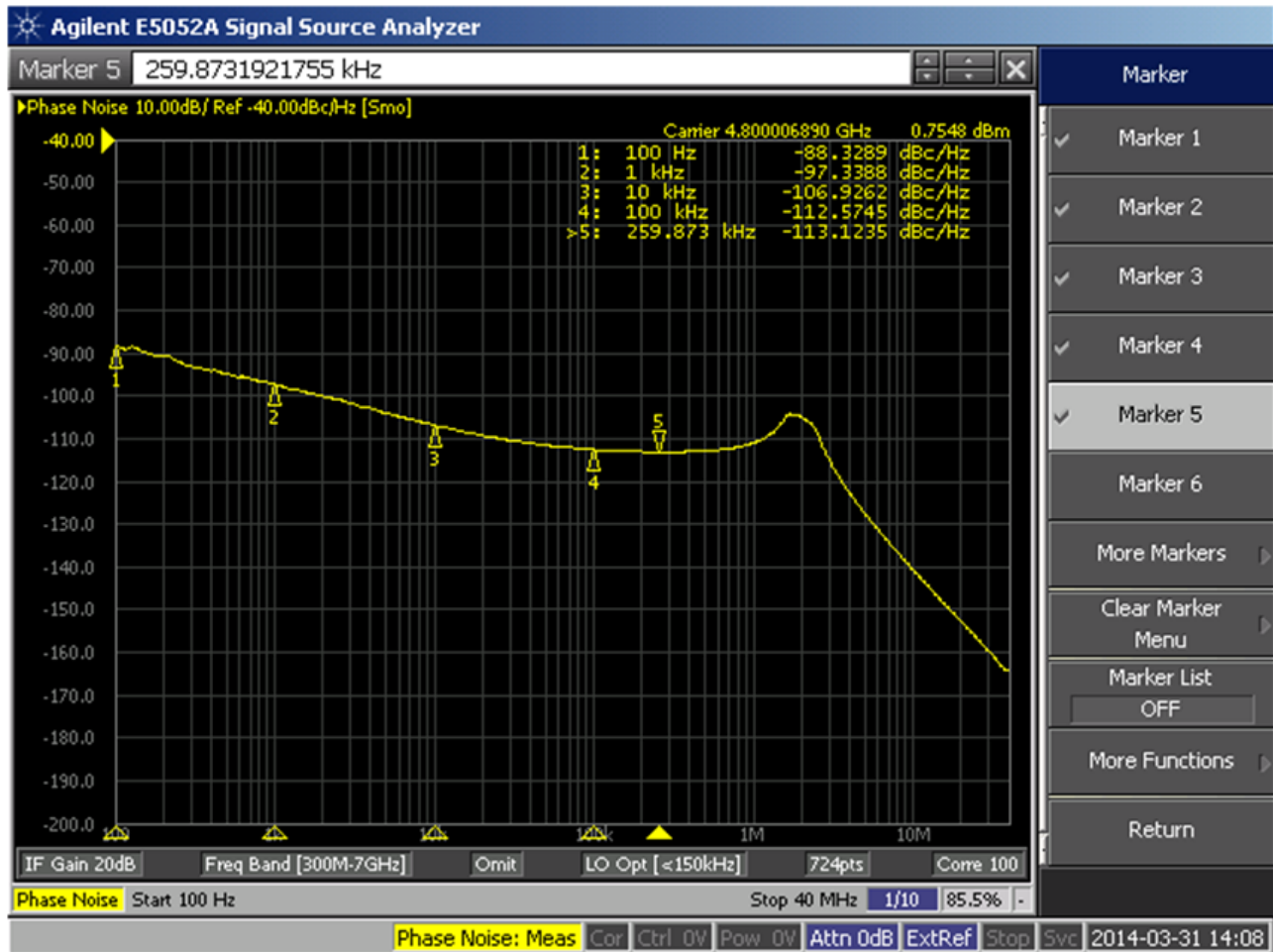

The figure above shows phase noise with a wide loop bandwidth and 100 MHz phase detector frequency. At about 260 kHz, the phase noise is -113.1 dBc/Hz, which is actually being degraded by 0.5 dB by the 1/f noise. This implies a figure of merit of -227.2 dBc/Hz.

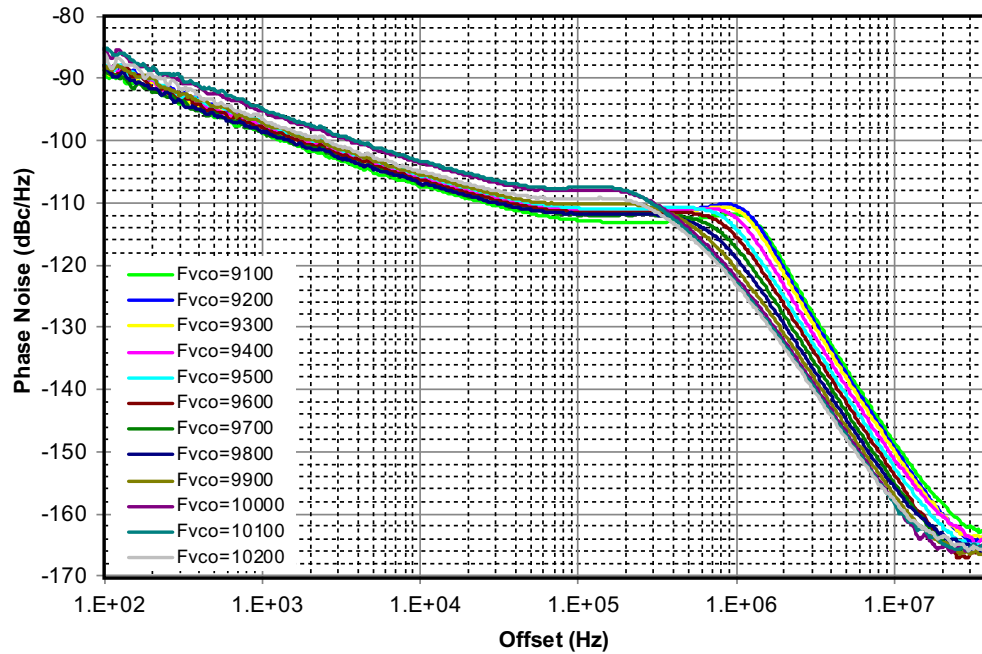
Figure 6-3. Phase Noise vs Tuning Voltage

The phase noise of the LMX2492 does vary somewhat with tuning voltage with the best performance typically near lower tuning voltages.

Table 6-1. Phase Noise

FVCO	Vtune
9000	0.04
9100	0.18
9200	0.338
9300	0.518
9400	0.726
9500	0.973
9600	1.26
9700	1.602
9800	2.014
9900	2.483
10000	3.01
10100	3.562
10200	4.158
10300	4.792

6.2 Ramping Example

Below is an example that can be used to generate the waveform shown later in this document.

Figure 6-4. Setup for Ramping Example

The screenshot shows the LMUX2492 software interface. The 'Ramp Calculator' tab is selected. Key settings include:

- VCO Output Limit:** High = 12000 MHz, Low = 9000 MHz.
- CMP0:** 9800 MHz
- CMP1:** 9400 MHz
- OSCI_n Frequency:** 100 MHz
- VCO Start Frequency:** 9400 MHz
- Ramps Table:**

Ramp Number	Actual Start Frequency (MHz)	Desired End Frequency (MHz)	Actual End Frequency (MHz)	Duration (us)	Dly	Next Ramp	Start next ramp after	RST	FL	Flags	Length	Increment (dec)
0	9400	9400	9400	10	1	TOC Timeout				Flag0	1000	0
1	9400	9800	9800.024652481	90	2	TOC Timeout				Disabled	9000	7457
2	9800.024652481	9800.024652481	9800.024652481	10	3	TOC Timeout				Disabled	1000	0
3	9800.024652481	9400	9400	90	0	TOC Timeout				Disabled	9000	-7457
4	-1	10500	-1	100	0	TOC Timeout				Disabled	10000	0
5	-1	10500	-1	100	0	TOC Timeout				Disabled	10000	0
6	-1	10500	-1	100	0	TOC Timeout				Disabled	10000	0
7	-1	10500	-1	100	0	TOC Timeout				Disabled	10000	0

Figure 6-5. Generated Waveform at VCO/2 Output

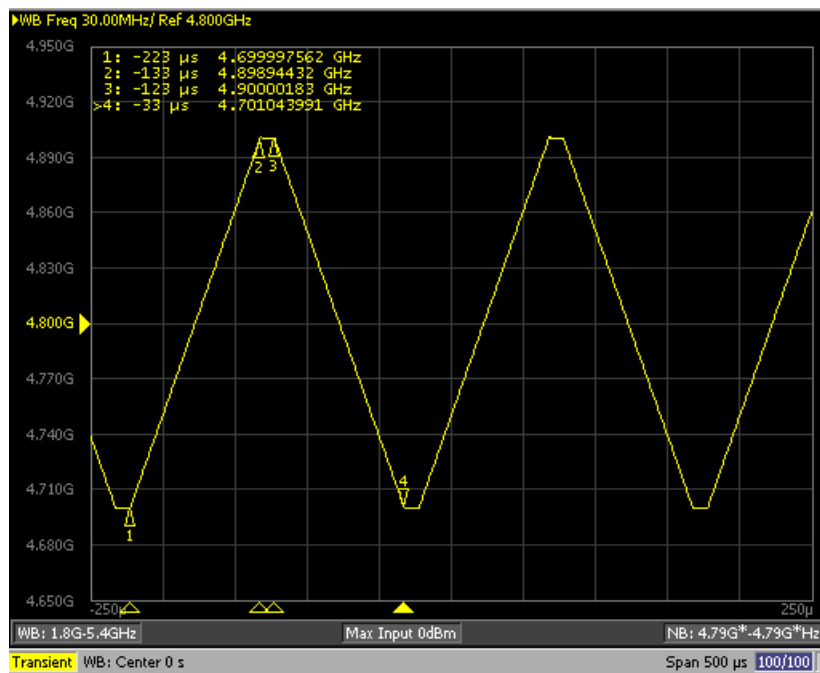

Revision History

Changes from Original (March 2014) to A Revision	Page
• Changed Section Numbering	4
• Changed Loop Filter	5
• Changed CodeLoader Diagrams	6
• Added Ramping Section	11

ADDITIONAL TERMS AND CONDITIONS, WARNINGS, RESTRICTIONS, AND DISCLAIMERS FOR EVALUATION MODULES

Texas Instruments Incorporated (TI) markets, sells, and loans all evaluation boards, kits, and/or modules (EVMs) pursuant to, and user expressly acknowledges, represents, and agrees, and takes sole responsibility and risk with respect to, the following:

1. User agrees and acknowledges that EVMs are intended to be handled and used for feasibility evaluation only in laboratory and/or development environments. Notwithstanding the foregoing, in certain instances, TI makes certain EVMs available to users that do not handle and use EVMs solely for feasibility evaluation only in laboratory and/or development environments, but may use EVMs in a hobbyist environment. All EVMs made available to hobbyist users are FCC certified, as applicable. Hobbyist users acknowledge, agree, and shall comply with all applicable terms, conditions, warnings, and restrictions in this document and are subject to the disclaimer and indemnity provisions included in this document.
2. Unless otherwise indicated, EVMs are not finished products and not intended for consumer use. EVMs are intended solely for use by technically qualified electronics experts who are familiar with the dangers and application risks associated with handling electrical mechanical components, systems, and subsystems.
3. User agrees that EVMs shall not be used as, or incorporated into, all or any part of a finished product.
4. User agrees and acknowledges that certain EVMs may not be designed or manufactured by TI.
5. User must read the user's guide and all other documentation accompanying EVMs, including without limitation any warning or restriction notices, prior to handling and/or using EVMs. Such notices contain important safety information related to, for example, temperatures and voltages. For additional information on TI's environmental and/or safety programs, please visit www.ti.com/esh or contact TI.
6. User assumes all responsibility, obligation, and any corresponding liability for proper and safe handling and use of EVMs.
7. Should any EVM not meet the specifications indicated in the user's guide or other documentation accompanying such EVM, the EVM may be returned to TI within 30 days from the date of delivery for a full refund. THE FOREGOING LIMITED WARRANTY IS THE EXCLUSIVE WARRANTY MADE BY TI TO USER AND IS IN LIEU OF ALL OTHER WARRANTIES, EXPRESSED, IMPLIED, OR STATUTORY, INCLUDING ANY WARRANTY OF MERCHANTABILITY OR FITNESS FOR ANY PARTICULAR PURPOSE. TI SHALL NOT BE LIABLE TO USER FOR ANY INDIRECT, SPECIAL, INCIDENTAL, OR CONSEQUENTIAL DAMAGES RELATED TO THE HANDLING OR USE OF ANY EVM.
8. No license is granted under any patent right or other intellectual property right of TI covering or relating to any machine, process, or combination in which EVMs might be or are used. TI currently deals with a variety of customers, and therefore TI's arrangement with the user is not exclusive. TI assumes no liability for applications assistance, customer product design, software performance, or infringement of patents or services with respect to the handling or use of EVMs.
9. User assumes sole responsibility to determine whether EVMs may be subject to any applicable federal, state, or local laws and regulatory requirements (including but not limited to U.S. Food and Drug Administration regulations, if applicable) related to its handling and use of EVMs and, if applicable, compliance in all respects with such laws and regulations.
10. User has sole responsibility to ensure the safety of any activities to be conducted by it and its employees, affiliates, contractors or designees, with respect to handling and using EVMs. Further, user is responsible to ensure that any interfaces (electronic and/or mechanical) between EVMs and any human body are designed with suitable isolation and means to safely limit accessible leakage currents to minimize the risk of electrical shock hazard.
11. User shall employ reasonable safeguards to ensure that user's use of EVMs will not result in any property damage, injury or death, even if EVMs should fail to perform as described or expected.
12. User shall be solely responsible for proper disposal and recycling of EVMs consistent with all applicable federal, state, and local requirements.

Certain Instructions. User shall operate EVMs within TI's recommended specifications and environmental considerations per the user's guide, accompanying documentation, and any other applicable requirements. Exceeding the specified ratings (including but not limited to input and output voltage, current, power, and environmental ranges) for EVMs may cause property damage, personal injury or death. If there are questions concerning these ratings, user should contact a TI field representative prior to connecting interface electronics including input power and intended loads. Any loads applied outside of the specified output range may result in unintended and/or inaccurate operation and/or possible permanent damage to the EVM and/or interface electronics. Please consult the applicable EVM user's guide prior to connecting any load to the EVM output. If there is uncertainty as to the load specification, please contact a TI field representative. During normal operation, some circuit components may have case temperatures greater than 60°C as long as the input and output are maintained at a normal ambient operating temperature. These components include but are not limited to linear regulators, switching transistors, pass transistors, and current sense resistors which can be identified using EVMs' schematics located in the applicable EVM user's guide. When placing measurement probes near EVMs during normal operation, please be aware that EVMs may become very warm. As with all electronic evaluation tools, only qualified personnel knowledgeable in electronic measurement and diagnostics normally found in development environments should use EVMs.

Agreement to Defend, Indemnify and Hold Harmless. User agrees to defend, indemnify, and hold TI, its directors, officers, employees, agents, representatives, affiliates, licensors and their representatives harmless from and against any and all claims, damages, losses, expenses, costs and liabilities (collectively, "Claims") arising out of, or in connection with, any handling and/or use of EVMs. User's indemnity shall apply whether Claims arise under law of tort or contract or any other legal theory, and even if EVMs fail to perform as described or expected.

Safety-Critical or Life-Critical Applications. If user intends to use EVMs in evaluations of safety critical applications (such as life support), and a failure of a TI product considered for purchase by user for use in user's product would reasonably be expected to cause severe personal injury or death such as devices which are classified as FDA Class III or similar classification, then user must specifically notify TI of such intent and enter into a separate Assurance and Indemnity Agreement.

RADIO FREQUENCY REGULATORY COMPLIANCE INFORMATION FOR EVALUATION MODULES

Texas Instruments Incorporated (TI) evaluation boards, kits, and/or modules (EVMs) and/or accompanying hardware that is marketed, sold, or loaned to users may or may not be subject to radio frequency regulations in specific countries.

General Statement for EVMs Not Including a Radio

For EVMs not including a radio and not subject to the U.S. Federal Communications Commission (FCC) or Industry Canada (IC) regulations, TI intends EVMs to be used only for engineering development, demonstration, or evaluation purposes. EVMs are not finished products typically fit for general consumer use. EVMs may nonetheless generate, use, or radiate radio frequency energy, but have not been tested for compliance with the limits of computing devices pursuant to part 15 of FCC or the ICES-003 rules. Operation of such EVMs may cause interference with radio communications, in which case the user at his own expense will be required to take whatever measures may be required to correct this interference.

General Statement for EVMs including a radio

User Power/Frequency Use Obligations: For EVMs including a radio, the radio included in such EVMs is intended for development and/or professional use only in legally allocated frequency and power limits. Any use of radio frequencies and/or power availability in such EVMs and their development application(s) must comply with local laws governing radio spectrum allocation and power limits for such EVMs. It is the user's sole responsibility to only operate this radio in legally acceptable frequency space and within legally mandated power limitations. Any exceptions to this are strictly prohibited and unauthorized by TI unless user has obtained appropriate experimental and/or development licenses from local regulatory authorities, which is the sole responsibility of the user, including its acceptable authorization.

U.S. Federal Communications Commission Compliance

For EVMs Annotated as FCC – FEDERAL COMMUNICATIONS COMMISSION Part 15 Compliant

Caution

This device complies with part 15 of the FCC Rules. Operation is subject to the following two conditions: (1) This device may not cause harmful interference, and (2) this device must accept any interference received, including interference that may cause undesired operation. Changes or modifications could void the user's authority to operate the equipment.

FCC Interference Statement for Class A EVM devices

This equipment has been tested and found to comply with the limits for a Class A digital device, pursuant to part 15 of the FCC Rules. These limits are designed to provide reasonable protection against harmful interference when the equipment is operated in a commercial environment. This equipment generates, uses, and can radiate radio frequency energy and, if not installed and used in accordance with the instruction manual, may cause harmful interference to radio communications. Operation of this equipment in a residential area is likely to cause harmful interference in which case the user will be required to correct the interference at its own expense.

FCC Interference Statement for Class B EVM devices

This equipment has been tested and found to comply with the limits for a Class B digital device, pursuant to part 15 of the FCC Rules. These limits are designed to provide reasonable protection against harmful interference in a residential installation. This equipment generates, uses and can radiate radio frequency energy and, if not installed and used in accordance with the instructions, may cause harmful interference to radio communications. However, there is no guarantee that interference will not occur in a particular installation. If this equipment does cause harmful interference to radio or television reception, which can be determined by turning the equipment off and on, the user is encouraged to try to correct the interference by one or more of the following measures:

- Reorient or relocate the receiving antenna.
- Increase the separation between the equipment and receiver.
- Connect the equipment into an outlet on a circuit different from that to which the receiver is connected.
- Consult the dealer or an experienced radio/TV technician for help.

Industry Canada Compliance (English)

For EVMs Annotated as IC – INDUSTRY CANADA Compliant:

This Class A or B digital apparatus complies with Canadian ICES-003.

Changes or modifications not expressly approved by the party responsible for compliance could void the user's authority to operate the equipment.

Concerning EVMs Including Radio Transmitters

This device complies with Industry Canada licence-exempt RSS standard(s). Operation is subject to the following two conditions: (1) this device may not cause interference, and (2) this device must accept any interference, including interference that may cause undesired operation of the device.

Concerning EVMs Including Detachable Antennas

Under Industry Canada regulations, this radio transmitter may only operate using an antenna of a type and maximum (or lesser) gain approved for the transmitter by Industry Canada. To reduce potential radio interference to other users, the antenna type and its gain should be so chosen that the equivalent isotropically radiated power (e.i.r.p.) is not more than that necessary for successful communication.

This radio transmitter has been approved by Industry Canada to operate with the antenna types listed in the user guide with the maximum permissible gain and required antenna impedance for each antenna type indicated. Antenna types not included in this list, having a gain greater than the maximum gain indicated for that type, are strictly prohibited for use with this device.

Canada Industry Canada Compliance (French)

Cet appareil numérique de la classe A ou B est conforme à la norme NMB-003 du Canada

Les changements ou les modifications pas expressément approuvés par la partie responsable de la conformité ont pu vider l'autorité de l'utilisateur pour actionner l'équipement.

Concernant les EVMs avec appareils radio

Le présent appareil est conforme aux CNR d'Industrie Canada applicables aux appareils radio exempts de licence. L'exploitation est autorisée aux deux conditions suivantes : (1) l'appareil ne doit pas produire de brouillage, et (2) l'utilisateur de l'appareil doit accepter tout brouillage radioélectrique subi, même si le brouillage est susceptible d'en compromettre le fonctionnement.

Concernant les EVMs avec antennes détachables

Conformément à la réglementation d'Industrie Canada, le présent émetteur radio peut fonctionner avec une antenne d'un type et d'un gain maximal (ou inférieur) approuvé pour l'émetteur par Industrie Canada. Dans le but de réduire les risques de brouillage radioélectrique à l'intention des autres utilisateurs, il faut choisir le type d'antenne et son gain de sorte que la puissance isotrope rayonnée équivalente (p.i.r.e.) ne dépasse pas l'intensité nécessaire à l'établissement d'une communication satisfaisante.

Le présent émetteur radio a été approuvé par Industrie Canada pour fonctionner avec les types d'antenne énumérés dans le manuel d'usage et ayant un gain admissible maximal et l'impédance requise pour chaque type d'antenne. Les types d'antenne non inclus dans cette liste, ou dont le gain est supérieur au gain maximal indiqué, sont strictement interdits pour l'exploitation de l'émetteur.

Mailing Address: Texas Instruments, Post Office Box 655303, Dallas, Texas 75265
Copyright © 2014, Texas Instruments Incorporated

Important Notice for Users of EVMs Considered “Radio Frequency Products” in Japan

EVMs entering Japan are NOT certified by TI as conforming to Technical Regulations of Radio Law of Japan.

If user uses EVMs in Japan, user is required by Radio Law of Japan to follow the instructions below with respect to EVMs:

1. Use EVMs in a shielded room or any other test facility as defined in the notification #173 issued by Ministry of Internal Affairs and Communications on March 28, 2006, based on Sub-section 1.1 of Article 6 of the Ministry's Rule for Enforcement of Radio Law of Japan,
2. Use EVMs only after user obtains the license of Test Radio Station as provided in Radio Law of Japan with respect to EVMs, or
3. Use of EVMs only after user obtains the Technical Regulations Conformity Certification as provided in Radio Law of Japan with respect to EVMs. Also, do not transfer EVMs, unless user gives the same notice above to the transferee. Please note that if user does not follow the instructions above, user will be subject to penalties of Radio Law of Japan.

<http://www.tij.co.jp>

【無線電波を送信する製品の開発キットをお使いになる際の注意事項】本開発キットは技術基準適合証明を受けておりません。本製品のご使用に際しては、電波法遵守のため、以下のいずれかの措置を取っていただく必要がありますのでご注意ください。

1. 電波法施行規則第6条第1項第1号に基づく平成18年3月28日総務省告示第173号で定められた電波暗室等の試験設備でご使用いただく。
2. 実験局の免許を取得後ご使用いただく。
3. 技術基準適合証明を取得後ご使用いただく。。

なお、本製品は、上記の「ご使用にあたっての注意」を譲渡先、移転先に通知しない限り、譲渡、移転できないものとします

上記を遵守頂けない場合は、電波法の罰則が適用される可能性があることをご留意ください。

日本テキサス・インスツルメンツ株式会社

東京都新宿区西新宿6丁目24番1号

西新宿三井ビル

<http://www.tij.co.jp>

Texas Instruments Japan Limited

(address) 24-1, Nishi-Shinjuku 6 chome, Shinjuku-ku, Tokyo, Japan

IMPORTANT NOTICE

Texas Instruments Incorporated and its subsidiaries (TI) reserve the right to make corrections, enhancements, improvements and other changes to its semiconductor products and services per JESD46, latest issue, and to discontinue any product or service per JESD48, latest issue. Buyers should obtain the latest relevant information before placing orders and should verify that such information is current and complete. All semiconductor products (also referred to herein as "components") are sold subject to TI's terms and conditions of sale supplied at the time of order acknowledgment.

TI warrants performance of its components to the specifications applicable at the time of sale, in accordance with the warranty in TI's terms and conditions of sale of semiconductor products. Testing and other quality control techniques are used to the extent TI deems necessary to support this warranty. Except where mandated by applicable law, testing of all parameters of each component is not necessarily performed.

TI assumes no liability for applications assistance or the design of Buyers' products. Buyers are responsible for their products and applications using TI components. To minimize the risks associated with Buyers' products and applications, Buyers should provide adequate design and operating safeguards.

TI does not warrant or represent that any license, either express or implied, is granted under any patent right, copyright, mask work right, or other intellectual property right relating to any combination, machine, or process in which TI components or services are used. Information published by TI regarding third-party products or services does not constitute a license to use such products or services or a warranty or endorsement thereof. Use of such information may require a license from a third party under the patents or other intellectual property of the third party, or a license from TI under the patents or other intellectual property of TI.

Reproduction of significant portions of TI information in TI data books or data sheets is permissible only if reproduction is without alteration and is accompanied by all associated warranties, conditions, limitations, and notices. TI is not responsible or liable for such altered documentation. Information of third parties may be subject to additional restrictions.

Resale of TI components or services with statements different from or beyond the parameters stated by TI for that component or service voids all express and any implied warranties for the associated TI component or service and is an unfair and deceptive business practice. TI is not responsible or liable for any such statements.

Buyer acknowledges and agrees that it is solely responsible for compliance with all legal, regulatory and safety-related requirements concerning its products, and any use of TI components in its applications, notwithstanding any applications-related information or support that may be provided by TI. Buyer represents and agrees that it has all the necessary expertise to create and implement safeguards which anticipate dangerous consequences of failures, monitor failures and their consequences, lessen the likelihood of failures that might cause harm and take appropriate remedial actions. Buyer will fully indemnify TI and its representatives against any damages arising out of the use of any TI components in safety-critical applications.

In some cases, TI components may be promoted specifically to facilitate safety-related applications. With such components, TI's goal is to help enable customers to design and create their own end-product solutions that meet applicable functional safety standards and requirements. Nonetheless, such components are subject to these terms.

No TI components are authorized for use in FDA Class III (or similar life-critical medical equipment) unless authorized officers of the parties have executed a special agreement specifically governing such use.

Only those TI components which TI has specifically designated as military grade or "enhanced plastic" are designed and intended for use in military/aerospace applications or environments. Buyer acknowledges and agrees that any military or aerospace use of TI components which have **not** been so designated is solely at the Buyer's risk, and that Buyer is solely responsible for compliance with all legal and regulatory requirements in connection with such use.

TI has specifically designated certain components as meeting ISO/TS16949 requirements, mainly for automotive use. In any case of use of non-designated products, TI will not be responsible for any failure to meet ISO/TS16949.

Products

Audio	www.ti.com/audio
Amplifiers	amplifier.ti.com
Data Converters	dataconverter.ti.com
DLP® Products	www.dlp.com
DSP	dsp.ti.com
Clocks and Timers	www.ti.com/clocks
Interface	interface.ti.com
Logic	logic.ti.com
Power Mgmt	power.ti.com
Microcontrollers	microcontroller.ti.com
RFID	www.ti-rfid.com
OMAP Applications Processors	www.ti.com/omap
Wireless Connectivity	www.ti.com/wirelessconnectivity

Applications

Automotive and Transportation	www.ti.com/automotive
Communications and Telecom	www.ti.com/communications
Computers and Peripherals	www.ti.com/computers
Consumer Electronics	www.ti.com/consumer-apps
Energy and Lighting	www.ti.com/energy
Industrial	www.ti.com/industrial
Medical	www.ti.com/medical
Security	www.ti.com/security
Space, Avionics and Defense	www.ti.com/space-avionics-defense
Video and Imaging	www.ti.com/video

TI E2E Community

e2e.ti.com