

MGC3130 Single Zone Evaluation Kit (Sabrewing)

Part Number. DM160217

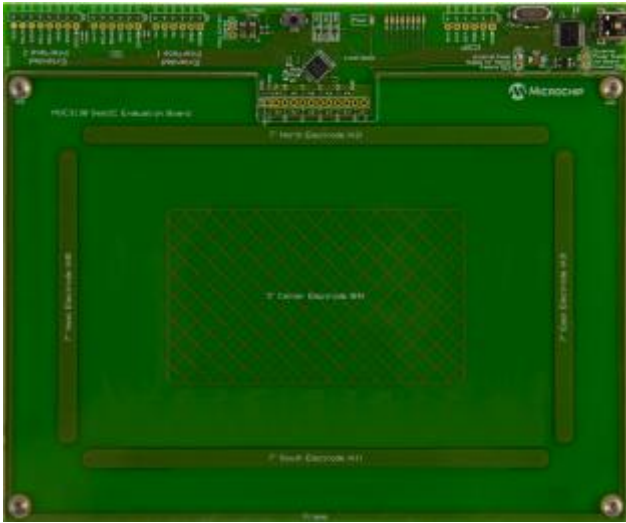

The single zone evaluation kit “Sabrewing” is a complete solution for exploring the low-cost, high-performance MGC3130 3D Tracking and Gesture Controller based on Microchip’s GestIC® technology.

Microchip’s feature-rich Aurea Graphical User Interface (GUI) running on the Windows 7 Operating System, provides control of the MGC3130’s settings, making it easy to update and save parameters.

- 7” sensing electrode
- Powered by USB
- GestIC technology Colibri Gesture Suite

Package contents: MGC3130 – Single-Zone Evaluation Kit “Sabrewing” and USB cable



MICROCHIP

**MGC3130 – Sabrewing
Single-Zone Evaluation Kit
User's Guide**

Note the following details of the code protection feature on Microchip devices:

- Microchip products meet the specification contained in their particular Microchip Data Sheet.
- Microchip believes that its family of products is one of the most secure families of its kind on the market today, when used in the intended manner and under normal conditions.
- There are dishonest and possibly illegal methods used to breach the code protection feature. All of these methods, to our knowledge, require using the Microchip products in a manner outside the operating specifications contained in Microchip's Data Sheets. Most likely, the person doing so is engaged in theft of intellectual property.
- Microchip is willing to work with the customer who is concerned about the integrity of their code.
- Neither Microchip nor any other semiconductor manufacturer can guarantee the security of their code. Code protection does not mean that we are guaranteeing the product as "unbreakable."

Code protection is constantly evolving. We at Microchip are committed to continuously improving the code protection features of our products. Attempts to break Microchip's code protection feature may be a violation of the Digital Millennium Copyright Act. If such acts allow unauthorized access to your software or other copyrighted work, you may have a right to sue for relief under that Act.

Information contained in this publication regarding device applications and the like is provided only for your convenience and may be superseded by updates. It is your responsibility to ensure that your application meets with your specifications. MICROCHIP MAKES NO REPRESENTATIONS OR WARRANTIES OF ANY KIND WHETHER EXPRESS OR IMPLIED, WRITTEN OR ORAL, STATUTORY OR OTHERWISE, RELATED TO THE INFORMATION, INCLUDING BUT NOT LIMITED TO ITS CONDITION, QUALITY, PERFORMANCE, MERCHANTABILITY OR FITNESS FOR PURPOSE. Microchip disclaims all liability arising from this information and its use. Use of Microchip devices in life support and/or safety applications is entirely at the buyer's risk, and the buyer agrees to defend, indemnify and hold harmless Microchip from any and all damages, claims, suits, or expenses resulting from such use. No licenses are conveyed, implicitly or otherwise, under any Microchip intellectual property rights.

Trademarks

The Microchip name and logo, the Microchip logo, dsPIC, FlashFlex, KEELOQ, KEELOQ logo, MPLAB, PIC, PICmicro, PICSTART, PIC³² logo, rPIC, SST, SST Logo, SuperFlash and UNI/O are registered trademarks of Microchip Technology Incorporated in the U.S.A. and other countries.

FilterLab, Hampshire, HI-TECH C, Linear Active Thermistor, MTP, SEEVAL and The Embedded Control Solutions Company are registered trademarks of Microchip Technology Incorporated in the U.S.A.

Silicon Storage Technology is a registered trademark of Microchip Technology Inc. in other countries.

Analog-for-the-Digital Age, Application Maestro, BodyCom, chipKIT, chipKIT logo, CodeGuard, dsPICDEM, dsPICDEM.net, dsPICworks, dsSPEAK, ECAN, ECONOMONITOR, FanSense, HI-TIDE, In-Circuit Serial Programming, ICSP, Mindi, MiWi, MPASM, MPF, MPLAB Certified logo, MPLIB, MPLINK, mTouch, Omniscent Code Generation, PICC, PICC-18, PICDEM, PICDEM.net, PICkit, PICtail, REAL ICE, rLAB, Select Mode, SQI, Serial Quad I/O, Total Endurance, TSHARC, UniWinDriver, WiperLock, ZENA and Z-Scale are trademarks of Microchip Technology Incorporated in the U.S.A. and other countries.

SQTP is a service mark of Microchip Technology Incorporated in the U.S.A.

GestIC and ULPP are registered trademarks of Microchip Technology Germany II GmbH & Co. KG, a subsidiary of Microchip Technology Inc., in other countries.

All other trademarks mentioned herein are property of their respective companies.

© 2013, Microchip Technology Incorporated, Printed in the U.S.A., All Rights Reserved.

 Printed on recycled paper.

ISBN: 9781620770481

**QUALITY MANAGEMENT SYSTEM
CERTIFIED BY DNV
= ISO/TS 16949 =**

Microchip received ISO/TS-16949:2009 certification for its worldwide headquarters, design and wafer fabrication facilities in Chandler and Tempe, Arizona; Gresham, Oregon and design centers in California and India. The Company's quality system processes and procedures are for its PIC[®] MCUs and dsPIC[®] DSCs, KEELOQ[®] code hopping devices, Serial EEPROMs, microperipherals, nonvolatile memory and analog products. In addition, Microchip's quality system for the design and manufacture of development systems is ISO 9001:2000 certified.



MGC3130 – SABREWING SINGLE-ZONE EVALUATION KIT USER'S GUIDE

Table of Contents

Chapter 1. Overview

1.1 Introduction	11
1.1.1 MGC3130 System Overview	11
1.1.2 MGC3130 Controller	11
1.1.3 GestIC® Library	12
1.1.4 External Electrodes	12
1.2 Sabrewing Evaluation Kit	12
1.2.1 Sabrewing Single-Zone Evaluation Board	12
1.2.2 MGC3130 Software Release Package	13

Chapter 2. Getting Started

2.1 Prerequisites	15
2.2 Step 1: Connecting Sabrewing with your PC	15
2.3 Step 2: Install Windows CDC Driver	15
2.4 Step 3: Start Aurea	15

Chapter 3. MGC3130 – Sabrewing Evaluation Board

3.1 Board Construction and Layout	17
3.2 MGC3130 Reference Circuitry	18
3.3 Electrodes	18
3.4 I ² C™ to USB Bridge	21

Chapter 4. Troubleshooting

Appendix A. Schematics

A.1 Introduction	25
A.2 Bill of Material	25
A.3 Board Schematic and Layout	26

Appendix B. Sensitivity Profile and Capacities

B.1 Introduction	29
B.2 Sensitivity Profiles	29
B.3 Electrode Capacities	30

Appendix C. Driver Installation Manual

Appendix D. Glossary

NOTES:



MGC3130 – SABREWING SINGLE-ZONE EVALUATION KIT USER'S GUIDE

Preface

NOTICE TO CUSTOMERS

All documentation becomes dated, and this manual is no exception. Microchip tools and documentation are constantly evolving to meet customer needs, so some actual dialogs and/or tool descriptions may differ from those in this document. Please refer to our web site (www.microchip.com) to obtain the latest documentation available.

Documents are identified with a “DS” number. This number is located on the bottom of each page, in front of the page number. The numbering convention for the DS number is “DSXXXXA”, where “XXXX” is the document number and “A” is the revision level of the document.

For the most up-to-date information on development tools, see the MPLAB IDE online help. Select the Help menu, and then Topics to open a list of available online help files.

INTRODUCTION

This chapter contains general information that will be useful to know before using the Sabrewing Single-Zone Evaluation Kit. Items discussed in this chapter include:

- Document Layout
- Conventions Used in this Guide
- Warranty Registration
- Recommended Reading
- The Microchip Web Site
- Development Systems Customer Change Notification Service
- Customer Support
- Software License Information
- Document Revision History

DOCUMENT LAYOUT

This document describes the installation and use of the Sabrewing Single-Zone Evaluation Kit. The document is organized as follows:

- **Chapter 1. “Overview”**
- **Chapter 2. “Getting Started”**
- **Chapter 3. “MGC3130 – Sabrewing Evaluation Board”**
- **Chapter 4. “Troubleshooting”**
- **Appendix A. “Schematics”**
- **Appendix B. “Sensitivity Profile and Capacities”**
- **Appendix C. “Driver Installation Manual”**
- **Appendix D. “Glossary”**

CONVENTIONS USED IN THIS GUIDE

This manual uses the following documentation conventions:

DOCUMENTATION CONVENTIONS

Description	Represents	Examples
Arial font:		
Italic characters	Referenced books	<i>MPLAB IDE User’s Guide</i>
	Emphasized text	...is the <i>only</i> compiler...
Initial caps	A window	the Output window
	A dialog	the Settings dialog
	A menu selection	select Enable Programmer
Quotes	A field name in a window or dialog	“Save project before build”
Underlined, italic text with right angle bracket	A menu path	<u>File>Save</u>
Bold characters	A dialog button	Click OK
	A tab	Click the Power tab
N'Rnnnn	A number in verilog format, where N is the total number of digits, R is the radix and n is a digit.	4'b0010, 2'hF1
Text in angle brackets < >	A key on the keyboard	Press <Enter>, <F1>
Courier New font:		
Plain Courier New	Sample source code	#define START
	Filenames	autoexec.bat
	File paths	c:\mcc18\h
	Keywords	_asm, _endasm, static
	Command-line options	-Opa+, -Opa-
	Bit values	0, 1
	Constants	0xFF, 'A'
Italic Courier New	A variable argument	<i>file.o</i> , where <i>file</i> can be any valid filename
Square brackets []	Optional arguments	mcc18 [options] <i>file</i> [options]
Curly brackets and pipe character: { }	Choice of mutually exclusive arguments; an OR selection	errorlevel {0 1}
Ellipses...	Replaces repeated text	var_name [, var_name...]
	Represents code supplied by user	void main (void) { ... }

WARRANTY REGISTRATION

Please complete the enclosed Warranty Registration Card and mail it promptly. Sending in the Warranty Registration Card entitles users to receive new product updates. Interim software releases are available at the Microchip web site.

RECOMMENDED READING

This user's guide describes how to use the Sabrewing Single-Zone Evaluation Kit. Other useful documents are listed below. The following Microchip documents are available and recommended as supplemental reference resources.

MGC3130 – Single-Zone 3D Gesture Controller Data Sheet (DS41667)

Consult this document for information regarding the MGC3130 3D Tracking and Gesture Controller.

MGC3130 – Aurea Graphical User Interface User's Guide (DS41681)

This document describes the installation and use of Aurea. Microchip's Aurea is a Windows-based graphical user interface that can be used to demonstrate, evaluate and configure Microchip's MGC3130 3D tracking and Gesture Controller.

THE MICROCHIP WEB SITE

Microchip provides online support via our web site at www.microchip.com. This web site is used as a means to make files and information easily available to customers.

Information about GestIC® technology and MGC3130 can be directly accessed via www.microchip.com/gestic.

Documentation and software releases of the Sabrewing Evaluation Board can be found at www.microchip.com/GestICGettingStarted.

DEVELOPMENT SYSTEMS CUSTOMER CHANGE NOTIFICATION SERVICE

Microchip’s customer notification service helps keep customers current on Microchip products. Subscribers will receive e-mail notification whenever there are changes, updates, revisions or errata related to a specified product family or development tool of interest.

To register, access the Microchip web site at www.microchip.com, click on Customer Change Notification and follow the registration instructions.

The Development Systems product group categories are:

- **Compilers** – The latest information on Microchip C compilers, assemblers, linkers and other language tools. These include all MPLAB® C compilers; all MPLAB assemblers (including MPASM™ assembler); all MPLAB linkers (including MPLINK™ object linker); and all MPLAB librarians (including MPLIB™ object librarian).
- **Emulators** – The latest information on Microchip in-circuit emulators. This includes the MPLAB® REAL ICE™ and MPLAB ICE 2000 in-circuit emulators.
- **In-Circuit Debuggers** – The latest information on the Microchip in-circuit debuggers. This includes MPLAB ICD 3 in-circuit debuggers and PICKit™ 3 debug express.
- **MPLAB IDE** – The latest information on Microchip MPLAB IDE, the Windows Integrated Development Environment for development systems tools. This list is focused on the MPLAB IDE, MPLAB IDE Project Manager, MPLAB Editor and MPLAB SIM simulator, as well as general editing and debugging features.
- **Programmers** – The latest information on Microchip programmers. These include production programmers such as MPLAB REAL ICE in-circuit emulator, MPLAB ICD 3 in-circuit debugger and MPLAB PM3 device programmers. Also included are nonproduction development programmers such as PICSTART® Plus and PICKit 2 and 3.

CUSTOMER SUPPORT

Users of Microchip products can receive assistance through several channels:

- Distributor or Representative
- Local Sales Office
- Field Application Engineer (FAE)
- Technical Support

Customers should contact their distributor, representative or field application engineer (FAE) for support. Local sales offices are also available to help customers.

Technical support is available through the web site at:

<http://www.microchip.com/support>.

SOFTWARE LICENSE INFORMATION

Copyright (C) 2012 Microchip Technology Inc. and its subsidiaries ("Microchip"). All rights reserved.

You are permitted to use the Aurea software, GestIC API, and other accompanying software with Microchip products. Refer to the license agreement accompanying this software, if any, for additional info regarding your rights and obligations.

SOFTWARE AND DOCUMENTATION ARE PROVIDED "AS IS" WITHOUT WARRANTY OF ANY KIND, EITHER EXPRESS OR IMPLIED, INCLUDING WITHOUT LIMITATION, ANY WARRANTY OF MERCHANTABILITY, TITLE, NON-INFRINGEMENT AND FITNESS FOR A PARTICULAR PURPOSE. IN NO EVENT SHALL MICROCHIP, SMSC, OR ITS LICENSORS BE LIABLE OR OBLIGATED UNDER CONTRACT, NEGLIGENCE, STRICT LIABILITY, CONTRIBUTION, BREACH OF WARRANTY, OR OTHER LEGAL EQUITABLE THEORY FOR ANY DIRECT OR INDIRECT DAMAGES OR EXPENSES INCLUDING BUT NOT LIMITED TO ANY INCIDENTAL, SPECIAL, INDIRECT OR CONSEQUENTIAL DAMAGES, OR OTHER SIMILAR COSTS.

DOCUMENT REVISION HISTORY

Revision A (March 2013)

- Initial release of the document.

NOTES:

Chapter 1. Overview

1.1 INTRODUCTION

1.1.1 MGC3130 System Overview

The MGC3130 is the first product based on Microchip’s GestIC® technology. It is developed as a mixed signal controller. The MGC3130 has one transmit and five very sensitive receive channels that are capable to detect distortions of a transmitted electrical field (E-field) corresponding to capacitive changes in the femtofarad ($1\text{fF} = 10^{-15}\text{F}$) range. In order to transmit and receive an electrical field, electrodes have to be connected to the transmitting and receiving channels of the MGC3130 controller. The spatial arrangement of the electrodes allow the chip to determine the center of gravity of the electric field distortion, and thus position tracking of a user’s hand in the detection space.

The entire system solution is composed by three main building blocks (see Figure 1-1):

- MGC3130 Controller Chip
- Embedded GestIC Library
- External Electrodes

FIGURE 1-1: MGC3130 CONTROLLER SYSTEM

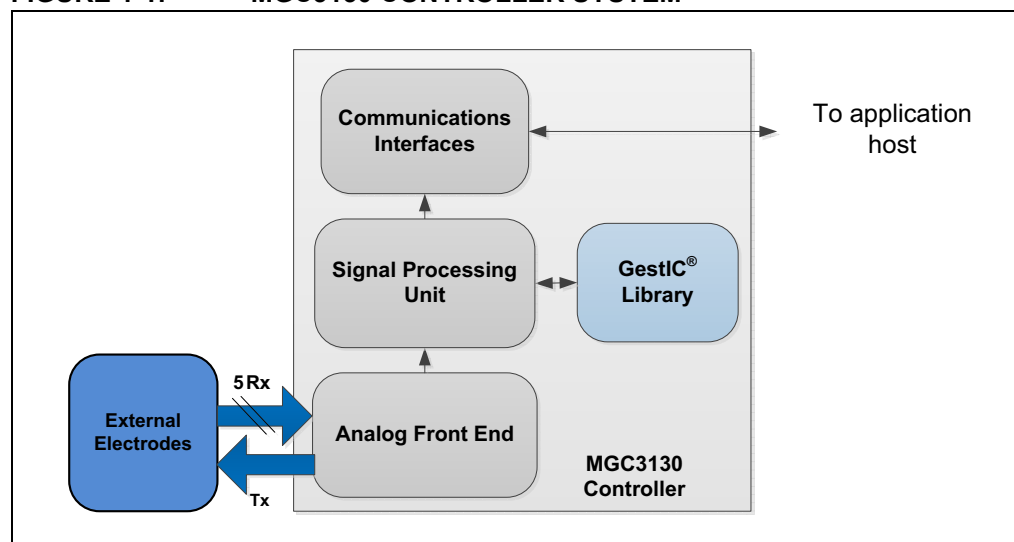

1.1.2 MGC3130 Controller

The MGC3130 features the following main building blocks:

- Low-noise Analog Front End (AFE)
- Digital Signal Processing Unit (SPU)
- Flexible Communication Interfaces

The MGC3130 controller provides a transmit signal to generate the E-field, conditions the analog signals from the receiving electrodes and processes this data digitally on the SPU. Data exchange between the MGC3130 and the host is conducted via the communication interfaces.

Please refer to the “*MGC3130 Single-Zone 3D Gesture Controller Data Sheet*” (DS41667) for more details.

1.1.3 GestIC® Library

The embedded GestIC library is optimized to ensure continuous and real-time free-space Position Tracking and Gesture Recognition, concurrently. It is fully configurable and allows required parameterization for individual application and electrode layouts.

1.1.4 External Electrodes

Five Rx electrodes and one Tx electrode are connected to MGC3130. An electrode needs to be individually designed for optimal E-field distribution and detection of E-field variations inflicted by a user.

1.2 SABREWING EVALUATION KIT

The MGC3130 Single-Zone Evaluation Kit “Sabrewing” is designed for evaluation of Microchip’s MGC3130 3D Tracking and Gesture Controller core features which contains:

- Hand Position Tracking in three dimensions (x, y, z)
- Hand Gesture Recognition based on a stochastic Hidden Markov Model (HMM)
- Approach detection for power saving

1.2.1 Sabrewing Single-Zone Evaluation Board

The Sabrewing Evaluation Board features the MGC3130 reference circuit, an I²C™ to USB Bridge and built-in 7" single-zone frame electrodes.

The package contains:

- Sabrewing Evaluation Board
- USB Cable

FIGURE 1-2: SABREWING EVALUATION BOARD PACKAGE

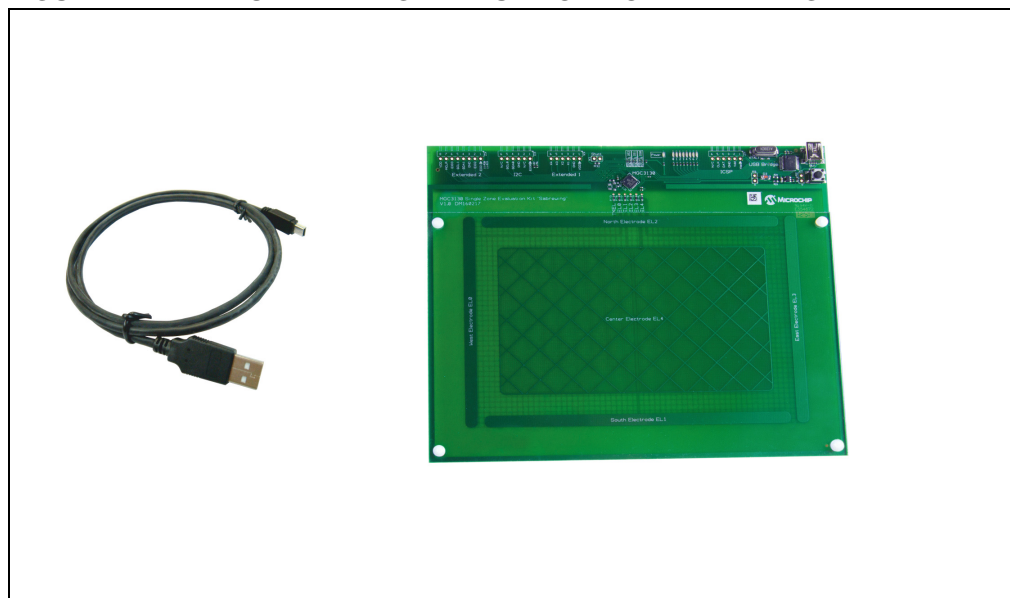

1.2.2 MGC3130 Software Release Package

The MGC3130 software release package contains all relevant system software and can be downloaded from Microchip's web site www.microchip.com/GestICGettingStarted.

The package contains:

- Aurea PC software
- GestIC Library binary file
- Windows CDC driver

NOTES:

Chapter 2. Getting Started

2.1 PREREQUISITES

The following prerequisites have to be fulfilled to run the Sabrewing system:

- PC with Windows® XP, Windows 7 or Windows 8 operating system and USB 2.0 port
- Sabrewing Evaluation Board
- Latest MGC3130 software release package

The MGC3130 software release package is available as a .zip file

(www.microchip.com/GestICGettingStarted). Unzip the file, run `setup.exe` and install the release package to your PC. The folder structure is as shown in Figure 2-1.

FIGURE 2-1: FOLDER STRUCTURE

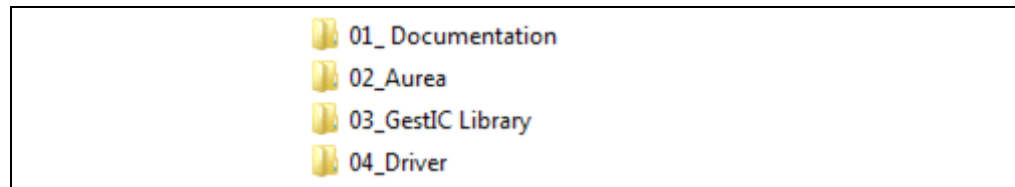

2.2 STEP 1: CONNECTING SABREWING WITH YOUR PC

Use the supplied USB cable to connect the Sabrewing Evaluation Board to your PC. The Power LED on the Sabrewing Board should illuminate. Furthermore, LED 1 and LED 2 should blink simultaneously.

In case LED 1 and LED 2 blink alternately, the Windows CDC driver is already installed on your PC. Please skip the next step and go to **Section 2.4 “Step 3: Start Aurea”**.

2.3 STEP 2: INSTALL WINDOWS CDC DRIVER

The Windows CDC driver can be found in the MGC3130 software release package folder `04_Driver`.

When the Sabrewing Evaluation Board is connected to your PC for the first time, Windows requests the appropriate device driver and guides you through the installation process.

Alternatively, you can install the driver manually, e.g. using the device manager. An example for Windows 7 is given in **Appendix C. “Driver Installation Manual”**.

2.4 STEP 3: START AUREA

Aurea Graphical User Interface, shown in Figure 2-2, is included in the MGC3130 software release package in the folder `02_Aurea`.

Open `Aurea.exe`. Aurea detects the connected device automatically and is ready for use. For more information on Aurea, refer to the “MGC3130 – Aurea Graphical User Interface User’s Guide” (DS41681).

FIGURE 2-2: AUREA GRAPHICAL USER INTERFACE

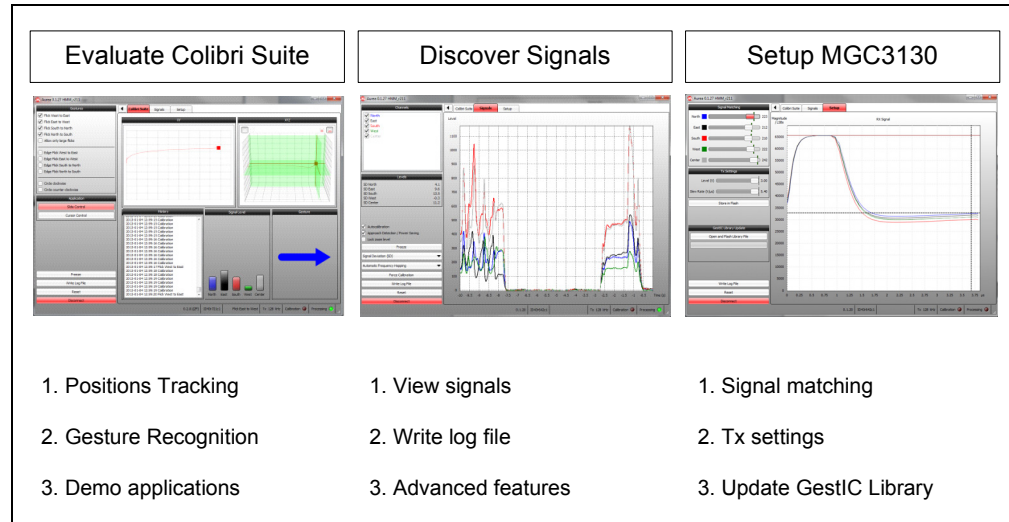

Chapter 3. MGC3130 – Sabrewing Evaluation Board

3.1 BOARD CONSTRUCTION AND LAYOUT

The Sabrewing Evaluation Board, shown as a block diagram in Figure 3-1, is organized in three sections:

- MGC3130 Reference Circuitry
- Built-in 7" frame sensing electrodes
- I²C to USB Bridge

In the following chapters, they are explained in detail.

FIGURE 3-1: SABREWING EVALUATION BOARD BLOCK DIAGRAM

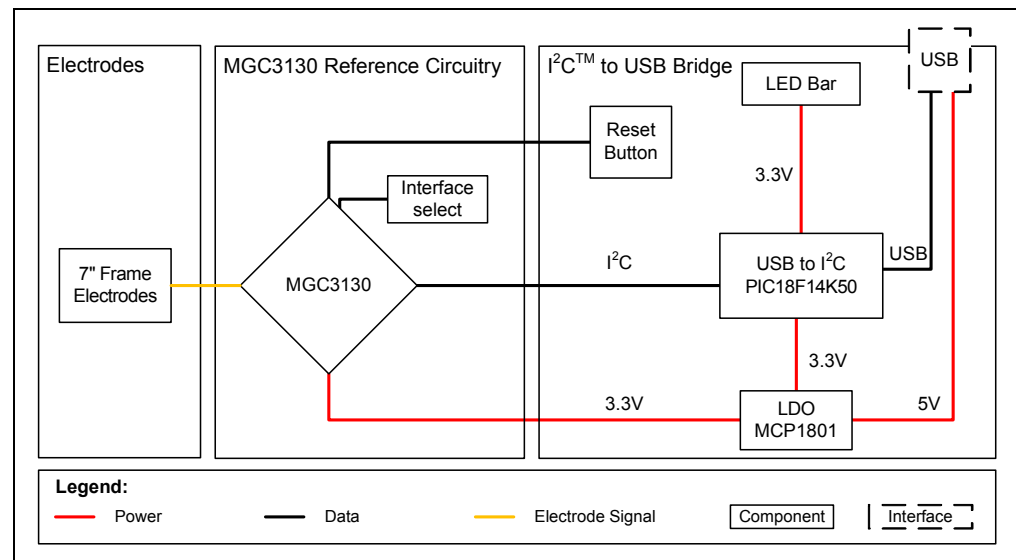

The key components of the Sabrewing Evaluation Board are listed below and highlighted in Figure 3-2:

1. MGC3130 3D Tracking and Gesture Controller
2. Built-in 7" frame electrodes
3. Interface select
4. LED bar signalling when board is powered and indicating the communication status
5. Microchip's PIC18F14K50 USB microcontroller passing messages between MGC3130 and the PC
6. USB mini-B connector to connect the board to a PC
7. Reset button resetting the MGC3130
8. Microchip's MCP1801 LDO voltage regulator converting 5V USB power to 3.3V board supply
9. Acrylic glass (180 x 116.5 x 2 mm) simulating the housing of a target device
10. Plastic rivets mounting the acrylic glass to the PCB

FIGURE 3-2: SABREWING EVALUATION BOARD KEY ELEMENTS

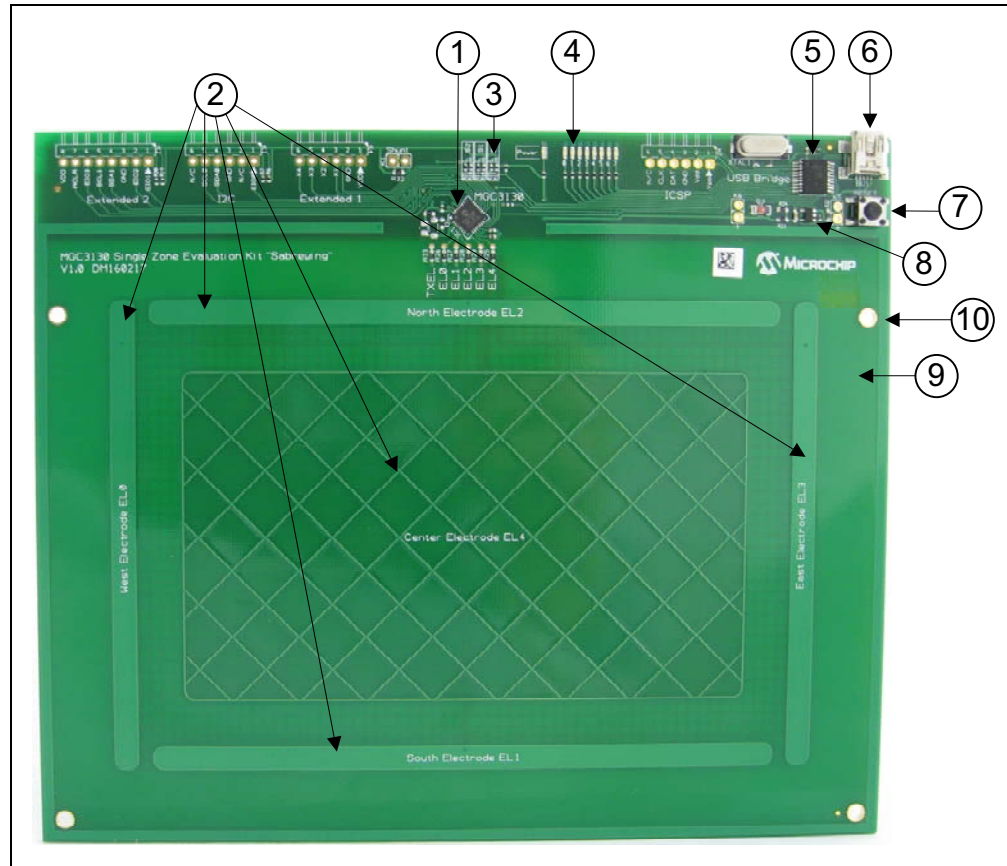

3.2 MGC3130 REFERENCE CIRCUITRY

The key element of the MGC3130 Reference Circuitry is Microchip’s MGC3130 3D Tracking and Gesture Controller. It is powered by a single 3.3V power supply. The MGC3130 Reset is controlled by the Reset button on the board or via the PIC18F14K50. The communication to the USB bridge is realized through I²C0.

The five Rx channels of the chip are connected to the electrodes via 1 kOhm resistors in order to suppress irradiated high-frequency signals.

Please refer to the “*MGC3130 Single-Zone 3D Gesture Controller Data Sheet*” (DS41667).

3.3 ELECTRODES

The Sabrewing Evaluation Board uses a Double Layer Electrode Design with the electrodes built right into the PCB. They consist of one Tx and five Rx electrodes (north, east, south, west, center), which are placed in different layers (Figure 3-3).

The dimensions on the electrode’s outer edges are 148 mm x 98.7 mm. The aspect ratio of the sensing area is 3:2.

MGC3130 – Sabrewing Evaluation Board

FIGURE 3-3: ELECTRODE LAYOUT

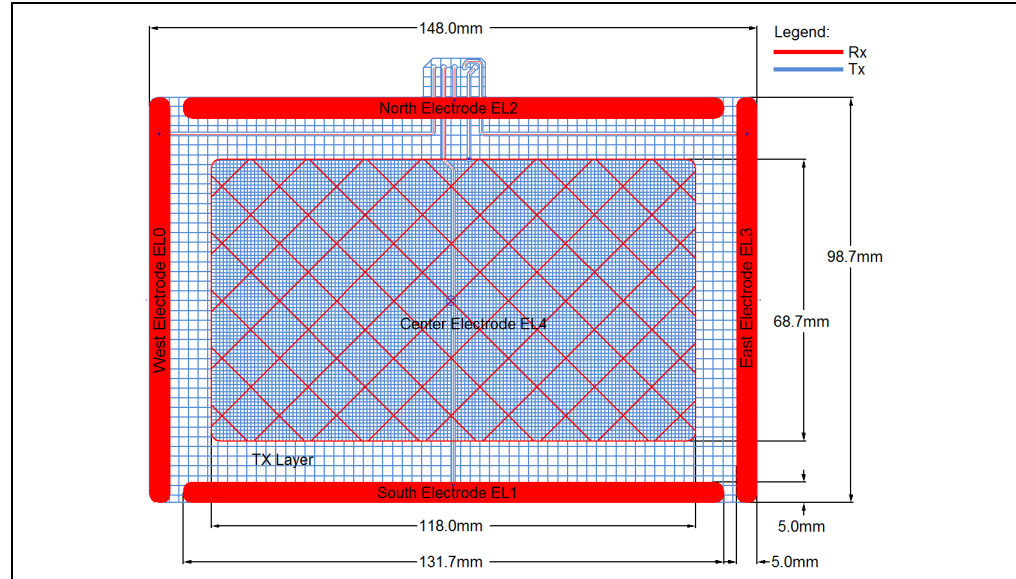

The electrode layout is based on a four-layer PCB design using FR4 material.

Three functional layers are used:

- Layer 1 (Top): Rx electrodes
- Layer 3: Tx electrode and Rx feeding lines
- Layer 4 (Bottom): Ground

Layer 2 is not used.

FIGURE 3-4: PCB LAYER STACK

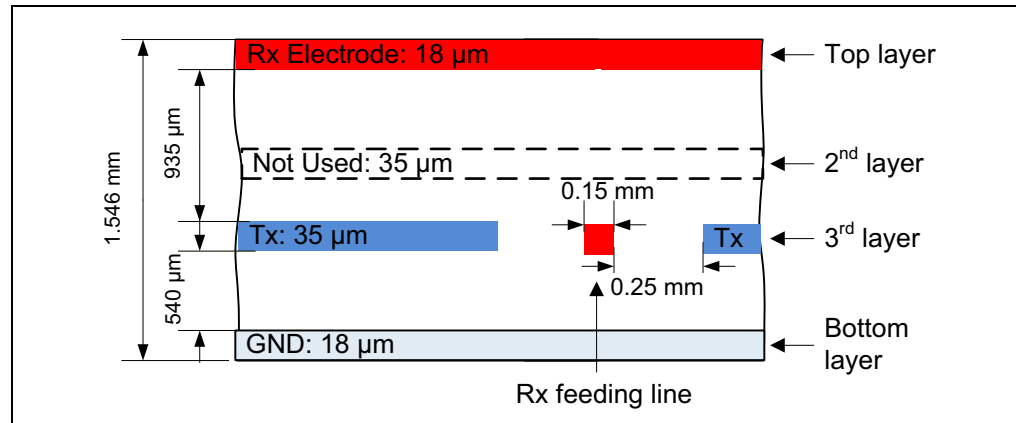

The design of Rx electrodes includes four frame electrodes and one center electrode, as shown in Figure 3-3. The frame electrodes are named according to their cardinal directions - north, east, south and west. The dimensions of the four Rx frame electrodes define the maximum sensing area. The center electrode is structured (hatched) to get a similar input signal level as the four frame electrodes.

The Tx electrode spans over the complete area underneath the Rx electrodes. It is structured to reduce the capacitances between Rx and Tx (C_{RXTX}). The area below the center electrode covers 50% of the copper plane, the area around only 20%.

The Rx feeding lines are also routed in the third layer. They are embedded into the Tx electrode (refer to Figure 3-3 and Figure 3-4). This supports shielding of the feeding lines.

Dimensions are given in Table 3-1.

MGC3130 – Sabrewing Single-Zone Evaluation Kit User’s Guide

In a target system design the GND layer is not required. It is added for the Sabrewing Board as a shielding layer and shall simulate the presence of static components which are placed in the target device underneath the sensing electrodes. In order to keep ground capacitances (C_{TxGND} , C_{RxGND}) below 1nF, the GND layer is structured in a way that 40% of the area is covered with copper.

- Note 1:** Please refer to the “*MGC3130 Single-Zone 3D Gesture Controller Data Sheet*” (DS41667) for the electrodes equivalent circuitry, capacitances (C_{RxTx} , C_{RxGND} , C_{TxGND}) and their typical values.
- 2:** The integration of GestIC® technology into a target device does not require the GND layer. If no shielding is needed, or if the device already contains grounded planes, a two layer design is preferable.

TABLE 3-1: ELECTRODE DESIGN

	Length	Width	Coverage
Horizontal Electrodes (Rx)	131.7 mm	5 mm	solid
Vertical Electrodes (Rx)	98.7 mm	5 mm	solid
Center Electrode (Rx)	118 mm	68.7 mm	5% structured
Tx Electrode (refer to Figure 3-3)	148 mm	98.7 mm	
Part I (under center Electrode)	118 mm	68.7 mm	50% structured
Part II (outside Part I)	148 mm	98.7 mm	20% structured
Ground Area	180 mm	126.6 mm	40% structured

The sensing area of the Sabrewing board, depicted in Figure 3-5, is defined as the area enclosed by the four frame electrodes. Depending on the parameterization, it can differ from the physical dimensions of the electrodes.

FIGURE 3-5: SENSING AREA

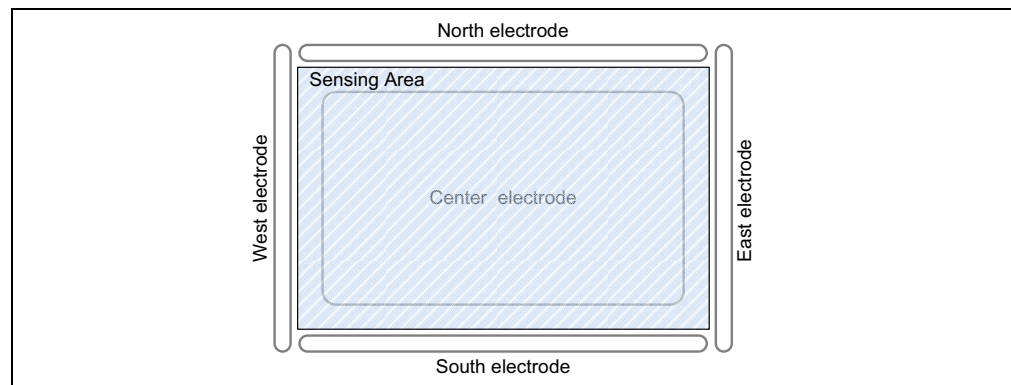

3.4 I²C™ TO USB BRIDGE

The communication between the MGC3130 and the host PC is controlled by the I²C to USB Bridge section. The message exchange is handled by Microchip's PIC18F14K50 USB microcontroller. The PIC18F14K50 is also used to indicate the communication status on a LED bar and to control MGC3130 hardware Reset.

The board is powered via the USB port. Microchip's Low Dropout (LDO) Voltage Regulator MCP1801 is used to transform the 5V USB power to 3.3V required for the MGC3130 and the PIC18F14K50.

The LEDs indicate the following:

- POWER – signals that the Sabrewing board is powered (3.3V)
- LED1/2 – blink simultaneously to indicate that there is no data transfer on the USB port
- LED1/2 – blink alternating to indicate that there is data transfer on the USB port
- LED 5 – is on when there is data on the I²C bus
- LEDs 0, 3, 4, 6 and 7 are not used

NOTES:

Chapter 4. Troubleshooting

POWER LED DOES NOT ILLUMINATE

In case the power LED does not illuminate, it is likely the board is not powered.

Possible Solutions:

1. Check the board is connected to your PC's USB port.
2. Change the USB cable or use a different USB port on your PC.
3. Check if the PC is switched on.

LED 1 AND LED 2 BLINK SIMULTANEOUSLY

When LED 1 and LED 2 blink simultaneously, there is no data transfer on the USB port.

Possible Solutions:

1. Make sure the Windows CDC driver is installed (refer to **Section 2.3 “Step 2: Install Windows CDC Driver”**).
2. Reconnect the board by unplugging and plugging in again the USB connection.

SIGNAL STREAMING STOPS

Signal stream in Aurea GUI stops when there is no approach towards the sensing area. This behavior is intended. When using the Aurea GUI, the Wake-up on Approach feature is automatically enabled.

Possible Solutions:

Disable the Wake-up on Approach feature in the Real-Time Control bar of Aurea by unchecking the **Approach Detection/Power Saving** checkbox for continuous signal streaming.

SIGNAL MATCHING PARAMETERS MISMATCHED BY USER

Signal matching parameters have been mismatched and accidentally stored into the Flash.

Possible Solutions:

1. Perform “Autoparameterization” in the **Aurea Setup** tab. Make sure there is no hand approach towards the electrodes during autoparamterization process.
2. Restore the default Signal Matching parameters by re-flashing the original MGC3130 GestIC[®] library file refer to the “MGC3130 – Aurea Graphical User Interface User’s Guide (DS41681).”

NOTES:

Appendix A. Schematics

A.1 INTRODUCTION

This appendix contains the MGC3130 Sabrewing Evaluation Board schematic and Bill of Material.

A.2 BILL OF MATERIAL

TABLE A-1: SABREWING SINGLE-ZONE EVALUATION BOARD BILL OF MATERIAL

Qty.	Description	Name
1	Connector, Mini USB 5-Pin Type B, SMD	BU1
2	Capacitor, 100nF, 10%, X7R, SMD 0402	C1, C2
1	Capacitor, 220nF, 10%, X5R, SMD 0402	C3
2	Capacitor, 1 μ F, 10%, X5R, 10V, SMD 0402	C4, C5
1	Capacitor, 4.7 μ F, 20%, X5R, 6.3V, SMD 0402	C6
1	Capacitor, 10 μ F, 20%, X5R, 6.3V, SMD 0603	C7
2	Capacitor, 18pF, 5%, NP0, 50V, SMD 0402	C9, C10
9	LED, 571nm green clear, 0603 SMD	D2, D4, D5, D6, D7, D8, D9, D10, D11
1	Diode, Zener, 500mW, 3.8V, SMD	D3
1	IC, MGC3130 3D Tracking and Gesture Controller, 28-Pin QFN	IC1
1	IC, MCP1801T LDO, Voltage Regulator, 2.3V, 150 mA, 5-Pin SOT-23	IC2
1	IC, PIC18F14K50 USB Flash Microcontroller, 20-Pin SSOP	IC3
9	Resistor, 1k Ω , 1%, 1/16W, SMD 0402	R1, R2, R3, R4, R5, R8, R9, R12, R14
2	Resistor, 1.8k Ω , 1%, 1/16W, SMD 0402	R6, R7
3	Resistor, 10k Ω , 1%, 1/16W, SMD 0402	R11, R13, R21
1	Resistor, 150k Ω , 1%, 1/16W, SMD 0402	R16
6	Resistor, 0 Ω , 1%, 1/16W, SMD 0603	R22, R23, R24, R32, R33, R35

MGC3130 – Sabrewing Single-Zone Evaluation Kit User’s Guide

TABLE A-1: SABREWING SINGLE-ZONE EVALUATION BOARD BILL OF MATERIAL

5	Resistor, 1kΩ, 1%, 1/16W, SMD 0603	R25, R26, R27, R28, R29
1	Switch, Push Button, 0,05A@12V, 6mm x 6 mm	SW1
1	Crystal, 12 MHz, 18pF, SMD	XTAL1
1	Acrylic Glass, 180 x 116.5 x 2 mm, Drill 3.2 mm	
4	Push-in Rivets, 3.0 x 1.0-4.0, Nylon-66, natural	

A.3 BOARD SCHEMATIC AND LAYOUT

FIGURE A-1: SABREWING SCHEMATIC PART I: MGC3130 REFERENCE CIRCUITRY

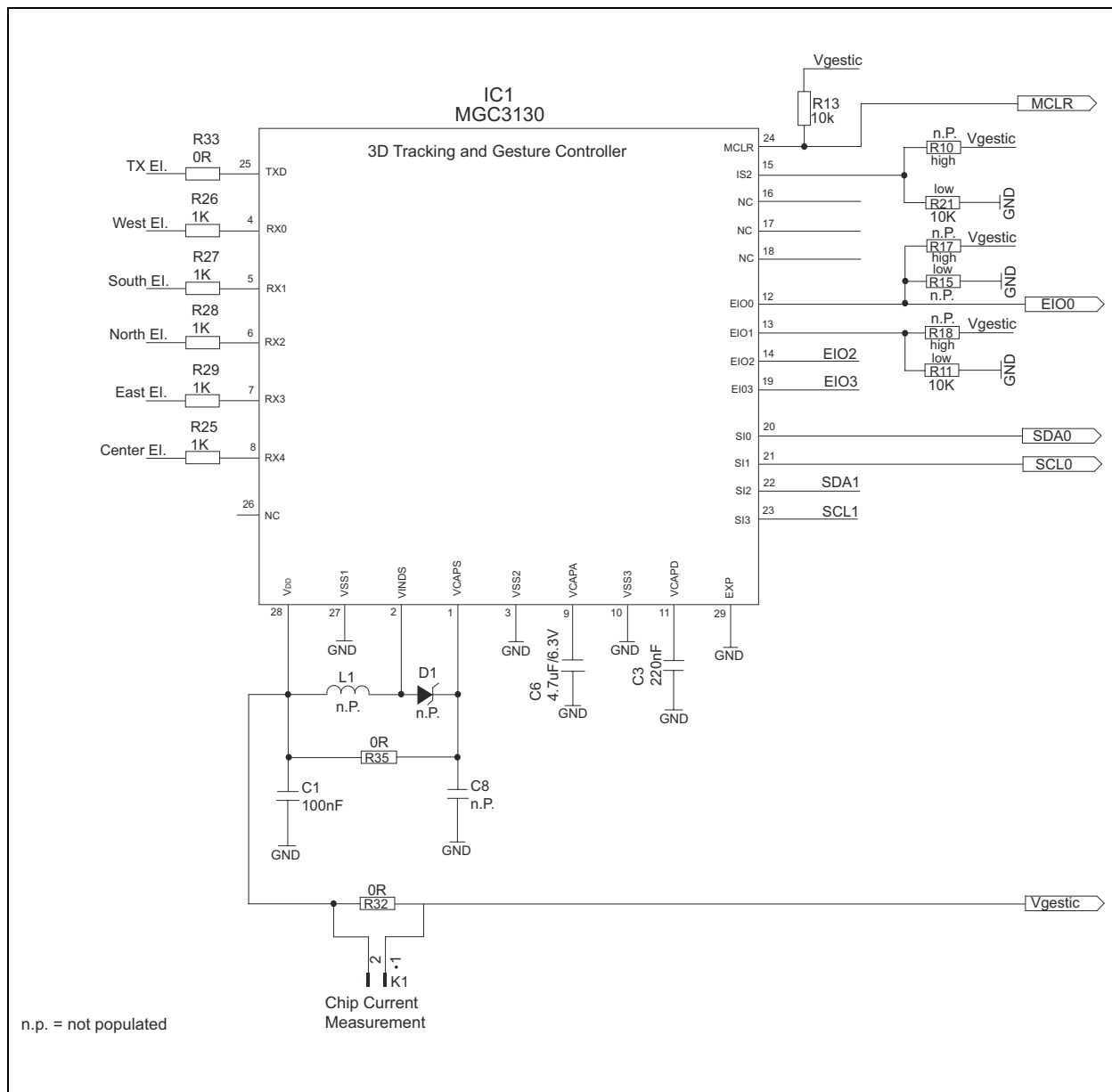

FIGURE A-2: SABREWING SCHEMATIC PART II: I²C TO USB BRIDGE

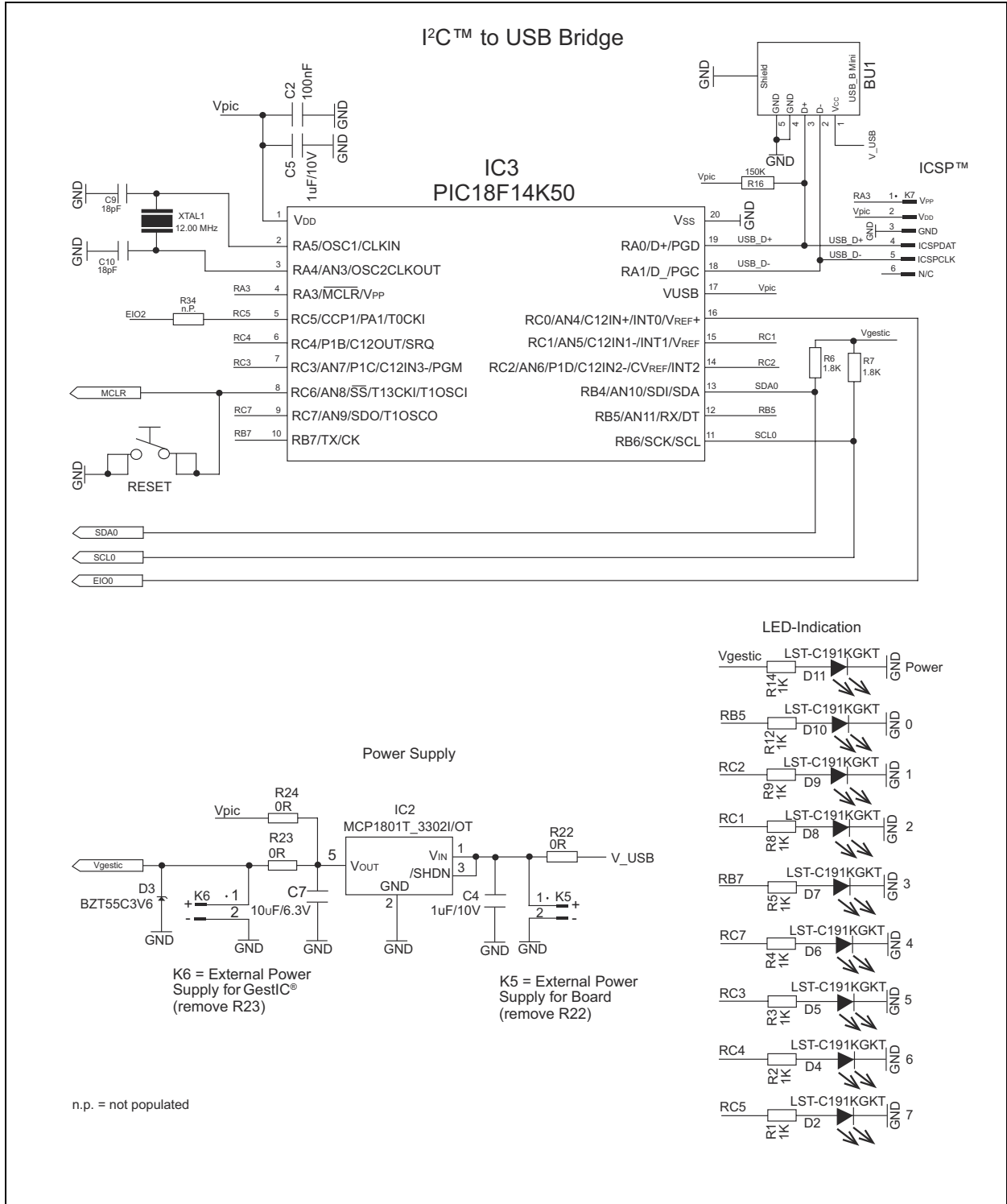
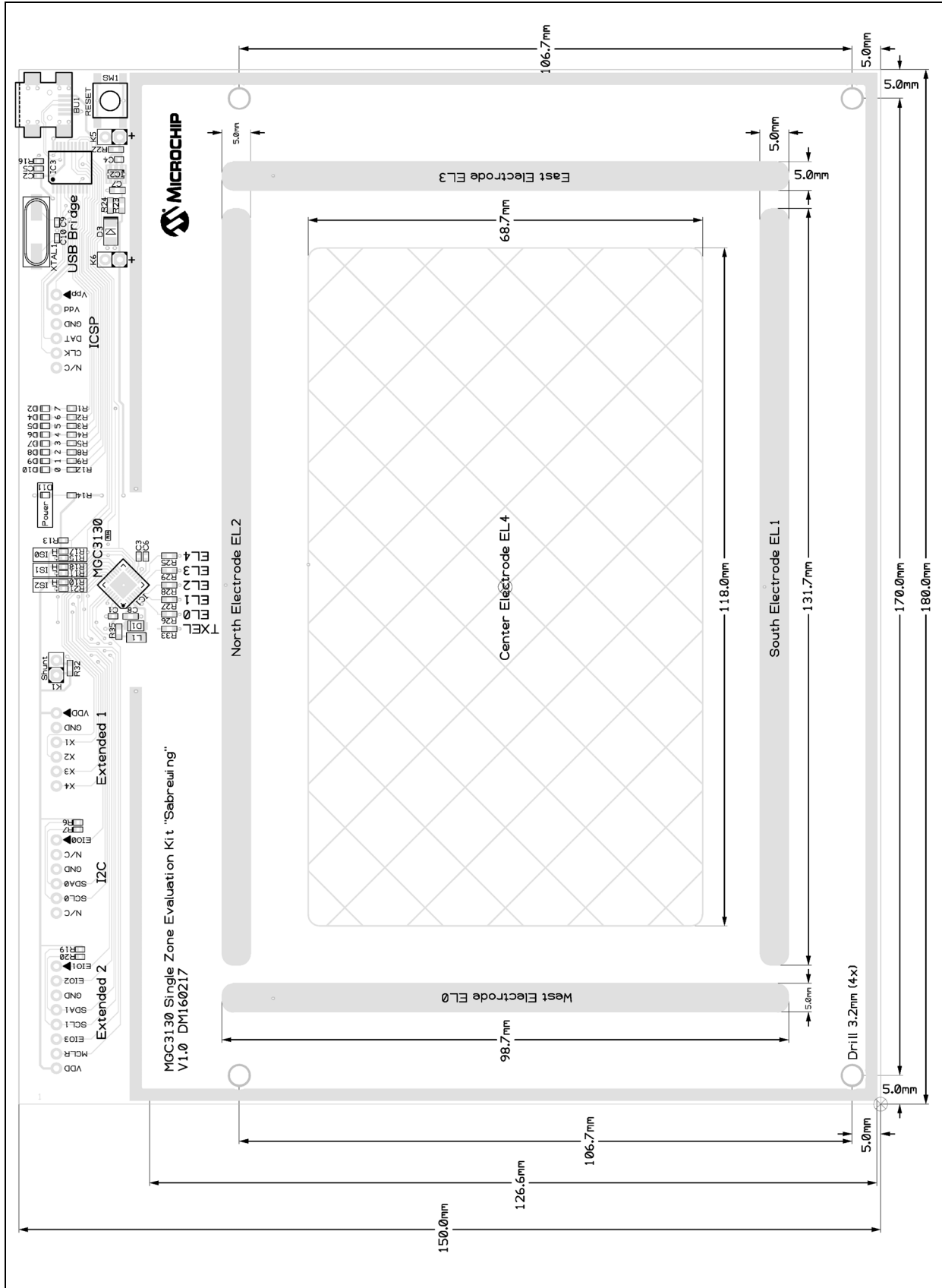

FIGURE A-3: SABREWING SINGLE-ZONE EVALUATION BOARD LAYOUT TOP LAYER



Appendix B. Sensitivity Profile and Capacities

B.1 INTRODUCTION

This appendix contains the sensitivity profile and the electrode capacities of the MGC3130 Sabrewing Evaluation Board.

B.2 SENSITIVITY PROFILES

FIGURE B-1: SENSITIVITY PROFILE FROM WEST TO EAST

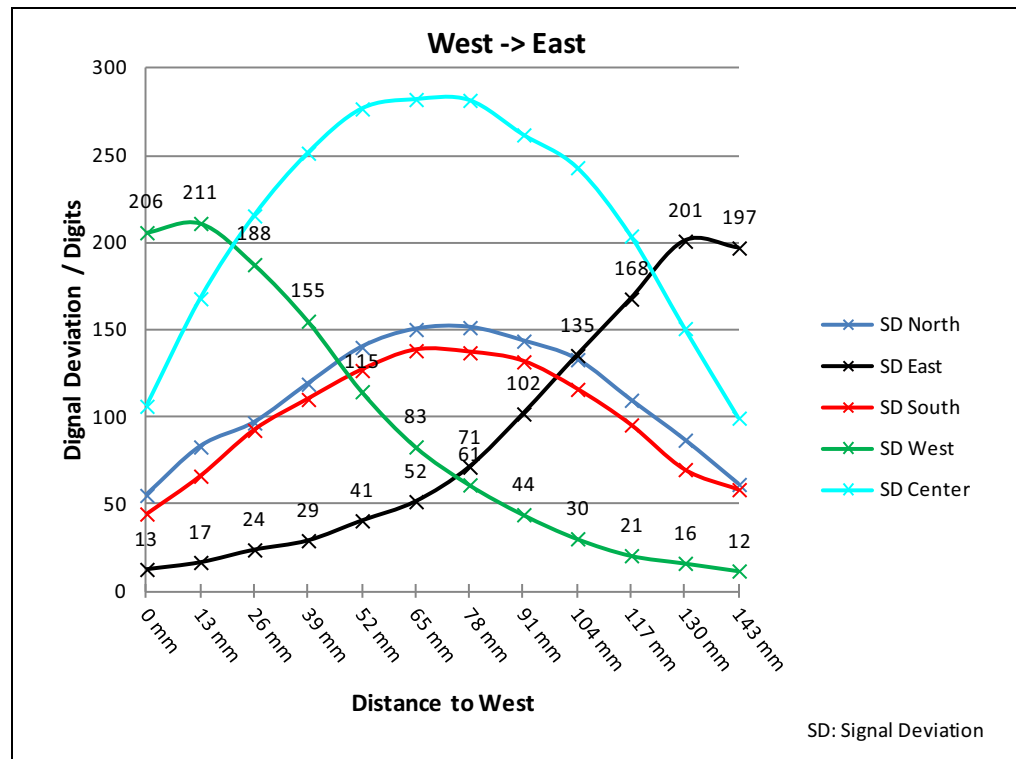
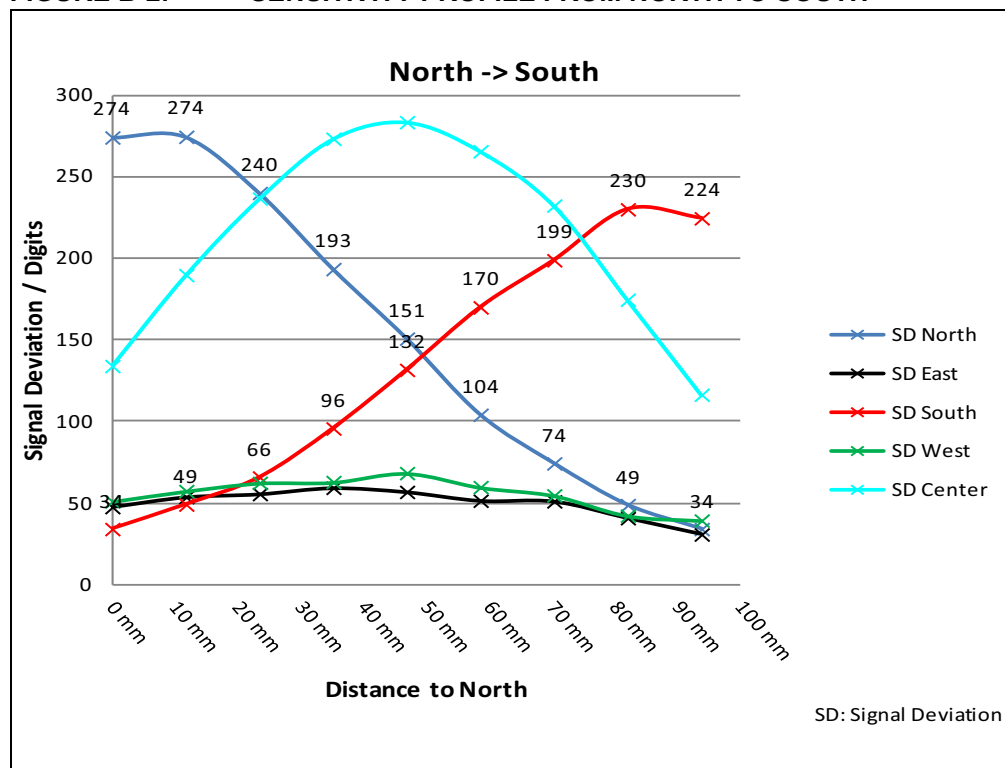

FIGURE B-2: SENSITIVITY PROFILE FROM NORTH TO SOUTH



B.3 ELECTRODE CAPACITIES

TABLE B-1: CAPACITIES

Channel	C_{RxGND}	C_{RxTx}
West	19 pF	24 pF
North	18 pF	25 pF
East	18 pF	26 pF
South	20 pF	32 pF
Center	12 pF	113 pF

$C_{TxGND} = 885 \text{ pF}$

Appendix C. Driver Installation Manual

The following steps show how to install the Microchip CDC driver through the device manager of Windows 7.

1. Open Device Manager

While the Sabrewing Evaluation Board is connected to your PC press **Start**, right-click on **Computers** and select **Manage**. This will bring up the Computer Management window shown in Figure C-1. On the left sidebar, select **Device Manager**.

FIGURE C-1: COMPUTER MANAGEMENT

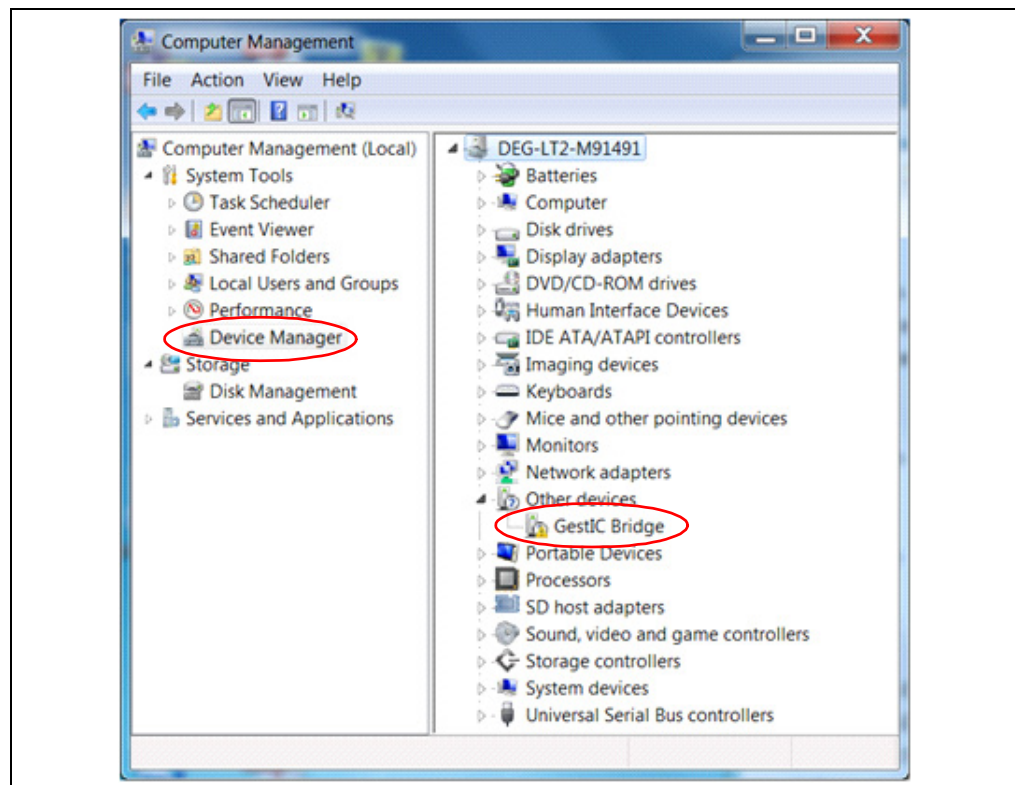

2. Select Device

Right Click on **GestIC Bridge** and select **Update Driver Software**.

3. Select Search Method

The window shown in Figure C-2 will open. Choose **Browse my Computer for driver software**.

FIGURE C-2: UPDATE DRIVER SOFTWARE

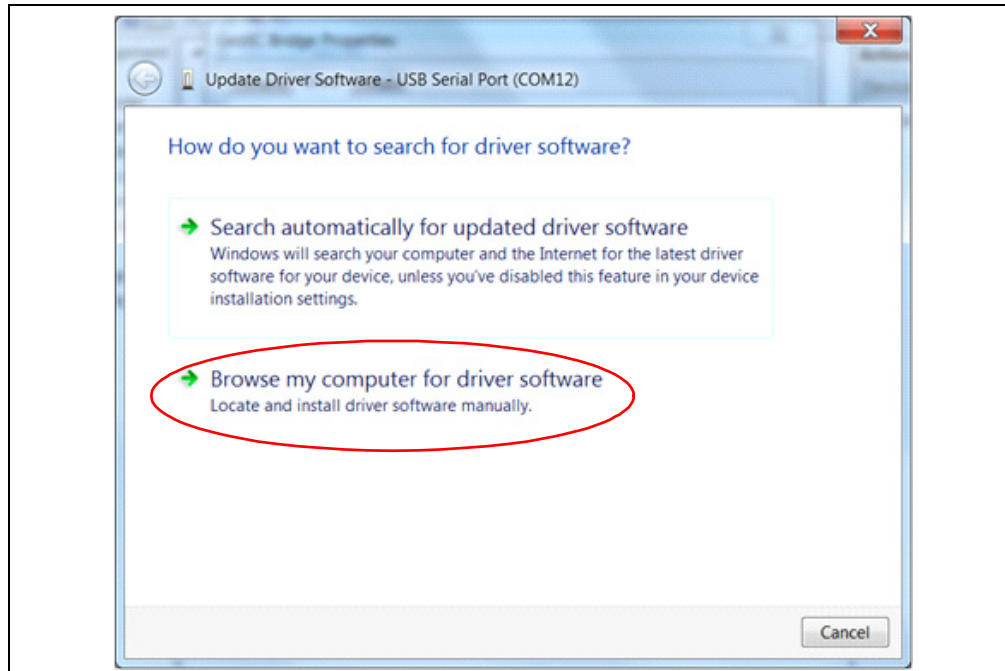

4. Locate Driver

Click **Browse** and navigate to the driver files on your local drive (Figure C-3). Press **Next** and the driver will be installed.

FIGURE C-3: BROWSE FOR DRIVER SOFTWARE

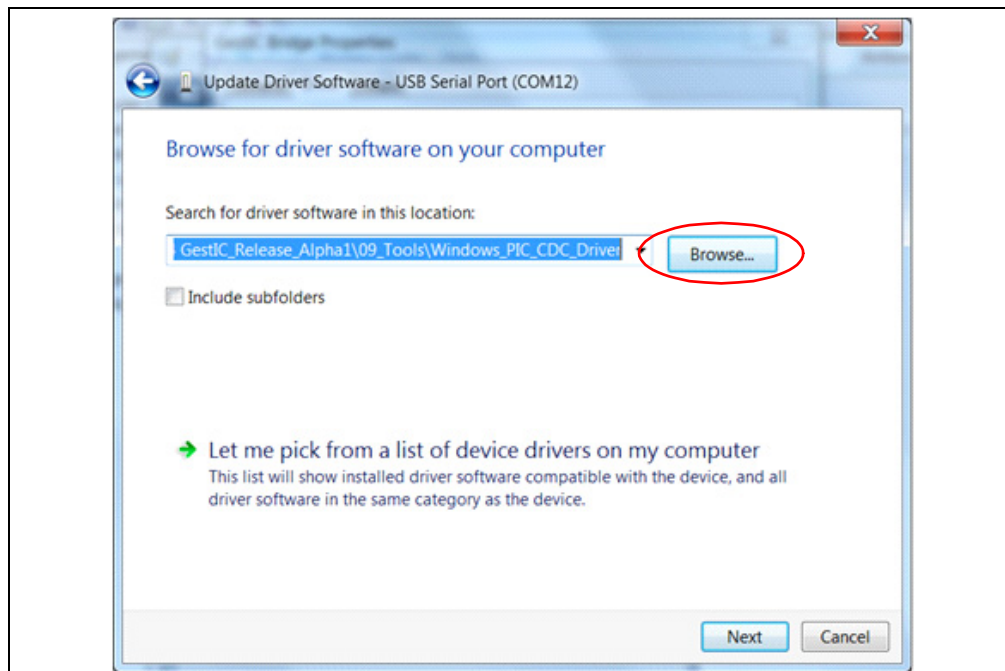

5. Verify Communication

The driver is properly installed and the communication between the PC and the Sabrewing Evaluation Board is successfully established when LED 1 and LED 2 blink alternately.



MGC3130 – SABREWING SINGLE-ZONE EVALUATION KIT USER’S GUIDE

Appendix D. Glossary

Term	Definition
AFE	Analog front end
Application Host	PC or embedded controller which controls the MGC3130
Aurea	MGC3130 PC control software with graphical user interface
Colibri Suite	Embedded DSP suite within the GestIC [®] Library
Deep Sleep	MGC3130 Power-saving mode
E-field	Electrical field
Frame Electrodes	Rectangular set of 4 electrodes for E-field sensing
GestIC[®] Technology	Microchip’s patented technology providing 3D free-space gesture recognition utilizing the principles of electrical near-field sensing
GestIC[®] Library	Includes the implementation of MGC3130 features and is delivered as a binary file preprogrammed on the MGC3130
Gesture Recognition	Microchip’s stochastic HMM classifier to automatically detect and classify hand movement patterns
Gesture Set	A set of provided hand movement patterns
Hand Brick	Copper coated test block (7 cm x 4 cm x 4 cm)
HMM	Hidden Markov Model
MGC3130	Single Zone 3D Gesture Sensing Controller
Position Tracking	GestIC technology feature
Sabrewing	MGC3130 evaluation board
Self Wake-Up	MGC3130 Power-saving mode
Sensing Zone	The three dimensional area near the electrodes in which tracking/gesture recognition can be performed
Signal Deviation	Term for the delta of the sensor signal on approach of the hand versus non-approach
Spacer Brick	Spacer between the sensor layer and hand brick (styrofoam block 4 cm x 4 cm x h with h= 1 / 2 / 3 / 5 / 8 / 12 cm)
SPU	Signal Processing Unit
Approach Detection	GestIC technology feature: Power-Saving mode of the MGC3130 with approach detection



MICROCHIP

Worldwide Sales and Service

AMERICAS

Corporate Office
2355 West Chandler Blvd.
Chandler, AZ 85224-6199
Tel: 480-792-7200
Fax: 480-792-7277
Technical Support:
<http://www.microchip.com/support>
Web Address:
www.microchip.com

Atlanta
Duluth, GA
Tel: 678-957-9614
Fax: 678-957-1455

Boston
Westborough, MA
Tel: 774-760-0087
Fax: 774-760-0088

Chicago
Itasca, IL
Tel: 630-285-0071
Fax: 630-285-0075

Cleveland
Independence, OH
Tel: 216-447-0464
Fax: 216-447-0643

Dallas
Addison, TX
Tel: 972-818-7423
Fax: 972-818-2924

Detroit
Farmington Hills, MI
Tel: 248-538-2250
Fax: 248-538-2260

Indianapolis
Noblesville, IN
Tel: 317-773-8323
Fax: 317-773-5453

Los Angeles
Mission Viejo, CA
Tel: 949-462-9523
Fax: 949-462-9608

Santa Clara
Santa Clara, CA
Tel: 408-961-6444
Fax: 408-961-6445

Toronto
Mississauga, Ontario,
Canada
Tel: 905-673-0699
Fax: 905-673-6509

ASIA/PACIFIC

Asia Pacific Office
Suites 3707-14, 37th Floor
Tower 6, The Gateway
Harbour City, Kowloon
Hong Kong
Tel: 852-2401-1200
Fax: 852-2401-3431

Australia - Sydney
Tel: 61-2-9868-6733
Fax: 61-2-9868-6755

China - Beijing
Tel: 86-10-8569-7000
Fax: 86-10-8528-2104

China - Chengdu
Tel: 86-28-8665-5511
Fax: 86-28-8665-7889

China - Chongqing
Tel: 86-23-8980-9588
Fax: 86-23-8980-9500

China - Hangzhou
Tel: 86-571-2819-3187
Fax: 86-571-2819-3189

China - Hong Kong SAR
Tel: 852-2943-5100
Fax: 852-2401-3431

China - Nanjing
Tel: 86-25-8473-2460
Fax: 86-25-8473-2470

China - Qingdao
Tel: 86-532-8502-7355
Fax: 86-532-8502-7205

China - Shanghai
Tel: 86-21-5407-5533
Fax: 86-21-5407-5066

China - Shenyang
Tel: 86-24-2334-2829
Fax: 86-24-2334-2393

China - Shenzhen
Tel: 86-755-8864-2200
Fax: 86-755-8203-1760

China - Wuhan
Tel: 86-27-5980-5300
Fax: 86-27-5980-5118

China - Xian
Tel: 86-29-8833-7252
Fax: 86-29-8833-7256

China - Xiamen
Tel: 86-592-2388138
Fax: 86-592-2388130

China - Zhuhai
Tel: 86-756-3210040
Fax: 86-756-3210049

ASIA/PACIFIC

India - Bangalore
Tel: 91-80-3090-4444
Fax: 91-80-3090-4123

India - New Delhi
Tel: 91-11-4160-8631
Fax: 91-11-4160-8632

India - Pune
Tel: 91-20-2566-1512
Fax: 91-20-2566-1513

Japan - Osaka
Tel: 81-6-6152-7160
Fax: 81-6-6152-9310

Japan - Tokyo
Tel: 81-3-6880-3770
Fax: 81-3-6880-3771

Korea - Daegu
Tel: 82-53-744-4301
Fax: 82-53-744-4302

Korea - Seoul
Tel: 82-2-554-7200
Fax: 82-2-558-5932 or
82-2-558-5934

Malaysia - Kuala Lumpur
Tel: 60-3-6201-9857
Fax: 60-3-6201-9859

Malaysia - Penang
Tel: 60-4-227-8870
Fax: 60-4-227-4068

Philippines - Manila
Tel: 63-2-634-9065
Fax: 63-2-634-9069

Singapore
Tel: 65-6334-8870
Fax: 65-6334-8850

Taiwan - Hsin Chu
Tel: 886-3-5778-366
Fax: 886-3-5770-955

Taiwan - Kaohsiung
Tel: 886-7-213-7828
Fax: 886-7-330-9305

Taiwan - Taipei
Tel: 886-2-2508-8600
Fax: 886-2-2508-0102

Thailand - Bangkok
Tel: 66-2-694-1351
Fax: 66-2-694-1350

EUROPE

Austria - Wels
Tel: 43-7242-2244-39
Fax: 43-7242-2244-393

Denmark - Copenhagen
Tel: 45-4450-2828
Fax: 45-4485-2829

France - Paris
Tel: 33-1-69-53-63-20
Fax: 33-1-69-30-90-79

Germany - Munich
Tel: 49-89-627-144-0
Fax: 49-89-627-144-44

Italy - Milan
Tel: 39-0331-742611
Fax: 39-0331-466781

Netherlands - Drunen
Tel: 31-416-690399
Fax: 31-416-690340

Spain - Madrid
Tel: 34-91-708-08-90
Fax: 34-91-708-08-91

UK - Wokingham
Tel: 44-118-921-5869
Fax: 44-118-921-5820

11/29/12